

IS65WV25616ALL IS65WV25616BLL



256K x 16 LOW VOLTAGE, ULTRA LOW POWER CMOS STATIC SRAM

SEPTEMBER 2008

FEATURES

- High-speed access time: 55ns, 70ns
- CMOS low power operation
36 mW (typical) operating
9 μ W (typical) CMOS standby
- TTL compatible interface levels
- Single power supply
1.65V--2.2V V_{DD} (65WV25616ALL)
2.5V--3.6V V_{DD} (65WV25616BLL)
- Fully static operation: no clock or refresh required
- Three state outputs
- Data control for upper and lower bytes
- TEMPERATURE OFFERINGS:
Option A1: -40°C to +85°C
Option A2: -40°C to +105°C
Option A3: -40°C to +125°C
- Lead-free available

DESCRIPTION

The *ISSI* IS65WV25616ALL/IS65WV25616BLL are high-speed, low power, 4M bit SRAMs organized as 256K words by 16 bits. It is fabricated using *ISSI's* high-performance CMOS technology. This highly reliable process coupled with innovative circuit design techniques, yields high-performance and low power consumption devices.

When $\overline{CS1}$ is HIGH (deselected) or when $\overline{CS1}$ is LOW, and both \overline{LB} and \overline{UB} are HIGH, the device assumes a standby mode at which the power dissipation can be reduced down with CMOS input levels.

Easy memory expansion is provided by using Chip Enable and Output Enable inputs. The active LOW Write Enable (\overline{WE}) controls both writing and reading of the memory. A data byte allows Upper Byte (\overline{UB}) and Lower Byte (\overline{LB}) access.

The IS65WV25616BALL/65WV25616BLL are packaged in the JEDEC standard 44-Pin TSOP (TYPE II) and 48-pin mini BGA (6mmx8mm).

FUNCTIONAL BLOCK DIAGRAM

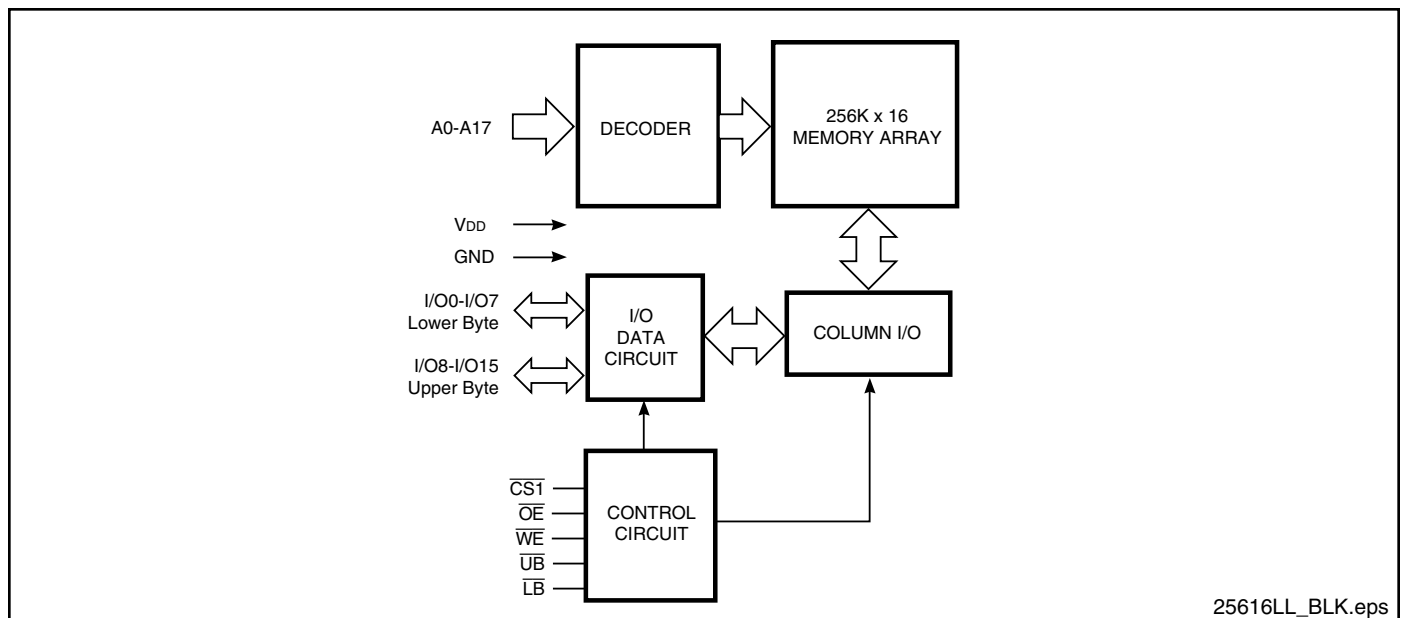

Copyright © 2006 Integrated Silicon Solution, Inc. All rights reserved. ISSI reserves the right to make changes to this specification and its products at any time without notice. ISSI assumes no liability arising out of the application or use of any information, products or services described herein. Customers are advised to obtain the latest version of this device specification before relying on any published information and before placing orders for products.

**44-Pin mini TSOP (Type II)
(Package Code T)**

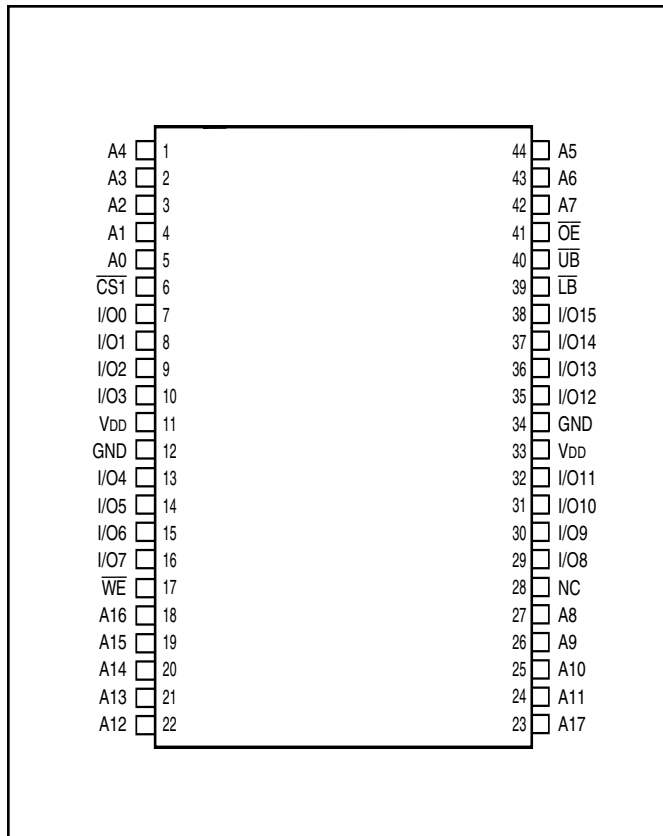

**PIN CONFIGURATIONS
48- ball mini BGA (6mm x 8mm)
(Package Code B)**

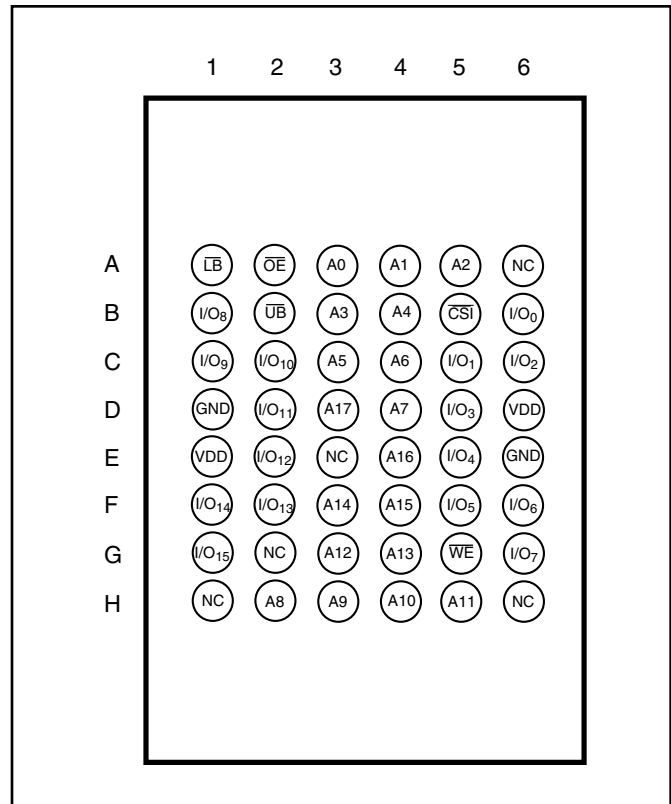

PIN DESCRIPTIONS

A0-A17	Address Inputs
I/O0-I/O15	Data Inputs/Outputs
CS1	Chip Enable Input
OE	Output Enable Input
WE	Write Enable Input
LB	Lower-byte Control (I/O0-I/O7)
UB	Upper-byte Control (I/O8-I/O15)
NC	No Connection
VDD	Power
GND	Ground

TRUTH TABLE

Mode	\overline{WE}	$\overline{CS1}$	\overline{OE}	\overline{LB}	\overline{UB}	I/O PIN		V _{DD} Current
						I/O0-I/O7	I/O8-I/O15	
Not Selected	X	H	X	X	X	High-Z	High-Z	ISB1, ISB2
	X	X	X	X	X	High-Z	High-Z	ISB1, ISB2
	X	X	X	H	H	High-Z	High-Z	ISB1, ISB2
Output Disabled	H	L	H	L	X	High-Z	High-Z	I _{CC}
	H	L	H	X	L	High-Z	High-Z	I _{CC}
Read	H	L	L	L	H	DOUT	High-Z	I _{CC}
	H	L	L	H	L	High-Z	DOUT	
	H	L	L	L	L	DOUT	DOUT	
Write	L	L	X	L	H	DIN	High-Z	I _{CC}
	L	L	X	H	L	High-Z	DIN	
	L	L	X	L	L	DIN	DIN	

ABSOLUTE MAXIMUM RATINGS⁽¹⁾

Symbol	Parameter	Value	Unit
V _{TERM}	Terminal Voltage with Respect to GND	-0.2 to V _{DD} +0.3	V
V _{DD}	V _{DD} Related to GND	-0.2 to V _{DD} +0.3	V
T _{STG}	Storage Temperature	-65 to +150	°C
P _T	Power Dissipation	1.0	W

Note:

1. Stress greater than those listed under ABSOLUTE MAXIMUM RATINGS may cause permanent damage to the device. This is a stress rating only and functional operation of the device at these or any other conditions above those indicated in the operational sections of this specification is not implied. Exposure to absolute maximum rating conditions for extended periods may affect reliability.

OPERATING RANGE (V_{DD})

Range	Ambient Temperature	IS65WV25616ALL	IS65WV25616BLL
A1	-40°C to +85°C	1.65V - 2.2V	2.5V-3.6V
A2	-40°C to +105°C	1.65V - 2.2V	2.5V-3.6V
A3	-40°C to +125°C	1.65V - 2.2V	2.5V-3.6V

DC ELECTRICAL CHARACTERISTICS (Over Operating Range)

Symbol	Parameter	Test Conditions	V _{DD}	Min.	Max.	Unit
V _{OH}	Output HIGH Voltage	I _{OH} = -0.1 mA	1.65-2.2V	1.4	—	V
		I _{OH} = -1 mA	2.5-3.6V	2.2	—	V
V _{OL}	Output LOW Voltage	I _{OL} = 0.1 mA	1.65-2.2V	—	0.2	V
		I _{OL} = 2.1 mA	2.5-3.6V	—	0.4	V
V _{IH}	Input HIGH Voltage		1.65-2.2V	1.4	V _{DD} + 0.2	V
			2.5-3.6V	2.2	V _{DD} + 0.3	V
V _{IL} ⁽¹⁾	Input LOW Voltage		1.65-2.2V	-0.2	0.4	V
			2.5-3.6V	-0.2	0.6	V
I _{LI}	Input Leakage	GND ≤ V _{IN} ≤ V _{DD}		-2	2	μA
I _{LO}	Output Leakage	GND ≤ V _{OUT} ≤ V _{DD} , Outputs Disabled		-2	2	μA

Notes:

1. V_{IL} (min.) = -1.0V for pulse width less than 10 ns.

IS65WV25616ALL, IS65WV25616BLL

IS65WV25616ALL, POWER SUPPLY CHARACTERISTICS⁽¹⁾ (Over Operating Range)

Symbol	Parameter	Test Conditions	Max. 70	Unit
I _{CC}	V _{DD} Dynamic Operating Supply Current	V _{DD} = Max., A1	25	mA
		I _{OUT} = 0 mA, f = f _{MAX} A2, A3	30	
I _{CC1}	Operating Supply Current	V _{DD} = Max., $\overline{CS1} = 0.2V$ A1	10	mA
		$\overline{WE} = V_{DD}-0.2V$ A2, A3 f=1MHZ	15	
I _{SB1}	TTL Standby Current (TTL Inputs)	V _{DD} = Max., A1	0.5	mA
		V _{IN} = V _{IH} or V _{IL} A2, A3 $\overline{CS1} = V_{IH}$, f = 1 MHz	0.6	
OR				
	ULB Control	V _{DD} = Max., V _{IN} = V _{IH} or V _{IL} $\overline{CS1} = V_{IL}$, f = 0, $\overline{UB} = V_{IH}$, $\overline{LB} = V_{IH}$		
I _{SB2}	CMOS Standby Current (CMOS Inputs)	V _{DD} = Max., A1	15	μA
		$\overline{CS1} \geq V_{DD} - 0.2V$, A2 V _{IN} ≥ V _{DD} - 0.2V, or A3 V _{IN} ≤ 0.2V, f = 0	30 50	
OR				
	ULB Control	V _{DD} = Max., $\overline{CS1} = V_{IL}$, V _{IN} ≤ 0.2V, f = 0; $\overline{UB} / \overline{LB} = V_{DD} - 0.2V$		

IS65WV25616BLL, POWER SUPPLY CHARACTERISTICS⁽¹⁾ (Over Operating Range)

Symbol	Parameter	Test Conditions	Max. 55	Max. 70	Unit
I _{CC}	V _{DD} Dynamic Operating Supply Current	V _{DD} = Max., A1	40	—	mA
		I _{OUT} = 0 mA, f = f _{MAX} A2, A3	—	40	
I _{CC1}	Operating Supply Current	V _{DD} = Max., $\overline{CS1} = 0.2V$ A1	15	—	mA
		$\overline{WE} = V_{DD}-0.2V$, A2, A3 f=1MHZ	—	20	
I _{SB1}	TTL Standby Current (TTL Inputs)	V _{DD} = Max., A1	0.45	—	mA
		V _{IN} = V _{IH} or V _{IL} A2, A3 $\overline{CS1} = V_{IH}$, f = 1 MHz	—	0.45	
OR					
	ULB Control	V _{DD} = Max., V _{IN} = V _{IH} or V _{IL} $\overline{CS1} = V_{IL}$, f = 0, $\overline{UB} = V_{IH}$, $\overline{LB} = V_{IH}$			
I _{SB2}	CMOS Standby Current (CMOS Inputs)	V _{DD} = Max., A1	20	—	μA
		$\overline{CS1} \geq V_{DD} - 0.2V$, A2 V _{IN} ≥ V _{DD} - 0.2V, or A3 V _{IN} ≤ 0.2V, f = 0	— —	55 90	
OR					
	ULB Control	V _{DD} = Max., $\overline{CS1} = V_{IL}$, V _{IN} ≤ 0.2V, f = 0; $\overline{UB} / \overline{LB} = V_{DD} - 0.2V$			

CAPACITANCE⁽¹⁾

Symbol	Parameter	Conditions	Max.	Unit
C _{IN}	Input Capacitance	V _{IN} = 0V	8	pF
C _{OUT}	Input/Output Capacitance	V _{OUT} = 0V	10	pF

Note:

1. Tested initially and after any design or process changes that may affect these parameters.

AC TEST CONDITIONS

Parameter	IS65WV25616ALL (Unit)	IS65WV25616BLL (Unit)
Input Pulse Level	0.4V to V _{DD} -0.2V	0.4V to V _{DD} -0.3V
Input Rise and Fall Times	5 ns	5ns
Input and Output Timing and Reference Level	V _{REF}	V _{REF}
Output Load	See Figures 1 and 2	See Figures 1 and 2

	IS65WV25616ALL 1.65V-2.2V	IS65WV25616BLL 2.5V - 3.6V
R1(Ω)	3070	3070
R2(Ω)	3150	3150
V _{REF}	0.9V	1.5V
V _{TM}	1.8V	2.8V

AC TEST LOADS

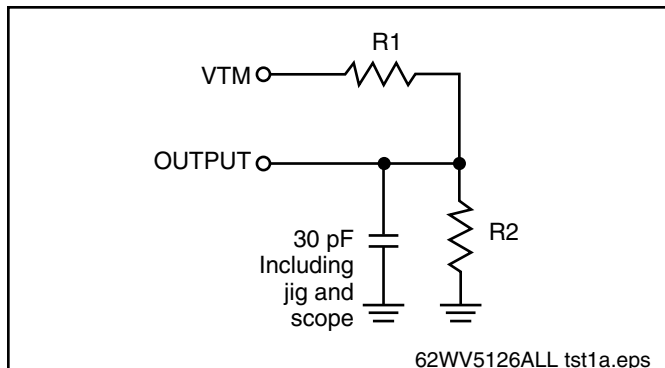

Figure 1

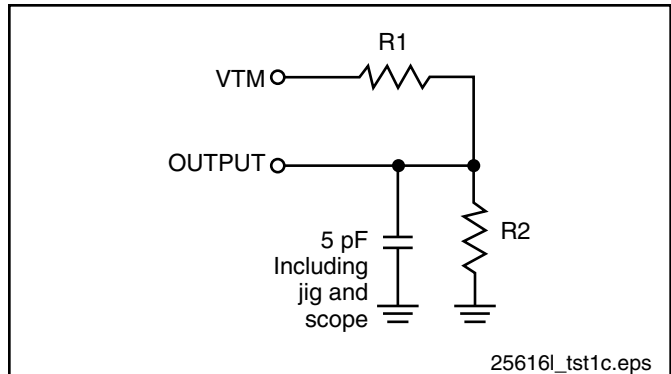

Figure 2

READ CYCLE SWITCHING CHARACTERISTICS⁽¹⁾ (Over Operating Range)

Symbol	Parameter	55 ns		70 ns		Unit
		Min.	Max.	Min.	Max.	
t _{RC}	Read Cycle Time	55	—	70	—	ns
t _{AA}	Address Access Time	—	55	—	70	ns
t _{OHA}	Output Hold Time	10	—	10	—	ns
t _{ACS1}	CS1 Access Time	—	55	—	70	ns
t _{DOE}	OE Access Time	—	25	—	35	ns
t _{HZOE⁽²⁾}	OE to High-Z Output	—	20	—	25	ns
t _{LZOE⁽²⁾}	OE to Low-Z Output	5	—	5	—	ns
t _{HZCS1}	CS1 to High-Z Output	0	20	0	25	ns
t _{LZCS1}	CS1 to Low-Z Output	10	—	10	—	ns
t _{BA}	LB, UB Access Time	—	55	—	70	ns
t _{HZB}	LB, UB to High-Z Output	0	20	0	25	ns
t _{LZB}	LB, UB to Low-Z Output	0	—	0	—	ns

Notes:

1. Test conditions assume signal transition times of 5 ns or less, timing reference levels of 0.9V, input pulse levels of 0.4 to 1.4V and output loading specified in Figure 1.
2. Tested with the load in Figure 2. Transition is measured ±500 mV from steady-state voltage. Not 100% tested.

AC WAVEFORMS

READ CYCLE NO. 1^(1,2) (Address Controlled) ($\overline{CS1} = \overline{OE} = V_{IL}$, $\overline{WE} = V_{IH}$, \overline{UB} or $\overline{LB} = V_{IL}$)

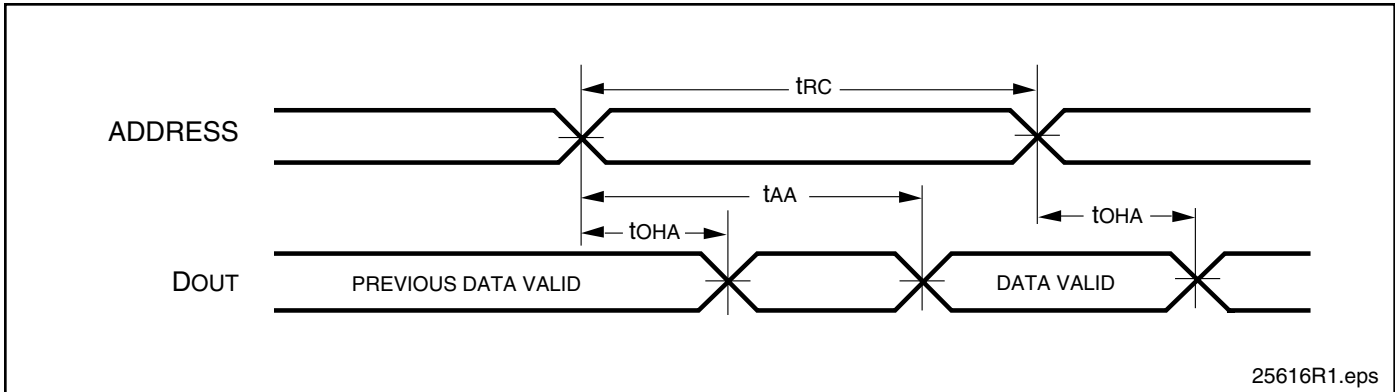

READ CYCLE NO. 2^(1,3) ($\overline{CS1}$, \overline{OE} , AND $\overline{UB}/\overline{LB}$ Controlled)

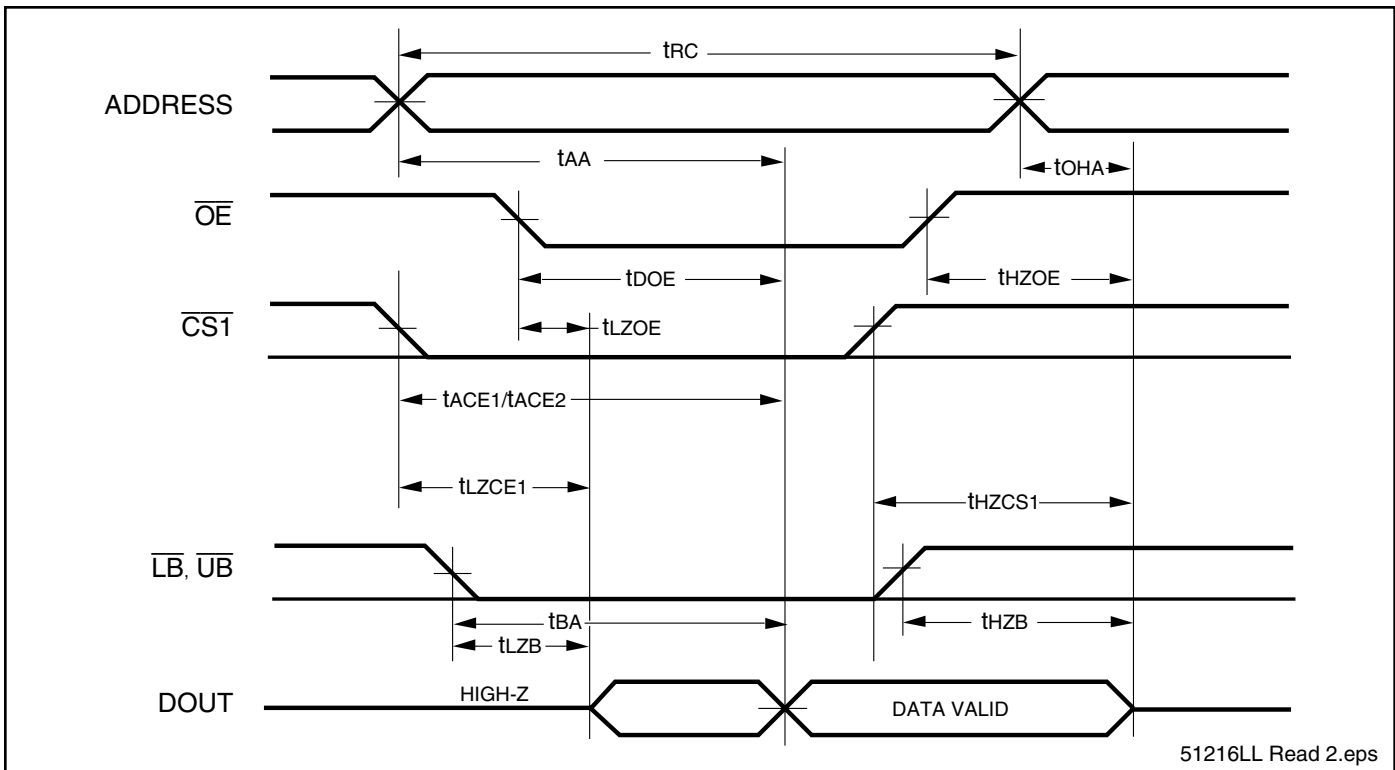

Notes:

1. \overline{WE} is HIGH for a Read Cycle.
2. The device is continuously selected. \overline{OE} , $\overline{CS1}$, \overline{UB} , or $\overline{LB} = V_{IL}$. $\overline{WE} = V_{IH}$.
3. Address is valid prior to or coincident with $\overline{CS1}$ LOW transition.

WRITE CYCLE SWITCHING CHARACTERISTICS^(1,2) (Over Operating Range)

Symbol	Parameter	55 ns		70 ns		Unit
		Min.	Max.	Min.	Max.	
t _{wc}	Write Cycle Time	55	—	70	—	ns
t _{sCS1}	CS1 to Write End	45	—	60	—	ns
t _{AW}	Address Setup Time to Write End	45	—	60	—	ns
t _{HA}	Address Hold from Write End	0	—	0	—	ns
t _{SA}	Address Setup Time	0	—	0	—	ns
t _{PWB}	LB, UB Valid to End of Write	45	—	60	—	ns
t _{PWE}	WE Pulse Width	40	—	50	—	ns
t _{SD}	Data Setup to Write End	25	—	30	—	ns
t _{HD}	Data Hold from Write End	0	—	0	—	ns
t _{HZWE} ⁽³⁾	WE LOW to High-Z Output	—	20	—	20	ns
t _{LZWE} ⁽³⁾	WE HIGH to Low-Z Output	5	—	5	—	ns

Notes:

1. Test conditions assume signal transition times of 5 ns or less, timing reference levels of 0.9V, input pulse levels of 0.4V to 1.4V and output loading specified in Figure 1.
2. The internal write time is defined by the overlap of $\overline{CS1}$ LOW and \overline{UB} or \overline{LB} , and \overline{WE} LOW. All signals must be in valid states to initiate a Write, but any one can go inactive to terminate the Write. The Data Input Setup and Hold timing are referenced to the rising or falling edge of the signal that terminates the write.
3. Tested with the load in Figure 2. Transition is measured ± 500 mV from steady-state voltage. Not 100% tested.

AC WAVEFORMS

WRITE CYCLE NO. 1^(1,2) ($\overline{CS1}$ Controlled, \overline{OE} = HIGH or LOW)

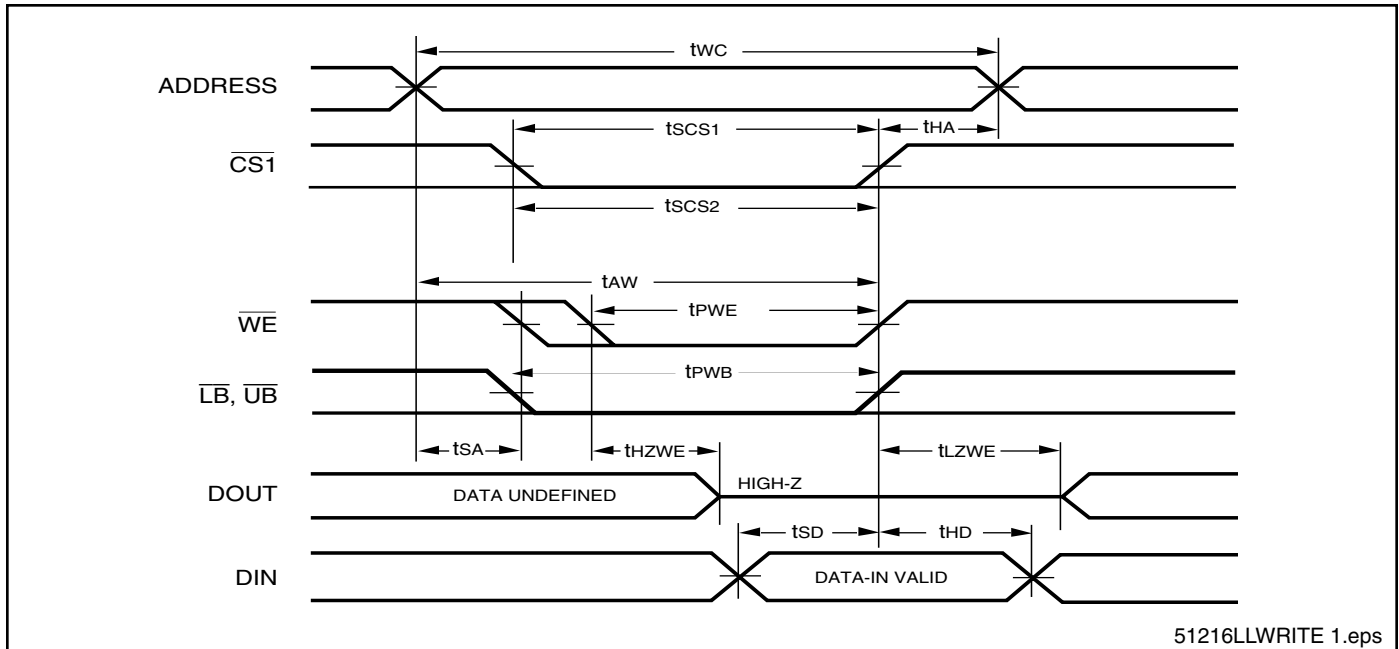

Notes:

1. WRITE is an internally generated signal asserted during an overlap of the LOW states on the $\overline{CS1}$, \overline{WE} inputs and at least one of the \overline{LB} and \overline{UB} inputs being in the LOW state.
2. $WRITE = (\overline{CS1}) [(\overline{LB}) = (\overline{UB})] (\overline{WE})$.

WRITE CYCLE NO. 2 (\overline{WE} Controlled: \overline{OE} is HIGH During Write Cycle)

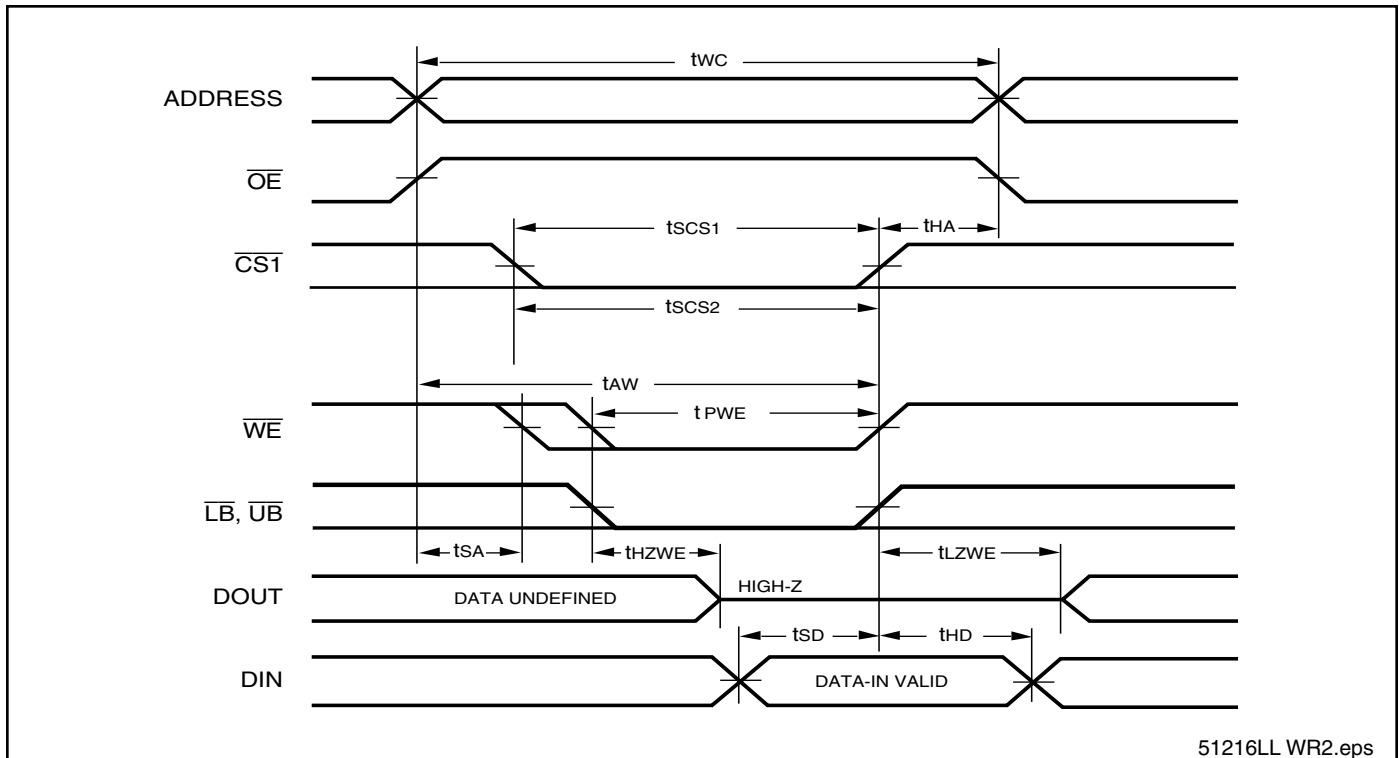

WRITE CYCLE NO. 3 (\overline{WE} Controlled: \overline{OE} is LOW During Write Cycle)

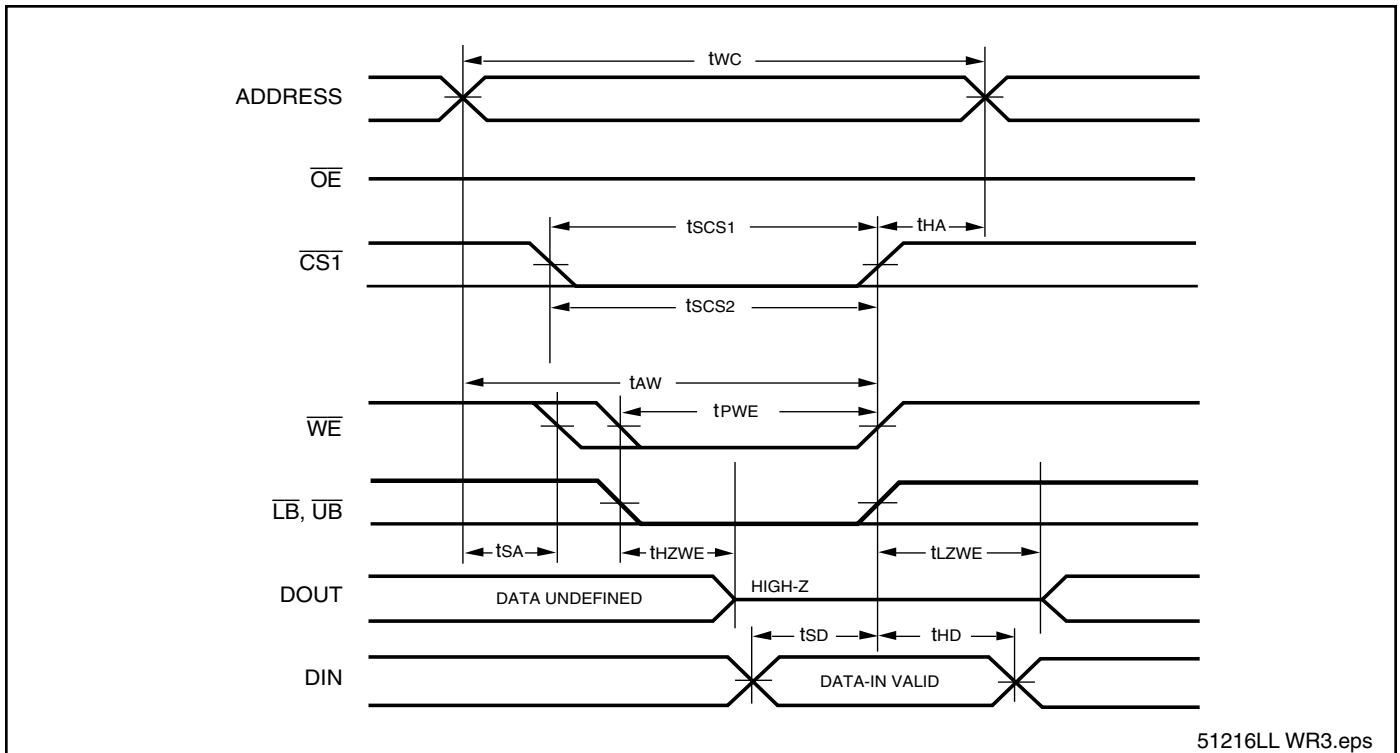

WRITE CYCLE NO. 4 ($\overline{UB}/\overline{LB}$ Controlled)

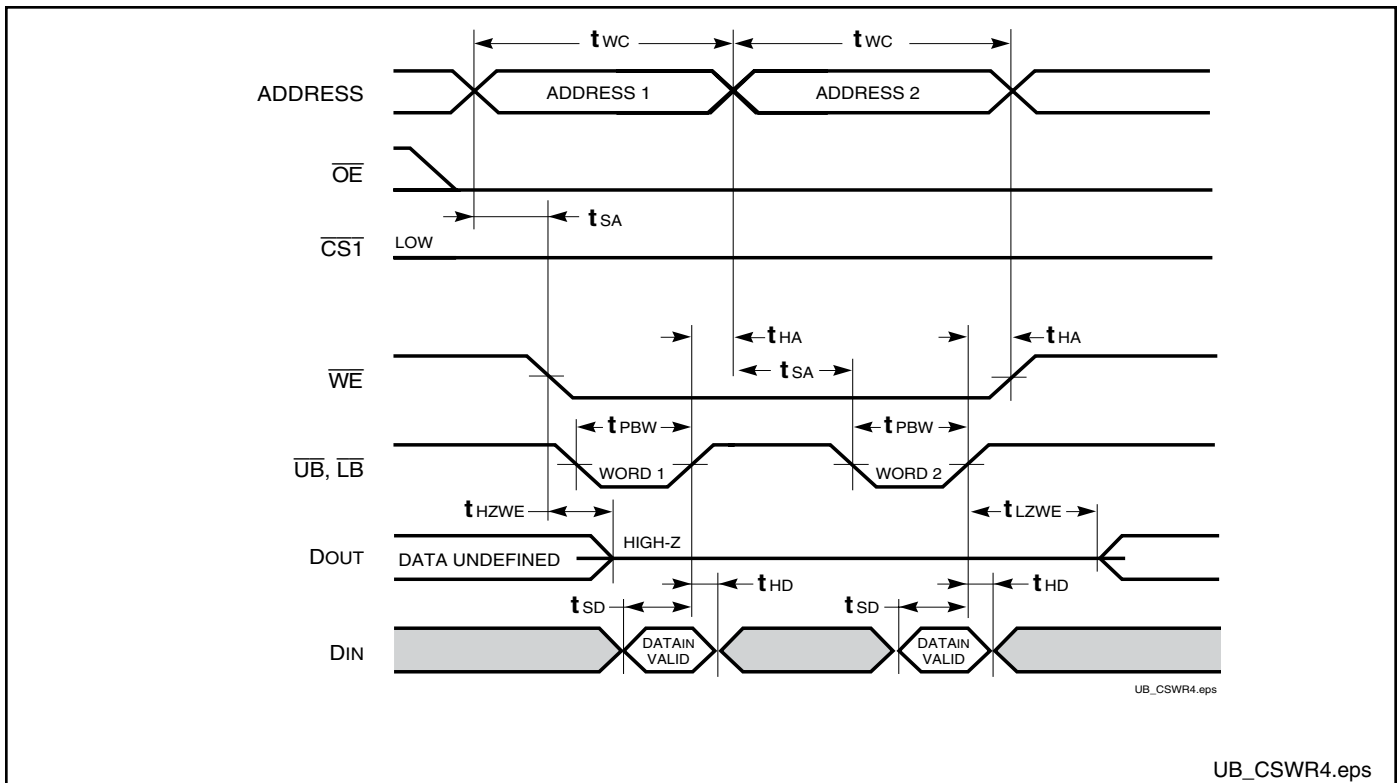

DATA RETENTION SWITCHING CHARACTERISTICS

Symbol	Parameter	Test Condition		Min.	Max.	Unit
V _{DR}	V _{DD} for Data Retention	See Data Retention Waveform		1.2	3.6	V
I _{DR}	Data Retention Current	V _{DD} = 1.2V, CS1 ≥ V _{DD} - 0.2V	A1	—	20	μA
			A2	—	40	μA
			A3	—	60	μA
t _{SDR}	Data Retention Setup Time	See Data Retention Waveform		0	—	ns
t _{RDR}	Recovery Time	See Data Retention Waveform		t _{RC}	—	ns

DATA RETENTION WAVEFORM ($\overline{CS1}$ Controlled)

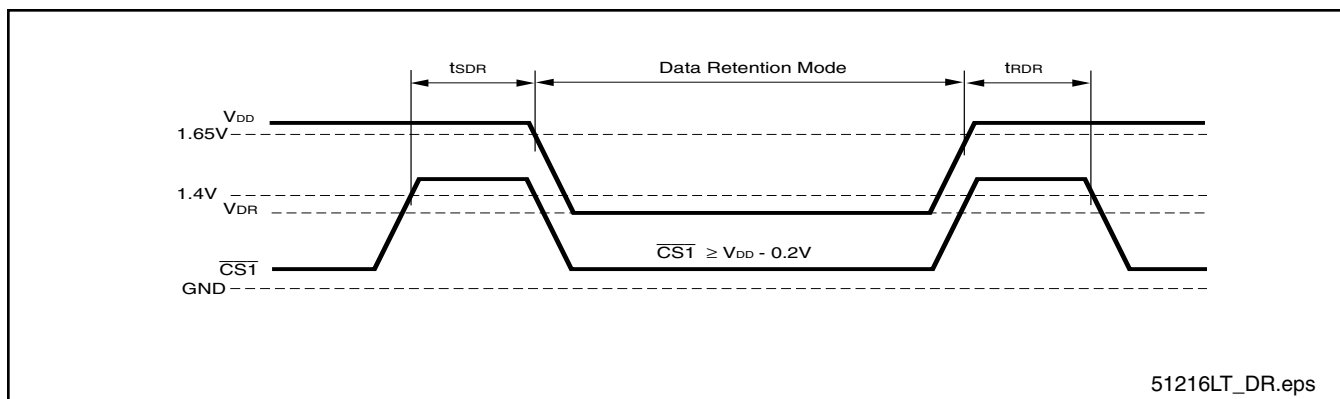

IS65WV25616ALL, IS65WV25616BLL

ORDERING INFORMATION: IS65WV25616ALL (1.65V-2.2V)

Temperature Range (A1): -40°C to +85°C

Speed (ns)	Order Part No.	Package
70	IS65WV25616ALL-70TA1	44-pin TSOP-II

Temperature Range (A2): -40°C to +105°C

Speed (ns)	Order Part No.	Package
70	IS65WV25616ALL-70TA2	44-pin TSOP-II

Temperature Range (A3): -40°C to +125°C

Speed (ns)	Order Part No.	Package
70	IS65WV25616ALL-70TA3	44-pin TSOP-II

ORDERING INFORMATION: IS65WV25616BLL (2.5V-3.6V)

Temperature Range (A1): -40°C to +85°C

Speed (ns)	Order Part No.	Package
55	IS65WV25616BLL-55TA1	44-pin TSOP-II
	IS65WV25616BLL-55TLA1	44-pin TSOP-II, Lead-free
	IS65WV25616BLL-55CTLA1	44-pin TSOP-II, Copper Leadframe, Lead-free
	IS65WV25616BLL-55BA1	48-ball BGA
	IS65WV25616BLL-55BLA1	48-ball BGA, Lead-free

Temperature Range (A2): -40°C to +105°C

Speed (ns)	Order Part No.	Package
70	IS65WV25616BLL-70TA2	44-pin TSOP-II
	IS65WV25616BLL-70BA2	48-ball BGA
	IS65WV25616BLL-70BLA2	48-ball BGA, Lead-free

Temperature Range (A3): -40°C to +125°C

Speed (ns)	Order Part No.	Package
70	IS65WV25616BLL-70TA3	44-pin TSOP-II
	IS65WV25616BLL-70TLA3	44-pin TSOP-II, Lead-free
	IS65WV25616BLL-70BA3	48-ball BGA
	IS65WV25616BLL-70BLA3	48-ball BGA, Lead-free

PACKAGING INFORMATION

Mini Ball Grid Array Package Code: B (48-pin)

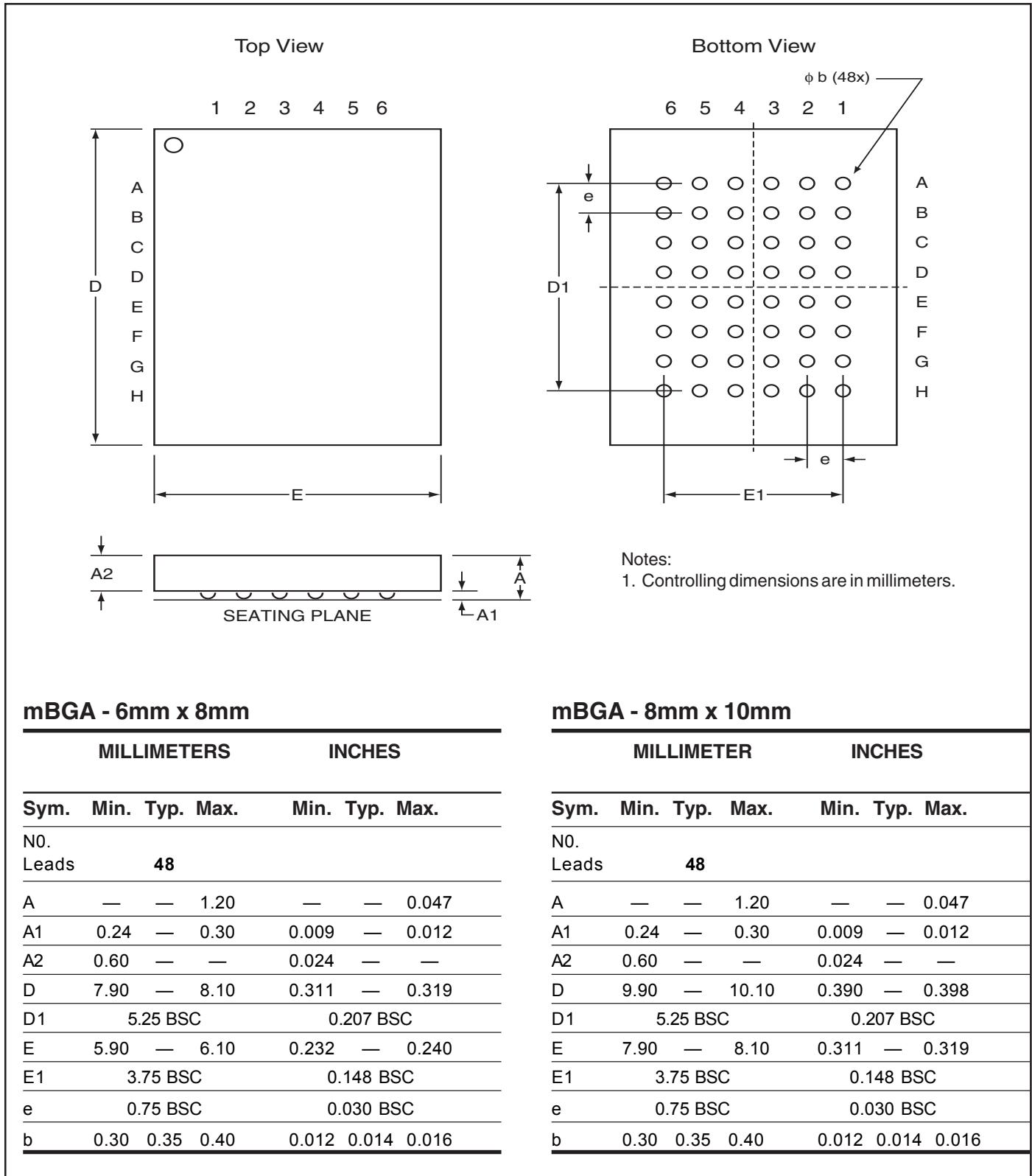

Copyright © 2003 Integrated Silicon Solution, Inc. All rights reserved. ISSI reserves the right to make changes to this specification and its products at any time without notice. ISSI assumes no liability arising out of the application or use of any information, products or services described herein. Customers are advised to obtain the latest version of this device specification before relying on any published information and before placing orders for products.

Integrated Silicon Solution, Inc. — www.issi.com — 1-800-379-4774

Rev. D
01/15/03

PACKAGING INFORMATION

Plastic TSOP
 Package Code: T (Type II)

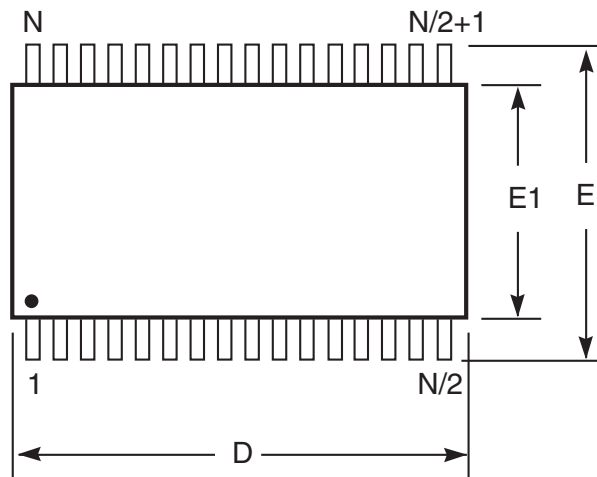

Notes:

1. Controlling dimension: millimeters, unless otherwise specified.
2. BSC = Basic lead spacing between centers.
3. Dimensions D and E1 do not include mold flash protrusions and should be measured from the bottom of the package.
4. Formed leads shall be planar with respect to one another within 0.004 inches at the seating plane.

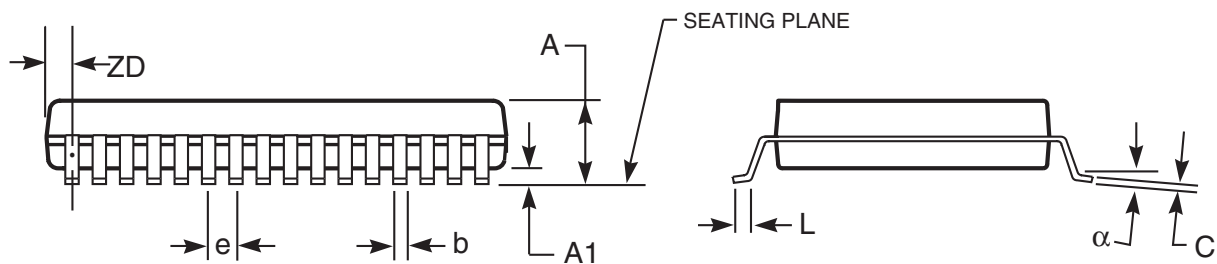

Plastic TSOP (T - Type II)

Symbol	Millimeters		Inches		Millimeters		Inches		Millimeters		Inches	
	Min	Max	Min	Max	Min	Max	Min	Max	Min	Max	Min	Max
Ref. Std.												
No. Leads (N)	32				44				50			
A	—	1.20	—	0.047	—	1.20	—	0.047	—	1.20	—	0.047
A1	0.05	0.15	0.002	0.006	0.05	0.15	0.002	0.006	0.05	0.15	0.002	0.006
b	0.30	0.52	0.012	0.020	0.30	0.45	0.012	0.018	0.30	0.45	0.012	0.018
C	0.12	0.21	0.005	0.008	0.12	0.21	0.005	0.008	0.12	0.21	0.005	0.008
D	20.82	21.08	0.820	0.830	18.31	18.52	0.721	0.729	20.82	21.08	0.820	0.830
E1	10.03	10.29	0.391	0.400	10.03	10.29	0.395	0.405	10.03	10.29	0.395	0.405
E	11.56	11.96	0.451	0.466	11.56	11.96	0.455	0.471	11.56	11.96	0.455	0.471
e	1.27 BSC		0.050 BSC		0.80 BSC		0.032 BSC		0.80 BSC		0.031 BSC	
L	0.40	0.60	0.016	0.024	0.41	0.60	0.016	0.024	0.40	0.60	0.016	0.024
ZD	0.95 REF		0.037 REF		0.81 REF		0.032 REF		0.88 REF		0.035 REF	
α	0°	5°	0°	5°	0°	5°	0°	5°	0°	5°	0°	5°

Copyright © 2003 Integrated Silicon Solution, Inc. All rights reserved. ISSI reserves the right to make changes to this specification and its products at any time without notice. ISSI assumes no liability arising out of the application or use of any information, products or services described herein. Customers are advised to obtain the latest version of this device specification before relying on any published information and before placing orders for products.

Integrated Silicon Solution, Inc. — www.issi.com — 1-800-379-4774

Rev. F
 06/18/03



Компания «ЭлектроПласт» предлагает заключение долгосрочных отношений при поставках импортных электронных компонентов на взаимовыгодных условиях!

Наши преимущества:

- Оперативные поставки широкого спектра электронных компонентов отечественного и импортного производства напрямую от производителей и с крупнейших мировых складов;
- Поставка более 17-ти миллионов наименований электронных компонентов;
- Поставка сложных, дефицитных, либо снятых с производства позиций;
- Оперативные сроки поставки под заказ (от 5 рабочих дней);
- Экспресс доставка в любую точку России;
- Техническая поддержка проекта, помощь в подборе аналогов, поставка прототипов;
- Система менеджмента качества сертифицирована по Международному стандарту ISO 9001;
- Лицензия ФСБ на осуществление работ с использованием сведений, составляющих государственную тайну;
- Поставка специализированных компонентов (Xilinx, Altera, Analog Devices, Intersil, Interpoint, Microsemi, Aeroflex, Peregrine, Syfer, Eurofarad, Texas Instrument, Miteq, Cobham, E2V, MA-COM, Hittite, Mini-Circuits, General Dynamics и др.);

Помимо этого, одним из направлений компании «ЭлектроПласт» является направление «Источники питания». Мы предлагаем Вам помощь Конструкторского отдела:

- Подбор оптимального решения, техническое обоснование при выборе компонента;
- Подбор аналогов;
- Консультации по применению компонента;
- Поставка образцов и прототипов;
- Техническая поддержка проекта;
- Защита от снятия компонента с производства.



Как с нами связаться

Телефон: 8 (812) 309 58 32 (многоканальный)

Факс: 8 (812) 320-02-42

Электронная почта: org@eplast1.ru

Адрес: 198099, г. Санкт-Петербург, ул. Калинина, дом 2, корпус 4, литера А.