

# LOW POWER CONSUMPTION

## conga-TCA3

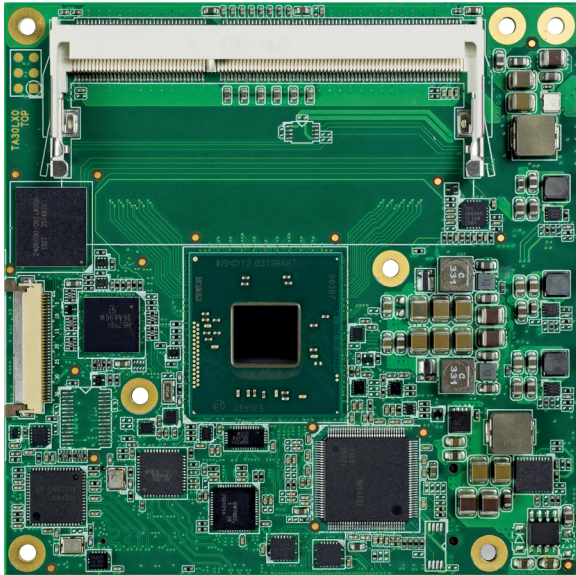

- 3<sup>rd</sup> Gen. Intel® Atom™ processor up to Quad Core
- COM Express Compact Type 6 module
- Temperature range up to -40°C .. +85°C

**COM**  **Express®**

Formfactor	Formfactor COM Express® Compact   (95 x 95 mm)   Type 6 Connector Layout			
CPU	Intel® Atom™ E3845	1.91 GHz Quad Core	L2 Cache 2MB	10W TDP
	Intel® Atom™ E3827	1.75 GHz Dual Core	L2 Cache 1MB	8W TDP
	Intel® Atom™ E3826	1.46 GHz Dual Core	L2 Cache 1MB	7W TDP
	Intel® Atom™ E3825	1.33 GHz Dual Core	L2 Cache 1MB	6W TDP
	Intel® Atom™ E3815	1.46 GHz Single Core	L2 Cache 512kB	5W TDP
	Intel® Celeron® J1900	2.0 GHz Quad Core	L2 Cache 2MB	10W TDP
	Intel® Celeron® N2930	1.83 GHz Quad Core	L2 Cache 2MB	7.5W TDP
	Intel® Celeron® N2807	1.58 GHz Dual Core	L2 Cache 1MB	4.3W TDP
DRAM	2 SO-DIMM sockets for DDR3L memory modules up to 8 GByte with 1333MT/s   Dual channel memory interface for increased graphics performance.			
Chipset	Integrated in SoC			
Ethernet	Intel I210 Gigabit Ethernet			
I/O Interfaces	Up to 5x PCIe x1   8x USB 2.0   1x USB 3.0   2x SATA   LPC   SPI   I <sup>2</sup> C bus (fast mode 400 kHz   multi-master)   SDIO			
Sound	Digital High Definition Audio Interface			
Graphics	Intel® HD Graphics Gen 7   Full hardware acceleration for MPEG2   H.264   DirectX11   OCL 1.1   OGL 3.2   WMV9 and VC1			
LVDS	Dual channel LVDS transmitter   support for flat panels with 2x24 bit data mapping up to a resolution of 1920x1200@60Hz.			
Digital Display Interface (DDI)	Up to 2x DisplayPort 1.1 (max. 2560x1600) or HDMI 1.4a (max. 1920x1200)			
CRT Interface	320 MHz RAMDAC   resolutions up to 2560x1600			
congatec Board Controller	Multi Stage Watchdog   non-volatile User Data Storage   Manufacturing and Board Information   Board Statistics   BIOS Setup Data Backup   I <sup>2</sup> C bus (fast mode, 400 kHz, multi-master)   Power Loss Control			
Embedded BIOS Features	OEM Logo   OEM CMOS Defaults   LCD Control   Display Auto Detection   Backlight Control   Flash Update   based on AMI Aptio UEFI			
Security	Trusted Platform Module (TPM) optional. Hash and RSA algorithms   key lengths up to 2048 bits   real random number generator			
Power Management	ACPI 5.0 with battery support			
Operating Systems	Microsoft® Windows 8   Microsoft® Windows 7   Linux   Microsoft® Windows Embedded Standard Microsoft® Windows 7 Embedded Compact			
Power Consumption	Typ. application: see user's guide for full details   CMOS Battery Backup			
Temperature	Commercial :	Operating: 0 to +60°C	Storage: -20 to +80°C	
	Industrial :	Operating: -40 to +85°C	Storage: -45 to +85°C	
Humidity	Operating: 10 - 90% r. H. non cond. Storage: 5 - 95% r. H. non cond.			
Size	95 x 95 mm (3.74" x 3.74")			

# conga-TCA3 | Block diagram

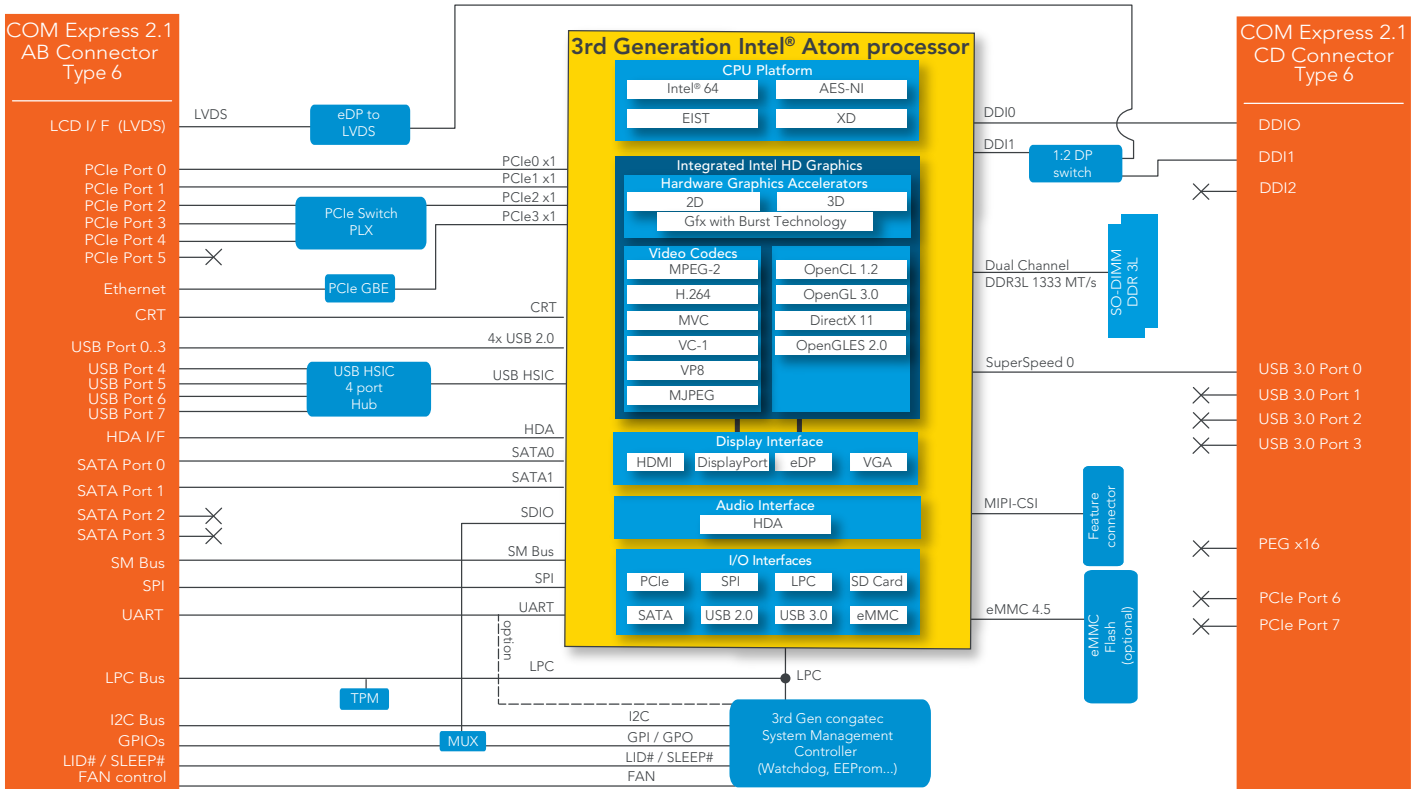

# conga-TCA3 | Order Information

Article	PN	Description
conga-TCA3/E3845	047300	Intel® Atom™ E3845 quad core processor with 1.91GHz, 2MB L2 cache and 1333MT/s dual channel DDR3L memory interface.
conga-TCA3/E3827	047301	Intel® Atom™ E3827 dual core processor with 1.75GHz, 1MB L2 cache and 1333MT/s dual channel DDR3L memory interface.
conga-TCA3/E3826	047302	Intel® Atom™ E3826 dual core processor with 1.46GHz, 1MB L2 cache and 1066MT/s dual channel DDR3L memory interface.
conga-TCA3/E3825	047303	Intel® Atom™ E3825 dual core processor with 1.33GHz, 1MB L2 cache and 1066MT/s single channel DDR3L memory interface.
conga-TCA3/E3815	047304	Intel® Atom™ E3815 single core processor with 1.46GHz, 512kB L2 cache and 1066MT/s single channel DDR3L memory interface.
conga-TCA3/i-E3845	047310	Intel® Atom™ E3845 quad core processor with 1.91GHz, 2MB L2 cache and 1333MT/s dual channel DDR3L memory interface. Industrial grade temperature range from -40°C to 85°C.
conga-TCA3/i-E3827	047311	Intel® Atom™ E3827 dual core processor with 1.75GHz, 1MB L2 cache and 1333MT/s dual channel DDR3L memory interface. Industrial grade temperature range from -40°C to 85°C.
conga-TCA3/i-E3826	047312	Intel® Atom™ E3826 dual core processor with 1.46GHz, 1MB L2 cache and 1066MT/s dual channel DDR3L memory interface. Industrial grade temperature range from -40°C to 85°C.
conga-TCA3/i-E3815	047314	Intel® Atom™ E3815 single core processor with 1.46GHz, 512kB L2 cache and 1066MT/s single channel DDR3L memory interface. Industrial grade temperature range from -40°C to 85°C.
conga-TCA3/J1900	047305	Intel® Celeron® J1900 quad core processor with 2.00GHz, 2MB L2 cache and 1333MT/s dual channel DDR3L memory interface.
conga-TCA3/N2930	047307	Intel® Celeron® N2930 quad core processor with 1.83GHz up to 2.16GHz, 2MB L2 cache and 1333MT/s dual channel DDR3L memory interface.
conga-TCA3/N2807	047308	Intel® Celeron® N2807 dual core processor with 1.58GHz up to 2.16GHz, 1MB L2 cache and 1333MT/s single channel DDR3L memory interface. Ultra-low power consumption with 4.5W TDP.
TCA3/HSP-T	047350	Standard heatspreader for COM Express module conga-TCA3. All standoffs are M2.5 thread.
TCA3/HSP-B	047351	Standard heatspreader for COM Express module conga-TCA3. All standoffs are 2.7mm bore hole.
TCA3/CSP-T	047352	Standard passive cooling solution for COM Express module conga-TCA3 with 20mm overall heat sink height. All standoffs are M2.5mm thread.
TCA3/CSP-B	047353	Standard passive cooling solution for COM Express module conga-TCA3 with 20mm overall heat sink height. All standoffs are 2.7mm bore hole.
DDR3L-SODIMM-1600 (2GB)	068755	DDR3L SODIMM memory module with 1600 MT/s (PC3L-12800S) and 2GB RAM
DDR3L-SODIMM-1600 (4GB)	068756	DDR3L SODIMM memory module with 1600 MT/s (PC3L-12800S) and 4GB RAM
DDR3L-SODIMM-1600 (8GB)	068757	DDR3L SODIMM memory module with 1600 MT/s (PC3L-12800S) and 8GB RAM
DDR3L-SODIMM-1600 (2GB) industrial	068782	Industrial DDR3L SODIMM memory module with 1600 MT/s (PC3L-12800S) and 2GB RAM
DDR3L-SODIMM-1600 (4GB) industrial	068783	Industrial DDR3L SODIMM memory module with 1600 MT/s (PC3L-12800S) and 4GB RAM
DDR3L-SODIMM-1600 (8GB) industrial	068784	Industrial DDR3L SODIMM memory module with 1600 MT/s (PC3L-12800S) and 8GB RAM
<b>Accessories</b>		
conga-TEVAL	065800	Evaluation carrier board for Type 6 COM-Express-modules
conga-LDVI/EPI	011115	LVDS to DVI converter board for digital flat panels with onboard EEPROM
COM-Express-carrier-board-Socket-5	400007	Connector for COM-Express carrier boards   height 5mm   packing unit 4 pieces
COM-Express-carrier-board-Socket-8	400004	Connector for COM-Express carrier boards   height 8mm   packing unit 4 pieces



Компания «ЭлектроПласт» предлагает заключение долгосрочных отношений при поставках импортных электронных компонентов на взаимовыгодных условиях!

Наши преимущества:

- Оперативные поставки широкого спектра электронных компонентов отечественного и импортного производства напрямую от производителей и с крупнейших мировых складов;
- Поставка более 17-ти миллионов наименований электронных компонентов;
- Поставка сложных, дефицитных, либо снятых с производства позиций;
- Оперативные сроки поставки под заказ (от 5 рабочих дней);
- Экспресс доставка в любую точку России;
- Техническая поддержка проекта, помощь в подборе аналогов, поставка прототипов;
- Система менеджмента качества сертифицирована по Международному стандарту ISO 9001;
- Лицензия ФСБ на осуществление работ с использованием сведений, составляющих государственную тайну;
- Поставка специализированных компонентов (Xilinx, Altera, Analog Devices, Intersil, Interpoint, Microsemi, Aeroflex, Peregrine, Syfer, Eurofarad, Texas Instrument, Miteq, Cobham, E2V, MA-COM, Hittite, Mini-Circuits, General Dynamics и др.);

Помимо этого, одним из направлений компании «ЭлектроПласт» является направление «Источники питания». Мы предлагаем Вам помощь Конструкторского отдела:

- Подбор оптимального решения, техническое обоснование при выборе компонента;
- Подбор аналогов;
- Консультации по применению компонента;
- Поставка образцов и прототипов;
- Техническая поддержка проекта;
- Защита от снятия компонента с производства.



#### Как с нами связаться

**Телефон:** 8 (812) 309 58 32 (многоканальный)

**Факс:** 8 (812) 320-02-42

**Электронная почта:** [org@eplast1.ru](mailto:org@eplast1.ru)

**Адрес:** 198099, г. Санкт-Петербург, ул. Калинина, дом 2, корпус 4, литера А.