

# Ø 172x51 mm

**San Ace 172**      Only standard fans (without sensors) have acquired CSA certification. Round type

## General Specifications

- Material ..... Frame: Aluminum, Impeller: Plastic (Flammability: UL 94V-1)
- Expected life ..... See the table below. (L10 life: 90% survival rate for continuous operation in free air at 60°C, rated voltage)
- Motor structure ..... Capacitor motor
- Motor protection function ..... Locked rotor burnout protection, Reverse polarity protection  
For details, please refer to p. 547.
- Dielectric strength ..... 50/60 Hz, 1500 VAC, for 1 minute (between input terminal and frame)
- Dielectric strength (with sensor) ..... 50/60 Hz 1500 VAC 1 minute (between AC input terminal and frame)  
50/60 Hz 1000 VAC 1 minute (between lead wire conductors and frame)
- Insulation resistance ..... 10 MΩ or more with a 500 VDC megger
- Sound pressure level (SPL) ..... At 1 m away from the air inlet
- Operating voltage range ..... Voltage of each model ±10%
- Storage temperature ..... -30 to +70°C (Non-condensing)
- Sensor-Purpose lead wire ..... ⊕Brown ⊖Black (Sensor) Yellow
- Mass ..... 1000 g

## Specifications

### Standard

Model no.	Rated voltage [V]	Frequency [Hz]	Input [W]	Current [A]	Locked rotor current [A]	Rated speed [min <sup>-1</sup> ]	Max. airflow [m <sup>3</sup> /min] [CFM]	Max. static pressure [Pa] [inchH <sub>2</sub> O]	SPL [dB (A)]	Operating temperature [°C]	Expected life [h]
109-311	100	50/60	27/25	0.33/0.25	0.65/0.64	2900/3500	5.3/6.4 187.3/226.1	147/196 0.59/0.787	47/51	-30 to +60	25000/60°C
109-314	115			0.29/0.22	0.55/0.54						
109-312	200			0.16/0.13	0.33/0.32						
109-313	230			0.14/0.11	0.28/0.27						

### with Sensor

For sensor specifications, please refer to p. 550. Sensor specification differs depending on the fan's speed specification.

For a 5 V sensor power supply (ITEM-20), please append "-20" to the end of model number. E.g. 109-371-20

For a 12 V sensor power supply (ITEM-30), please append "-30" to the end of model number. E.g. 109-371-30

Model no.	Rated voltage [V]	Frequency [Hz]	Input [W]	Current [A]	Locked rotor current [A]	Rated speed [min <sup>-1</sup> ]	Max. airflow [m <sup>3</sup> /min] [CFM]	Max. static pressure [Pa] [inchH <sub>2</sub> O]	SPL [dB (A)]	Operating temperature [°C]	Expected life [h]
109-371	100	50/60	27/25	0.33/0.25	0.65/0.64	2900/3500	5.3/6.4 187.3/226.1	147/196 0.59/0.787	47/51	-10 to +60	25000/60°C
109-374	115			0.29/0.22	0.55/0.54						
109-372	200			0.16/0.13	0.33/0.32						
109-373	230			0.14/0.11	0.28/0.27						

## Set Models

Fan, finger guard, plug cord, screws, etc. can be purchased in one package. For details, please refer to p. 594.

Order no.	Set items					
	Fan	Voltage	Low-speed sensor	Plug cord*	Finger guards	Mounting screws
ST1-109-311	109-311	100 V		489-1619-L10	109-319E	M4x25 mm (4 screws)
ST1-109-314	109-314	115 V		489-1619-L10	109-319E	
ST1-109-312	109-312	200 V		489-1619-L10	109-319E	
ST1-109-313	109-313	230 V		489-1619-L10	109-319E	
ST1-109-371-20	109-371-20	100 V	○ (5 V)	489-1619-L10	109-319E	
ST1-109-371-30	109-371-30		○ (12 V)	489-1619-L10	109-319E	
ST1-109-374-20	109-374-20	115 V	○ (5 V)	489-1619-L10	109-319E	
ST1-109-374-30	109-374-30		○ (12 V)	489-1619-L10	109-319E	
ST1-109-372-20	109-372-20	200 V	○ (5 V)	489-1619-L10	109-319E	
ST1-109-372-30	109-372-30		○ (12 V)	489-1619-L10	109-319E	
ST1-109-373-20	109-373-20	230 V	○ (5 V)	489-1619-L10	109-319E	
ST1-109-373-30	109-373-30		○ (12 V)	489-1619-L10	109-319E	

\* PSE compatible.

## Airflow - Static Pressure Characteristics

### Standard

109-311, 109-314, 109-312, 109-313



### with Sensor

109-371, 109-374, 109-372, 109-373



## Dimensions (unit: mm)

### Standard

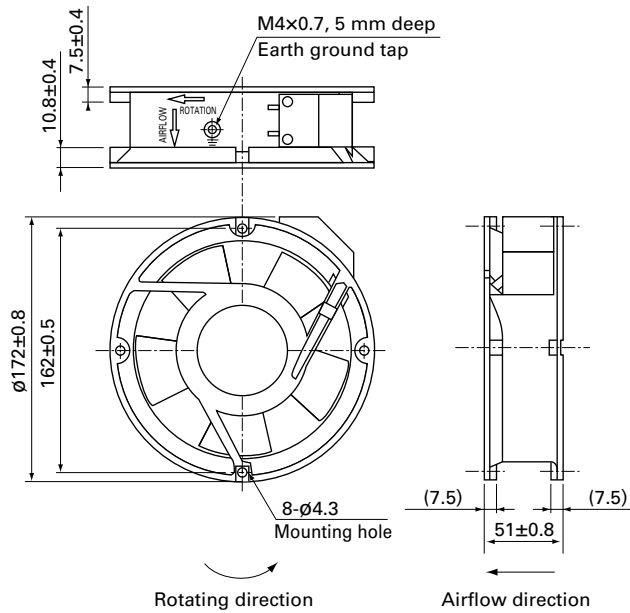

### with Sensor



## Reference Dimensions of Mounting Holes and Vent Opening (unit: mm)

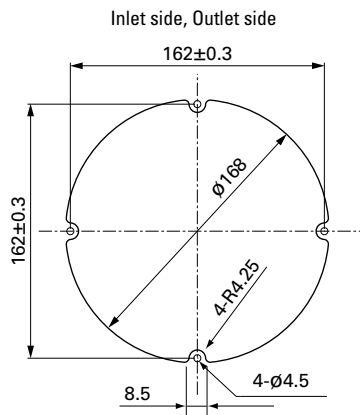

## Wiring Diagram

### Standard



### with Sensor

For fan power supply



For sensor circuit  
5 V (ITEM-20)

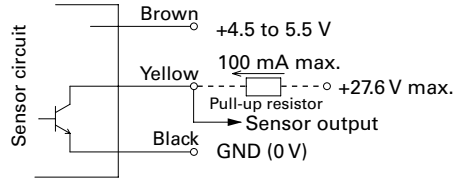

12 V (ITEM-30)

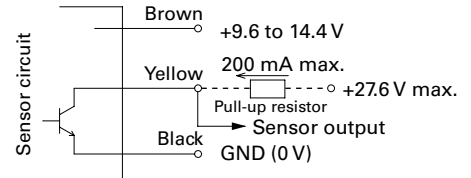

GND (Black) should be shared in case that power supply for sensor circuit (Brown) and that for sensor pull-up (Yellow) are separated.

## Options

### Finger guards

page: p. 534

Model no.: 109-319E, 109-319H, 109-320, 109-1066,  
109-1068

### Plug cord

page: pp. 542 to 543

Model no.: 489-1619-L10, 489-1619-L21, 489-084-L10,  
489-084-L21



Компания «ЭлектроПласт» предлагает заключение долгосрочных отношений при поставках импортных электронных компонентов на взаимовыгодных условиях!

Наши преимущества:

- Оперативные поставки широкого спектра электронных компонентов отечественного и импортного производства напрямую от производителей и с крупнейших мировых складов;
- Поставка более 17-ти миллионов наименований электронных компонентов;
- Поставка сложных, дефицитных, либо снятых с производства позиций;
- Оперативные сроки поставки под заказ (от 5 рабочих дней);
- Экспресс доставка в любую точку России;
- Техническая поддержка проекта, помощь в подборе аналогов, поставка прототипов;
- Система менеджмента качества сертифицирована по Международному стандарту ISO 9001;
- Лицензия ФСБ на осуществление работ с использованием сведений, составляющих государственную тайну;
- Поставка специализированных компонентов (Xilinx, Altera, Analog Devices, Intersil, Interpoint, Microsemi, Aeroflex, Peregrine, Syfer, Eurofarad, Texas Instrument, Miteq, Cobham, E2V, MA-COM, Hittite, Mini-Circuits, General Dynamics и др.);

Помимо этого, одним из направлений компании «ЭлектроПласт» является направление «Источники питания». Мы предлагаем Вам помощь Конструкторского отдела:

- Подбор оптимального решения, техническое обоснование при выборе компонента;
- Подбор аналогов;
- Консультации по применению компонента;
- Поставка образцов и прототипов;
- Техническая поддержка проекта;
- Защита от снятия компонента с производства.



#### Как с нами связаться

**Телефон:** 8 (812) 309 58 32 (многоканальный)

**Факс:** 8 (812) 320-02-42

**Электронная почта:** [org@eplast1.ru](mailto:org@eplast1.ru)

**Адрес:** 198099, г. Санкт-Петербург, ул. Калинина, дом 2, корпус 4, литера А.