

Wide-band, dual-path directional coupler with ISO port

Features

- 50 Ω nominal input / output impedance
- Wide operating frequency range:
 - 824 MHz-2170 MHz
- Low insertion loss (< 0.2 dB)
- High directivity (> 20 dB)
- High ESD ruggedness
- Lead-free CSP package
- Small footprint: 1670 x 1440 μm
- Very low profile (< 650 μm thickness)

Benefits

- High RF performance
- RF module size reduction

Complies with the following standards:

- IEC 61000-4-2 level 4:
 - 15 kV (air discharge)
 - 8 kV (contact discharge)

Applications

Multi-band equipment such as:

- Power amplifier module
- Front end module
- GSM/WCDMA mobile phone

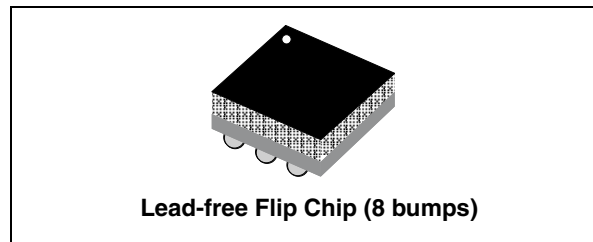
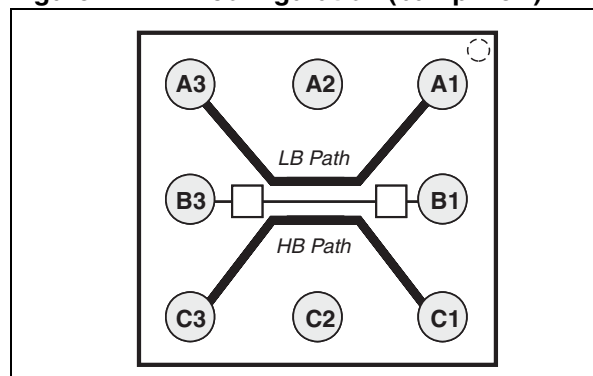

Figure 1. Pin configuration (bump view)



Description

The DCPL-WB-00D3 is a wide-band, dual-path directional coupler designed to measure cell phone transmission output power in GSM/WCDMA applications. This dual path CPL has been customized for wide-band operating frequencies (EGSM and CELL, PCS, DCS, WCDMA band I) with less than 0.2 dB insertion losses in the transmission bandwidth (824 MHz - 1980 MHz).

This device is built with two different RF couplers (one dedicated to LB, the other dedicated to HB) sharing the same coupled and isolated ports. The DCPL-WB-00-D3 has been designed using STMicroelectronics IPD (integrated passive device) technology on non-conductive glass substrate to optimize RF performance.

The device is delivered 100% tested in tape and reel.

1 Characteristics

Table 1. Device pin configuration

Bump	Name	Description
A1	Lbin	LB coupler RF input
A2	GND	RF ground
A3	Lbout	LB coupler RF output
B1	CPLD	Coupler port
B3	ISO	Isolated port
C1	Hbin	HB coupler RF input
C2	GND	RF ground
C3	Hbout	HB coupler output

Table 2. Absolute maximum rating (limiting values)

Symbol	Parameter	Value			Unit
		Min.	Typ.	Max.	
P_{IN}	Input Power RF_{IN} (CW mode)			35	dBm
$V_{ESD (IEC)}$	ESD ratings IEC 61000-4-2 (C = 150 pF, R = 330 Ω) LB _{IN} , LB _{OUT} , HB _{IN} , HB _{OUT} , air discharge LB _{IN} , LB _{OUT} , HB _{IN} , HB _{OUT} , contact discharge	± 15 ± 8			kV
$V_{ESD (HBM)}$	Human body model, JESD 22-A114F, all I/O	2			kV
$V_{ESD (MM)}$	Machine model, JESD 22-A115-A, all I/O	100			V
$V_{ESD (CDM)}$	Charge device model, JESD 22-C101-C, all I/O	500			V
T_{OP}	Operating temperature	-30		+85	$^{\circ}C$

Table 3. Electrical characteristics - impedances ($T_{amb} = 25^{\circ}C$)

Symbol	Parameter	Value			Unit
		Min.	Typ.	Max.	
Z_{OUT}	Nominal output impedance (LB and HB paths)		50		Ω
Z_{IN}	Nominal input impedance (LB and HB paths)		50		Ω
Z_{CPL}	Nominal coupled port impedance		50		Ω
Z_{ISO}	Nominal isolated port impedance		50		Ω

Table 4. Electrical characteristics - LB path RF performance ($T_{amb} = 25\text{ °C}$)

Symbol	Parameter	Test condition	Value			Unit
			Min.	Typ.	Max.	
f	Frequency range (bandwidth)		824		960	MHz
IL _{LB}	LB path insertion loss	From 824 MHz to 960 MHz		0.1	0.2	dB
RL _{LB}	LB path return loss	From 824 MHz to 960 MHz	15			dB
CPLD _{LB}	LB path coupling factor	From 824 MHz to 915 MHz	32		37	dB
Ripple _{LB}	Coupling ripple in LB	(824 to 849 MHz) (880 to 915 MHz)			0.5	dB
DIR _{LB}	LB coupler directivity	From 824 MHz to 915 MHz	20			dB

Table 5. Electrical characteristics - HB path RF performance ($T_{amb} = 25\text{ °C}$)

Symbol	Parameter	Test condition	Value			Unit
			Min.	Typ.	Max.	
f	Frequency range (bandwidth)		1710		1980	MHz
IL _{HB}	HB path insertion loss	From 1710 MHz to 2170 MHz		0.1	0.2	dB
RL _{HB}	HB path return loss	From 1710 MHz to 2170 MHz	15			dB
CPLD _{HB}	HB path coupling factor	From 1710 MHz to 1980 MHz	29		34	dB
Ripple _{H B}	Coupling ripple in HB	(1710 to 1785 MHz) (1850 to 1910 MHz) (1920 to 1980 MHz)			0.5	dB
DIR _{HB}	HB coupler directivity	From 1710 MHz to 1980 MHz	20			dB

1.1 RF measurement (on reference evaluation board)

Measurements done on reference evaluation board under 50 Ω , de-embedding at DCPL-WB-00D3 bumps.

Figure 2. Low band path insertion loss

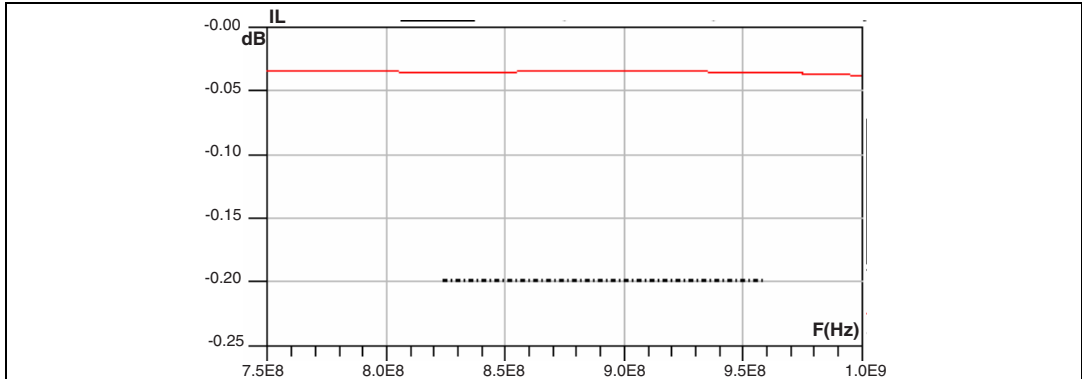

Figure 3. High band path insertion loss

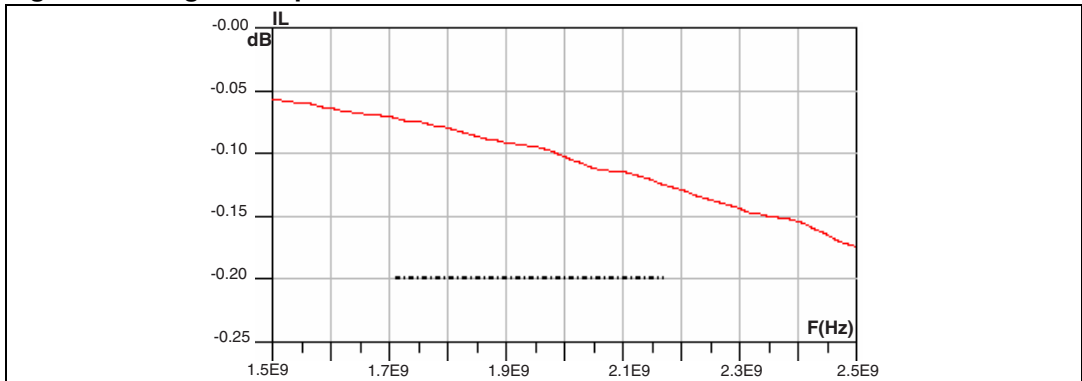

Figure 4. Low band path coupling factor

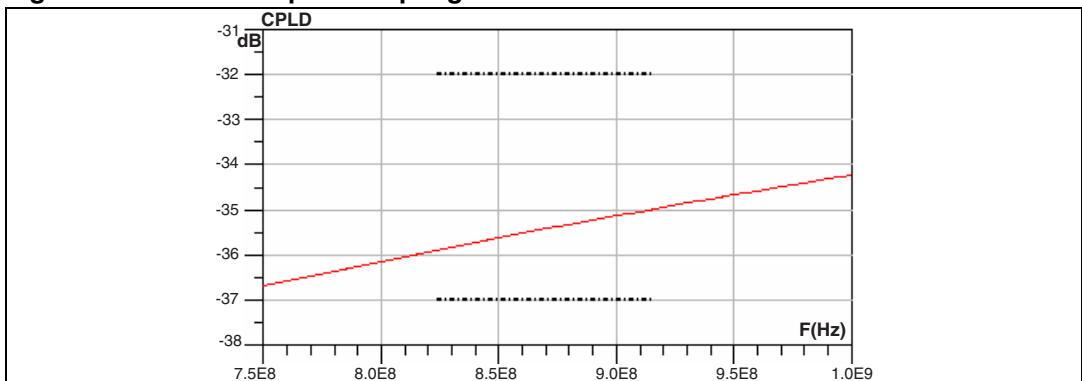

Figure 5. High band path coupling factor

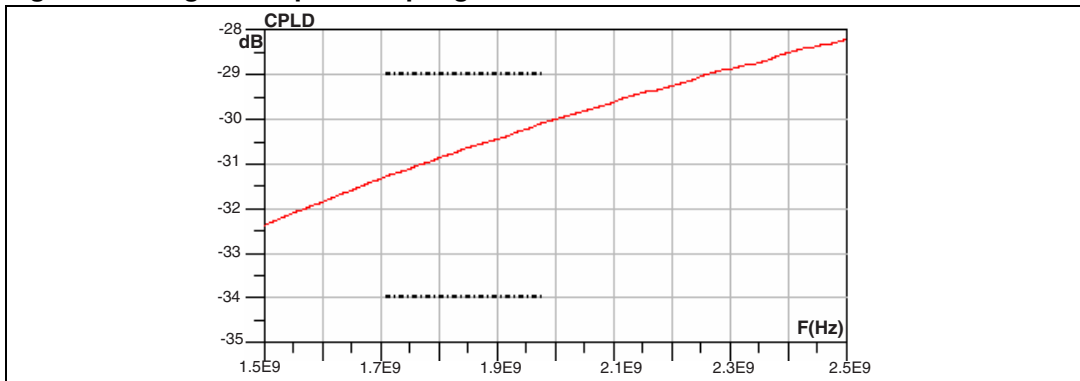

Figure 6. Low band path directivity

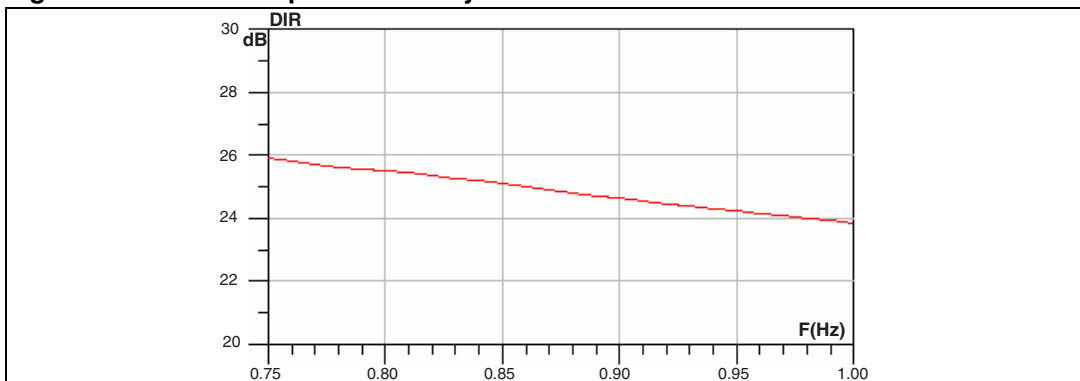

Figure 7. High band path directivity

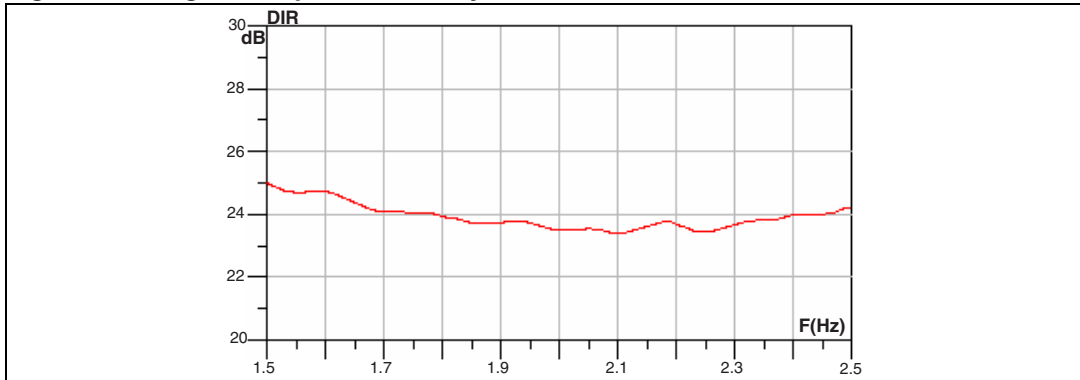

Figure 8. Demo board description - layer 1

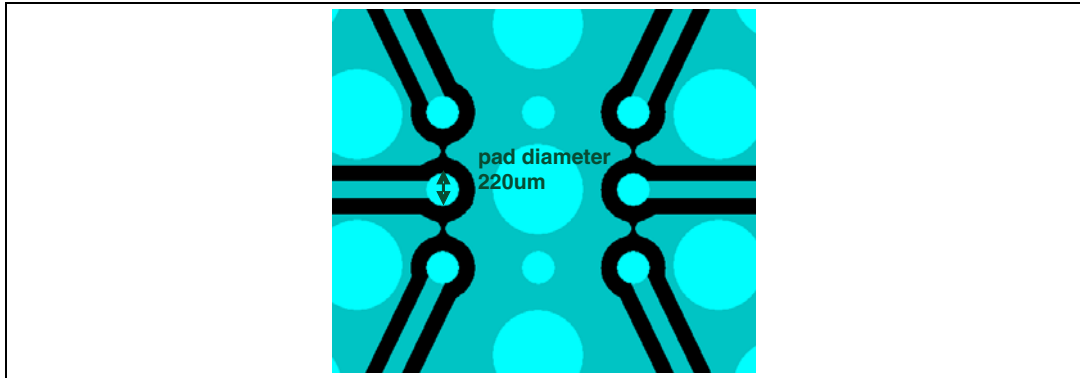
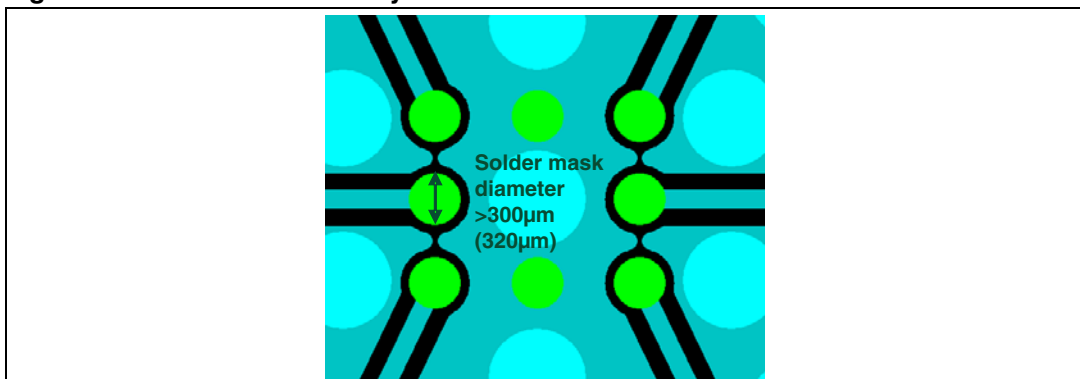
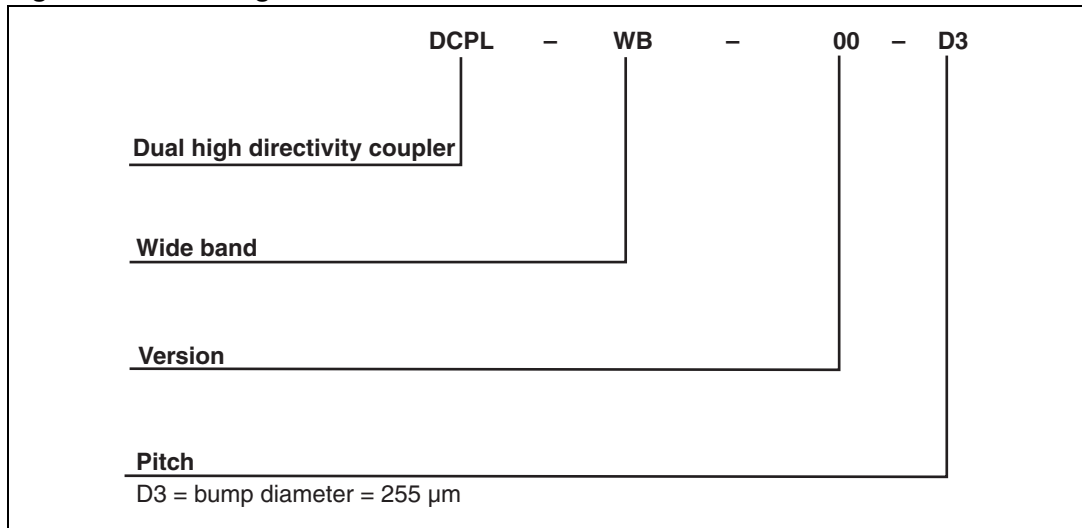

Figure 9. Solder mask 1 + layer 1



2 Ordering information scheme

Figure 10. Ordering information scheme



3 Package information

In order to meet environmental requirements, ST offers these devices in different grades of ECOPACK® packages, depending on their level of environmental compliance. ECOPACK® specifications, grade definitions and product status are available at: www.st.com. ECOPACK® is an ST trademark.

Figure 11. Package dimensions

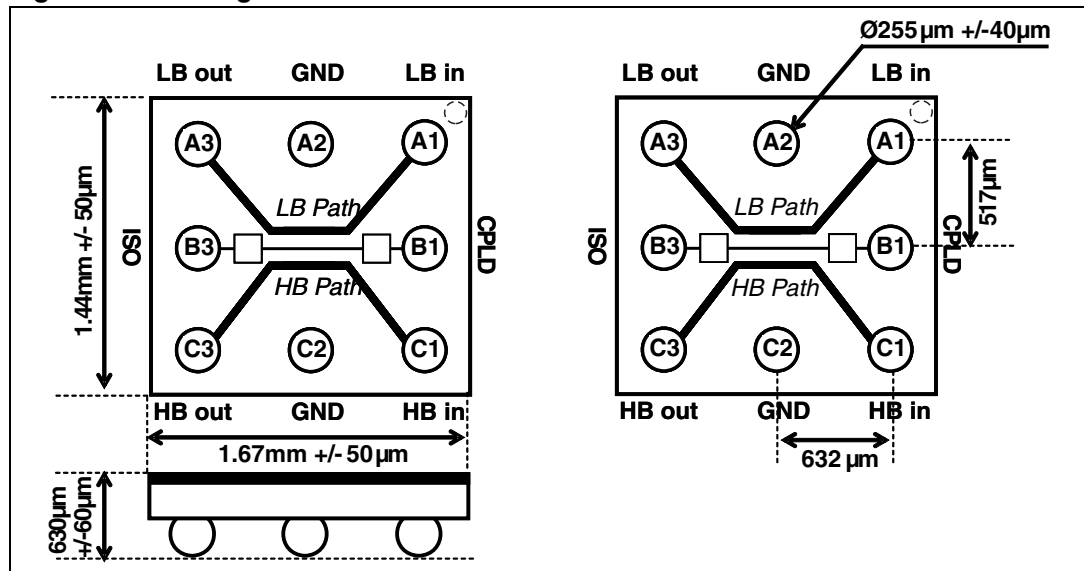

Figure 12. Footprint

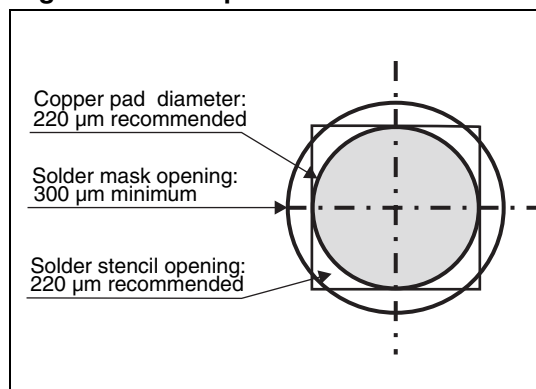

Figure 13. Marking

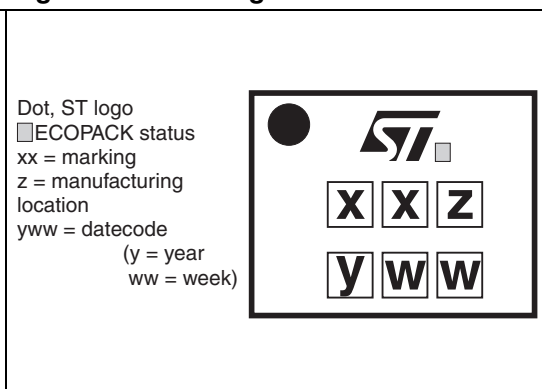
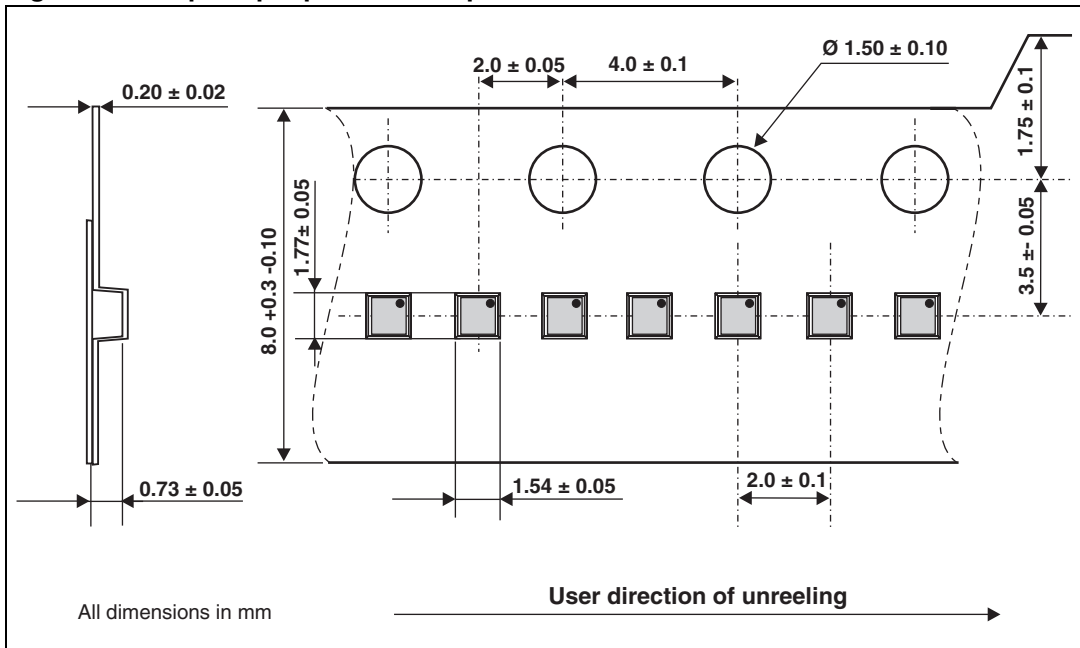

Figure 14. Flip-Chip tape and reel specifications



Note: More packing information is available in the application notes:
AN2348: “400 μ m Flip-Chip: Package description and recommendations for use”
AN1751: “EMI Filters: Recommendations and measurements”

4 Ordering information

Table 6. Ordering information

Order code	Marking	Package	Weight	Base qty	Delivery mode
DCPL-WB-00D3	RS	Flip Chip	2.5 mg	5000	Tape and reel 7"

5 Revision history

Table 7. Document revision history

Date	Revision	Changes
14-Apr-2010	1	Initial release

Please Read Carefully:

Information in this document is provided solely in connection with ST products. STMicroelectronics NV and its subsidiaries ("ST") reserve the right to make changes, corrections, modifications or improvements, to this document, and the products and services described herein at any time, without notice.

All ST products are sold pursuant to ST's terms and conditions of sale.

Purchasers are solely responsible for the choice, selection and use of the ST products and services described herein, and ST assumes no liability whatsoever relating to the choice, selection or use of the ST products and services described herein.

No license, express or implied, by estoppel or otherwise, to any intellectual property rights is granted under this document. If any part of this document refers to any third party products or services it shall not be deemed a license grant by ST for the use of such third party products or services, or any intellectual property contained therein or considered as a warranty covering the use in any manner whatsoever of such third party products or services or any intellectual property contained therein.

UNLESS OTHERWISE SET FORTH IN ST'S TERMS AND CONDITIONS OF SALE ST DISCLAIMS ANY EXPRESS OR IMPLIED WARRANTY WITH RESPECT TO THE USE AND/OR SALE OF ST PRODUCTS INCLUDING WITHOUT LIMITATION IMPLIED WARRANTIES OF MERCHANTABILITY, FITNESS FOR A PARTICULAR PURPOSE (AND THEIR EQUIVALENTS UNDER THE LAWS OF ANY JURISDICTION), OR INFRINGEMENT OF ANY PATENT, COPYRIGHT OR OTHER INTELLECTUAL PROPERTY RIGHT.

UNLESS EXPRESSLY APPROVED IN WRITING BY AN AUTHORIZED ST REPRESENTATIVE, ST PRODUCTS ARE NOT RECOMMENDED, AUTHORIZED OR WARRANTED FOR USE IN MILITARY, AIR CRAFT, SPACE, LIFE SAVING, OR LIFE SUSTAINING APPLICATIONS, NOR IN PRODUCTS OR SYSTEMS WHERE FAILURE OR MALFUNCTION MAY RESULT IN PERSONAL INJURY, DEATH, OR SEVERE PROPERTY OR ENVIRONMENTAL DAMAGE. ST PRODUCTS WHICH ARE NOT SPECIFIED AS "AUTOMOTIVE GRADE" MAY ONLY BE USED IN AUTOMOTIVE APPLICATIONS AT USER'S OWN RISK.

Resale of ST products with provisions different from the statements and/or technical features set forth in this document shall immediately void any warranty granted by ST for the ST product or service described herein and shall not create or extend in any manner whatsoever, any liability of ST.

ST and the ST logo are trademarks or registered trademarks of ST in various countries.

Information in this document supersedes and replaces all information previously supplied.

The ST logo is a registered trademark of STMicroelectronics. All other names are the property of their respective owners.

© 2011 STMicroelectronics - All rights reserved

STMicroelectronics group of companies

Australia - Belgium - Brazil - Canada - China - Czech Republic - Finland - France - Germany - Hong Kong - India - Israel - Italy - Japan - Malaysia - Malta - Morocco - Philippines - Singapore - Spain - Sweden - Switzerland - United Kingdom - United States of America

www.st.com





Компания «ЭлектроПласт» предлагает заключение долгосрочных отношений при поставках импортных электронных компонентов на взаимовыгодных условиях!

Наши преимущества:

- Оперативные поставки широкого спектра электронных компонентов отечественного и импортного производства напрямую от производителей и с крупнейших мировых складов;
- Поставка более 17-ти миллионов наименований электронных компонентов;
- Поставка сложных, дефицитных, либо снятых с производства позиций;
- Оперативные сроки поставки под заказ (от 5 рабочих дней);
- Экспресс доставка в любую точку России;
- Техническая поддержка проекта, помощь в подборе аналогов, поставка прототипов;
- Система менеджмента качества сертифицирована по Международному стандарту ISO 9001;
- Лицензия ФСБ на осуществление работ с использованием сведений, составляющих государственную тайну;
- Поставка специализированных компонентов (Xilinx, Altera, Analog Devices, Intersil, Interpoint, Microsemi, Aeroflex, Peregrine, Syfer, Eurofarad, Texas Instrument, Miteq, Cobham, E2V, MA-COM, Hittite, Mini-Circuits, General Dynamics и др.);

Помимо этого, одним из направлений компании «ЭлектроПласт» является направление «Источники питания». Мы предлагаем Вам помощь Конструкторского отдела:

- Подбор оптимального решения, техническое обоснование при выборе компонента;
- Подбор аналогов;
- Консультации по применению компонента;
- Поставка образцов и прототипов;
- Техническая поддержка проекта;
- Защита от снятия компонента с производства.



Как с нами связаться

Телефон: 8 (812) 309 58 32 (многоканальный)

Факс: 8 (812) 320-02-42

Электронная почта: org@eplast1.ru

Адрес: 198099, г. Санкт-Петербург, ул. Калинина, дом 2, корпус 4, литера А.