



LC Series
Basic Evaluation Kit
User's Guide

Wireless made simple[®]

Warning: Some customers may want Linx radio frequency (“RF”) products to control machinery or devices remotely, including machinery or devices that can cause death, bodily injuries, and/or property damage if improperly or inadvertently triggered, particularly in industrial settings or other applications implicating life-safety concerns (“Life and Property Safety Situations”).

NO OEM LINX REMOTE CONTROL OR FUNCTION MODULE SHOULD EVER BE USED IN LIFE AND PROPERTY SAFETY SITUATIONS. No OEM Linx Remote Control or Function Module should be modified for Life and Property Safety Situations. Such modification cannot provide sufficient safety and will void the product’s regulatory certification and warranty.

Customers may use our (non-Function) Modules, Antenna and Connectors as part of other systems in Life Safety Situations, but only with necessary and industry appropriate redundancies and in compliance with applicable safety standards, including without limitation, ANSI and NFPA standards. It is solely the responsibility of any Linx customer who uses one or more of these products to incorporate appropriate redundancies and safety standards for the Life and Property Safety Situation application.

Do not use this or any Linx product to trigger an action directly from the data line or RSSI lines without a protocol or encoder/decoder to validate the data. Without validation, any signal from another unrelated transmitter in the environment received by the module could inadvertently trigger the action.

All RF products are susceptible to RF interference that can prevent communication. RF products without frequency agility or hopping implemented are more subject to interference. This module does not have a frequency hopping protocol built in.

Do not use any Linx product over the limits in this data guide. Excessive voltage or extended operation at the maximum voltage could cause product failure. Exceeding the reflow temperature profile could cause product failure which is not immediately evident.

Do not make any physical or electrical modifications to any Linx product. This will void the warranty and regulatory and UL certifications and may cause product failure which is not immediately evident.

Table of Contents

- 1 [Introduction](#)
- 2 [Ordering Information](#)
- 2 [LC Transmitter Evaluation Board](#)
- 3 [LR Receiver Evaluation Board](#)
- 4 [Theory of Operation](#)
- 4 [Using the Kit](#)
- 5 [Development Using the Prototyping Area](#)
- 6 [Range Testing](#)
- 7 [Using the Boards as a Design Reference](#)
- 8 [About Antennas](#)
- 8 [In Closing](#)
- 9 [Online Resources](#)
- 10 [LR Receiver Evaluation Board Schematic](#)
- 11 [LC Transmitter Evaluation Board Schematic](#)

LC Series Basic Evaluation Kit

User's Guide

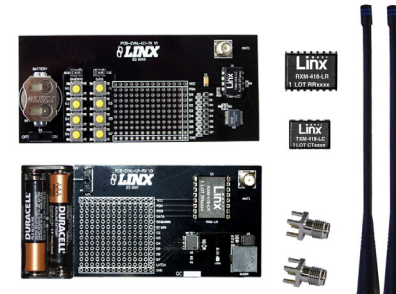

Figure 1: LC Series Basic Evaluation Kit

Introduction

LinX LC Series RF modules offer a simple, efficient, and cost-effective method of adding wireless communication capabilities to any product. The Basic Evaluation Kit gives a designer all the tools necessary to correctly and legally incorporate the LC Series modules into an end product. The development boards themselves serve several important functions:

- **Rapid Module Evaluation:** The boards allow the performance of the LC Series modules to be evaluated quickly in a user's environment.
- **Range Testing:** Using the on-board encoders and decoders to generate a simplex transmission, a pair of evaluation boards can be used to evaluate the range performance of the modules.
- **Design Benchmark:** The boards provide a known benchmark against which the performance of a custom design may be judged.
- **Application Development:** An onboard prototyping area allows for the development of custom circuits directly on the evaluation board. All signal lines are available on a header for easy access.

The kit includes 2 LC Series transmitters*, 2 LR Series receivers*, 2 extra PCB-mount RP-SMA connectors, 2 evaluation boards, 2 CW Series antennas, 1 CR2032 battery, 2 AAA batteries and full documentation.

* One part is soldered to each board. One extra is for use on your first prototype boards.

Ordering Information

Ordering Information	
Part Number	Description
EVAL-***-LC	LC Series Basic Evaluation Kit
*** = 315, 418 (Standard), 433MHz	

Figure 2: Ordering Information

LC Transmitter Evaluation Board

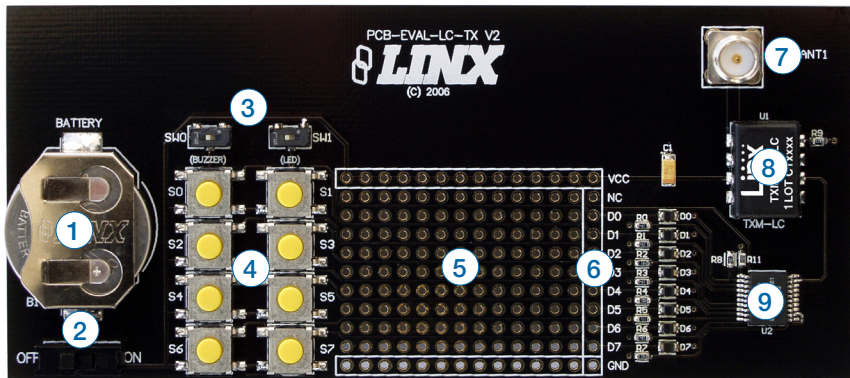

Figure 3: LC Transmitter Evaluation Board

1. Battery - 3VDC (use a CR2032-style battery only)
2. Power Switch
3. Continuous ON Switches
4. Momentary Pushbuttons
5. Prototyping Area
6. Breakout Header
7. Reverse-Polarity SMA Antenna Connector
8. LC Series Transmitter Module
9. MS Series Encoder

LR Receiver Evaluation Board

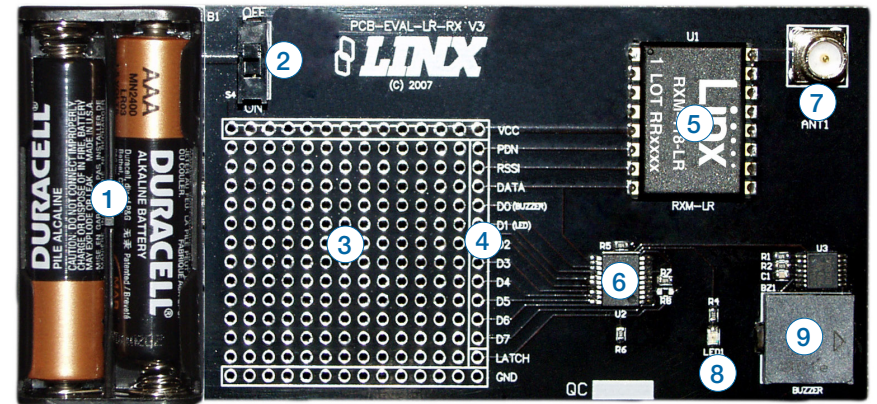

Figure 4: LR Receiver Evaluation Board

1. Battery – 3VDC (use 2 AAA style batteries only)
2. Power Switch
3. Prototyping Area
4. Breakout Header
5. LR Series Receiver Module
6. MS Series Decoder
7. Reverse-Polarity SMA Antenna Connector
8. LED - D1
9. Buzzer - D0

Theory of Operation

Transmitter Evaluation Board

The transmitter board is powered by an on-board 3V CR2032 lithium battery. It has eight SPST pushbutton switches, the state of which is encoded into a data stream using a Linx MS Series encoder. If a switch is closed, the transmitter is enabled while the encoder captures the pushbutton states for encoding and transmission. The encoder powers down the transmitter when the button is released. All of the data lines have been wired out to the header to the right of the prototyping area and can be accessed for use with other switches, contacts or microcontrollers.

Receiver Evaluation Board

The receiver board is powered by two AAA batteries. The LR Series receiver exhibits a sensitivity of greater than -112dBm , so under optimum line-of-sight conditions, the transmitter / receiver link can operate over distances of up to 3,000 feet (1,000m). The data recovered by the LR Series receiver is decoded by a MS Series decoder, and the data lines are updated to match the state of the data lines (or pushbuttons) on the transmitter board. To demonstrate this, one data line is used to drive a LED while another is used to activate a buzzer. This board also has a prototyping area with all of the receiver and decoder lines brought out to a header.

Using the Kit

Using the kit is straightforward. Simply attach the antennas, turn on the power and press buttons on the transmitter board. When S0 is pressed, the buzzer sounds; when S1 is pressed, the LED turns on. When any button (S0–S7) is pressed on the transmitter board, the corresponding decoder output (D0–D7) is active high (V_{CC}) on the prototyping header.

Development Using the Prototyping Area

In addition to their evaluation functions, the boards may also be used for product development. They feature a prototyping area to facilitate the addition of application-specific circuitry. This area has a connection to V_{CC} at the top and ground at the bottom that can be used to power any circuitry that is added.

Note: The CR2032-style battery on the transmitter board has very low current capacity with, only about 3mA available for external circuitry. If added circuitry requires a higher current, the battery must be removed and the board powered from an external source.

The holes are plated and set at 0.1" on center with a 0.04" diameter, making it easy to add most industry-standard SIP and DIP packages to the board.

On the transmitter board, the data lines from the encoder have been wired out to a row of plated holes on the right side of the prototyping area. On the receiver board, the data lines from the decoder plus the RSSI, PDN, and DATA lines from the receiver have been wired out. This allows for easy access to connect external circuitry to the modules, the encoder, and the decoder. Data line D0 is connected to the buzzer and D1 is connected to the LED.

Range Testing

Several complex mathematical models exist for determining path loss in many environments. These models vary as the transmitter and receiver are moved from indoor operation to outdoor operation. Although these models can provide an estimation of range performance in the field, the most reliable method is to simply perform range tests using the transmitter and receiver in the intended operational environment.

Basic range testing can be performed with the transmitter and receiver evaluation boards. To prepare the board for range testing, turn it on by switching the power switch to the ON position. Pressing S0 on the transmitter activates the buzzer on the receiver board, while S1 activates the LED. Switches SW0 and SW1 have been provided to jumper the buttons and continuously transmit. This allows the designer to turn on the transmitter and walk with the receiver.

As the maximum range of the link in an area is approached, it is not uncommon for the signal to cut in and out as the transmitter moves. This is normal and can result from other interfering sources or fluctuating signal levels due to multipath. Multipath results in cancellation of the transmitted signal as direct and reflected signals arrive at the receiver at differing times and phases. The areas in which this occurs are commonly called “nulls” and simply walking a little further usually restores the signal. If this does not restore the signal, then the maximum effective range of the link has been reached.

Since the evaluation boards are intended for use by design engineers, they are not FCC certified. The transmitter has been set to approximate legal limits by resistor R9 so that the range test results will approximate the results from a well-designed, certified product. For applications where Part 15 limits are not applicable or output levels can be legally raised due to protocol duty cycle, R9 can be changed according to the Output Power vs. LADJ Resistance graph in the LC Series Transmitter Module Data Guide.

To achieve maximum range, keep objects such as your hand away from the antenna and ensure that the antenna on the transmitting board has a clear and unobstructed line-of-sight path to the receiving board. Range performance is determined by many interdependent factors. If the range you are able to achieve is significantly less than specified by Linx for the products you are testing, then there is likely a problem with either the board or the ambient RF environment in which the board is operating. First, check

the battery, switch positions, and antenna connection. Next, measure the receiver's RSSI voltage with the transmitter turned off to determine if ambient interference is present. If this fails to resolve the issue, please contact Linx technical support.

Using the Boards as a Design Reference

The basic evaluation boards included in this kit are very simple, yet they illustrate some important techniques that should be incorporated into the board layout. The module's mounting pads extend slightly past the edge of the part. This eases hand assembly and allows for better heat conduction under the part if rework is necessary. A full ground plane fill is placed on the bottom of the board. This ground plane serves three important purposes:

First, since a quarter-wave antenna is employed, the ground plane is critical to serve as a counterpoise (please see Application Note AN-00500 “Antennas: Design, Application, and Performance” for details on how a ground plane affects antenna function).

Second, a ground plane suppresses the transfer of noise between stages of a product as well as unintentional radiation of noise into free space.

Third, a ground plane allows for the implementation of a microstrip feed between the module and the antenna. The term microstrip refers to a PCB trace running over a ground plane that is designed to serve as a 50-ohm transmission line. See the LC Series data guide or the calculator available on our website for details on microstrip calculations.

About Antennas

The choice of antennas is one of the most critical and often overlooked design considerations. The range, performance, and legality of an RF link are critically dependent upon the type of antenna employed. Linx offers a variety of antenna styles that can be considered for a design. Included with your kit are HD Series (315MHz) or CW Series (418MHz and 433MHz) connectorized whip antennas that should be connected prior to using the kit. Despite the fact that the antenna is not centered on the board's ground plane, it exhibits a VSWR of <math><1.7</math> and suitably demonstrates the module's best practical performance.

In Closing

Here at Linx, "Wireless Made Simple" is more than just our motto, it is our commitment. A commitment to the highest caliber of product, service, and support. That is why, should you have questions or encounter any difficulties using the evaluation kit, you'll be glad to know many resources are available to assist you. First, check carefully for the obvious, then visit our website at www.linxtechnologies.com or call +1 541 471 6256 between 8AM and 4PM Pacific Time to speak with an application engineer.

Legal Notice: All Linx kits and modules are designed in keeping with high engineering standards; however, it is the responsibility of the user to ensure that the products are operated in a legal and appropriate manner. The purchaser understands that legal operation may require additional permits, approvals, or certifications prior to use, depending on the country of operation.

Online Resources

www.linxtechnologies.com

If you have questions regarding any Linx product and have Internet access, make www.linxtechnologies.com your first stop. Day or night, the Linx website gives you instant access to the latest information regarding the products and services of Linx. It's all here, including:

- **Manual and Software Updates**
- **Latest News**
- **Data Guides**
- **Application Notes**
- **Knowledgebase**
- **FCC Information**

And much more. Be sure to visit often!

www.antennafactor.com

The Antenna Factor division of Linx offers a diverse array of antenna styles, many of which are optimized for use with our RF modules. From innovative embeddable antennas to low-cost whips, domes to GPS antennas, Antenna Factor likely has an antenna for you, or can design one to meet your requirements.

AntennaFactor
by **Linx**



Figure 5: Antenna Factor Antennas

LR Receiver Evaluation Board Schematic

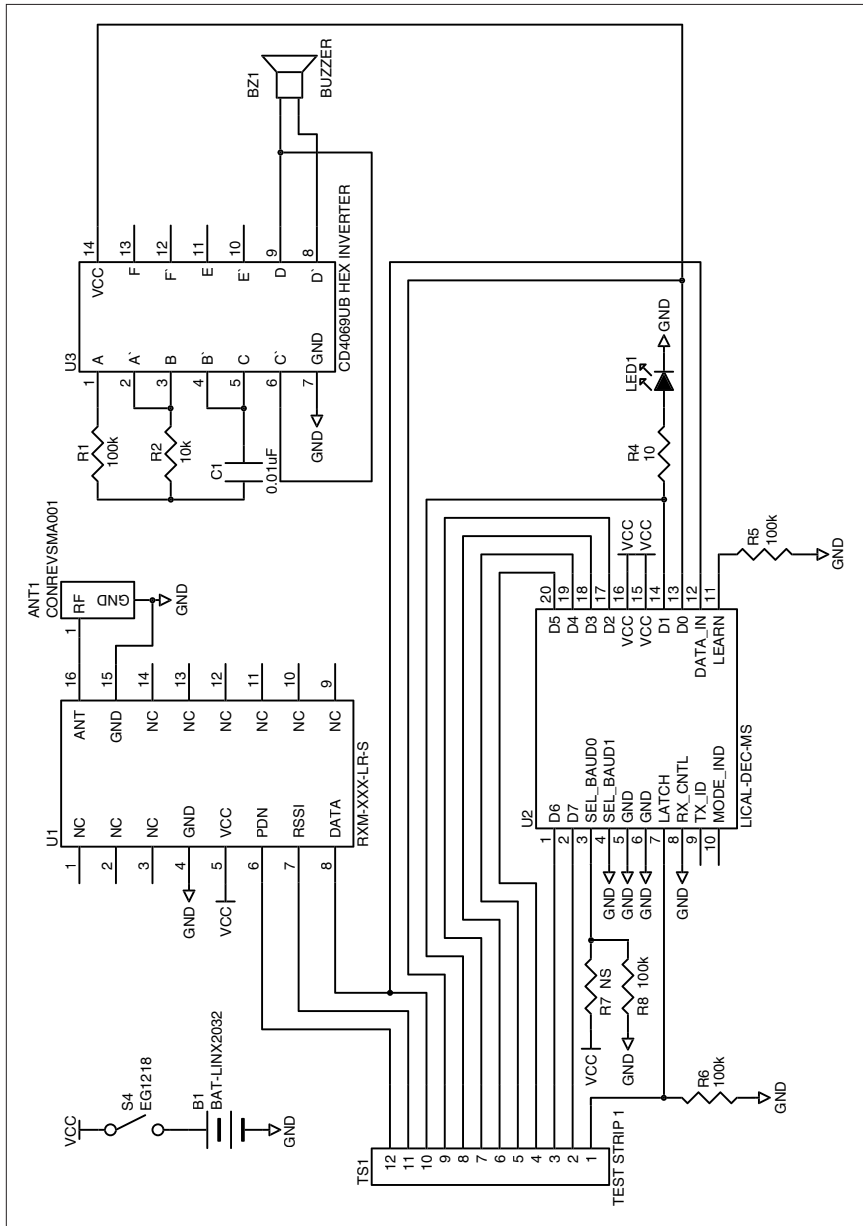

Figure 6: LR Receiver Evaluation Board Schematic

LC Transmitter Evaluation Board Schematic

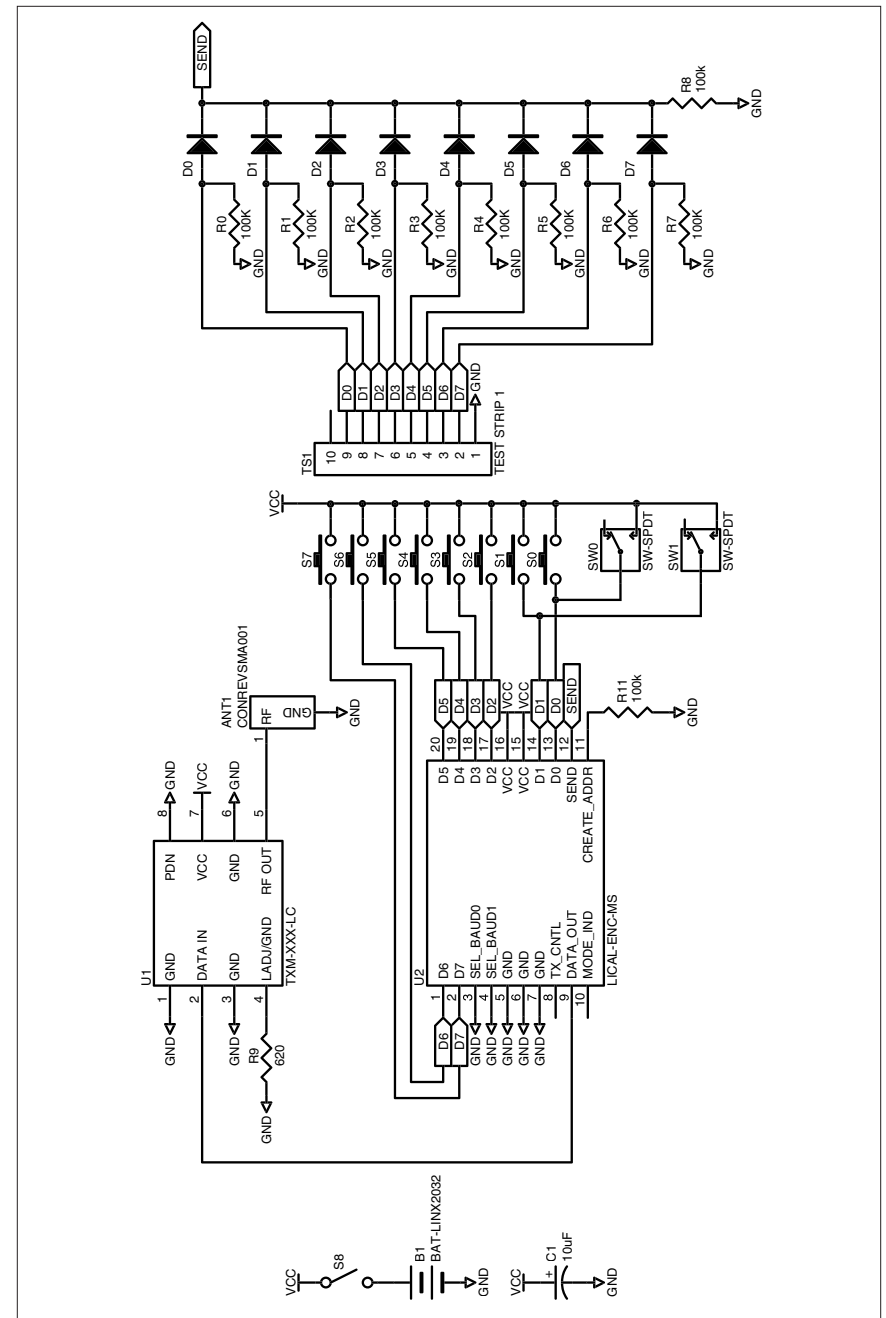

Figure 7: LC Transmitter Evaluation Board Schematic



Linx Technologies
159 Ort Lane
Merlin, OR, US 97532

Phone: +1 541 471 6256
Fax: +1 541 471 6251

www.linxtechnologies.com

Disclaimer

Linx Technologies is continually striving to improve the quality and function of its products. For this reason, we reserve the right to make changes to our products without notice. The information contained in this Data Guide is believed to be accurate as of the time of publication. Specifications are based on representative lot samples. Values may vary from lot-to-lot and are not guaranteed. "Typical" parameters can and do vary over lots and application. Linx Technologies makes no guarantee, warranty, or representation regarding the suitability of any product for use in any specific application. It is the customer's responsibility to verify the suitability of the part for the intended application. **NO LINX PRODUCT IS INTENDED FOR USE IN ANY APPLICATION WHERE THE SAFETY OF LIFE OR PROPERTY IS AT RISK.**

Linx Technologies **DISCLAIMS ALL WARRANTIES OF MERCHANTABILITY AND FITNESS FOR A PARTICULAR PURPOSE. IN NO EVENT SHALL LINX TECHNOLOGIES BE LIABLE FOR ANY OF CUSTOMER'S INCIDENTAL OR CONSEQUENTIAL DAMAGES ARISING IN ANY WAY FROM ANY DEFECTIVE OR NON-CONFORMING PRODUCTS OR FOR ANY OTHER BREACH OF CONTRACT BY LINX TECHNOLOGIES.** The limitations on Linx Technologies' liability are applicable to any and all claims or theories of recovery asserted by Customer, including, without limitation, breach of contract, breach of warranty, strict liability, or negligence. Customer assumes all liability (including, without limitation, liability for injury to person or property, economic loss, or business interruption) for all claims, including claims from third parties, arising from the use of the Products. The Customer will indemnify, defend, protect, and hold harmless Linx Technologies and its officers, employees, subsidiaries, affiliates, distributors, and representatives from and against all claims, damages, actions, suits, proceedings, demands, assessments, adjustments, costs, and expenses incurred by Linx Technologies as a result of or arising from any Products sold by Linx Technologies to Customer. Under no conditions will Linx Technologies be responsible for losses arising from the use or failure of the device in any application, other than the repair, replacement, or refund limited to the original product purchase price. Devices described in this publication may contain proprietary, patented, or copyrighted techniques, components, or materials. Under no circumstances shall any user be conveyed any license or right to the use or ownership of such items.

©2015 Linx Technologies. All rights reserved.

The stylized Linx logo, Wireless Made Simple, WISE, CipherLinx and the stylized CL logo are trademarks of Linx Technologies.



Компания «ЭлектроПласт» предлагает заключение долгосрочных отношений при поставках импортных электронных компонентов на взаимовыгодных условиях!

Наши преимущества:

- Оперативные поставки широкого спектра электронных компонентов отечественного и импортного производства напрямую от производителей и с крупнейших мировых складов;
- Поставка более 17-ти миллионов наименований электронных компонентов;
- Поставка сложных, дефицитных, либо снятых с производства позиций;
- Оперативные сроки поставки под заказ (от 5 рабочих дней);
- Экспресс доставка в любую точку России;
- Техническая поддержка проекта, помощь в подборе аналогов, поставка прототипов;
- Система менеджмента качества сертифицирована по Международному стандарту ISO 9001;
- Лицензия ФСБ на осуществление работ с использованием сведений, составляющих государственную тайну;
- Поставка специализированных компонентов (Xilinx, Altera, Analog Devices, Intersil, Interpoint, Microsemi, Aeroflex, Peregrine, Syfer, Eurofarad, Texas Instrument, Miteq, Cobham, E2V, MA-COM, Hittite, Mini-Circuits, General Dynamics и др.);

Помимо этого, одним из направлений компании «ЭлектроПласт» является направление «Источники питания». Мы предлагаем Вам помощь Конструкторского отдела:

- Подбор оптимального решения, техническое обоснование при выборе компонента;
- Подбор аналогов;
- Консультации по применению компонента;
- Поставка образцов и прототипов;
- Техническая поддержка проекта;
- Защита от снятия компонента с производства.



Как с нами связаться

Телефон: 8 (812) 309 58 32 (многоканальный)

Факс: 8 (812) 320-02-42

Электронная почта: org@eplast1.ru

Адрес: 198099, г. Санкт-Петербург, ул. Калинина, дом 2, корпус 4, литера А.