

Description

The AP3103A is a low startup current, current mode PWM controller with green-mode power-saving operation. The PWM switching frequency at normal operation is externally programmable and is trimmed to a tight range. The dithering of frequency will also improve the EMI feature. When the load decreases, the frequency will reduce and when at a very low load, the IC will enter the 'burst mode' to minimize switching loss.

About 20kHz frequency switching is to avoid the audible noise as well as reducing the standby loss. The skip mode point can be adjusted through the external resistor connected to the current sense resistor.

The AP3103A features a lot of functions such as the Leading-Edge Blanking (LEB) of the current sensing, internal slope compensation and several protection functions including cycle-by-cycle current limit (OCP), VCC Over Voltage Protection (VOVP) and OLP protection.

This IC is available in SOT26 package.

Features

- Very Low Start-up Current
- Current Mode Control
- Non-audible-noise Green-mode Control
- Skip Mode Adjustable
- Internal Slope Compensation
- Soft Start During Startup Process
- Frequency Fold Back for High Average Efficiency
- Secondary Short Winding Protection with FOCP
- Soft Switching for Reducing EMI
- VCC Maintain Mode
- Useful Pin Fault Protection:
 - SENSE Pin Floating
 - RI Pin Short to Ground
 - FB/Opto-coupler Open/Short
- Comprehensive System Protection Feature:
 - VCC Over Voltage Protection (VOVP)
 - Over Load Protection (OLP)
- Mini Size with Packages
- **Totally Lead-Free & Fully RoHS Compliant (Notes 1 & 2)**
- **Halogen and Antimony Free. "Green" Device (Note 3)**

Notes: 1. No purposely added lead. Fully EU Directive 2002/95/EC (RoHS) & 2011/65/EU (RoHS 2) compliant.
 2. See http://www.diodes.com/quality/lead_free.html for more information about Diodes Incorporated's definitions of Halogen- and Antimony-free, "Green" and Lead-free.
 3. Halogen- and Antimony-free "Green" products are defined as those which contain <900ppm bromine, <900ppm chlorine (<1500ppm total Br + Cl) and <1000ppm antimony compounds.

Pin Assignments

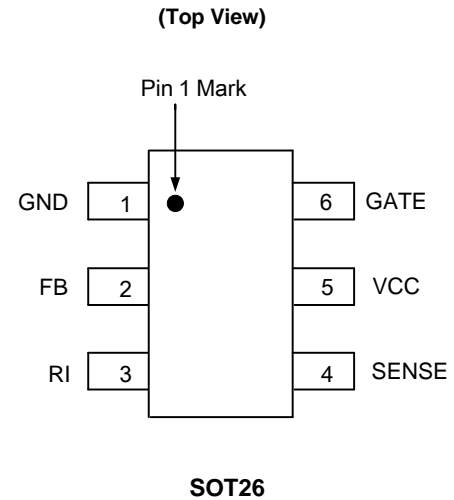

Applications

- Switching AC-DC Adapter/Charger
- ATX/BTX Auxiliary Power
- Set-top Box(STB) Power Supply
- Open Frame Switching Power Supply

Functional Block Diagram

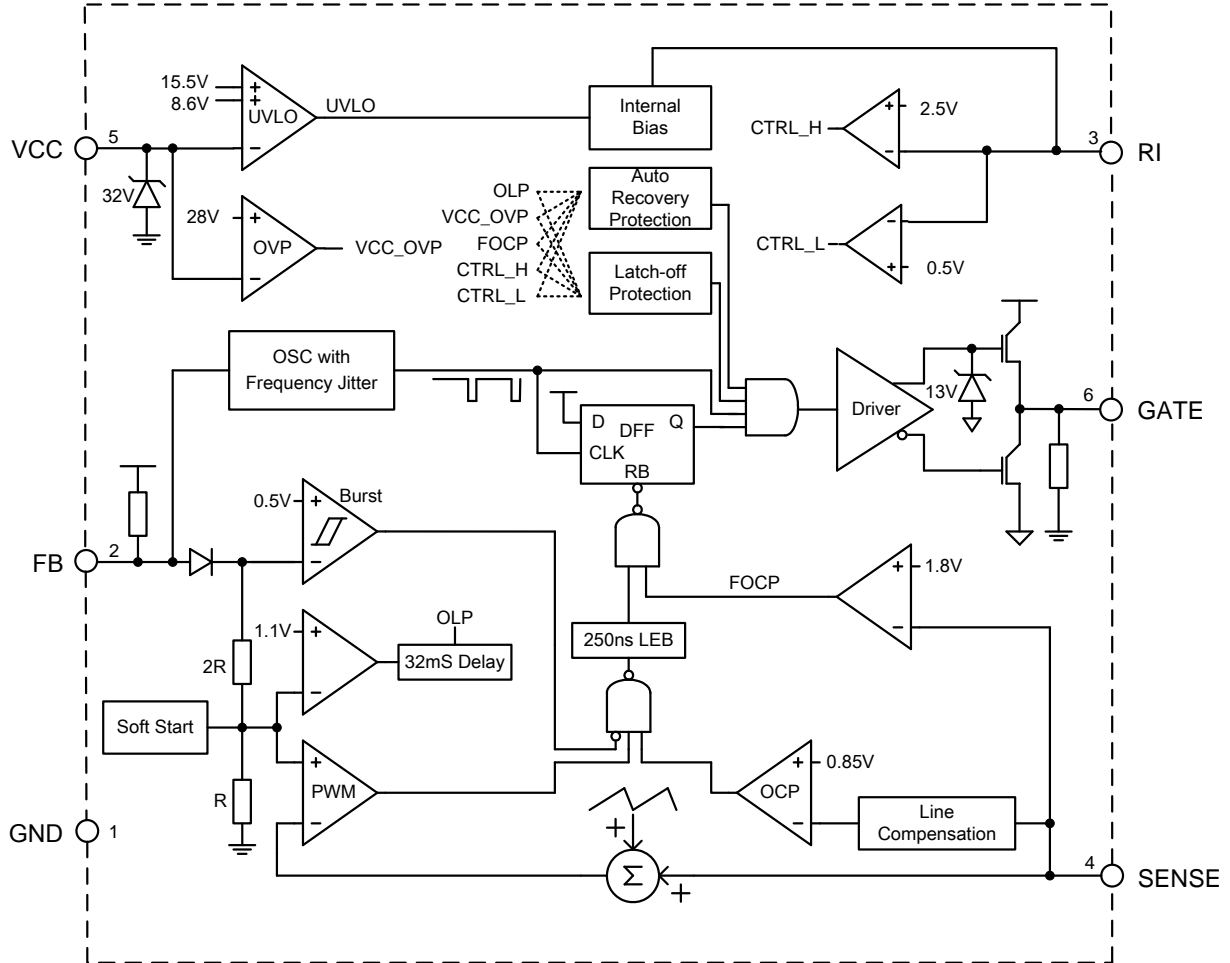

Absolute Maximum Ratings (Note 4)

Symbol	Parameter	Rating	Unit
V_{CC}	Power Supply Voltage	30	V
I_O	Gate Output Current	350	mA
$V_{FB}, V_{SENSE}, V_{RI}$	Input Voltage to FB, SENSE, RI	-0.3 to 7	V
θ_{JA}	Thermal Resistance (Junction to Ambient)	250	°C/W
P_D	Power Dissipation at $T_A < +25\text{ °C}$	500	mW
T_J	Operating Junction Temperature	-40 to +150	°C
T_{STG}	Storage Temperature Range	+150	°C
–	ESD (Human Body Model)	3000	V
–	ESD (Machine Model)	300	V

Note 4: Stresses greater than those listed under "Absolute Maximum Ratings" may cause permanent damage to the device. These are stress ratings only, and functional operation of the device at these or any other conditions beyond those indicated under "Recommended Operating Conditions" is not implied. Exposure to "Absolute Maximum Ratings" for extended periods may affect device reliability.

Recommended Operating Conditions

Symbol	Parameter	Min	Max	Unit
V_{CC}	Supply Voltage	10	25	V

Electrical Characteristics (@T_A = +25°C, V_{CC} = 16V, unless otherwise specified.)

Symbol	Parameter	Conditions	Min	Typ	Max	Unit
Supply Voltage (VCC Pin)						
I _{STARTUP}	Startup Current	–	2	5	25	μA
I _{CC}	Operating Supply Current	V _{FB} =0V, C _L =1nF, R _{RI} =100kΩ	0.5	0.85	1.2	mA
		V _{FB} =3V, C _L =0nF, R _{RI} =100kΩ	0.6	1.2	2.0	
–	UVLO (on)	–	14.5	15.5	16.5	V
–	VCC Maintain	–	9.7	10.2	10.7	V
–	UVLO (off)	–	7.6	8.6	9.6	V
–	VCC OVP	–	27	28.5	30	V
–	VCC Clamp	I _{CC} =5mA	31	34	–	V
PWM Section/Oscillator Section						
–	Maximum Duty Cycle	–	70	75	80	%
–	Oscillation Frequency	R _{RI} =100kΩ	60	65	70	kHz
–	Green Mode Frequency	R _{RI} =100kΩ	20	–	30	kHz
–	Frequency Temperature Stability	-20°C to +125°C (Note 5)	–	–	5	%
–	Frequency Voltage Stability	V _{CC} =12V to 30V	–	–	3	%
–	Frequency Dithering	–	±4	±6	±8	%
Current Sense Section (SENSE Pin)						
V _{CS}	Maximum SENSE Voltage	V _{FB} =3.6V, R _{RI} =100kΩ	0.800	0.850	0.900	V
–	FOCP Voltage	–	1.65	1.8	1.95	V
–	LEB Time of SENSE	R _{RI} =100kΩ	150	250	350	ns
–	Delay to Output (Note 5)	–	–	100	–	ns
–	Soft-start Time	R _{RI} =100kΩ	3	5	8	ms
Feedback Input Section (FB Pin)						
–	The Ratio of Input Voltage to Current Sense Voltage	–	2.5	3	3.5	V/V
–	Input Impedance	–	7	10	13	kΩ
–	Source Current	V _{FB} =0V	-0.75	-0.5	-0.25	mA
–	Green Mode Threshold	–	–	2	–	V
–	Input Voltage for Zero Duty	–	1.3	1.55	1.8	V
Output Section (GATE Pin)						
–	Output Low Level	I _O =20mA, V _{CC} =12V	–	–	1	V
–	Output High Level	I _O =20mA, V _{CC} =12V	8	–	–	V
–	Output Clamping	–	11	13	15	V
–	Rising Time (Note 5)	C _L =1nF, V _{CC} =13V	–	150	250	ns
–	Falling Time (Note 5)	C _L =1nF, V _{CC} =13V	–	50	100	ns
Delay Time Section						
–	Delay of Short Circuit Protection	R _{RI} =100kΩ	22	32	40	ms
–	Delay of Hiccup Protection	VCC OVP	–	25	–	μs

Note 5: Guaranteed by design.

Performance Characteristics

Startup Voltage vs. Ambient Temperature

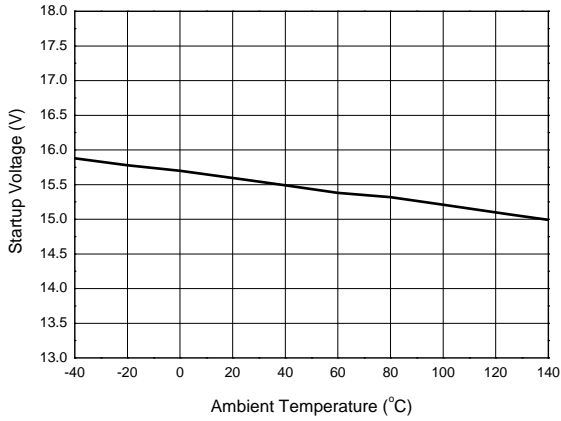

Shutdown Voltage vs. Ambient Temperature

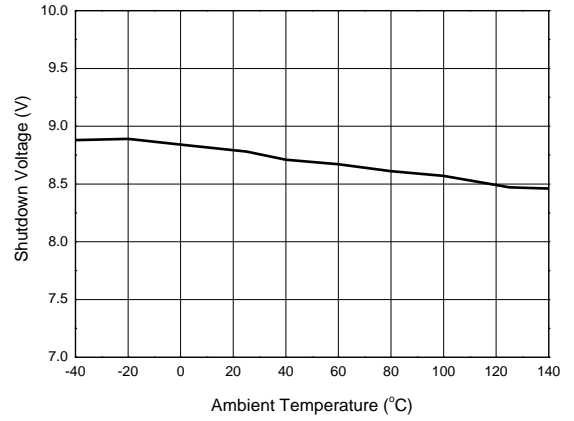

Startup Current vs. Ambient Temperature

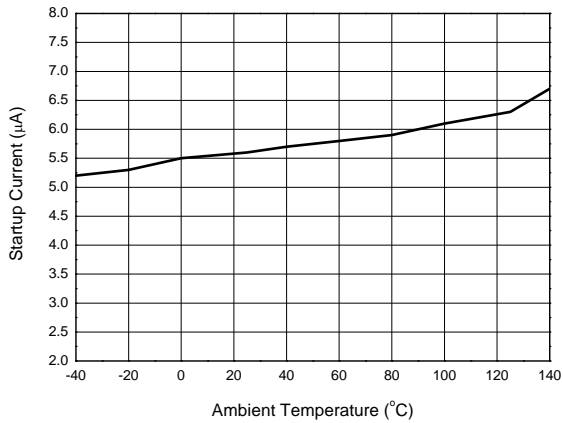

Operating Current vs. Ambient Temperature

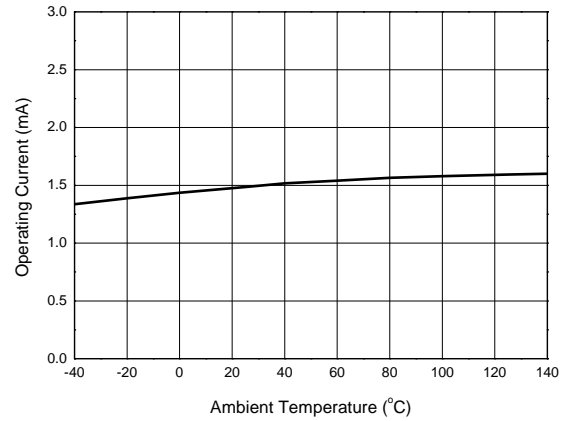

Operation Description

The AP3103A is specifically designed for off-line AC-DC power supply used in LCD monitor, notebook adapter and battery charger applications. It offers a cost effective solution with a versatile protection function.

Start-up Current and UVLO

The start-up current of AP3103A is optimized to realize ultra low current (5µA typical) so that VCC capacitor can be charged more quickly. The direct benefit of low start-up current is the availability of using large start-up resistor, which minimizes the resistor power loss for high voltage AC input.

An UVLO comparator is included in AP3103A to detect the voltage on VCC pin. It ensures that AP3103A can draw adequate energy from hold-up capacitor during power-on. The turn-on threshold is 15.5V and the turn-off threshold is 8.6V.

Oscillator

The oscillation frequency is programmed by the value of resistor R1, connected from pin RI to ground. The resistor will make a constant current source to determine the oscillation frequency by charging and discharging an internal capacitor. Normally, RI pin should not be placed where exists too much noise, as the disturbance may make the IC work abnormally.

The oscillation frequency can be expressed as:

$$f \approx \frac{6500}{R1(k\Omega)} \text{ (kHz)}$$

The recommended oscillation frequency is 50Hz to 100kHz from the EMI consideration.

Current Sense Comparator and PWM Latch

The AP3103A operates as a current mode controller, the output switch conduction is initiated by every oscillator cycle and is terminated when the peak inductor current reaches the threshold level established by the FB pin. The inductor current signal is converted to a voltage signal by inserting a reference sense resistor R_S . The inductor current under normal operating conditions is controlled by the voltage at FB pin. The relation between peak inductor current (I_{PK}) and V_{FB} is:

$$I_{PK} = (V_{FB} - 0.8) / 3R_S$$

Moreover, FOCP with 1.8V threshold is only about 100ns delay, which can avoid some catastrophic damages such as secondary rectifier short test. Few drive cycles can alleviate the destruction range and get better protection.

Leading-edge Blanking

A narrow spike on the leading edge of the current waveform can usually be observed when the power MOSFET is turned on. A 250ns leading-edge blank is built-in to prevent the false-triggering caused by the turn-on spike. During this period, the current limit comparator is disabled and the gate driver cannot be switched off.

At the time of turning on the MOSFET, a negative undershoot (maybe larger than -0.3V) can occur on the SENSE pin. So it is strongly recommended to add a small RC filter or at least connect a resistor "R" on this pin to protect the IC (Shown as Figure 1).

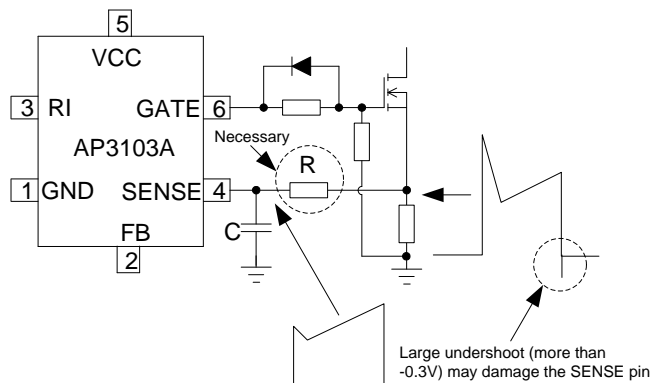

Figure 1

Operation Description

Built-in Slope Compensation

It is well known that a continuous current mode SMPS may become unstable when the duty cycle exceeds 50%. The built-in slope compensation can improve the stability, so there is no need for design engineer to spend much time on that.

FB Pin and Short Circuit Protection

This pin is normally connected to the opto-coupler and always paralleled with a capacitor for loop compensation. When the voltage at this pin is greater than 4.2V and lasts for about 32ms, the IC will enter the protection mode. For AP3103A, the system will enter hiccup mode to wait the V_{CC} decreasing to low UVLO level, then the IC will try to restart until the failure removed. And when this voltage is less than 1.55V, the IC will stop the drive pulse immediately. Therefore, this feature can be used for short circuit protection, which makes the system immune from damage. Normally, output short makes the V_{FB} value to the maximum because the opto-coupler is cut off.

V_{CC} Maintain Mode

During light load or step load, V_{FB} will drop and be lower than 1.55V, thus the PWM drive signal will be stopped, and there is no more new energy transferred due to no switching. Therefore, the IC supply voltage may reduce to the shutdown threshold voltage and system may enter the unexpected restart mode. To avoid this, the AP3103A hold a so-called V_{CC} maintain mode which can supply energy to V_{CC} .

When V_{CC} decreases to a setting threshold, the V_{CC} maintain comparator will output some drive signal to make the system switch and provide a proper energy to V_{CC} pin. The V_{CC} maintain function will cooperate the PWM and burst mode loop which can make the output voltage variation be within the regulation. This mode is very useful for reducing startup resistor loss and achieving a better standby performance with a low value V_{CC} capacitor. The V_{CC} is not easy to touch the shutdown threshold during the startup process and step load. This will also simplify the system design. The normal V_{CC} voltage is suggested to be designed a little higher than V_{CC} maintain threshold thus can achieve the best balance between the standby and step load performance.

System Protection and Pin Fault Protection

The AP3103A provides versatile system and pin fault protections. The OCP comparator realizes the cycle-by-cycle current limiting (OCP). In universal input line voltage, the IC realizes the constant over load protection (OLP). V_{CC} over voltage protection can be applied as the primary OVP or opto-coupler broken protection. The AP3103A also has pin fault connection protection including floating and short connection. The floating pin protections include the SENSE, FB, etc. The short pin protection includes the RI pin short protection. When these pins are floated or RI pin is shorted to ground, PWM switching will be disabled, thus protecting the power system.

Ordering Information

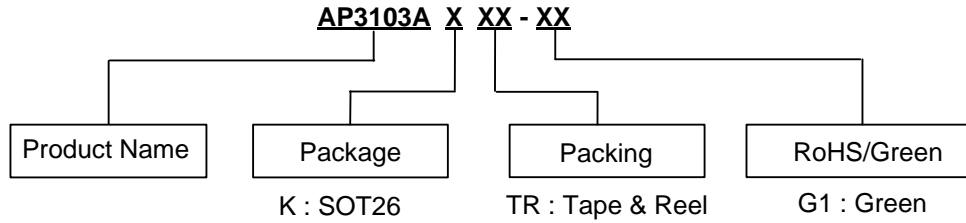

Package	Part Number	Marking ID	Packing
SOT26	AP3103AKTR-G1	GHL	3000/Tape & Reel

Protection Functions

Product Version	VOVP	OLP& FOCP
AP3103A	Auto-Recoverable	Auto-Recoverable

Marking Information

(Top View)

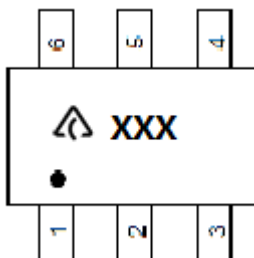

 : Logo
 XXX: Marking ID (See Ordering Information)

Package Outline Dimensions (All dimensions in mm(inch).)

(1) Package Type: SOT26

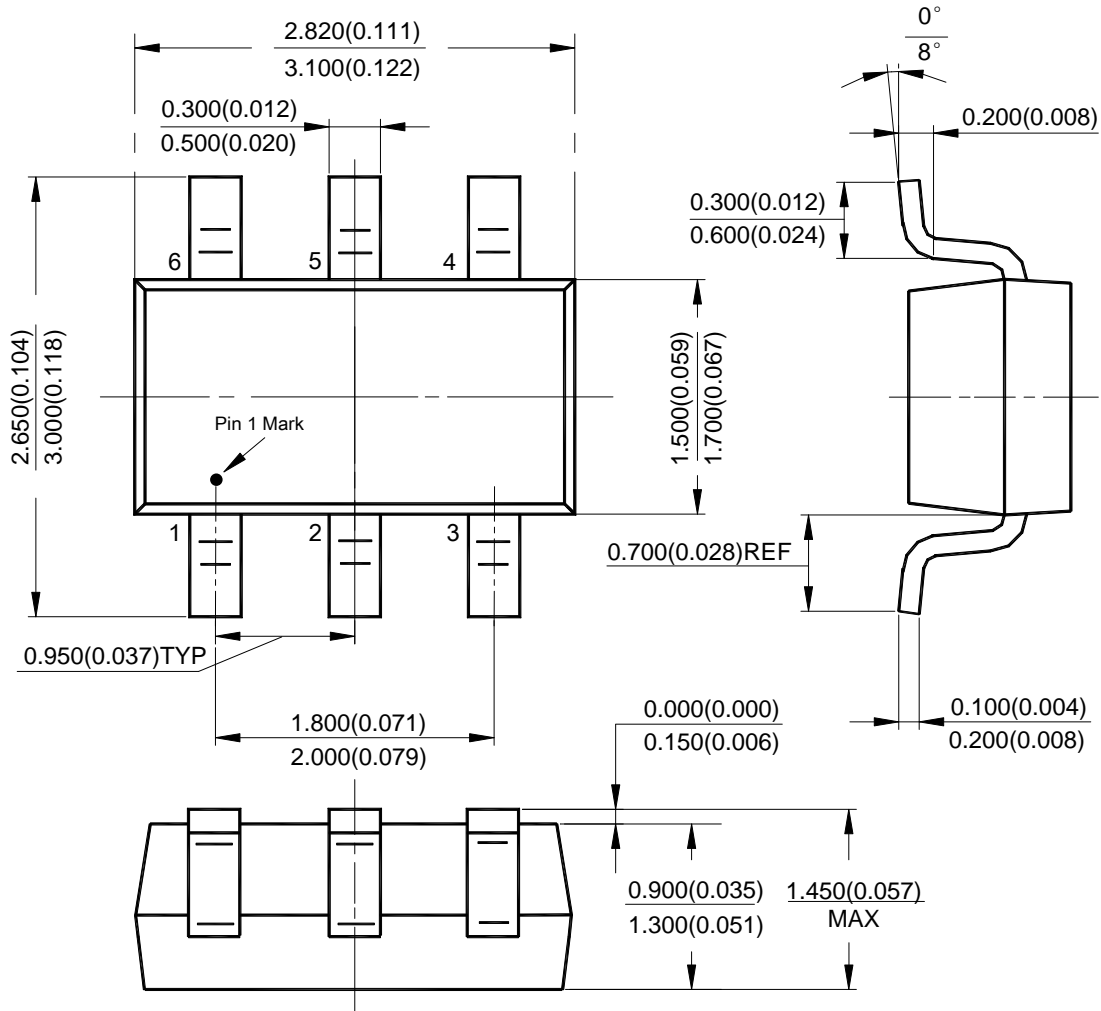

Suggested Pad Layout

(1) Package Type: SOT26

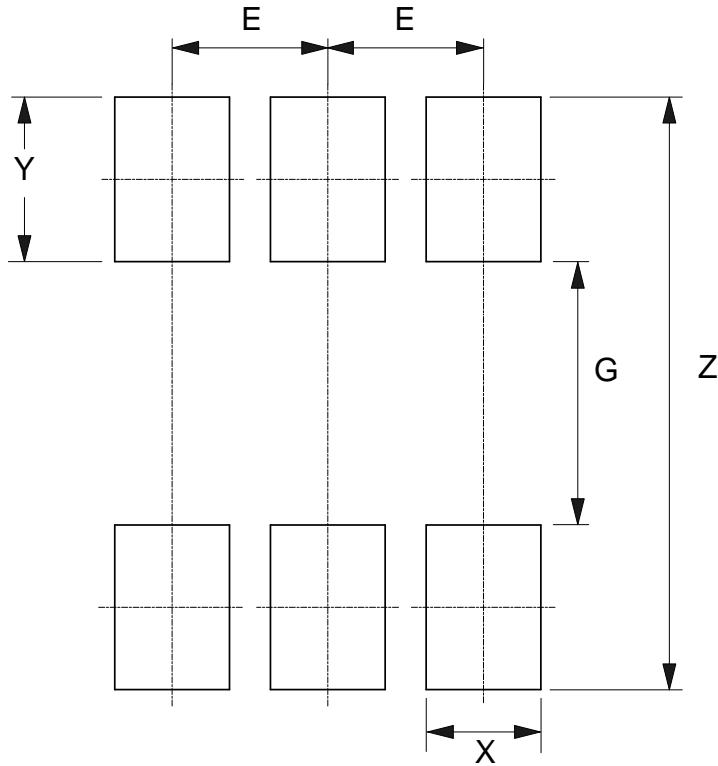

Dimensions	Z (mm)/(inch)	G (mm)/(inch)	X (mm)/(inch)	Y (mm)/(inch)	E (mm)/(inch)
Value	3.600/0.142	1.600/0.063	0.700/0.028	1.000/0.039	0.950/0.037

IMPORTANT NOTICE

DIODES INCORPORATED MAKES NO WARRANTY OF ANY KIND, EXPRESS OR IMPLIED, WITH REGARDS TO THIS DOCUMENT, INCLUDING, BUT NOT LIMITED TO, THE IMPLIED WARRANTIES OF MERCHANTABILITY AND FITNESS FOR A PARTICULAR PURPOSE (AND THEIR EQUIVALENTS UNDER THE LAWS OF ANY JURISDICTION).

Diodes Incorporated and its subsidiaries reserve the right to make modifications, enhancements, improvements, corrections or other changes without further notice to this document and any product described herein. Diodes Incorporated does not assume any liability arising out of the application or use of this document or any product described herein; neither does Diodes Incorporated convey any license under its patent or trademark rights, nor the rights of others. Any Customer or user of this document or products described herein in such applications shall assume all risks of such use and will agree to hold Diodes Incorporated and all the companies whose products are represented on Diodes Incorporated website, harmless against all damages.

Diodes Incorporated does not warrant or accept any liability whatsoever in respect of any products purchased through unauthorized sales channel. Should Customers purchase or use Diodes Incorporated products for any unintended or unauthorized application, Customers shall indemnify and hold Diodes Incorporated and its representatives harmless against all claims, damages, expenses, and attorney fees arising out of, directly or indirectly, any claim of personal injury or death associated with such unintended or unauthorized application.

Products described herein may be covered by one or more United States, international or foreign patents pending. Product names and markings noted herein may also be covered by one or more United States, international or foreign trademarks.

This document is written in English but may be translated into multiple languages for reference. Only the English version of this document is the final and determinative format released by Diodes Incorporated.

LIFE SUPPORT

Diodes Incorporated products are specifically not authorized for use as critical components in life support devices or systems without the express written approval of the Chief Executive Officer of Diodes Incorporated. As used herein:

A. Life support devices or systems are devices or systems which:

1. are intended to implant into the body, or
2. support or sustain life and whose failure to perform when properly used in accordance with instructions for use provided in the labeling can be reasonably expected to result in significant injury to the user.

B. A critical component is any component in a life support device or system whose failure to perform can be reasonably expected to cause the failure of the life support device or to affect its safety or effectiveness.

Customers represent that they have all necessary expertise in the safety and regulatory ramifications of their life support devices or systems, and acknowledge and agree that they are solely responsible for all legal, regulatory and safety-related requirements concerning their products and any use of Diodes Incorporated products in such safety-critical, life support devices or systems, notwithstanding any devices- or systems-related information or support that may be provided by Diodes Incorporated. Further, Customers must fully indemnify Diodes Incorporated and its representatives against any damages arising out of the use of Diodes Incorporated products in such safety-critical, life support devices or systems.

Copyright © 2014, Diodes Incorporated

www.diodes.com



Компания «ЭлектроПласт» предлагает заключение долгосрочных отношений при поставках импортных электронных компонентов на взаимовыгодных условиях!

Наши преимущества:

- Оперативные поставки широкого спектра электронных компонентов отечественного и импортного производства напрямую от производителей и с крупнейших мировых складов;
- Поставка более 17-ти миллионов наименований электронных компонентов;
- Поставка сложных, дефицитных, либо снятых с производства позиций;
- Оперативные сроки поставки под заказ (от 5 рабочих дней);
- Экспресс доставка в любую точку России;
- Техническая поддержка проекта, помощь в подборе аналогов, поставка прототипов;
- Система менеджмента качества сертифицирована по Международному стандарту ISO 9001;
- Лицензия ФСБ на осуществление работ с использованием сведений, составляющих государственную тайну;
- Поставка специализированных компонентов (Xilinx, Altera, Analog Devices, Intersil, Interpoint, Microsemi, Aeroflex, Peregrine, Syfer, Eurofarad, Texas Instrument, Miteq, Cobham, E2V, MA-COM, Hittite, Mini-Circuits, General Dynamics и др.);

Помимо этого, одним из направлений компании «ЭлектроПласт» является направление «Источники питания». Мы предлагаем Вам помощь Конструкторского отдела:

- Подбор оптимального решения, техническое обоснование при выборе компонента;
- Подбор аналогов;
- Консультации по применению компонента;
- Поставка образцов и прототипов;
- Техническая поддержка проекта;
- Защита от снятия компонента с производства.



Как с нами связаться

Телефон: 8 (812) 309 58 32 (многоканальный)

Факс: 8 (812) 320-02-42

Электронная почта: org@eplast1.ru

Адрес: 198099, г. Санкт-Петербург, ул. Калинина, дом 2, корпус 4, литера А.