



SANYO Semiconductors

DATA SHEET

An ON Semiconductor Company

LV8860V

Bi-CMOS IC

Fan Motor Driver

Single-Phase Full-Wave Driver

Overview

LV8860V is a driver IC used for single-phase fan motor. High-efficiency and low-noise are realized by reducing reactive power using Silent PWM.

The operating range of LV8860V is wide. LV8860V also corresponds to 24V. Therefore, it is optimal for office automation equipment and factory automation equipment.

Functions

- Single-phase full wave operation by Silent PWM drive.
- Speed is controllable by PWM input.
- Hall bias output pin.
- Integrated Quick Start Circuit.
- FG (rotation detection) / RD (lock detection) output pin (open drain output)
- Integrated current limiter circuit (limit at $I_O=450\text{mA}$ with $R_f=0.5\Omega$ connection, limit value is determined based on R_f .)
- Integrated lock protector circuit and automatic recovery circuit.
- Integrated thermal shut-down (TSD) circuit.

Specifications

Maximum Ratings at $T_a = 25^\circ\text{C}$

Parameter	Symbol	Conditions	Ratings	Unit
Maximum supply voltage	$V_{CC \text{ max}}$		36	V
OUT pin output current	$I_{OUT \text{ max}}$		0.7	A
Output withstand	$V_{OUT \text{ max}}$		36	V
RD/FG output pin withstand	$V_{RD/FG \text{ max}}$		36	V
RD/FG output maximum current	$I_{RD/FG \text{ max}}$		10	mA
RGL output maximum current	$I_{RGL \text{ max}}$		5	mA
HB output maximum current	$I_{HB \text{ max}}$		10	mA

Continued on next page.

■ Any and all SANYO Semiconductor Co.,Ltd. products described or contained herein are, with regard to "standard application", intended for the use as general electronics equipment. The products mentioned herein shall not be intended for use for any "special application" (medical equipment whose purpose is to sustain life, aerospace instrument, nuclear control device, burning appliances, transportation machine, traffic signal system, safety equipment etc.) that shall require extremely high level of reliability and can directly threaten human lives in case of failure or malfunction of the product or may cause harm to human bodies, nor shall they grant any guarantee thereof. If you should intend to use our products for new introduction or other application different from current conditions on the usage of automotive device, communication device, office equipment, industrial equipment etc. , please consult with us about usage condition (temperature, operation time etc.) prior to the intended use. If there is no consultation or inquiry before the intended use, our customer shall be solely responsible for the use.

■ Specifications of any and all SANYO Semiconductor Co.,Ltd. products described or contained herein stipulate the performance, characteristics, and functions of the described products in the independent state, and are not guarantees of the performance, characteristics, and functions of the described products as mounted in the customer's products or equipment. To verify symptoms and states that cannot be evaluated in an independent device, the customer should always evaluate and test devices mounted in the customer's products or equipment.

SANYO Semiconductor Co., Ltd.

<http://semicon.sanyo.com/en/network>

LV8860V

Continued from preceding page.

Parameter	Symbol	Conditions	Ratings	Unit
PWM input pin withstand	V _{PWM} max		6	V
Allowable power dissipation	P _d max	* On a specified board	0.8	W
Operating temperature	T _{opr}		-40 to +95	°C
Storage temperature	T _{stg}		-55 to +150	°C

*Specified board: 114.3mm × 76.1mm × 1.6mm fiberglass epoxy printed circuit board

Caution 1) Absolute maximum ratings represent the value which cannot be exceeded for any length of time.

Caution 2) Even when the device is used within the range of absolute maximum ratings, as a result of continuous usage under high temperature, high current, high voltage, or drastic temperature change, the reliability of the IC may be degraded. Please contact us for the further details.

Recommended Operating Conditions at Ta = 25°C

Parameter	Symbol	Conditions	Ratings	Unit
Operating supply voltage range	V _{CC} op1	Recommended supply voltage range	7 to 34	V
	V _{CC} op2	Boot guarantee supply voltage range	6 to 34	V
Hall input common phase input voltage range	V _{ICM}		0.3 to VRGL-2.0	V
SSW pin input voltage range	SSW		1.0 to 3.0	V
Input PWM frequency range	PWMF		20 to 50	kHz

Electrical Characteristics at Ta = 25°C, V_{CC} = 24V

Parameter	Symbol	Conditions	Ratings			Unit
			min	typ	max	
Circuit consumption current	I _{CC}	Active		2.2	3.5	mA
	I _{CC} ^o	Stand-by		1.7	2.7	mA
RGL pin output voltage	VRGL		4.7	5.0	5.3	V
RGH pin output voltage	VRGH		V _{CC} -4.3	V _{CC} -4.8	V _{CC} -5.3	V
HB pin output voltage	VHB	I _{HB} =5mA	1.16	1.25	1.28	V
Output ON resistance	R _{on}	I _O =0.3A, upper and lower ON resistance		1.4	2.0	Ω
Hall input bias current	I _{HIN}				1.0	μA
Current limiter	V _{RF}		200	225	250	mV
PWM pin input Low level	V _{PWML}		0		1.0	V
PWM pin input High level	V _{PWMH}		2.5		VRGL	V
PWM input minimum pulse width	T _{PWM}			2		μs
RD/FG output pin Low voltage	V _{RD/FG}	I _{RD/FG} =3mA		0.22	0.3	V
FG output leakage current	I _{RD/FG}	V _{RD/FG} =24V			10	μA
FG comparator hysteresis width	ΔV _{HYS}	including offset	±5	±12	±18	mV
Output ON time in Lock-detection	T _{ACT}		0.74	0.95	1.16	sec
Output OFF time in Lock-detection	T _{DET}		7.0	9.0	11.0	sec
Output ON/OFF ratio in Lock-detection	T _{RTO}	T _{RTO} =T _{DET} /T _{ACT}	7.5	9.0	11.0	
Thermal shutdown operating temperature	T _{SD}	* Design guarantee		180		°C
Thermal shutdown hysteresis width	ΔT _{SD}	* Design guarantee		40		°C

* Design guarantee: Signifies target value in design. These parameters are not tested in an independent IC.

Truth table

Operating state	IN1	IN2	PWM	OUT1	OUT2	FG	RD
Rotation – drive mode	H	L	H	H	L	L	L
	L	H		L	H	OFF	L
Rotation – regeneration mode	H	L	L	L	L	L	L
	L	H		L	L	OFF	L
Stand-by mode	-	-	L	L	OFF	OFF	L
Lock protector	H	L	-	OFF	L	L	OFF
	L	H		L	OFF	OFF	OFF

LV8860V

Block Diagram

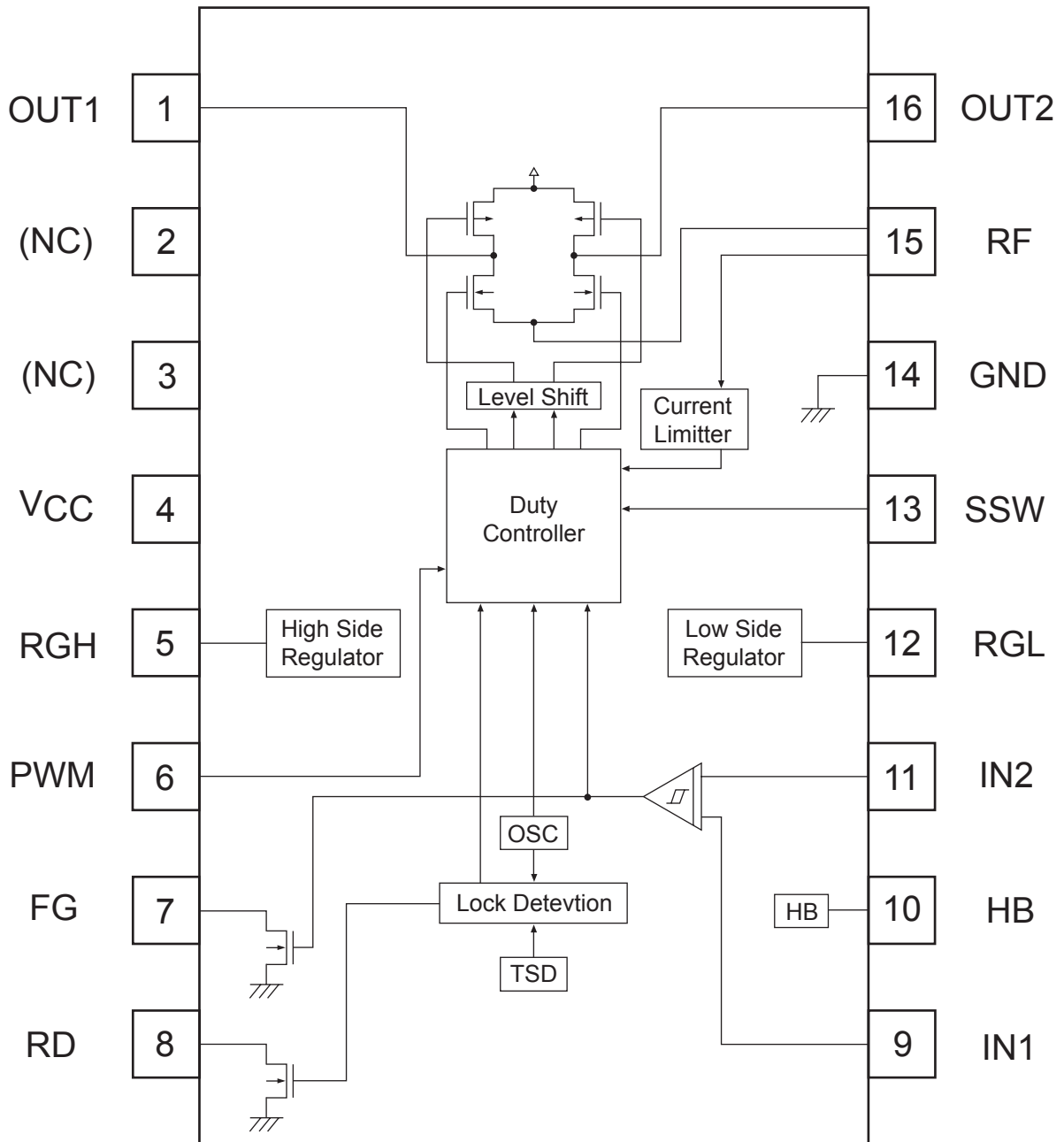

LV8860V

PIN function

*On circuit board, ∇ means V_{CC} , \uparrow means RGL.

NO.	Pin name	Function	Equivalent circuit
1	OUT1	Output pin for motor driver	
16	OUT2		
2	NC	No connect pin	
3	NC	No connect pin	
4	V_{CC}	Power supply pin	
5	RGH	Regulator voltage output pin for the upper output Tr driver	
6	PWM	Input pin for PWM control * OPEN: pull up to High * When input is High → output is High When input is Low → output is Low	
7	FG	FG (rotation detection) pulse output pin	
8	RD	RD (lock detection) signal output pin * During rotation → output is Low During lock → output is High	
9	IN1	Hall input + pin	
11	IN2	Hall input - pin	
10	HB	Hall bias output pin	

Continued on next page.

LV8860V

Continued from preceding page.

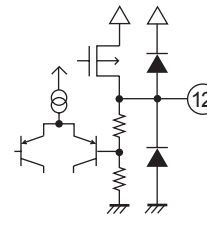
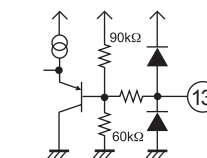
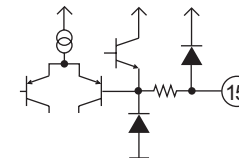
NO.	Pin name	Function	Equivalent circuit
12	RGL	Regulator voltage output pin for internal circuit and lower output Tr driver	
13	SSW	Voltage input pin for control between soft switches * OPEN: pin voltage is 2V * Soft switch zone is changed by connecting a resistance to RGL or GND to adjust pin voltage.	
14	GND	Ground pin	
15	RF	Resistive connection pin for current limiter	

Sample Application Circuit

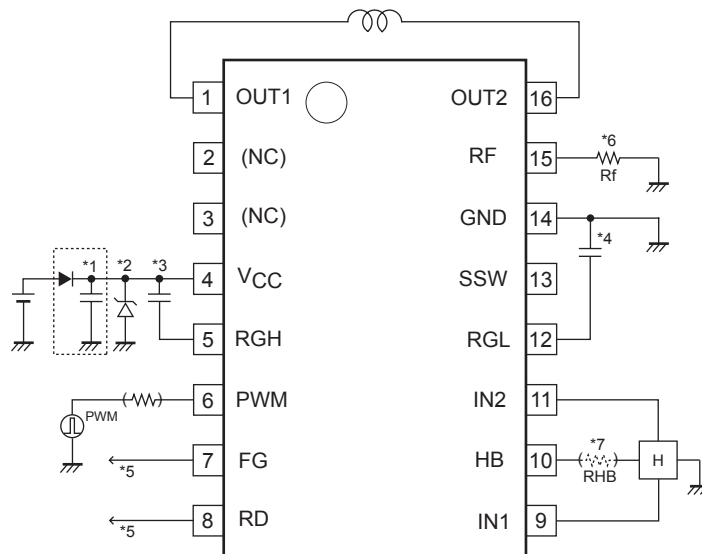

- *1 When diode D_i is used to prevent destruction of IC from reverse connection, make sure to implement capacitor C_r to secure regenerative current route.
- *2 If kickback at a phase change is greater, insert zener diode between GND and V_{CC} or implement the larger capacitor between GND and V_{CC} mentioned in *1
- *3 Make sure to implement enough capacitance $0.1\mu\text{F}$ or greater between RGH pin and V_{CC} pin for stable performance.
- *4 Make sure to implement enough capacitance $0.1\mu\text{F}$ or greater between RGL pin and GND pin for stable performance.
- *5 FG pin and RD pin are open drain output. Keep the pins open when unused.
- *6 The current limiter is activated when the current detection resistor voltage exceeds 225mV between RF and GND. Where $R_f=0.5\Omega$, current limiter is activated at $I_O=450\text{mA}$. Setting is made using R_f resistance.
- *7 Hall element outputs stable hall signal with good temperature characteristic when it is biased with constant voltage from HB pin. If you wish to alleviate heating of IC, do not use HB pin. When you do not use this Pin (Pin HB), pull down with resistor of around $10\text{k}\Omega$ (recommended).

Adjustment of a direction between soft switches

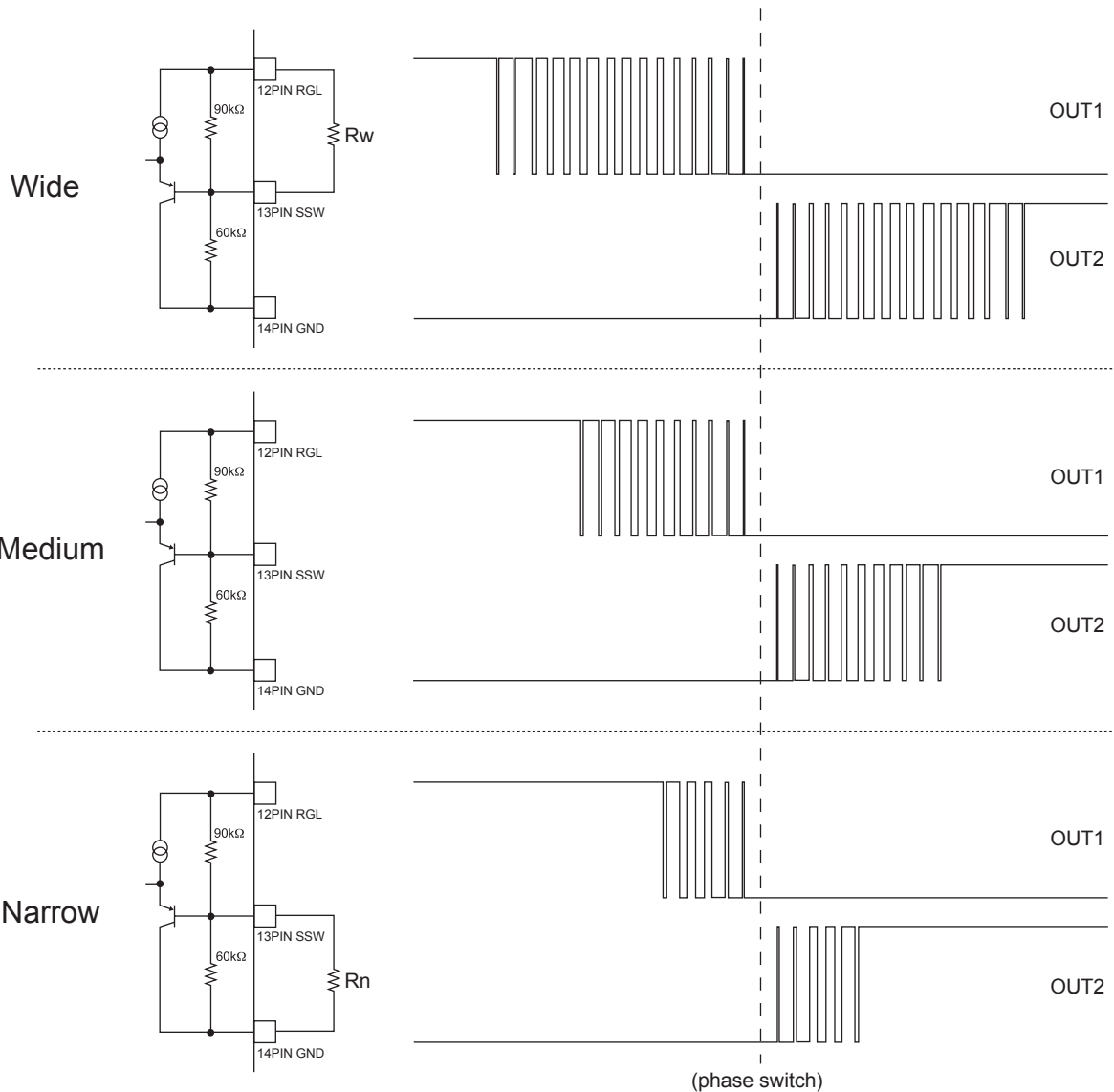

LV8860V realizes high efficiency and low noise by controlling reactive power using soft switch before and after phase switch by variable PWM-duty.

The width of soft switch before and after switching is controlled by SSW pin voltage. Therefore, it is adjustable by connecting an external resistance to SSW. Adjustment voltage range is between 1V and 3V.

* Without adjustment (SSW is open * this is a reference width of soft switch)

... with IC's internal resistance: $V_{SSW} = 5 \times 60k / (90k + 60k) = 2V$

* To widen width of soft switch (connect R_w (resistance) between RGL and SSW.)

... $V_{SSW} = 5 \times 60k / (60k + 1 / (1/R_w + 1/90k))$

ex.) Connect $R_w = 75k\Omega$

$V_{SSW} = 5 \times 60k / (60k + 1 / (1/75k + 1/90k)) = 2.97V$

* To narrow soft switch width (connect R_n (resistance) between SSW and GND.)

... $V_{SSW} = 5 \times ((1 / (1/R_n + 1/60k)) / (90k + 1 / (1/R_n + 1/60k)))$

ex.) Connect $R_n = 39k\Omega$

$V_{SSW} = 5 \times ((1/(1/39k + 1/60k)) / (90k + 1 / (1/39k + 1/60k))) = 1.04V$

Setting value of input signal amplitude

The width of soft switch in LV8860V is controlled by input signal, IN1/IN2. The difference of input voltage (V_{INp-p}) that creates width of soft switch is adjustable by SSW voltage (VSSW) of an external pin. The range of SSW input voltage is between 1V and 3V.

Difference of input signal amplitude in VSSW range:

- When VSSW = 1V (min), $V_{INp-p} = 30mV$ → make sure to input Hall signal with amplitude difference greater than 30mV.
- When VSSW = 2V (open), $V_{INp-p} = 90mV$ → make sure to input Hall signal with amplitude difference greater than 90mV.
- When VSSW = 3V (max), $V_{INp-p} = 150mV$ → make sure to input Hall signal with amplitude difference greater than 150mV.

* When input signal amplitude is greater than V_{INp-p} (as shown in Fig. A below).

Width of soft switch is defined as shown in Fig. A

* When input signal amplitude is less than V_{INp-p} (as shown in Fig. B below).

Since input signal is within the range of V_{INp-p} in all rotations, the entire zone is the soft switch zone.

Consequently, IC does not operate properly.

For such reason, make sure to input Hall signal with enough amplitude difference to SSW setting value so that IC operates properly.

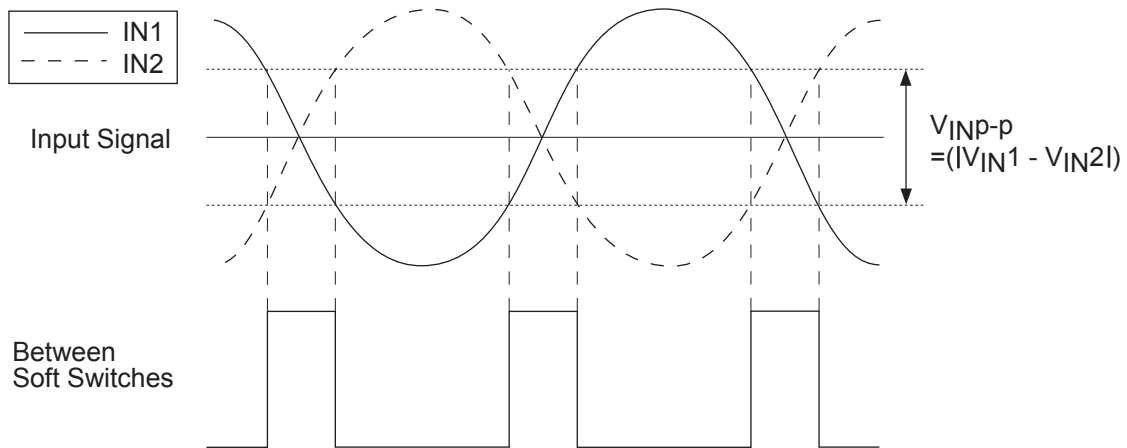

Fig.A

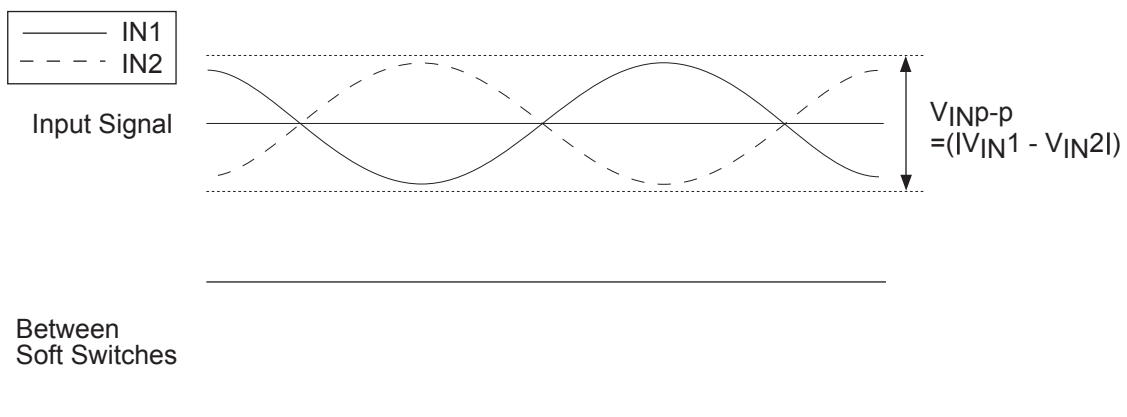
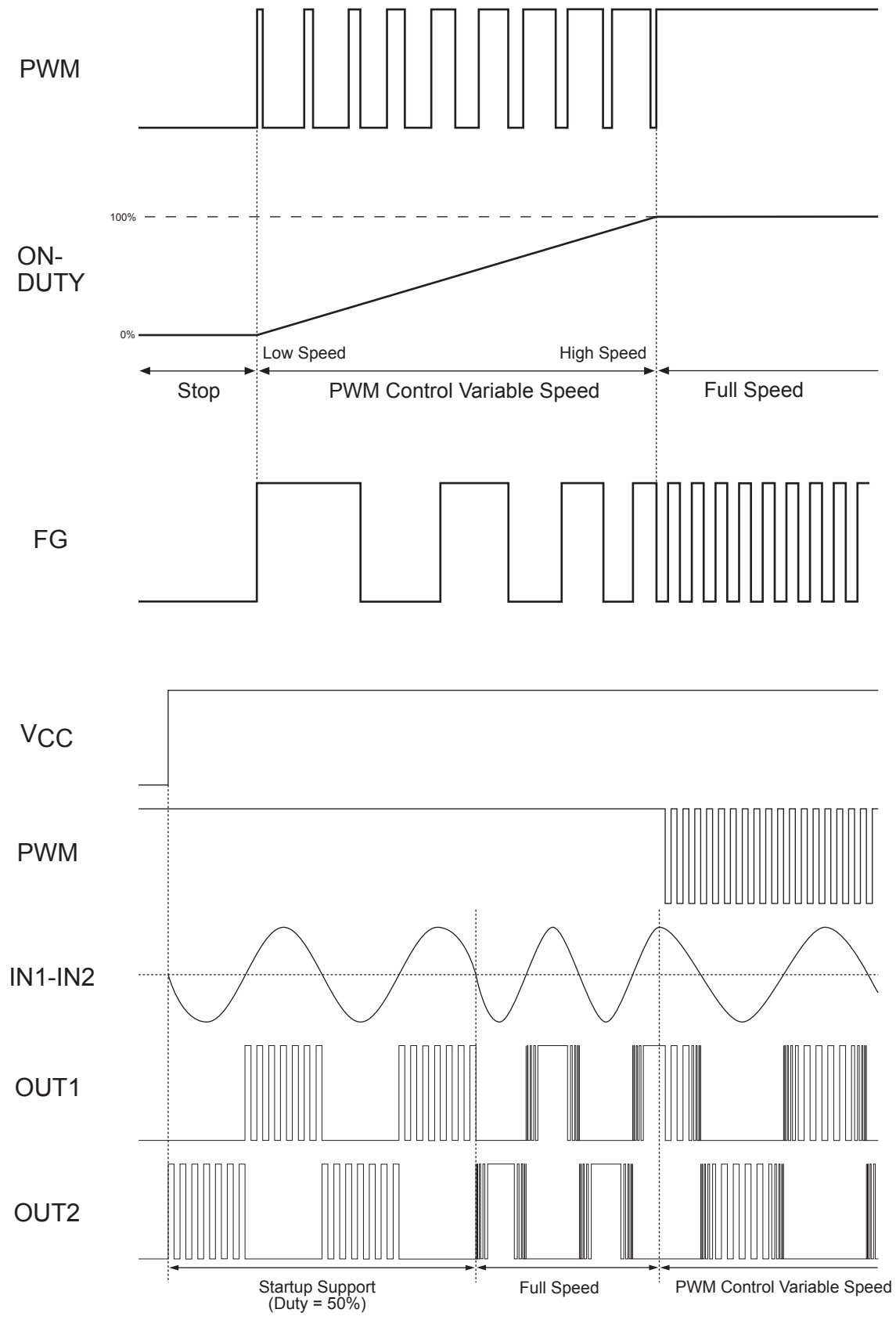

Fig.B

Description of operation

- PWM speed control waveform



• Lock protection operation waveform

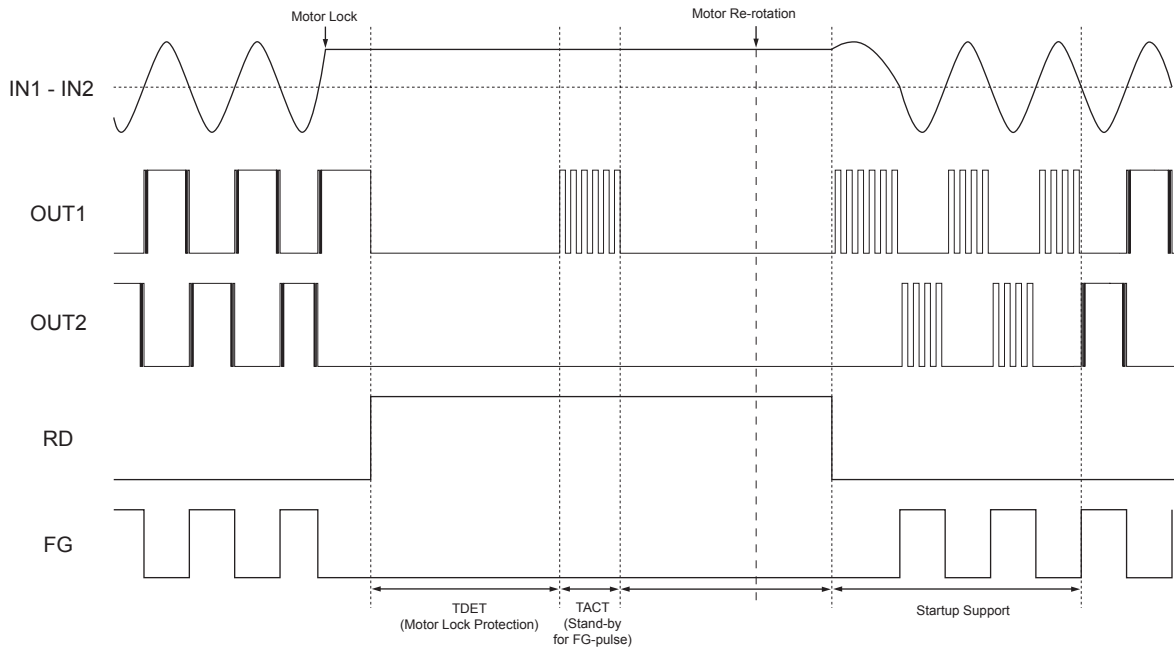

• Stand-by mode operation waveform

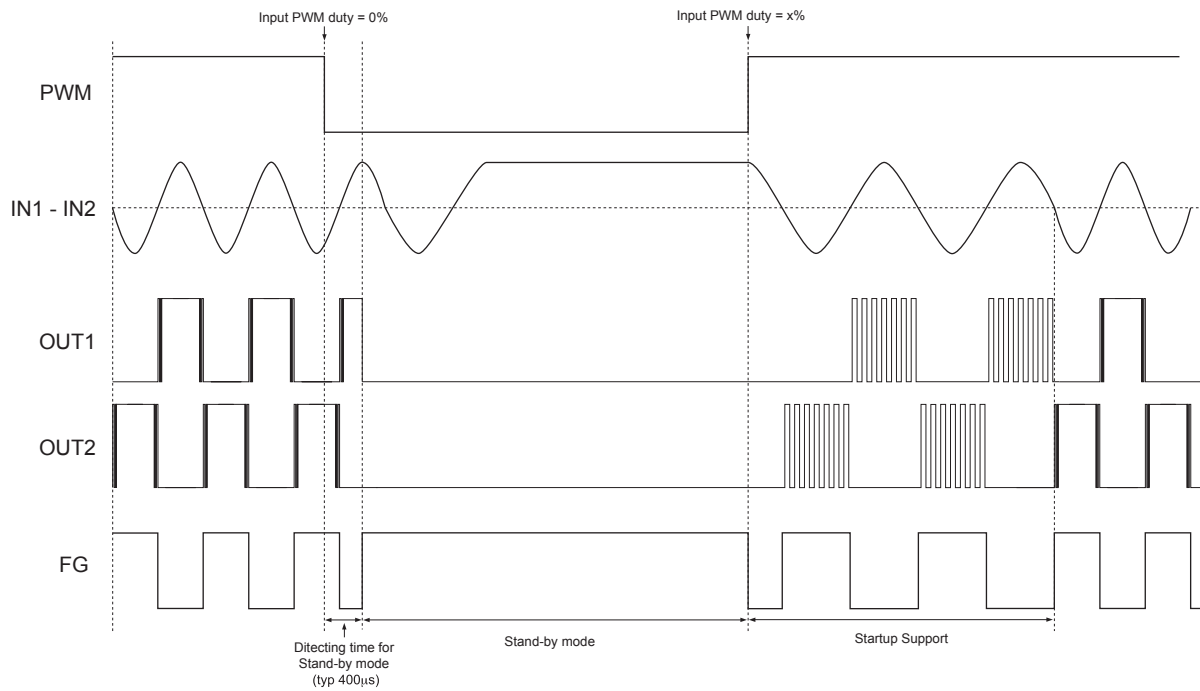

- SANYO Semiconductor Co.,Ltd. assumes no responsibility for equipment failures that result from using products at values that exceed, even momentarily, rated values (such as maximum ratings, operating condition ranges, or other parameters) listed in products specifications of any and all SANYO Semiconductor Co.,Ltd. products described or contained herein.
- SANYO Semiconductor Co.,Ltd. strives to supply high-quality high-reliability products, however, any and all semiconductor products fail or malfunction with some probability. It is possible that these probabilistic failures or malfunction could give rise to accidents or events that could endanger human lives, trouble that could give rise to smoke or fire, or accidents that could cause damage to other property. When designing equipment, adopt safety measures so that these kinds of accidents or events cannot occur. Such measures include but are not limited to protective circuits and error prevention circuits for safe design, redundant design, and structural design.
- In the event that any or all SANYO Semiconductor Co.,Ltd. products described or contained herein are controlled under any of applicable local export control laws and regulations, such products may require the export license from the authorities concerned in accordance with the above law.
- No part of this publication may be reproduced or transmitted in any form or by any means, electronic or mechanical, including photocopying and recording, or any information storage or retrieval system, or otherwise, without the prior written consent of SANYO Semiconductor Co.,Ltd.
- Any and all information described or contained herein are subject to change without notice due to product/technology improvement, etc. When designing equipment, refer to the "Delivery Specification" for the SANYO Semiconductor Co.,Ltd. product that you intend to use.
- Upon using the technical information or products described herein, neither warranty nor license shall be granted with regard to intellectual property rights or any other rights of SANYO Semiconductor Co.,Ltd. or any third party. SANYO Semiconductor Co.,Ltd. shall not be liable for any claim or suits with regard to a third party's intellectual property rights which has resulted from the use of the technical information and products mentioned above.

This catalog provides information as of November, 2011. Specifications and information herein are subject to change without notice.



Компания «ЭлектроПласт» предлагает заключение долгосрочных отношений при поставках импортных электронных компонентов на взаимовыгодных условиях!

Наши преимущества:

- Оперативные поставки широкого спектра электронных компонентов отечественного и импортного производства напрямую от производителей и с крупнейших мировых складов;
- Поставка более 17-ти миллионов наименований электронных компонентов;
- Поставка сложных, дефицитных, либо снятых с производства позиций;
- Оперативные сроки поставки под заказ (от 5 рабочих дней);
- Экспресс доставка в любую точку России;
- Техническая поддержка проекта, помощь в подборе аналогов, поставка прототипов;
- Система менеджмента качества сертифицирована по Международному стандарту ISO 9001;
- Лицензия ФСБ на осуществление работ с использованием сведений, составляющих государственную тайну;
- Поставка специализированных компонентов (Xilinx, Altera, Analog Devices, Intersil, Interpoint, Microsemi, Aeroflex, Peregrine, Syfer, Eurofarad, Texas Instrument, Miteq, Cobham, E2V, MA-COM, Hittite, Mini-Circuits, General Dynamics и др.);

Помимо этого, одним из направлений компании «ЭлектроПласт» является направление «Источники питания». Мы предлагаем Вам помощь Конструкторского отдела:

- Подбор оптимального решения, техническое обоснование при выборе компонента;
- Подбор аналогов;
- Консультации по применению компонента;
- Поставка образцов и прототипов;
- Техническая поддержка проекта;
- Защита от снятия компонента с производства.



Как с нами связаться

Телефон: 8 (812) 309 58 32 (многоканальный)

Факс: 8 (812) 320-02-42

Электронная почта: org@eplast1.ru

Адрес: 198099, г. Санкт-Петербург, ул. Калинина, дом 2, корпус 4, литера А.