

Description

The ZL38067 is part of Microsemi's Timberwolf audio processor family of products that combines the company's innovative *AcuEdge™* acoustic technology with Sensory's Truly Handsfree™ Voice Control. Microsemi ZL38067 improves Automatic Speech Recognition (ASR) performance at extended distances with barge-in capability and optimize for detecting voice commands.

The Microsemi *AcuEdge* Technology ZL38067 device is ideal for Connected Home applications. The device is capable of both voice control and 2-way full duplex audio with voice enhancements such as Acoustic Echo Cancellation (AEC), Noise Reduction (NR) to improve both the intelligibility and subjective quality of voice in harsh acoustic environments.

Microsemi offers additional tools to speed up the product development cycle. The MiTuner™ ZLS38508 or ZLS38508LITE GUI software packages allow a user to interactively configure the ZL38067 device. The optional ZLE38470BADA Automatic Tuning Kit provides automatic tuning and easy control for manual fine tuning adjustments.

Applications

- Integrated smart home gateways
- Connected home devices:
 - Thermostats
 - Smart Speakers
 - Security Systems
 - Digital Assistants
 - Alarm Clock/Radio Units

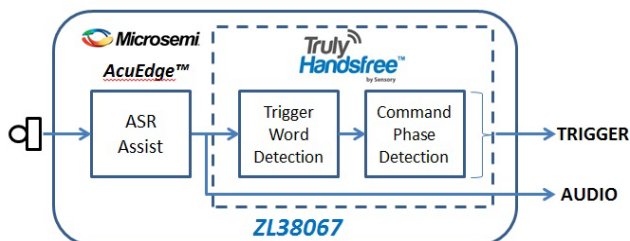

Document ID# 155522

Version 3

December 2016

Ordering Information

Device OPN	Package	Packing
ZL38067LDF1	64-pin QFN (9x9)	Tape & Reel
ZL38067LDG1	64-pin QFN (9x9)	Tray
ZL38067UGB2	56-ball WLCSP (3.1x3.1)	Tape & Reel

These packages meet RoHS 2 Directive 2011/65/EU of the European Council to minimize the environmental impact of electrical equipment.

Microsemi *AcuEdge* Technology ZLS38067 Firmware

There are three Firmware images that may be selected to provide the desired operating mode. Firmware images can be swapped during normal operation to switch modes dynamically. Firmware image size varies with firmware load.

ZLS38067.1 (Stand-alone ASR)

- Detection of a fixed trigger in 'spotting' mode (ability to detect trigger even in continuous speech).
- Detection of up to 20 command phrases after the trigger detection.
- Generation of a wake-on-trigger signal to wake up another device to enable full-duplex voice communication.

ZLS38067.2 (ASR with Barge-In)

- All of the features of the ZLS38067.1 for a trigger and up to 10 command phrases, PLUS:
- Support for Barge-in, or incoming trigger 'spotting', even in the presence of DAC audio output
- Enhanced far field support for distances up to 16 feet from the microphone.
- Command phrase demarcation to assist in framing audio samples for cloud-ASR streaming.

ZLS38067.0 (Full Duplex Communication)

- Full Narrowband and Wideband Acoustic Echo cancellation operation
 - Supports long tail AEC (up to 256 ms)
 - Non-Linear AEC provides higher tolerance for speaker distortions
 - Non-Linear processor
- Howling detection/cancellation
 - Prevents oscillation in AEC audio path

- G.168 Line Echo Canceller
- Advanced noise reduction reduces background noise from the near-end speech signal using Psychoacoustic techniques
- Provisions for stereo audio mixing (sample rate of 44.1 or 48 kHz) and stereo music record and playback (sample rate of 48 kHz) with 8 kHz or 16 kHz voice processing
- Various encoding/decoding options:
 - 16-bit linear, G.722, G.711 A/μlaw
- Send and receive path equalizers
- Caller ID Type 1 & 2
- Programmable tone generation
- DTMF detection
- Dual $\Delta\Sigma$ 16-bit digital-to-analog converters (DAC)
 - Sampling up to 48 kHz and internal output drivers
 - Headphone amps capable of 4 single-ended or 2 differential outputs
 - 32 mW output drive power into 16 ohms
 - Impulse pop/click protection
- 1 Digital Microphone input supporting 1 or 2 Microphones
- 2 TDM ports shared between PCM and Inter-IC Sound (I²S)
 - Each port can be a clock master or a slave
 - Each port supports delayed and non-delayed (GCI) timing and I²S normal and left justified modes
 - Each port provides sample rate conversion and synchronous TDM bus operation

ZLS38067 Hardware Features

- DSP with Voice Hardware Accelerators
- SPI or I²C Slave port for host processor interface
- General purpose UART port for debug
- Master SPI port for serial Flash interface
- Boots from SPI or Flash
 - Flash firmware can be updated from SPI Slave
- 14 General Purpose Input/Output (GPIO) pins (11 with the 56 pin WLCSP)
- 2 low power modes controlled by reset

The *MiTuner*™ Automatic Tuning Kit and ZLS38508 *MiTuner* GUI

Microsemi's Automatic Tuning Kit option includes:

- Audio Interface Box hardware
- Microphone and Speaker
- ZLS38508 *MiTuner* GUI software
 - Allows tuning of Microsemi's *AcuEdge* Technology Audio Processor

The ZLS38508 software features:

- Auto Tuning and Subjective Tuning support
- Provides visual representations of the audio paths with drop-down menus to program parameters, allowing:
 - Control of the audio routing configuration
 - Programming of key blocks in the transmit (Tx) and receive (Rx) audio paths
 - Setting analog and digital gains
- Configuration parameters allow users to “fine tune” the overall performance



Tools

- ZLK38000 Evaluation Kit
- *MiTuner*™ ZLS38508 and ZLS38508LITE GUI
- *MiTuner*™ ZLE38470BADA Automatic Tuning Kit

Table of Contents

1.0 ZL38067 Device Overview	7
2.0 Firmware	8
2.1 Full Duplex Communication Mode (ZL38067.0)	9
2.2 ASR Mode (ZL38067.1)	9
2.3 Barge-in Mode (ZL38067.2)	10
3.0 Audio Interfaces	10
3.1 Digital Microphone Interface	10
3.1.1 ASR Modes (ZLS38067.1 or ZLS38067.2)	10
3.1.2 Full Duplex Communication Mode (ZLS38067.0)	10
3.1.3 Analog Microphone Use	11
3.2 DAC Output - Full Duplex Communication Mode (ZLS38067.0)	12
3.2.1 Output Driver Configurations	12
3.3 DAC and Reference Bias Circuits	13
4.0 Digital Interfaces	15
4.1 TDM Interface - Full Duplex Communication Mode (ZLS38067.0)	15
4.1.1 I2S Mode	16
4.1.2 PCM Mode	17
4.1.3 GCI Mode	20
4.2 Cross Point Switch - Full Duplex Communication Mode (ZLS38067.0)	20
4.3 Host Bus Interface	21
4.3.1 SPI Slave	21
4.3.2 I2C Slave	23
4.3.3 UART	23
4.3.4 Host Interrupt Pin	24
4.4 Master SPI	24
4.4.1 Flash Interface	24
4.4.1.1 Flash Selection	25
4.5 GPIO	26
5.0 Reset	26
6.0 Power Supply	27
6.1 Power Supply Sequencing/Power up	27
6.1.1 Power Supply Considerations	27
6.1.1.1 External +1.2 V Power	27
6.1.1.2 Internal +1.2 V Power	28
6.1.1.3 Ultra-Low Power Mode	29
7.0 Device Booting and Firmware Swapping	31
7.1 Boot Loader	31
7.2 Bootstrap Modes	31
7.3 Loadable Device Code	31
7.3.1 Boot Speed	32
7.4 Bootup Procedure	32
8.0 Device Pinouts	33
8.1 64-Pin QFN	33
8.2 56-Ball WLCSP	34
9.0 Pin Descriptions	35
10.0 Electrical Characteristics	42
10.1 Absolute Maximum Ratings	42
10.2 Thermal Resistance	42
10.3 Operating Ranges	42
10.4 Device Operating Modes	43
10.4.1 Normal	43

Table of Contents

10.4.2 Low-Power	43
10.4.3 Sleep	43
10.4.4 Reset	43
10.4.5 Ultra-Low Power	44
10.4.6 Current Consumption	45
10.5 DC Specifications	46
10.6 AC Specifications	46
10.6.1 Microphone Interface	46
10.6.2 DAC	47
10.7 External Clock Requirements	48
10.7.1 Crystal Application	49
10.7.2 Clock Oscillator Application	49
10.7.3 PCLKA (Crystal-less) Application	50
10.7.4 AC Specifications - External Clocking Requirements	50
11.0 Timing Characteristics	50
11.1 TDM Interface Timing Parameters	52
11.1.1 GCI and PCM Timing Parameters	52
11.1.2 I2S Timing Parameters	55
11.1.2.1 I2S Slave	55
11.1.2.2 I2S Master	56
11.2 Host Bus Interface Timing Parameters	57
11.2.1 SPI Slave Port Timing Parameters	57
11.2.2 I2C Slave Interface Timing Parameters	58
11.3 UART Timing Parameters	59
11.4 Master SPI Timing Parameters	60
12.0 AEC Tuning	61
13.0 Package Outline Drawings	62
14.0 Revision History	66

Figure 1 - Alert Monitoring and Wideband Intercom Application	7
Figure 2 - ZL38067 ASR Audio Processor	8
Figure 3 - Stand-alone and Barge-in ASR Digital Microphone Interface	10
Figure 4 - Single Mono Digital Microphone Interface - Full Duplex Communications Firmware	11
Figure 5 - Dual Microphone or Stereo Digital Microphone Interface - Full Duplex Communications Firmware	11
Figure 6 - ECM Circuit	12
Figure 7 - Audio Output Configurations	13
Figure 8 - ZL38067 Bias Circuit	14
Figure 9 - I2S Mode	16
Figure 10 - Left Justified Mode	17
Figure 11 - Dual Codec Configuration - Full Duplex Communications Firmware	17
Figure 12 - TDM - PCM Slave Functional Timing Diagram (8-bit, xeDX = 0)	18
Figure 13 - TDM - PCM Slave Functional Timing Diagram (8-bit, xeDX = 1)	19
Figure 14 - TDM - PCM Master Functional Timing Diagram (8-bit, xeDX = 0)	19
Figure 15 - TDM - PCM Master Functional Timing Diagram (8-bit, xeDX = 1)	19
Figure 16 - TDM - GCI Slave Functional Timing Diagram	20
Figure 17 - TDM - GCI Master Functional Timing Diagram	20
Figure 18 - SPI Slave Byte Framing Mode - Write	21
Figure 19 - SPI Slave Byte Framing Mode - Read	22
Figure 20 - SPI Slave Word Framing Mode - Write, Multiple Data Words	22
Figure 21 - SPI Slave Word Framing Mode - Read, Multiple Data Words	22
Figure 22 - SPI Slave Command Framing Mode - Write	23
Figure 23 - SPI Slave Command Framing Mode - Read	23
Figure 24 - Flash Interface Circuit	24
Figure 25 - External +1.2 V Power Supply Configuration	28
Figure 26 - Internal +1.2 V Power Supply Configuration	29
Figure 27 - Ultra-Low Power Operation Circuit	30
Figure 28 - ZL38067 64-Pin QFN - Top View	33
Figure 29 - ZL38067 56-Ball WLCSP - Top View	34
Figure 30 - THD+N Ratio versus Output Power - Driving Low Impedance	48
Figure 31 - THD+N Ratio versus VRMS - Driving High Impedance	48
Figure 32 - Crystal Application Circuit	49
Figure 33 - Clock Oscillator Application Circuit	49
Figure 34 - Crystal-less Application Circuit	50
Figure 35 - Timing Parameter Measurement Digital Voltage Levels	51
Figure 36 - GCI Timing, 8-bit	53
Figure 37 - PCM Timing, 8-bit with xeDX = 0 (Transmit on Negative PCLK Edge)	53
Figure 38 - PCM Timing, 8-bit with xeDX = 1 (Transmit on Positive PCLK Edge)	54
Figure 39 - Slave I2S Timing	55
Figure 40 - Master I2S Timing	56
Figure 41 - SPI Slave Timing	58
Figure 42 - I2C Timing Parameter Definitions	59
Figure 43 - UART_RX Timing	59
Figure 44 - UART_TX Timing	59
Figure 45 - Master SPI Timing	60
Figure 46 - AIB System Board Connection	61
Figure 47 - 64-Pin QFN	62
Figure 48 - Recommended 64-Pin QFN Land Pattern - Top View	63
Figure 49 - 56-Ball WLCSP	64
Figure 50 - 56-Ball WLCSP Staggered Balls Expanded Bottom View	65

List of Tables

Table 1 - Allowable TDM Configurations - Full Duplex Communications Firmware	15
Table 2 - HBI Slave Interface Selection	21
Table 3 - Flash Devices Tested with the ZL38067	25
Table 4 - Supported Flash Types	25
Table 5 - Q1 Component Options	29
Table 6 - Bootstrap Modes	31
Table 7 - Reset Pin Description	35
Table 8 - DAC Pin Descriptions	35
Table 9 - Microphone Pin Descriptions	36
Table 10 - TDM and I2S Ports Pin Descriptions	36
Table 11 - HBI - SPI Slave Port Pin Descriptions	38
Table 12 - Master SPI Port Pin Descriptions	39
Table 13 - Oscillator Pin Descriptions	39
Table 14 - UART Pin Descriptions	39
Table 15 - GPIO Pin Descriptions	39
Table 16 - Supply and Ground Pin Descriptions	40
Table 17 - No Connect Pin Description	41
Table 18 - List of Changes to the Preliminary Data Sheet	66

1.0 ZL38067 Device Overview

The ZL38067 integrates the Sensory Truly Hands Free™ Automatic Speech Recognition which provides the capability to recognize a trigger word and up to 20 command phrases. Recognition is speaker independent and does not require any end user training. Truly Hands Free™ also allows for trigger-to-command phase detection without the need of a pause. This provides a user friendly experience. Microsemi's AcuEdge™ ASR assist enhances the performance by providing barge-in support, noise reduction, and far field processing which extends the detection range.

The ZL38067 has three primary modes of operation: Automatic Speech Recognition (ASR) with extended vocabulary, Automatic Speech Recognition with ASR Assist, and Full Duplex Communications mode. The ZLS38067.0 firmware provides the Full Duplex communications mode, while the other firmware variants (ZLS38067.1, ZLS38067.2) provide the ASR with extended memory and ASR assist respectively.

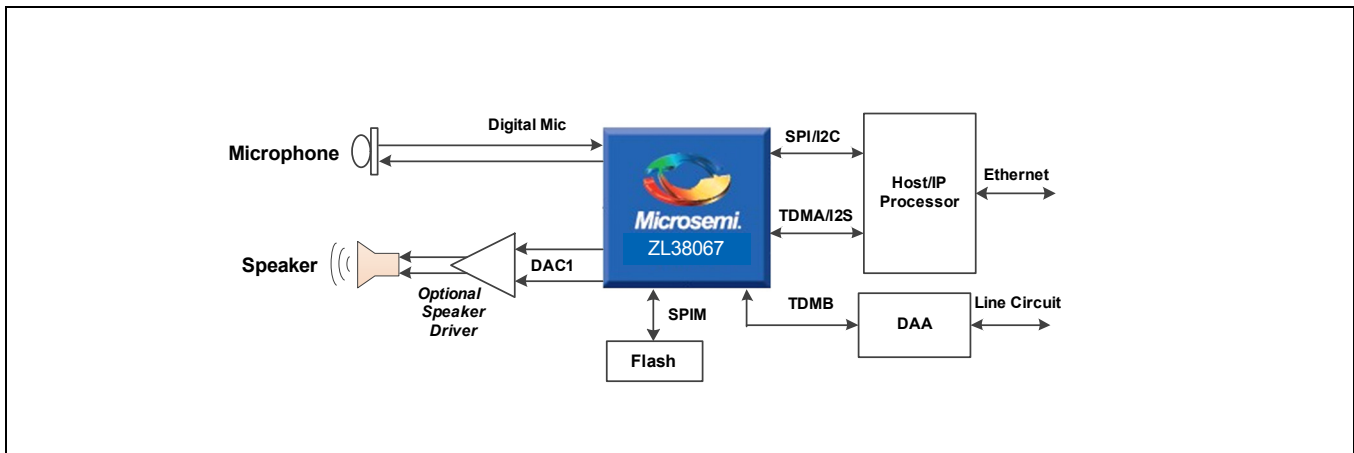

Figure 1 - Alert Monitoring and Wideband Intercom Application

For the Full Duplex Communications Firmware, the majority of the signal processing (AEC, Equalization, Noise Reduction etc.) runs in the Audio Processor Block. Each of the audio inputs (Digital Mics, I²S/TDM) and outputs (DACs, I²S/TDM) can be routed amongst themselves or to the Audio Processor via a highly configurable Cross Point Switch.

The main functional blocks of the device are shown in [Figure 2](#), a description of each block follows.

Refer to the Microsemi AcuEdge™ Technology ZLS38067 Firmware Manual for functional blocks of the Automatic Speech Recognition variants.

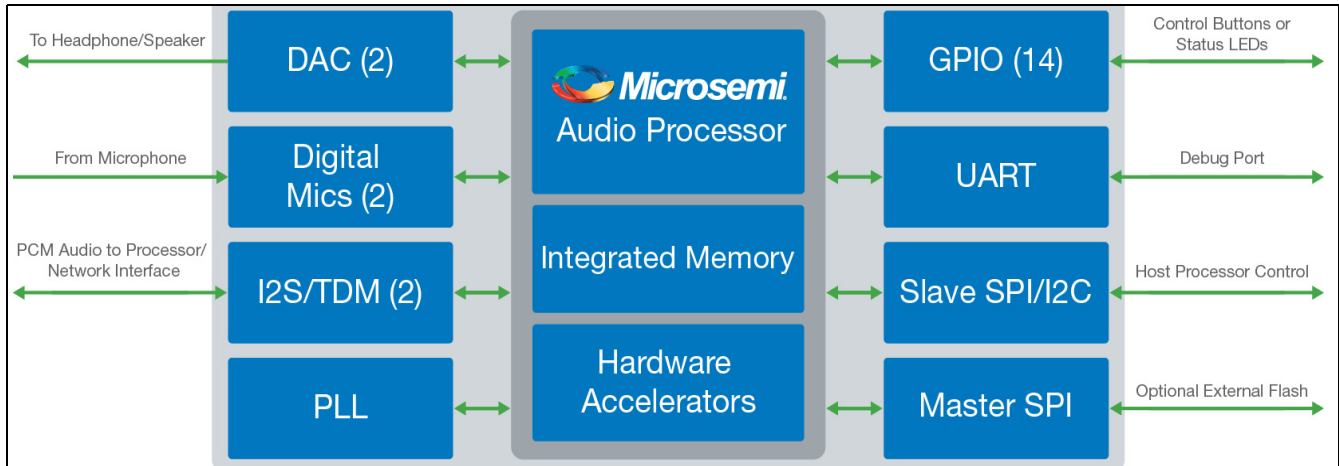

Figure 2 - ZL38067 ASR Audio Processor

2.0 Firmware

The three modes of operation in the ZL38067 (Full Duplex Communication, ASR with extended vocabulary, or ASR with ASR-assist) are selected depending on which Firmware is loaded into the device. The Firmware is initially loaded at power up, either from external serial Flash or from a host controller (see Section 7.0, “Device Booting and Firmware Swapping” on page 31). Real time switching between the Firmware modes can be done during normal operation. There are timing constraints that should be noted for Firmware swapping (see Section 11.2, “Host Bus Interface Timing Parameters” on page 57 for more information).

Please refer to the ZL38067 Firmware Manual for detailed information on the use of the three firmware modes.

The signal processing (which includes Acoustic Echo Cancellation, Equalization, Noise Reduction, Far-Field Mic) runs in the Audio Processor Block at 16 kHz. Each of the audio inputs (Digital Mics, I²S/TDM) and outputs (DACs, I²S/TDM) can be routed amongst themselves or to the Audio Processor via a highly configurable Cross Point Switch.

The ZL38067 device provides the following peripheral interfaces:

- 1 digital microphone interface allowing sampling of 1 or 2 digital microphones
- 2 Time-Division Multiplexing (TDM) buses
 - The ports can be configured for Inter-IC Sound (I2S) or Pulse-Code Modulation (PCM) operation
 - PCM operation supports PCM and GCI timing, I2S operation supports I2S and left justified timing
 - Each port can be a clock master or a slave
 - Each port supports up to four bi-directional streams when configured in PCM mode or two bi-directional streams when configured for I2S mode at data rates from 128 kb/s to 8 Mb/s

- Sample rate conversions are automatically done when data is sent/received at different rates than is processed internally. Only integer conversions are allowed.
- SPI – The device provides two Serial Peripheral Interface (SPI) ports
 - The SPI Slave port is recommended as the main communication port with a host processor. The port provides the fastest means to Host Boot and configures the device's firmware and configuration record¹.
 - The Master SPI port is used to load the device's firmware and configuration record from external Flash memory (Auto Boot).
- I2C - The device provides one Inter-Integrated Circuit (I2C) port. (pins are shared with the SPI Slave port)
 - The I2C port can be used as the main communication port with a host processor, and can be used to Host Boot and configure the device's firmware and configuration record.
- UART – The device provides one Universal Asynchronous Receiver/Transmitter (UART) port.
 - The UART port can be used as a debug tool and is used for tuning purposes.
- GPIO – The device provides 14 General Purpose Input/Output (GPIO) ports (full operation with Full Duplex Communication Firmware, limited operation with ASR Firmware).
 - GPIO ports can be used for interrupt and event reporting, fixed function control, bootstrap options, as well as being used for general purpose I/O for communication and controlling external devices.
 - The 56 pin WLCSP package is limited to 11 GPIOs.

2.1 Full Duplex Communication Mode (ZL38067.0)

The ZL38067.0 Firmware offers sophisticated full duplex audio processing for voice communication. This mode includes Acoustic Echo Cancellation (AEC), Noise Reduction (NR) and a variety of other voice enhancements to improve both the intelligibility and subjective quality of voice in harsh acoustic environments.

The full duplex communication firmware (ZL38067.0) supports the following additional ports:

- 2 independent headphone drivers
- Dual 16-bit digital-to-analog converters (DACs)
- 16 ohms single-ended or differential drive capability
- 32 mW output drive power into 16 ohms

2.2 ASR Mode (ZL38067.1)

This mode of operation provides reliable ASR for the detection of a fixed trigger and up to 20 command phrases.

This mode of operation supports:

- Detection of a fixed trigger in 'spotting' mode (ability to detect trigger even in continuous speech)
- Detection of up to 20 command phrases² after the trigger detection
- Generation of a wake-on-trigger signal to wake up another device to act on the upcoming command phrase, or enable full-duplex voice communication

1. The configuration record is a set of register values that are customizable by the application developer to configure and tune the ZL38067 for a particular design. Refer to the Microsemi AcuEdge™ Technology ZL38067 Firmware Manual for firmware and configuration record information.

2. Assuming a variable memory size of around 4K for each command phrase.

2.3 Barge-in Mode (ZL38067.2)

This mode of operation provides reliable ASR in the presence of echo and noise for distances up to 16 feet from the microphone.

This mode of operation supports all of the ASR features of the ZL38067.1 for trigger and 10 command phrase detection, along with the addition of ASR assist features that include:

- Support for Barge-in, or incoming trigger ‘spotting’ in the presence of DAC audio output
- Detection of a fixed trigger in ‘spotting’ mode in the presence of echo and/or noise

3.0 Audio Interfaces

3.1 Digital Microphone Interface

3.1.1 ASR Modes (ZLS38067.1 or ZLS38067.2)

This firmware supports one digital microphone using the DMIC_CLK and DMIC_IN interface pins as shown in [Figure 3](#). The digital microphone clock output (DMIC_CLK) runs at 1.024 MHz.

Of the two possible microphone audio paths only one may be routed to the Audio Processing block for detection processing at a time. The other path may be routed to the TDM bus for use by the host or an external Codec. The selection as to which clock edge (rising/falling) is used to clock in the microphone data (left or right) is done via the Microphone Enable Configuration register (host writable over the HBI) or in the configuration record (loaded from Flash).



Figure 3 - Stand-alone and Barge-in ASR Digital Microphone Interface

An electret condenser microphone can be used with the digital microphone input by using a Digital Electret Microphone Pre-Amplifier device as shown in [Figure 6](#).

3.1.2 Full Duplex Communication Mode (ZLS38067.0)

This firmware supports up to two digital microphones using the DMIC_CLK and DMIC_IN interface pins.

The ZL38067 digital microphone clock output (DMIC_CLK) is either 1.024 MHz or 3.072 MHz depending on the selected TDM-A sample rate. Selecting an 8 kHz or 16 kHz TDM-A sample rate corresponds to a 1.024 MHz digital microphone clock and selecting a 48 kHz sample rate corresponds to a 3.072 MHz digital microphone clock. Microphone data is decimated and filtered to operate at the 8 kHz or 16 kHz sampling rate of the Audio Processing block. When there is no TDM-A bus to set the sample rate, the ZL38067 will operate from the crystal (or clock oscillator) and will pass digital audio from the microphones operating at a 48 kHz sampling rate.

Of the two possible microphone audio paths only one may be routed to the voice processing algorithms at a time, the other path may be routed to the TDM bus for use by the host or an external Codec. Alternatively the host

processor can switch different microphones to the voice processing inputs. AEC is performed only on the microphone selected to go to the ZL38067 voice processing section.

A stereo digital microphone, or two separate mono digital microphones, send two microphone channels on one pin by sending the data for one channel on the rising edge and one channel on the falling edge. Various digital microphone interfaces are presented in [Figures 4 - 5](#).

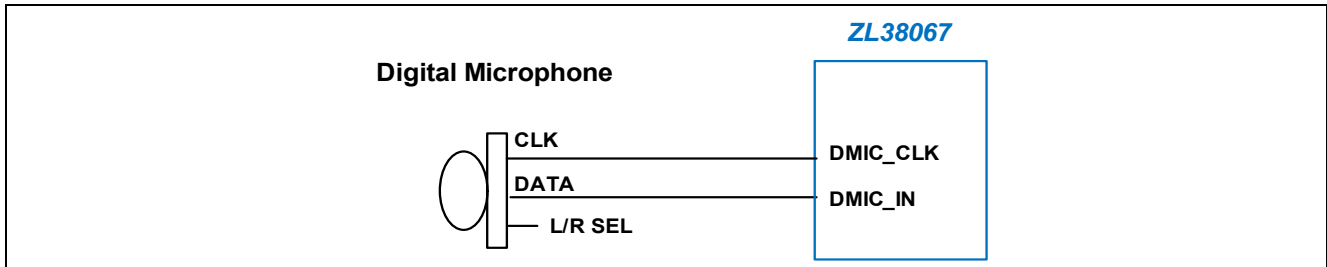

Figure 4 - Single Mono Digital Microphone Interface – Full Duplex Communications Firmware

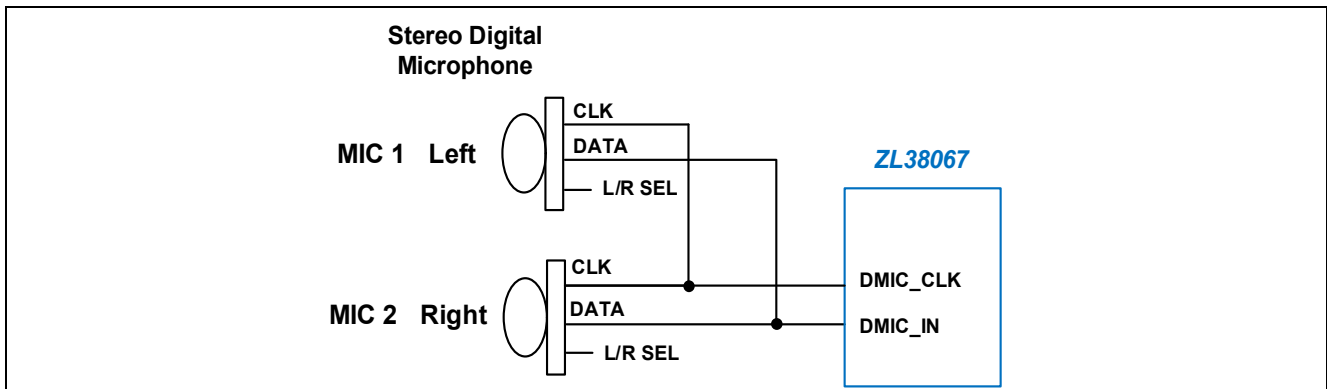

Figure 5 - Dual Microphone or Stereo Digital Microphone Interface – Full Duplex Communications Firmware

3.1.3 Analog Microphone Use

Electret condenser microphones can be used with the digital microphone interface by using a Digital Electret Microphone Pre-Amplifier device as shown in [Figure 6](#). External Codecs can also be used to connect to analog microphones. The external Codecs would interface to the ZL38067 via the TDM buses and the cross point switch would be used to route the TDM bus into the audio processing block.

To use analog electret condenser microphones (ECM) with the digital microphone interface, a Digital Electret Microphone Pre-Amplifier device is required. [Figure 6](#) illustrates an analog microphone connection.

The analog microphone is wired to an optional differential amplifier which can provide filtering and gain and converts the microphone signal to single-ended. The microphone signals are then further amplified and digitized through the Digital Electret Microphone Pre-Amplifiers and applied to the ZL38067 digital microphone input. A Microsemi AAP149B ECM Pre-Amplifier is shown. The ZL38067 provides the clock to activate the Digital Electret Microphone Pre-Amplifier.

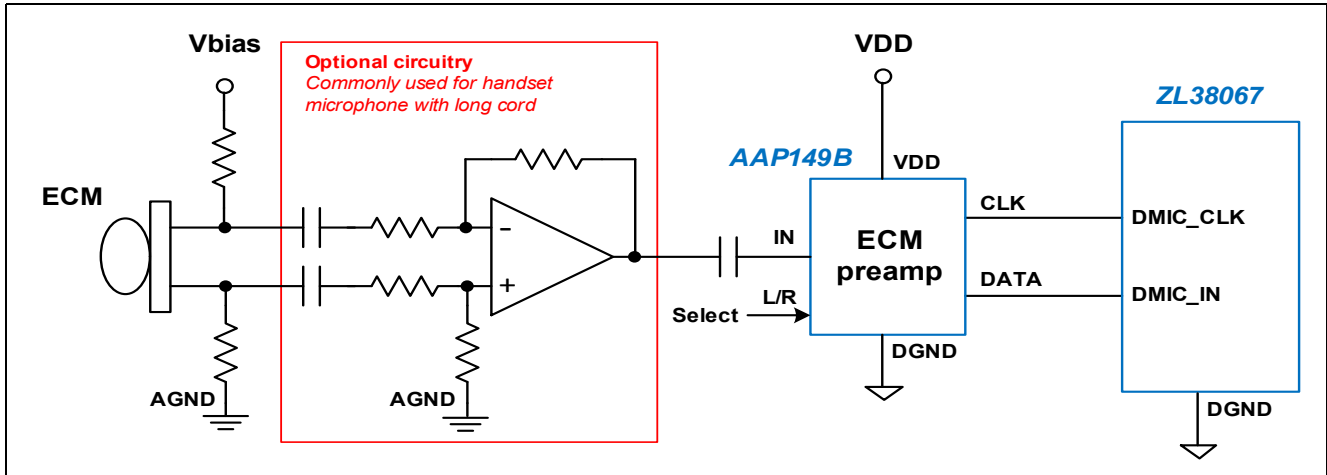

Figure 6 - ECM Circuit

When using an analog microphone, operation in Low-Power mode is not recommended. For more information, see [Section 10.4, “Device Operating Modes” on page 43](#).

3.2 DAC Output – Full Duplex Communication Mode (ZLS38067.0)

The Full Duplex Communication Mode supports two 16-bit fully differential delta-sigma digital-to-analog converters. The two output DACs that can drive 2 outputs either single ended or differentially. There are four analog gain settings on each DAC output are provided and can be set to: 1x, 0.5x, 0.333x, or 0.25x.

Note: Only the positive DAC outputs are available with the 56-ball WLCSP package. The 56-ball WLCSP package provides two independent single-ended headphone outputs that can be driven by two independent data streams.

The headphone amplifiers are self-protecting so that a direct short from the output to ground or a direct short across the terminals does not damage the device.

The ZL38067 provides audible pop suppression which reduces pop noise in the headphone earpiece when the device is powered on/off or when the device channel configurations are changed. This is especially important when driving a headphone single-ended through an external capacitor (see [3.2.1, “Output Driver Configurations”, configuration C](#)).

The DACs and headphone amplifiers can be powered down if they are not required for a given application. To fully power down the DACs, disable both the positive and negative outputs.

3.2.1 Output Driver Configurations

[Figure 7](#) shows the different possible output driver configurations for the 64-pin QFN package. When using the 56-ball WLCSP package, only the positive single ended outputs DAC1_P and DAC2_P are provided.

The two output DACs independently drive positive and negative headphone driver amplifiers. The output pins can be independently configured in the following ways:

- A. Direct differential drive of a speaker as low as 32 ohms. For this configuration an analog gain of 1x is commonly used. (Differentially driving a 16 ohm speaker is possible, but only with the same amount of power as in the single-ended case. The signal level must be reduced to not exceed ½ scale in this case.)
- B. Direct differential drive of a high impedance power amplifier. A Class D amplifier is recommended for this speaker driver. Use an ON Semiconductor® NCP2820 or equivalent. A 1 µF coupling capacitor is generally used with the Class D amplifier. The analog gain setting depends on the gain of the Class D amplifier,

analog gain settings of 0.25x or 0.5x are commonly used.

- C. Driving either a high impedance or a capacitively coupled speaker as low as 16 ohms single-ended. For this configuration an analog gain of 1x is commonly used. The coupling capacitor value can vary from 10 μf to 100 μf depending on the type of earpiece used and the frequency response desired.

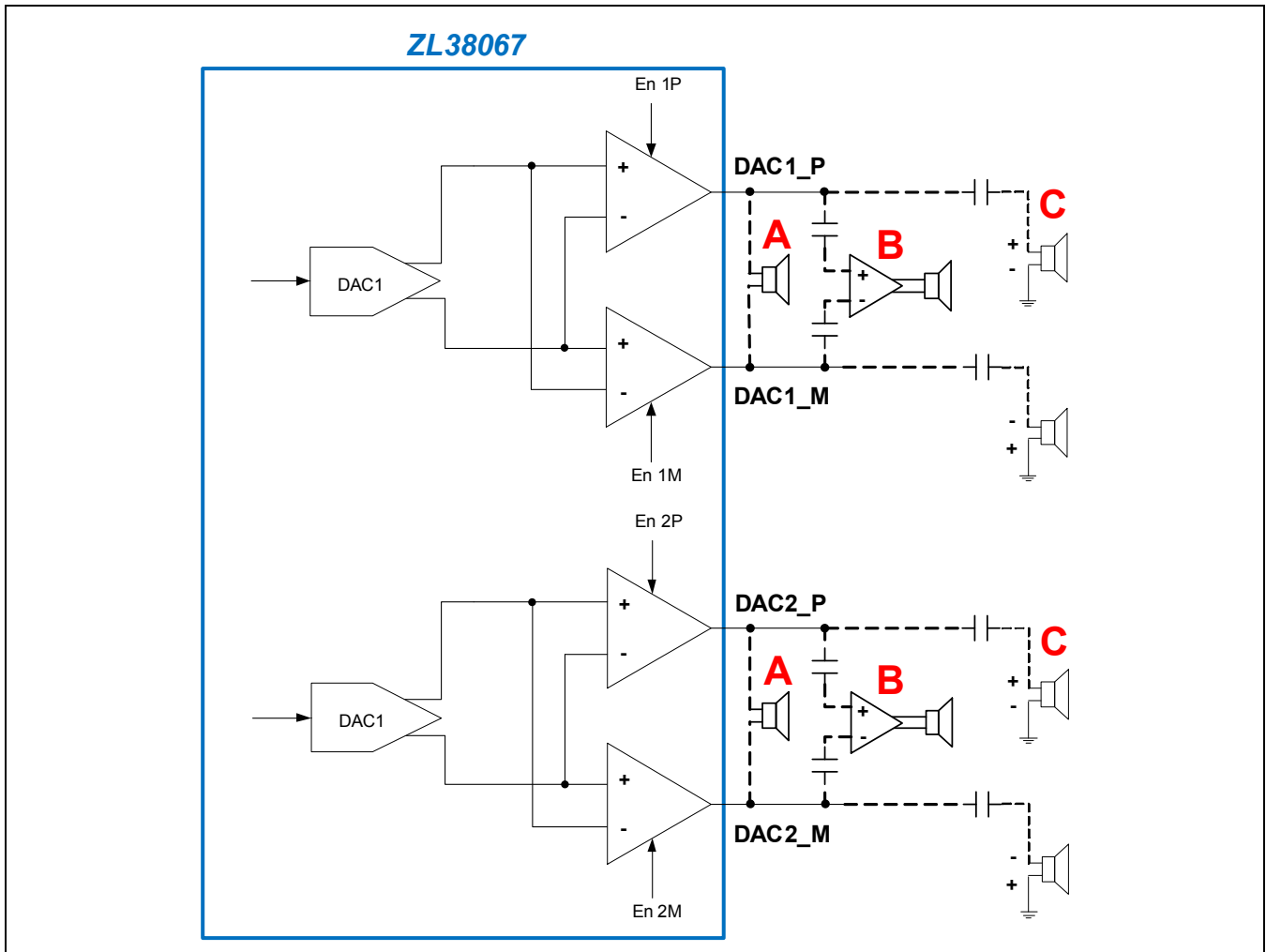

Figure 7 - Audio Output Configurations

3.3 DAC and Reference Bias Circuits

The common mode bias voltage output signal (CREF) must be decoupled through a 0.1 μF (C_{REF1}) and a 1.0 μF (C_{REF2}) ceramic capacitor to VSS.

The positive DAC reference voltage output (CDAC) must be decoupled through a 0.1 μF (C_{DAC}) ceramic capacitor to VSS as shown in [Figure 8](#) if a DAC is ever to be used. If solely using Alarm, Glass Break and Energy Detector Firmware, this capacitor is not required.

All capacitors can have a 20% tolerance and should have a minimum voltage rating of 6.3 V.

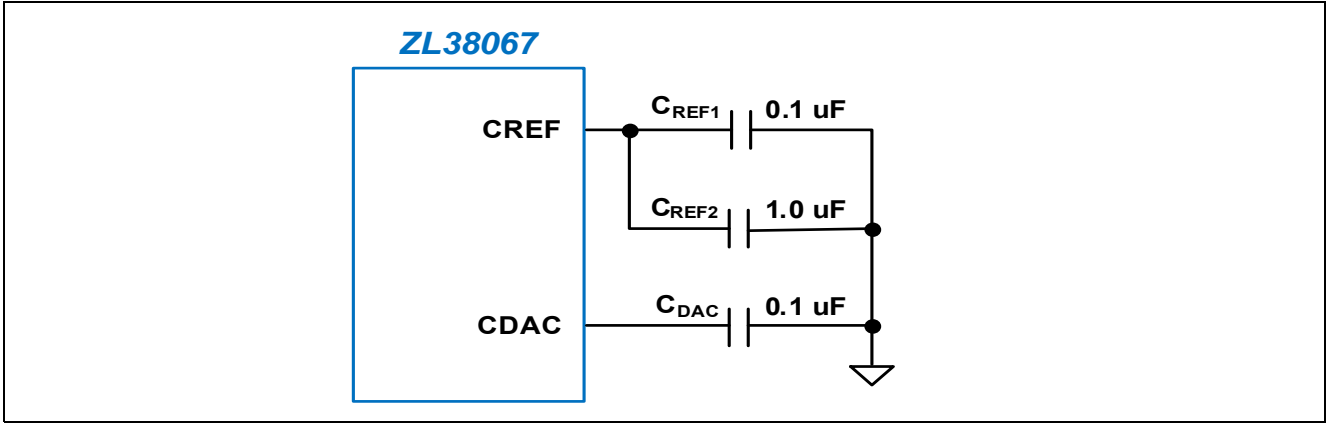

Figure 8 - ZL38067 Bias Circuit

4.0 Digital Interfaces

4.1 TDM Interface – Full Duplex Communication Mode (ZLS38067.0)

The Full Duplex Communications Mode supports two generic TDM interfaces, TDM-A and TDM-B. Each interface consists of four signals:

- Data clock (PCLK/I2S_SCK)
- Data rate sync (FS/I2S_WS)
- Serial data input (DR/I2S_SDI)
- Serial data output (DX/I2S_SDO)

The TDM ports can be configured for Inter-IC Sound (I²S) or Pulse-Code Modulation (PCM) operation.

Each TDM block is capable of being a master or a slave. Operation of the TDM interfaces are subject to the following limitations.

While a TDM bus configuration may carry many encoded audio streams, when using Full Duplex Communication Firmware, the ZL38067 device can only address a maximum of 4 bi-directional audio streams per TDM bus. These four audio streams are referred to as channels #1 through #4, and each of these channels can be independently configured to decode any of the TDM bus's audio streams.

For a given TDM bus, once it is configured for a data sample rate and encoding, all data rates and encoding on that bus will be the same. 16-bit linear data will be sent on consecutive 8-bit timeslots (e.g., if timeslot N is programmed in the timeslot registers, the consecutive timeslot is N+1).

The TDM interface supports bit reversal (LSB first \leftrightarrow MSB first) and loopbacks within the TDM interface and from one interface to another (see [“Cross Point Switch - Full Duplex Communication Mode \(ZLS38067.0\)” on page 20](#)).

The generic TDM interface supports the following mode and timing options.

Table 1 - Allowable TDM Configurations - Full Duplex Communications Firmware

TDM-A Mode	TDM-B Mode	Supported Sample Rates (kHz)	Requirements / Limitations
Master	Master	16, 48	Both TDM-A and TDM-B must be configured for the same data clock and data sync.
Master	Slave-Synchronous	16, 48	The TDM-B sync rate must be the same as the TDM_A sync rate or 48 kHz.
Slave	Master	16, 48	
Slave	Slave-Synchronous ¹	16, 48	

1. This combination requires that both TDM-A clock and TDM-B clock be physically connected to the same source.

4.1.1 I²S Mode

In I²S mode, the 4-wire TDM port conforms to the I²S protocol and the port pins become I2S_SCK, I2S_WS, I2S_SDI, and I2S_SDO (refer to [Table 10](#) for pin definitions). Both TDM buses have I²S capability.

An I²S bus supports two bi-directional data streams, left and right channel, by using the send and receive data pins utilizing the common clock and word signals. The send data is transmitted on the I2S_SDO line and the receive data is received on the I2S_SDI line.

The I²S port can be used to connect external analog-to-digital converters or Codecs. The port can operate in master mode where the ZL38067 is the source of the port clocks, or slave mode where the word select and serial clocks are inputs to the ZL38067.

The word select (I2S_WS) defines the I²S data rate and sets the frame period when data is transmitted for the left and right channels. A frame consists of one left and one right audio channel. When using Full Duplex Communication Firmware, the I²S ports operate as a slave or a master at sample rates as specified in [Table 1](#). Per the I²S standard, the word select is output using a 50% duty cycle.

The serial clock (I2S_SCK) rate sets the number of bits per word select frame period and defines the frequency of I2S_CLK. I²S data is input and output at the serial clock rate. Input data bits are received on I2S_SDI and output data bits are transmitted on I2S_SDO. Data bits are always MSB first. The number of clock and data bits per frame can be programmed as 8, 16, 32, 64, 96, 128, 192, 256, 384, 512, or 1024. Any input data bits that are received after the LSB are ignored.

The I²S port operates in two frame alignment modes (I²S and Left justified) which determine the data start in relation to the word select.

[Figure 9](#) illustrates the I²S mode, which is left channel first with I2S_WS (Left/Right Clock signal) low, followed by the right channel with I2S_WS high. The MSB of the data is clocked out starting on the second falling edge of I2S_SCK following the I2S_WS transition and clocked in starting on the second rising edge of I2S_SCK following the I2S_WS transition. [Figure 9](#) shows I²S operation with 32 bits per frame.

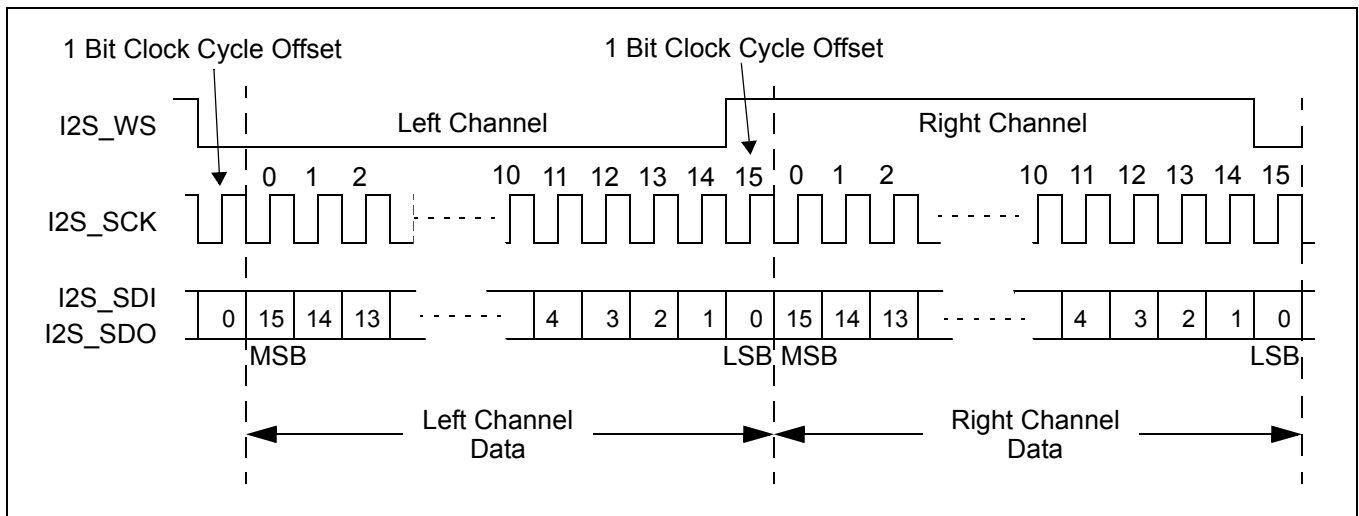

Figure 9 - I²S Mode

[Figure 10](#) illustrates the left justified mode, which is left channel first associated with I2S_WS (Left/Right Clock signal) high, followed by the right channel associated with I2S_WS low. The MSB of the data is clocked out starting on the falling edge of I2S_SCK associated with the I2S_WS transition, and clocked in starting on the first rising edge of I2S_SCK following the I2S_WS transition.

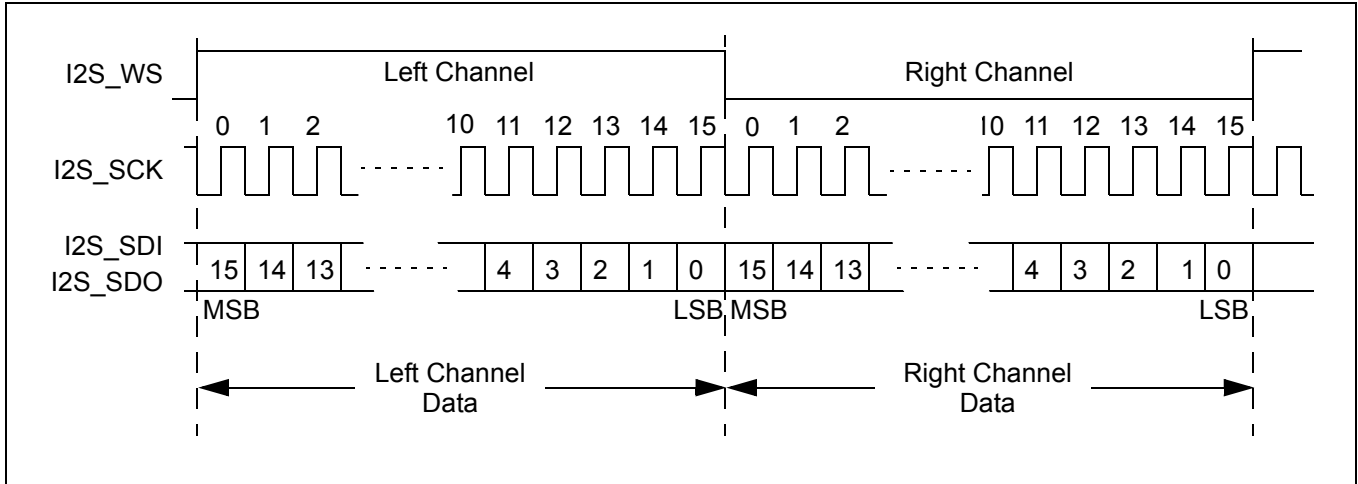

Figure 10 - Left Justified Mode

Each I²S interface can support one dual channel Codec (Figure 11) through the Codec's I²S interface. The four 16-bit channel processing capacity of the DSP is spread across the two input channels from the ADCs of Codec(0) and Codec(1), and the two output channels to the DACs of Codec(0) and Codec(1).

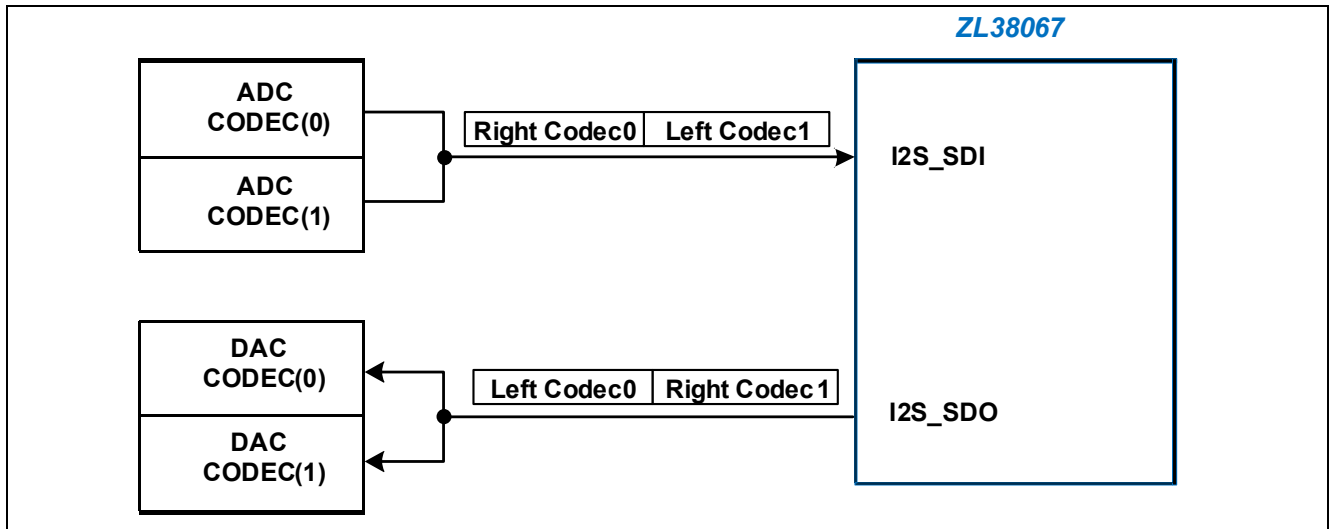

Figure 11 - Dual Codec Configuration – Full Duplex Communications Firmware

Both I²S bus modes can support full bi-directional stereo communication.

The device supports I²S loopback.

See the *Microsemi AcuEdge™ Technology ZLS38067 Firmware Manual* for I²S port registers.

4.1.2 PCM Mode

Each of the PCM channels can be assigned an independent timeslot. The timeslots can be any 8-bit timeslot up to the maximum supported by the PCLK being used.

The PCM ports can be configured for Narrowband G.711 A-law/ μ -Law or Linear PCM or Wideband G.722 encoding. For a given TDM bus, once it is configured for a data sample rate and encoding, all data rates and encoding on that

bus will be the same. 16-bit linear PCM will be sent on consecutive 8-bit timeslots (e.g., if timeslot N is programmed in the timeslot registers, the consecutive timeslot is N+1). The PCM interface can transmit/receive 8-bit compressed or 16-bit linear data with 8 kHz sampling (Narrowband), or 16-bit linear data with 16 kHz sampling (Wideband). Although the firmware allows it, 44.1 and 48 kHz sampling are not commonly used with PCM.

Wideband audio usually means the TDM bus is operating at a 16 kHz FS, but there are two other operating modes that support wideband audio using an 8 kHz FS:

- G.722 supports wideband audio with an 8 kHz FS. This uses a single 8-bit timeslot on the TDM bus.
- “Half-FS Mode” supports wideband audio with an 8 kHz FS signal. In this mode, 16-bit linear audio is received on two timeslot pairs; the first at the specified timeslot (N, N+1) and the second a half-frame later. In total, four 8-bit timeslots are used per frame, timeslots (N, N+1) and ((N + ((bits_per_frame)/16)), (N + 1 + ((bits_per_frame)/16))). The user programs the first timeslot and the second grouping is generated automatically 125/2 μ s from the first timeslot.

The PCM voice/data bytes can occupy any of the available timeslots, except for PCM clock rates that have extra clocks in the last timeslot. If there is more than one extra clock in the last timeslot, the timeslot data will be corrupted, do not use the last timeslot for these clock frequencies (e.g., 3.088 MHz etc.).

The PCM block can be configured as a master or a slave and is compatible with the Texas Instruments Inc. McBSP mode timing format.

[Figure 12](#) and [Figure 13](#) illustrate the PCM format with slave timing, FS and PCLK are provided by the host. Slave mode accommodates frame sync pulses with various widths (see [“GCI and PCM Timing Parameters” on page 52](#)).

[Figure 14](#) and [Figure 15](#) illustrate the PCM format with master timing, FS and PCLK are provided by the ZL38067. Master mode outputs a frame sync pulse equal to one PCLK cycle.

Diagrams for PCM transmit on negative edge (xeDX = 0) and PCM transmit on positive edge (xeDX = 1) are shown for both slave and master timing.

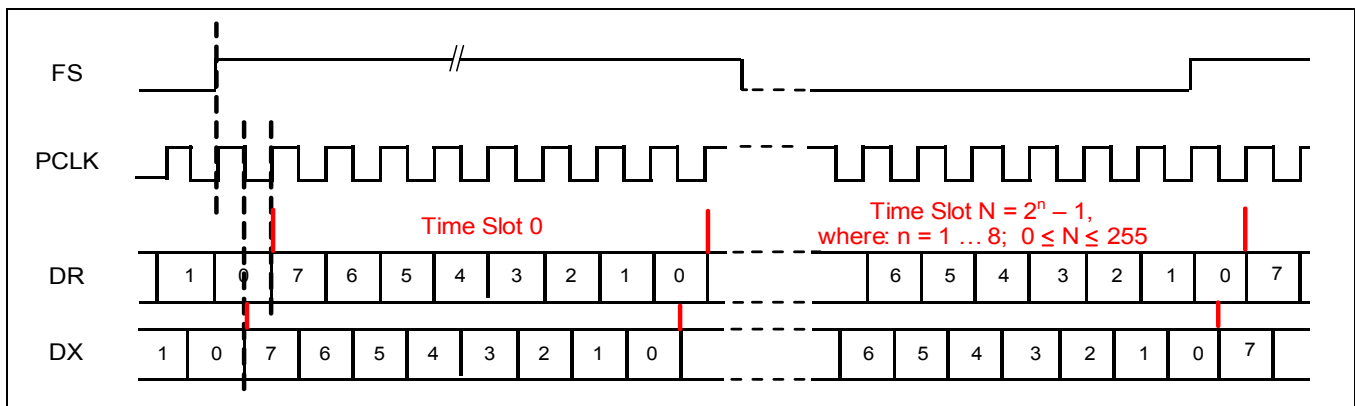

Figure 12 - TDM – PCM Slave Functional Timing Diagram (8-bit, xeDX = 0)

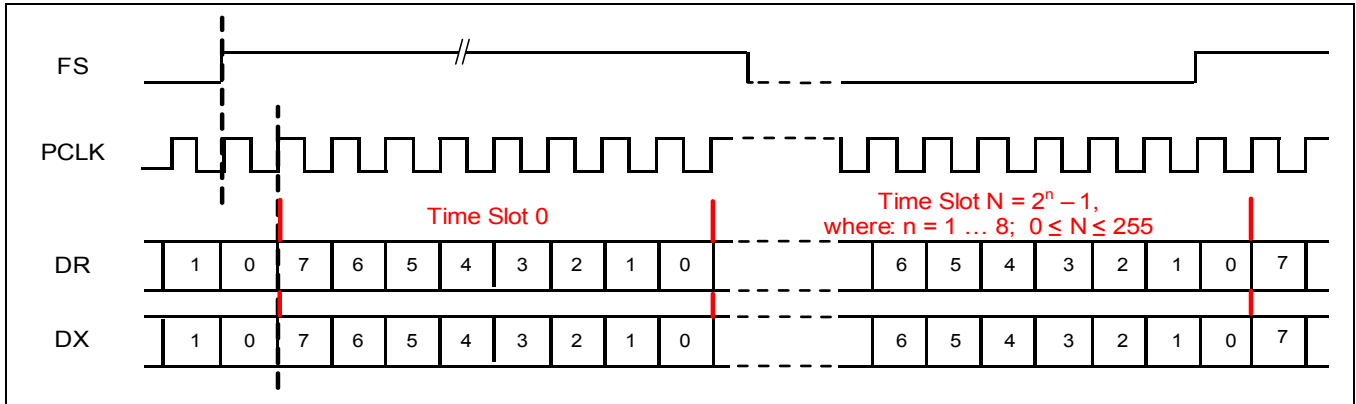

Figure 13 - TDM – PCM Slave Functional Timing Diagram (8-bit, xeDX = 1)

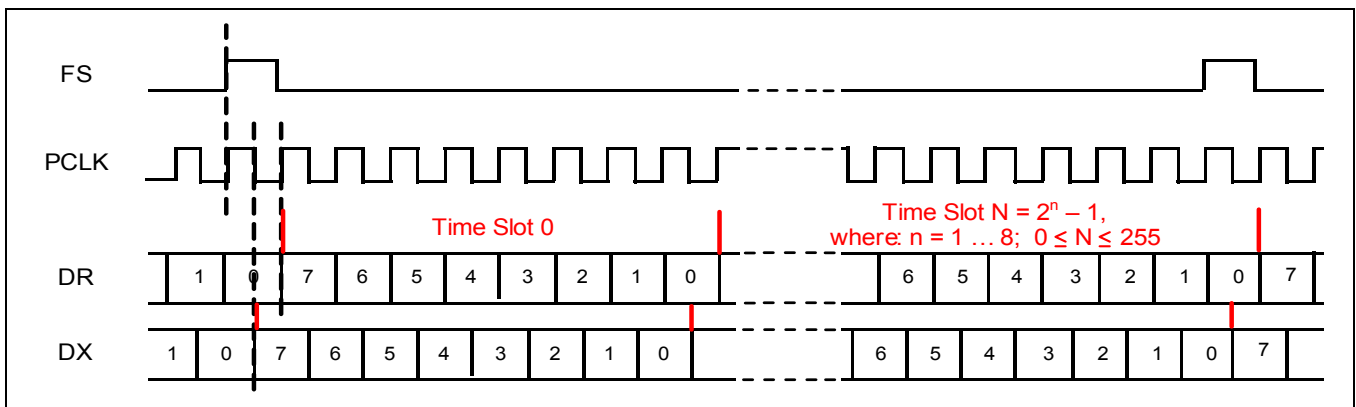

Figure 14 - TDM – PCM Master Functional Timing Diagram (8-bit, xeDX = 0)

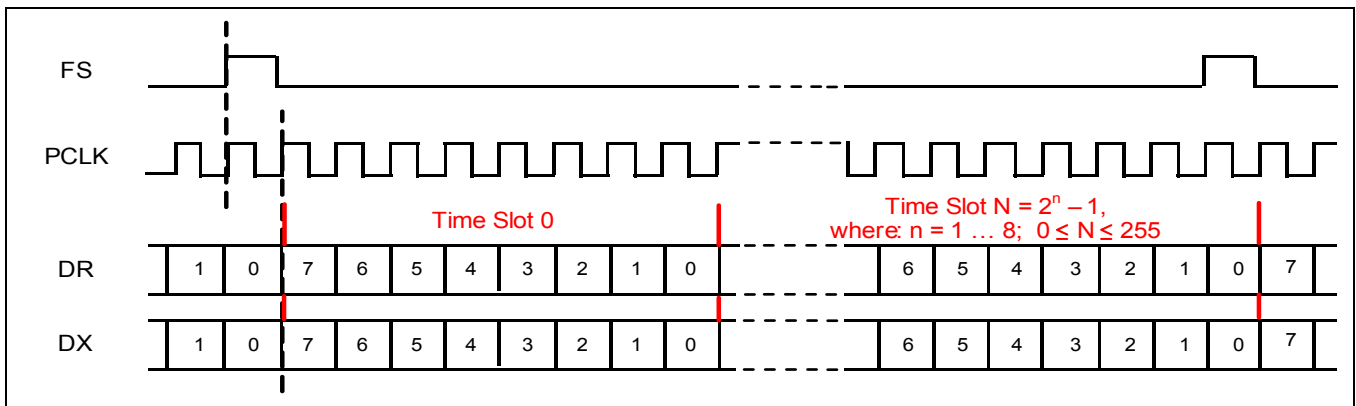

Figure 15 - TDM – PCM Master Functional Timing Diagram (8-bit, xeDX = 1)

4.1.3 GCI Mode

The GCI voice/data bytes can occupy any of the available timeslots. The GCI block can be configured as a master or a slave and supports a clock that has the same frequency as the data rate.

Note: Traditional GCI Monitor, Signalling, and Control channel bytes and double data rate are not supported.

[Figure 16](#) illustrates the GCI format with slave timing, FS and PCLK are provided by the host. Slave mode accommodates frame sync pulses with various widths (see [“GCI and PCM Timing Parameters” on page 52](#)).

[Figure 17](#) illustrates the GCI format with master timing, FS and PCLK are provided by the ZL38067. Master mode outputs a frame sync pulse equal to one PCLK cycle.

For both, first data bits are aligned with the rising edge of the frame sync pulse.

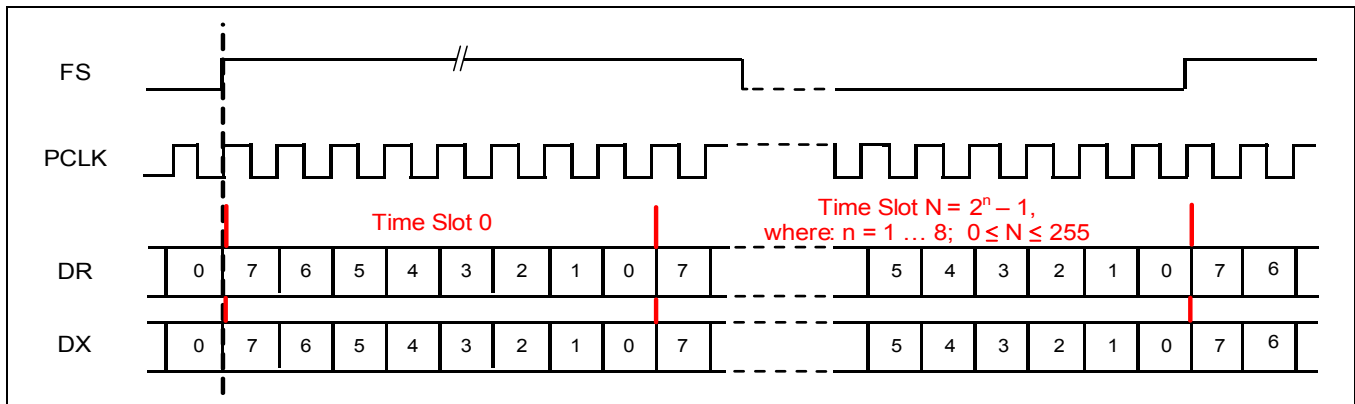

Figure 16 - TDM – GCI Slave Functional Timing Diagram

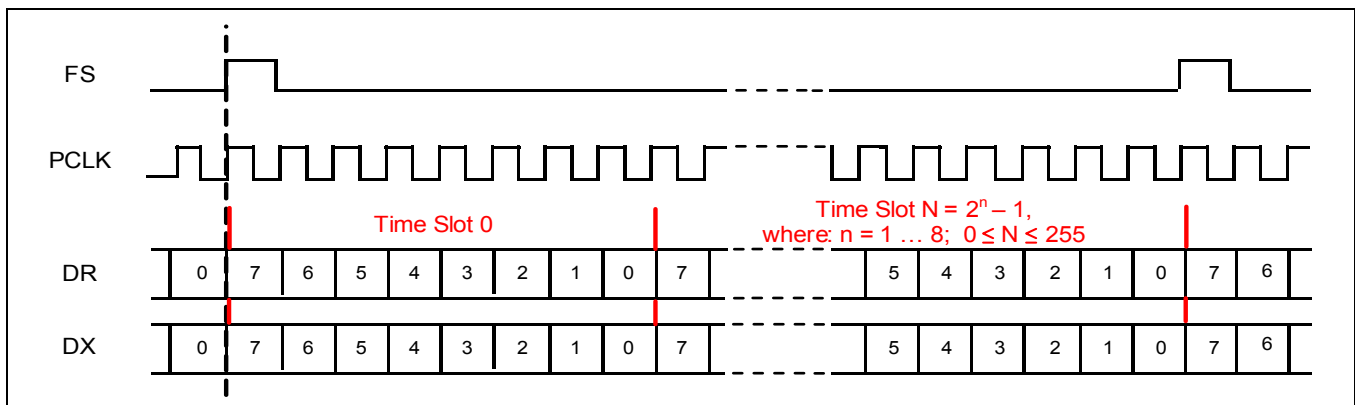

Figure 17 - TDM – GCI Master Functional Timing Diagram

4.2 Cross Point Switch – Full Duplex Communication Mode (ZLS38067.0)

The Full Duplex Communications Mode contains a Cross Point Switch that allows any input port to be routed to any output port as well as routing the input/outputs to/from the audio processor functions. Refer to the *Microsemi AcuEdge™ Technology ZLS38067 Firmware Manual* for Cross Point Switch operation and control.

4.3 Host Bus Interface

The host bus interface (HBI) is the main communication port from a host processor to the ZL38067. It can be configured to be either a SPI Slave or an I²C Slave port, either of which can be used to program or query the device.

The ZL38067 allows for automatic configuration between SPI and I²C operation. For the HBI port, if the HCLK toggles for two cycles, the HBI will default to the SPI Slave, otherwise it will remain configured as I²C (see [Table 2](#)). The HBI comes up listening in both SPI and I²C modes, but with I²C inputs selected. If HCLK is present, it switches the data selection before the first byte is complete so that no bits are lost. Once the port is determined to be SPI, a hardware reset is needed to change back to I²C.

This port can read and write all of the memory and registers on the ZL38067. The port can also be used to boot the device, refer to [“Device Booting and Firmware Swapping” on page 31](#).

Table 2 - HBI Slave Interface Selection

Description	Condition	Operating Mode	Notes
HBI Slave interface selection.	HCLK toggling	Host SPI bus	1
	HDIN tied to VSS	Host I ² C bus. Slave address 45h (7-bit).	
	HDIN tied to DVDD33	Host I ² C bus. Slave address 52h (7-bit).	

Note 1: By default, the HBI comes up as an I²C interface. Toggling the HCLK pin will cause the host interface to switch to a SPI interface. If an I²C interface is desired, HCLK needs to be tied to ground.

4.3.1 SPI Slave

The physical layer is a 4-wire SPI interface. Chip select and clock are both inputs.

The SPI Slave port can support byte, word, or command framing. Write and read diagrams for these framing modes are shown in [Figure 18](#) – [Figure 23](#). The SPI Slave chip select polarity, clock polarity, and sampling phase are fixed.

The ZL38067 command protocol is half duplex, allowing the serial in and serial out to be shorted together for a 3-wire connection. The chip select is active low. The data is output on the falling edge of the clock and sampled on the rising edge of the clock.

The SPI Slave supports access rates up to 25 MHz.

The outbound interrupt is always active low.

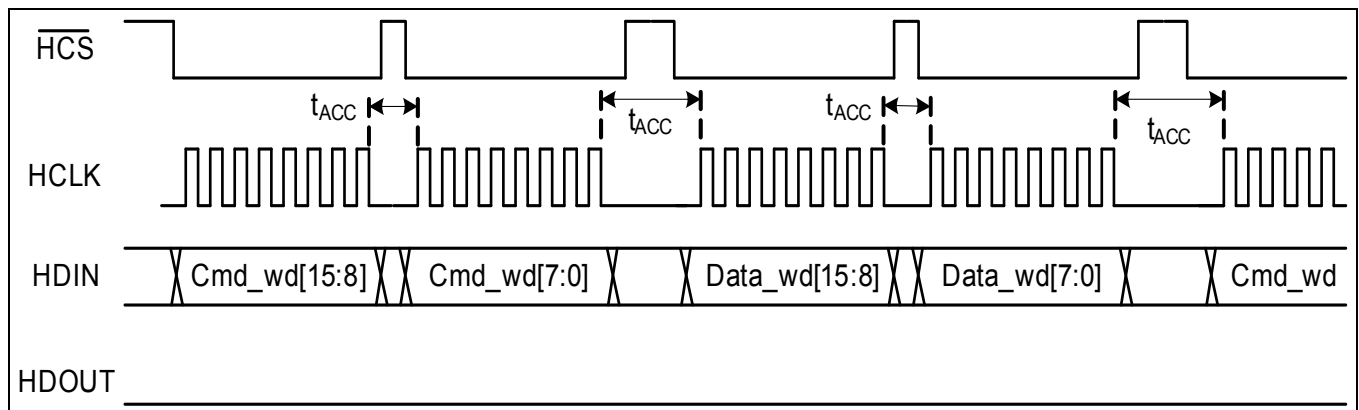

Figure 18 - SPI Slave Byte Framing Mode – Write

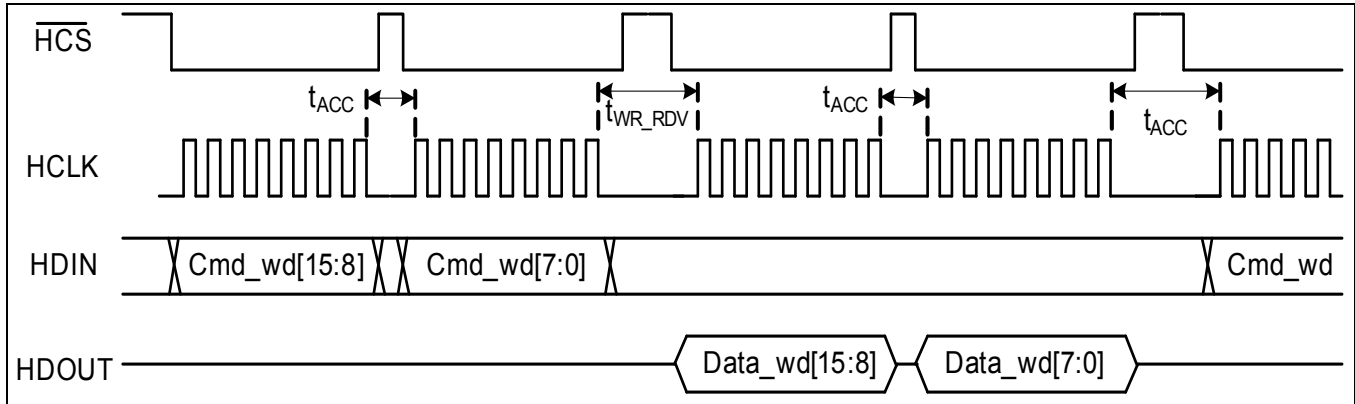

Figure 19 - SPI Slave Byte Framing Mode – Read

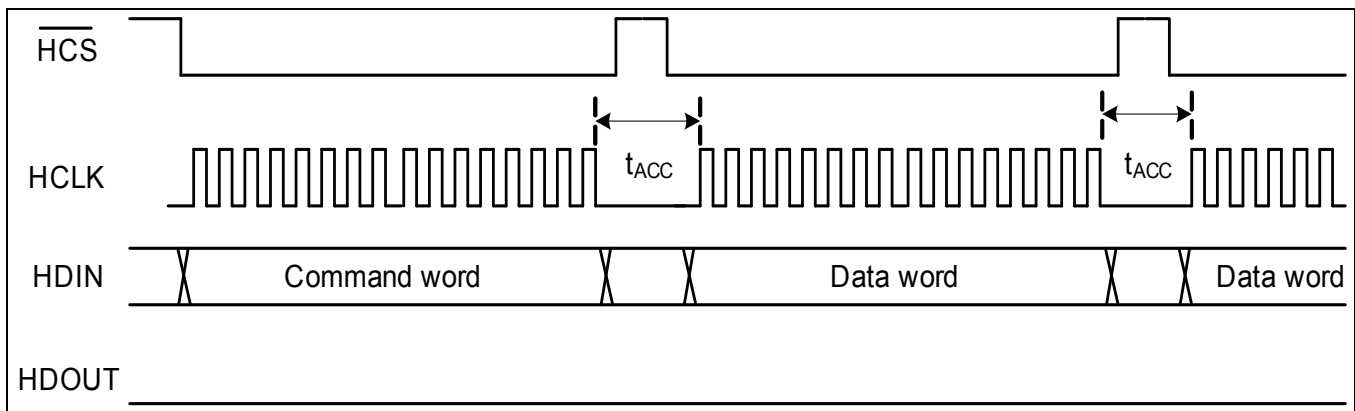

Figure 20 - SPI Slave Word Framing Mode – Write, Multiple Data Words

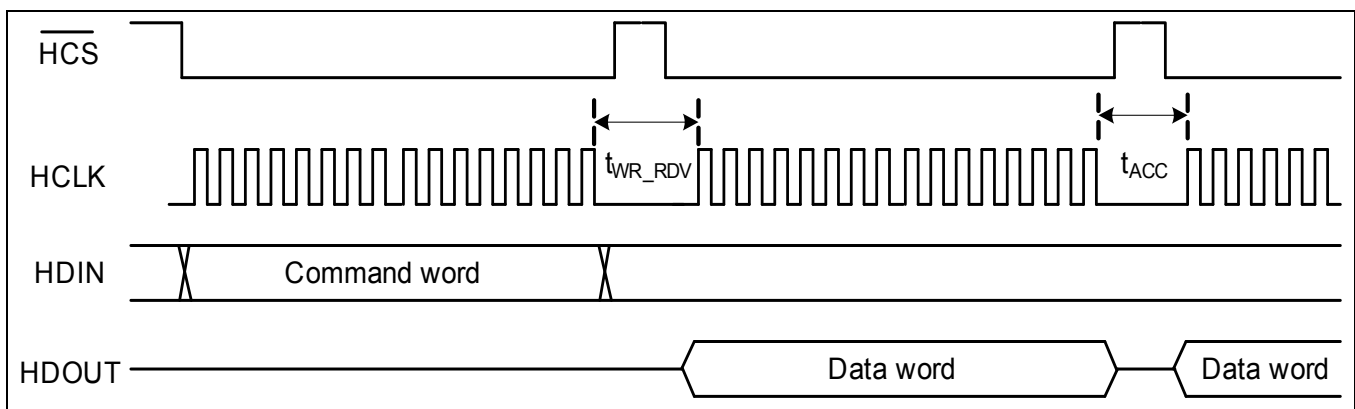

Figure 21 - SPI Slave Word Framing Mode – Read, Multiple Data Words

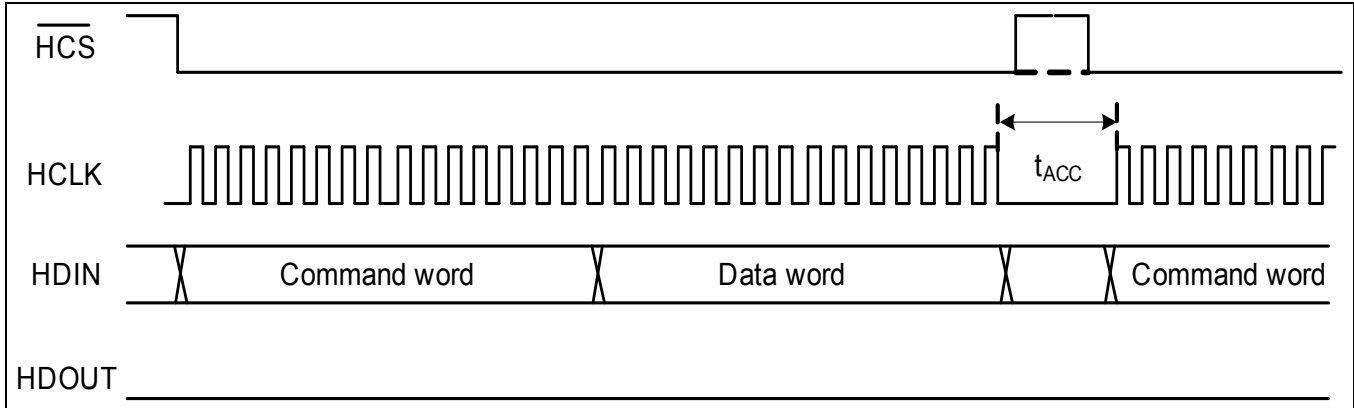

Figure 22 - SPI Slave Command Framing Mode – Write

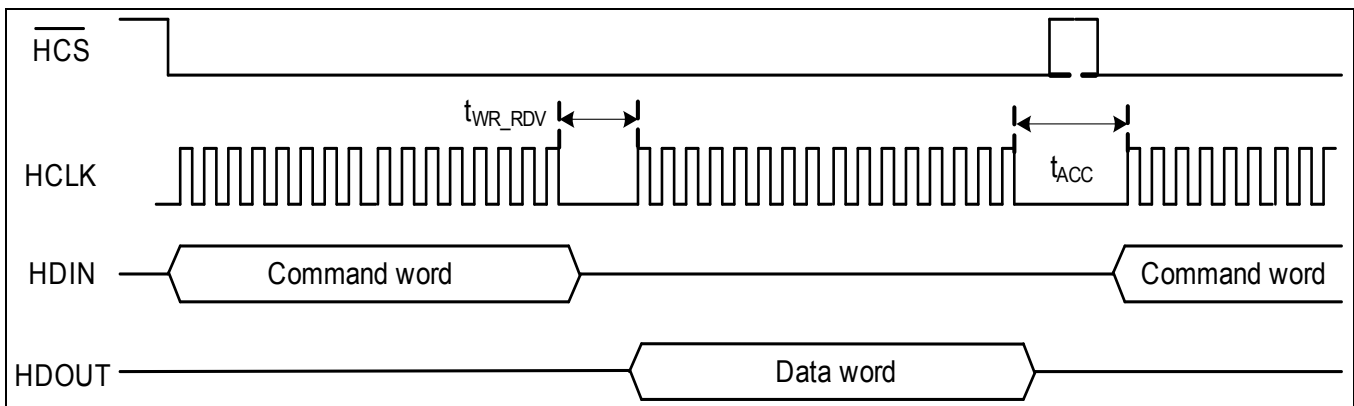

Figure 23 - SPI Slave Command Framing Mode – Read

4.3.2 I²C Slave

The I²C bus is similar to the Philips Semiconductor (NXP) 1998 Version 2.0, I²C standard. The ZL38067 I²C bus supports 7-bit addressing and transfer rates up to 400 kHz. External pull-up resistors are required on the I²C serial clock input (HCS) and the I²C serial data input/output (HDOUT) when operating in this mode (note, the I²C slave pins are 3.3 V pins and are not 5 V tolerant).

The selection of the I²C slave address is performed at bootup by the strapping of the HDIN and HCLK pins, see [Table 2](#).

4.3.3 UART

The ZL38067 device incorporates a two-wire UART (Universal Asynchronous Receiver Transmitter) interface with a fixed 115.2K baud transfer rate, 8 data bits, 1 stop and no parity. TX and RX pins allow bi-directional communication with a host. The UART pins must be made accessible on the PCB for debug and tuning purposes.

4.3.4 Host Interrupt Pin

An internal host interrupt controller controls the active low interrupt pin which is part of the host bus interface. Associated with the interrupt controller is an event queue which reports status information about which event caused the interrupts.

Upon sensing the interrupt, the host can read the event queue to determine which event caused the interrupt. Specific events are enabled by the host processor, and are typically not used with a standalone (controllerless) design.

Refer to Events in the *Microsemi AcuEdge™ Technology ZLS38067 Firmware Manual* for Event ID Enumerations.

4.4 Master SPI

Like the HBI SPI Slave, the physical layer of the Master SPI is a 4-wire SPI interface supporting half duplex communication. It supports only one chip select which is multiplexed with GPIO_9.

The Master SPI is only used by the built in boot ROM to load from an external serial Flash. The ZL38067 can automatically read the Flash data (program code and configuration record) through this interface upon the release of reset (Auto Boot), depending on the value of the bootstrap options.

Note: An alternative to Auto Boot is to perform a Host Boot through the HBI port. Refer to [Section 7.0, "Device Booting and Firmware Swapping" on page 31](#).

4.4.1 Flash Interface

After power-up the ZL38067 will run its resident boot code, which establishes the initial setup of the Master SPI port and then downloads the firmware from external Flash memory when configured for auto boot mode. This Flash firmware establishes the resident application and sets the configuration of all the ZL38067 ports.

[Figure 24](#) illustrates the connection of Flash memory to the ZL38067 Master SPI port. [Figure 24](#) and the ZLE38000 demonstration hardware uses the Macronix™ MX25L4006E 4 Mbit CMOS Serial Flash device.

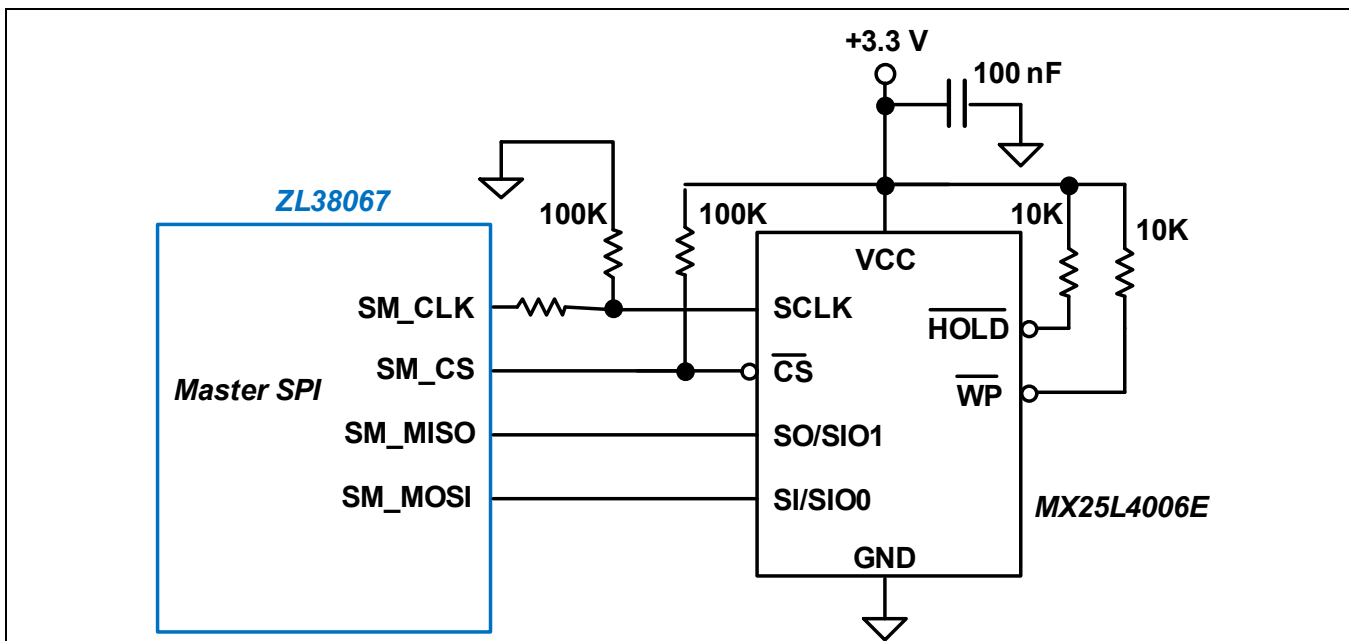

Figure 24 - Flash Interface Circuit

4.4.1.1 Flash Selection

The ZL38067 Boot ROM is designed to work with a wide variety of Flash devices. There are numerous Flash devices that the ZL38067 Boot ROM can recognize and program without host intervention other than a command to initialize the Flash. Other unrecognized devices may be utilized if they conform to certain characteristics of known devices and the host informs the ZL38067 Boot ROM of their type and size.

The ZL38067 identifies Flash devices (with a single binary image) with the ZL38067 boot ROM auto sensing the Flash type. The ZL38067 complies with JEDEC *Manufacturer and Device ID Read Methodology for SPI Compatible Serial Interface Memory Devices*. The ZL38067 is compatible with the *Serial Flash Discoverable Parameters* JEDEC standard JESD216B and the *Common Flash Interface* JESD68.01 JEDEC standard. The ZL38067 can identify devices by their JEDEC standard JEP106-K *Standard Manufacturer's Identification Code*.

Select a Flash size that is adequate to store all the firmware images required of the application. The image sizes can be obtained from the specific firmware releases.

A list of Flash devices that are identifiable by the ZL38067 Boot ROM are shown in [Table 3](#). The size of these devices are all 2 Mbit or 4 Mbit, the Boot ROM will also recognize the size of 8 Mbit parts that are Type 1 or Type 2 devices (as defined in [Table 4](#)).

Table 3 - Flash Devices Tested with the ZL38067

Manufacturer	Part Number	Description
Macronix™	MX25V4006EM1I-13G	4 Mbit Flash.
Winbond™	W25X40CLSNIG-ND	4 Mbit Flash.
	W25X20CLSNIG-ND	2 Mbit Flash.
Micron®	M25P20-VMN6PB	2 Mbit Flash. Large 512 Kbit sectors limit the usefulness of this device. Holds only 1 application image.
	M25P40-VMN6PB	4 Mbit Flash. Large 512 Kbit sectors limit the usefulness of this device. Holds only 2 or 3 application images.
Microchip™	SST25VF020B-80-4I	2 Mbit Flash.
Atmel®	AT25DF041A AT45DB041D	4 Mbit Flash. Must be used in its 256 byte page variant. The default configuration is a 264 byte page. It can be ordered or programmed to use a 256 byte page.
Spansion™	S25FL204K0TMF1010	4 Mbit Flash.
AMIC Technology	A25L020O-F	2 Mbit Flash.

Flash devices whose JEDEC ID or size (usually a size of 16 Mbit or larger) that are not recognized by the ZL38067 Boot ROM can be made to work if they fit the characteristics of one of the 4 Flash types listed in [Table 4](#). By writing the type (1, 2, 3, or 4) to ZL38067 address 0x118 and the number of sectors to ZL38067 address 0x116 prior to initializing the Flash device, the Boot ROM will treat it as a known device of known size even though the manufacturer ID or size field are not recognized.

Table 4 - Supported Flash Types

Characteristic	Type 1	Type 2	Type 3	Type 4
Sector Size	512 Kbit (64 KB)	32 Kbit (4 KB)	32 Kbit (4 KB)	16 Kbit (2 KB)
Read Status Reg Cmd	0x05	0x05	0x05	0xD7
Status Reg	Busy bit = 0x01	Busy bit = 0x01	Busy bit = 0x01	Done bit = 0x80

Data Read Cmd	0x03	0x03	0x03	0x03
Write Enable Cmd	0x06	0x06	0x06	N/A
Page Write Cmd	0x02	0x02	N/A Uses AAI to program word or byte. Uses Write Disable command to terminate AAI.	N/A Uses write from buffer command.
4-Byte Bulk Erase Cmd	N/A	N/A	N/A	0xC794809A
Examples	Micron® M25P20-VMN6PB M25P40-VMN6PB	Winbond™ W25X40CLSNIG-ND W25X20CLSNIG-ND Macronix™ MX25V4006EM1I-13G AMIC Technology A25L020O-F Spansion™ S25FL204K0TMF1010 Atmel® AT25DF041A	Microchip™ SST25VF020B-80-4I	Atmel® AT45DB021D AT45DB041D

4.5 GPIO

Note: GPIO functionality is limited with ASR related functionality. Refer to the Microsemi *AcuEdge™ Technology ZLS38067 Firmware Manual*.

The ZL38067 64-pin QFN package has 14 GPIO (General Purpose Input/Output) pins; the ZL38067 56-ball WLCSP package has 11 GPIO pins.

The GPIO pins can be individually configured as either inputs or outputs, and have associated maskable interrupts reported to the host processor through the interrupt controller and event queue. The GPIO pins are intended for low frequency signaling.

When a GPIO pin is defined as an input, the state of that pin is sampled and latched into the GPIO Read Register. A transition on a GPIO input can cause an interrupt and event to be passed to the host processor.

Certain GPIO pins have special predefined functions associated with the pin. Individual GPIO pins may also be defined as status outputs with associated enable/disable control. See Fixed Function I/O in the *Microsemi AcuEdge™ Technology ZLS38067 Firmware Manual*.

Immediately after any power-on or hardware reset the GPIO pins are defined as inputs and their state is captured in the GPIO Configuration Register. The state of this register is used to determine which options are selected for the device. The GPIO pin status is then redefined as specified in the configuration record that is loaded from the Flash or host.

In addition to the predefined fixed functions and the general functionality of the GPIO pins, the GPIO pins also support the bootstrap functions listed in [Table 6](#).

5.0 Reset

The device has a hardware reset pin ($\overline{\text{RESET}}$) that places the entire device into a known low power state. The device will perform either a digital or an analog reset depending on the duration of the reset pulse.

- Digital reset – When the reset pin is brought low for a duration of between 100 ns and 1 μ s, a digital reset occurs and all device states and registers are reset by this pin.
- Analog reset – When the reset pin is brought low for a duration greater than 10 μ s, both a digital and an analog reset will occur. The analog reset will deactivate the internally generated +1.2 V by shutting off the external FET and the internal PLL. Raising the reset pin high will immediately turn back on these supplies (requiring a corresponding PLL startup time, \sim 3 ms).

For both digital and analog reset cases when reset is released, the device will go through its boot process and the firmware will be reloaded. If the reset had been an analog reset, then the boot process will take longer waiting for the system clocks to power back on.

GPIO sensing will occur with either type of reset.

A 10 K Ω pull-up resistor is required on the $\overline{\text{RESET}}$ pin to DVDD33 if this pin is not continuously driven.

6.0 Power Supply

6.1 Power Supply Sequencing/Power up

No special power supply sequencing is required. The +3.3 V or +1.2 V power rails can be applied in either order.

Upon power-up, the ZL38067 begins to boot and senses the external resistors on the GPIO to determine the bootstrap settings. After 3 ms, the boot process begins and the ZL38067 takes less than 1 second to become fully operational (for Auto Boot from Flash, including the time it takes to load the firmware).

In order to properly boot, the clocks (and power supplies) to the device must be stable. This requires either the 12.000 MHz crystal or clock oscillator to be active and stable before the ZL38067's reset is released.

6.1.1 Power Supply Considerations

The ZL38067 requires +1.2 V to power its core DSP power supply (DVDD12). To achieve optimum noise and power performance, supply DVDD12 from an external source. Use an LDO regulator like the Microsemi LX8213 to achieve low noise and low overall power consumption. The ZL38067 is designed to minimize power in its active states when DVDD12 is supplied externally.

To further reduce power, the internal PLL can be shut-down as described in [6.1.1.3, "Ultra-Low Power Mode"](#).

6.1.1.1 External +1.2 V Power

[Figure 25](#) shows DVDD12 powered from an external supply. A Microsemi LX8213 300 mA Low Noise CMOS LDO Regulator is shown.

External supply use is selected when the EXT_SEL pin is tied to +3.3 V. The EXT_SEL pin can be pulled high or simply hard-wired to DVDD33.

VDD12_CTRL is a CMOS output which can be used to control the shutdown of the external supply. VDD12_CTRL will provide a steady +3.3 V output (with up to 4 mA of source current) for the external supply to be enabled and 0 V for the supply to be disabled.

For power savings when the ZL38067 does not need to be operational, the external voltage regulator can be turned off by pulling the $\overline{\text{RESET}}$ pin low for longer than 10 μ s (Reset mode). This action will force the VDD12_CTRL pin low, shutting off the external LDO and allowing the +1.2 V supply to collapse to 0 V.

If shutdown of the external +1.2 V supply is not desired, simply leave the VDD12_CTRL output pin floating.

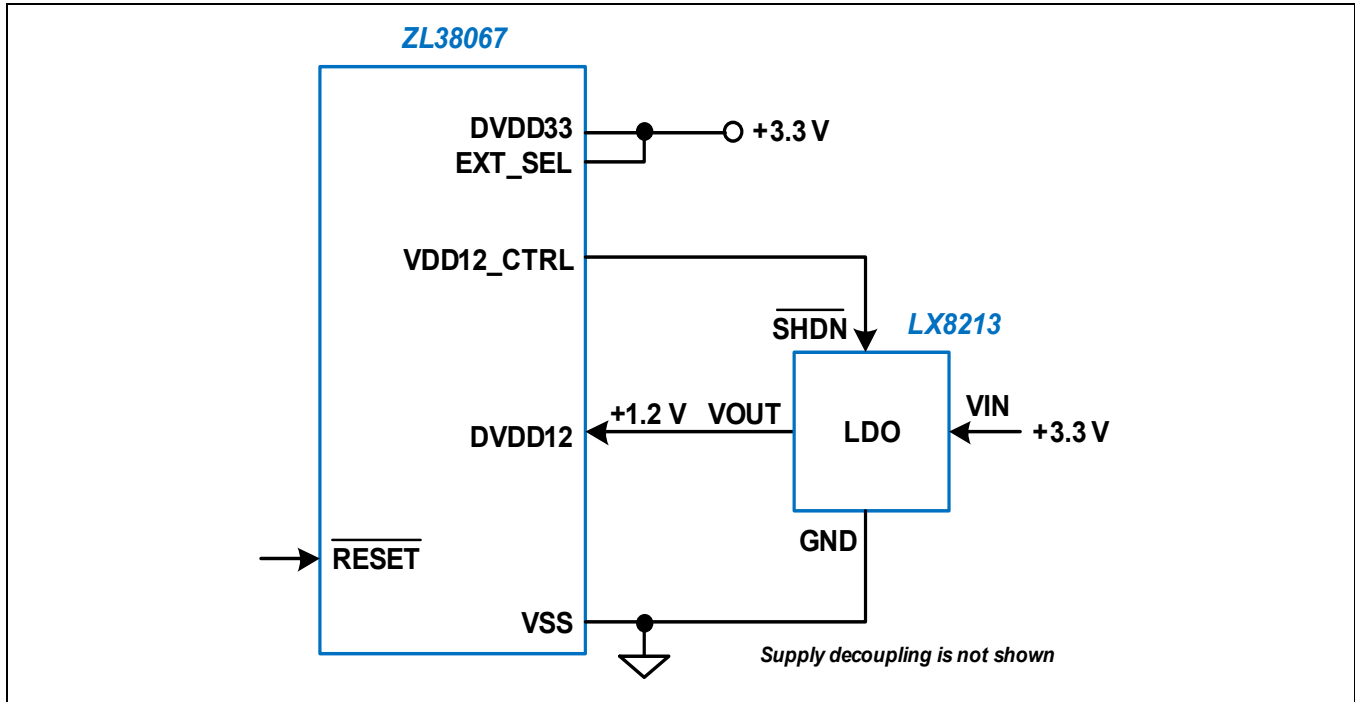

Figure 25 - External +1.2 V Power Supply Configuration

6.1.1.2 Internal +1.2 V Power

Note: The internal +1.2 V power option is only available with the 64-pin QFN package. The VDD12_CTRL pin is not available on the 56-ball WLCSP package.

Alternatively, the ZL38067 has a built-in voltage regulator that can be used as the DVDD12 source. The internal voltage regulator requires an external N-channel FET device and a parallel 470 ohm resistor. [Figure 26](#) shows DVDD12 powered from the internal supply. Power dissipation is higher with internal regulator use due to the internal control circuitry and functional blocks being active.

Internal supply use is selected when the EXT_SEL pin is tied to VSS. With the built-in voltage regulator enabled, VDD12_CTRL will drive Q1 and generate +1.2 V at DVDD12. The parallel 470 ohm resistor is required to ensure supply start-up. Q1 can be any of the high power FETs shown in [Table 5](#), or an equivalent.

For power savings when the ZL38067 does not need to be operational, the internal voltage regulator can be turned off by pulling the RESET pin low for longer than 10 μS (Reset mode). This action will force the VDD12_CTRL pin low, shutting off the FET and allowing the +1.2 V supply to collapse to 0 V.

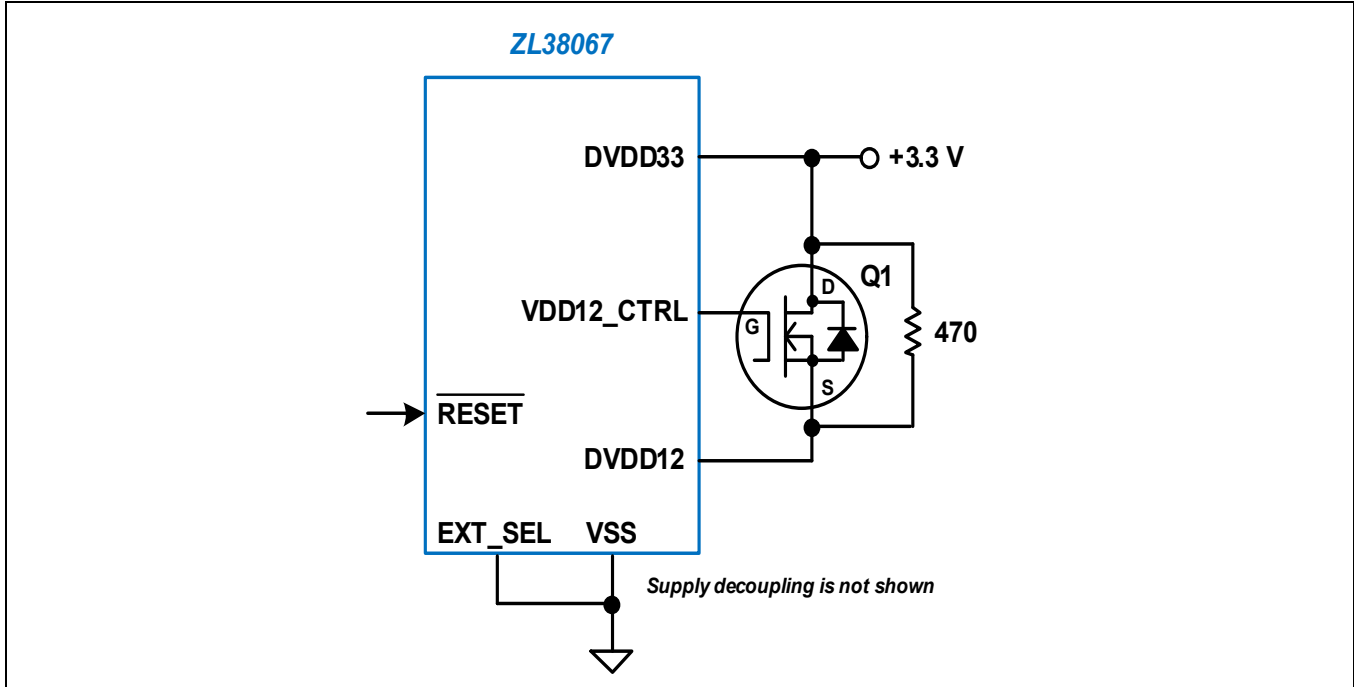

Figure 26 - Internal +1.2 V Power Supply Configuration

Table 5 - Q1 Component Options

Manufacturer	Part Number
Vishay®	Si1422DH
International Rectifier	IRLMS2002
Diodes Inc.®	ZXMN2B03E6

6.1.1.3 Ultra-Low Power Mode

Note: Ultra-low power mode is only available with the 64-pin QFN package. The DVDD33_XTAL pin is not available on the 56-ball WLCSP package.

The ZL38067 can be placed into an Ultra-low power state by turning off the crystal oscillator’s internal voltage regulator. The circuit required to perform this is shown in [Figure 27](#).

The external circuit that drives the ZL38067 $\overline{\text{RESET}}$ pin can also be used to power the DVDD33_XTAL pin. The reset drive circuit (gate) needs to provide at least 10 mA of source current when reset is high. The series 100 ohm resistor provides a time delay to keep crystal power from reacting to short reset pulses. When the reset line goes low for longer than 10 μS , the crystal oscillator’s internal regulator will turn off and the ZL38067 will draw Ultra-low power as specified in [“Device Operating Modes” on page 43](#).

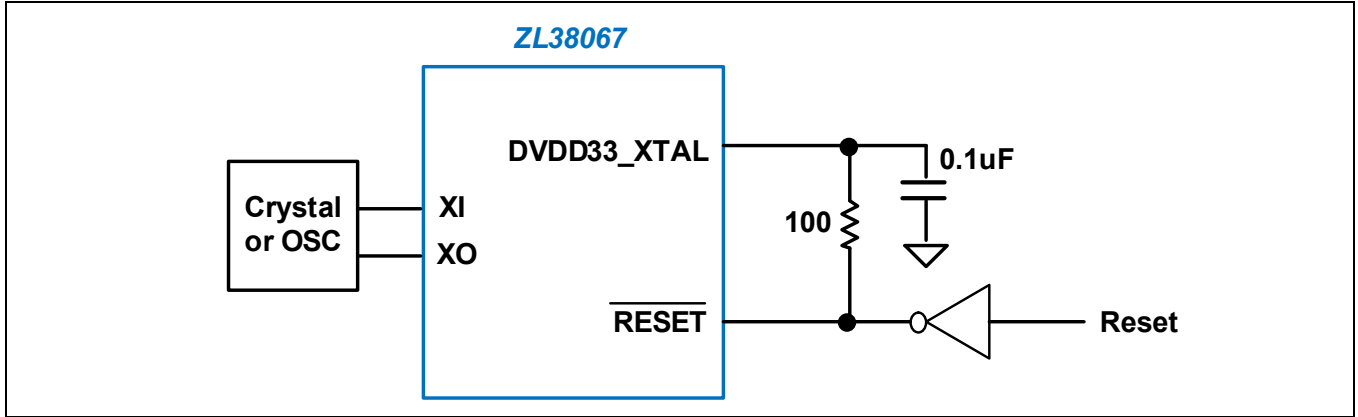

Figure 27 - Ultra-Low Power Operation Circuit

7.0 Device Booting and Firmware Swapping

7.1 Boot Loader

The ZL38067 device contains a built-in boot-loader that gets executed after a hardware reset, when power is initially applied to the part, and during the Firmware Swap process. The Bootloader performs the following actions:

- Reads the GPIO bootstrap information and stores it in the Boot Sense registers
- Determinant on the bootstrap setting, it loads external serial Flash device contents (firmware and configuration record) into Program RAM (Auto Boot), or waits for the host to load Program RAM (Host Boot and Firmware Swap)
- If Auto Boot is selected, the Bootloader then programs the ZL38067 configuration registers to their proper default values, and jumps to Program RAM to execute the firmware

7.2 Bootstrap Modes

[Table 6](#) lists the different boot options that can be selected by using external resistor. GPIOs have internal pull-down resistors, thereby defaulting to a 0 setting. A resistor to DVDD33 is required to select a 1 option. An external pull-up resistor must have a value of 3.3 K Ω . A GPIO with a bootstrap pull-up can be used for other functionality following the power-up boot sense process.

Table 6 - Bootstrap Modes

GPIO_2	GPIO_1	GPIO_0	Operating Mode	Description	Notes
X	0	0	Crystal source 12 MHz (default)	Clock source selection	
X	0	1	TDM FSA source is 8 kHz		1, 2
X	1	0	TDM FSA source is 16 kHz		1, 3
X	1	1	Reserved		
0	X	X	Host Boot (default)	Boot source selection	
1	X	X	Auto Boot from external flash		1, 4

X = Don't care.

Note 1: GPIO_[2:0] pins can have a pull-up resistor for bootstrap options. If a pull-up resistor is present and GPIO_[2:0] are used for keypad scanning, it is preferable to use GPIO_[2:0] as column lines to minimize power dissipation.

Note 2: Apply a 3.3 K Ω resistor from GPIO_0 to DVDD33.

Note 3: Apply a 3.3 K Ω resistor from GPIO_1 to DVDD33.

Note 4: Apply a 3.3 K Ω resistor from GPIO_2 to DVDD33. Note, when external flash is selected, GPIO_9 = SM_CS.

7.3 Loadable Device Code

In order for the ZL38067 to operate, it must be loaded with code that resides externally. This code can either be Auto Booted from an external Flash memory through the Master SPI, or can be loaded into the ZL38067 by the host processor through the HBI port. An external resistor pull-up or an internal resistor pull-down determines which boot mode will be used (see [Table 6](#)).

The external code consists of two logical segments, the firmware code itself and the configuration record. The firmware is a binary image which contains all of the executable code allowing the ZL38067 to perform voice processing and establishes the user command set. The configuration record contains settings for all of the user registers and defines the power-up operation of the device.

The configuration record is setup so that the registers are initialized to their desired values for normal operation.

A GUI development tool (*MiTuner*[™] ZLS38508) is provided to create and modify a configuration record and create a bootable Flash image which can then be duplicated for production of the end product. This tool requires access to the UART and to the I²S port for tuning (refer to [Section 12.0, "AEC Tuning" on page 61](#)).

7.3.1 Boot Speed

When performing an Auto Boot from a Flash device the boot sequence lasts <1 second (for a typical firmware image and configuration record of size 400kB, and a SPI clock speed of around 3.2MHz or higher).

When performing a Host Boot through the HBI SPI/I²C Slave port, the boot time will vary depending on the host's communications speed. SPI can run up to a speed of 25 MHz and has less overhead, allowing it to perform a boot download ~<300 ms; I²C is limited to a speed of 400 kHz, making a boot download last ~>5 seconds. If boot speed is important, use the HBI SPI Slave port (or Flash) for booting rather than the I²C Slave port.

7.4 Bootup Procedure

Valid clocks (crystal or clock oscillator) must be present before the ZL38067 device can exit its reset state. After the reset line is released, the ZL38067's internal voltage regulator will be enabled (if the EXT_SEL pin is strapped low). Once the +1.2 V supply is established, the PLL will be also be enabled. Based on GPIO_0 and GPIO_1 bootstrap settings being 0, the ZL38067 will select the system parameters and the PLL will lock to the crystal or clock oscillator 12.000 MHz operating frequency. An event will be placed in the event-queue and the interrupt pin (HINT) will be pulled low to signal the host when it's OK to load boot code.

Next, if the GPIO strapping pins indicate that the ZL38067 will Auto Boot, it will begin reading data from the external Flash. Refer to the *Microsemi AcuEdge*[™] *Technology ZLS38067 Firmware Manual* for a listing of the complete Boot Sequence.

If the GPIO strapping pins indicate that the ZL38067 will Host Boot, the SPI or I²C port that initiates the loading process becomes the boot master. The ZL38067 allows for automatic configuration between SPI and I²C operation. For the HBI port, if the HCLK toggles for two cycles, the HBI will default to the SPI Slave, otherwise it will remain configured as I²C.

8.0 Device Pinouts

8.1 64-Pin QFN

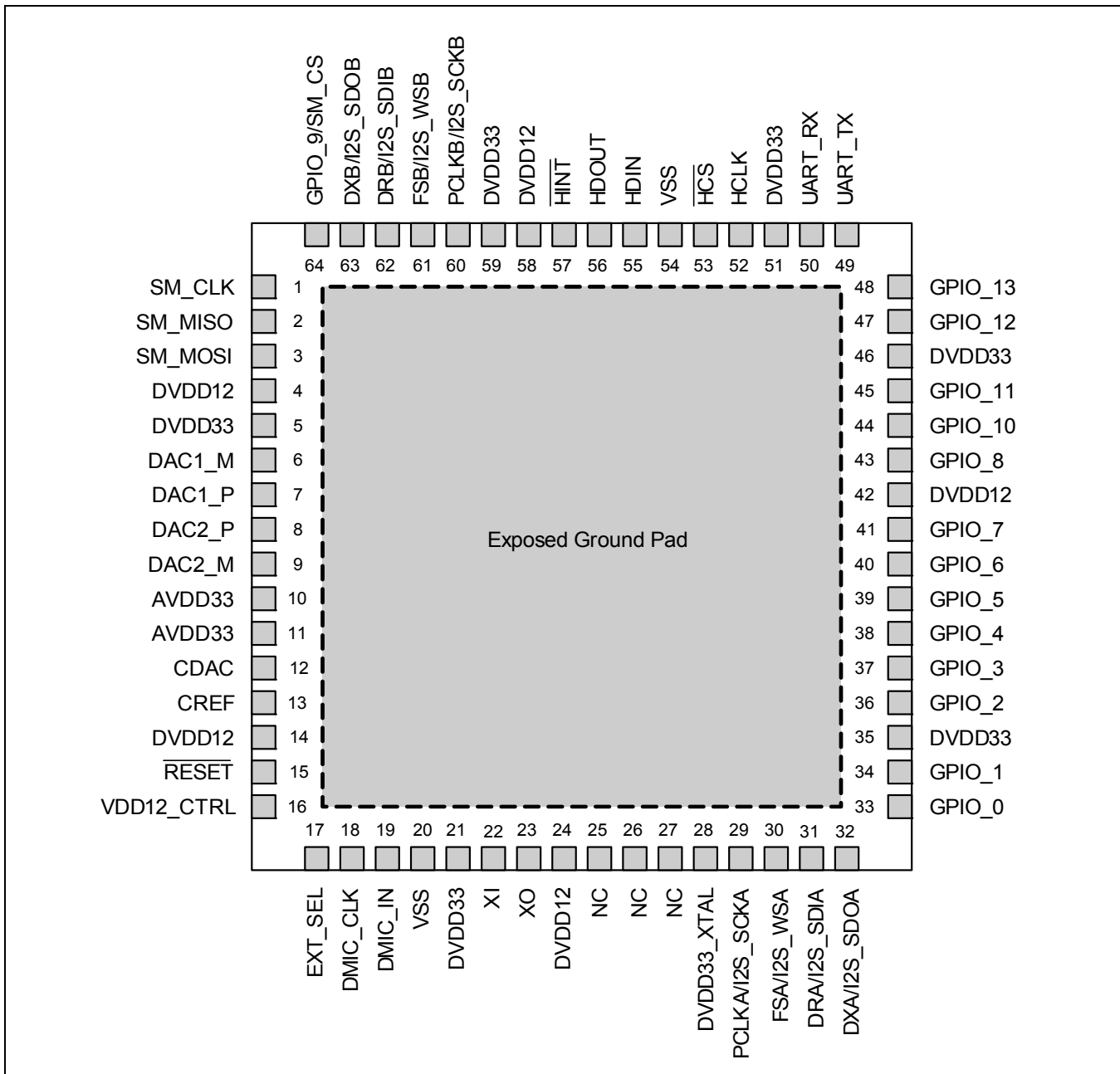
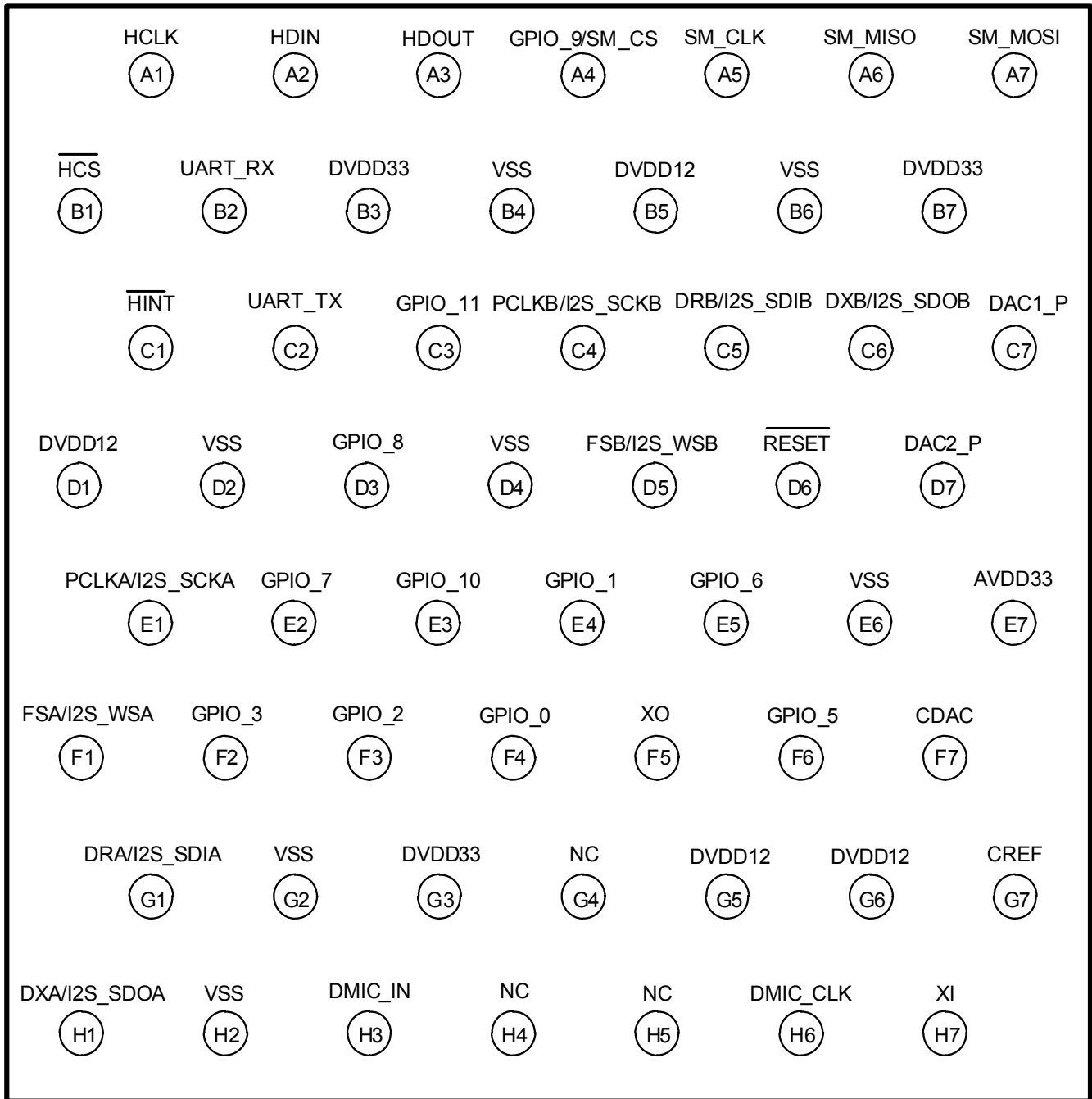

Figure 28 - ZL38067 64-Pin QFN – Top View

8.2 56-Ball WLCSP

Figure 29 - ZL38067 56-Ball WLCSP – Top View

9.0 Pin Descriptions

Table 7 - Reset Pin Description

QFN Pin #	WLCSP Ball	Name	Type	Description
15	D6	$\overline{\text{RESET}}$	Input	<p>Reset. When low the device is in its reset state and all tristate outputs will be in a high impedance state. This input must be high for normal device operation.</p> <p><i>A 10 KΩ pull-up resistor is required on this pin to DVDD33 if this pin is not continuously driven.</i></p> <p>Refer to “Reset” on page 26 for an explanation of the various reset states and their timing.</p>

Table 8 - DAC Pin Descriptions

QFN Pin #	WLCSP Ball	Name	Type	Description
6	–	DAC1_M	Output	<p>DAC 1 Minus Output. This is the negative output signal of the differential amplifier of DAC 1. Pin functionality is firmware dependent.</p> <p><i>Not available on the WLCSP package.</i></p>
7	C7	DAC1_P	Output	<p>DAC 1 Plus Output. This is the positive output signal of the differential amplifier of DAC 1. Pin functionality is firmware dependent.</p>
9	–	DAC2_M	Output	<p>DAC 2 Minus Output. This is the negative output signal of the differential amplifier of DAC 2. Pin functionality is firmware dependent.</p> <p><i>Not available on the WLCSP package.</i></p>
8	D7	DAC2_P	Output	<p>DAC 2 Plus Output. This is the positive output signal of the differential amplifier of DAC 2. Pin functionality is firmware dependent.</p>
12	F7	CDAC	Output	<p>DAC Reference. This pin may require capacitive decoupling. Refer to “DAC Output - Full Duplex Communication Mode (ZLS38067.0)” on page 12.</p>
13	G7	CREF	Output	<p>Common Mode Reference. This pin requires capacitive decoupling. Refer to “DAC Output - Full Duplex Communication Mode (ZLS38067.0)” on page 12.</p>

Table 9 - Microphone Pin Descriptions

QFN Pin #	WLCSP Ball	Name	Type	Description
18	H6	DMIC_CLK	Output	Digital Microphone Clock Output. Clock output for digital microphones and digital electret microphone pre-amplifier devices.
19	H3	DMIC_IN	Input	Digital Microphone Input. Stereo or mono digital microphone input. Accommodates MIC 1 and MIC 2. <i>Tie to VSS if unused.</i>

Table 10 - TDM and I²S Ports Pin Descriptions

All of these pins are only functional with Full Duplex Communication Firmware (ZLS38067.0).

The firmware supports two TDM interfaces, TDM-A and TDM-B. Each TDM block is capable of being a master or a slave. The ports can be configured for Pulse-Code Modulation (PCM) or Inter-IC Sound (I²S) operation. The ports conform to PCM, GCI, and I²S timing protocols.

QFN Pin #	WLCSP Ball	Name	Type	Description
29	E1	PCLKA/ I2S_SCKA	Input/ Output	<p>PCM Port A Clock (Input/Tristate Output). PCLKA is equal to the bit rate of signals DRA/DXA. In TDM master mode this clock is an output and in TDM slave mode this clock is an input.</p> <p>I²S Port A Serial Clock (Input/Tristate Output). This is the I²S port A bit clock. In I²S master mode this clock is an output and drives the bit clock input of the external slave device's peripheral converters. In I²S slave mode this clock is an input and is driven from a converter operating in master mode.</p> <p>After power-up, this signal defaults to be an input in I²S slave mode.</p> <p><i>A 100 KΩ pull-down resistor is required on this pin to VSS. If this pin is unused, tie the pin to VSS.</i></p> <p><i>When driving PCLKA/I2S_SCKA from a host, one of the following conditions must be satisfied:</i></p> <ol style="list-style-type: none"> <i>Host drives PCLKA low during reset, or</i> <i>Host tri-states PCLKA during reset (the 100 KΩ resistor will keep PCLKA low), or</i> <i>Host drives PCLKA at its normal frequency</i>

QFN Pin #	WLCSP Ball	Name	Type	Description
30	F1	FSA/ I2S_WSA	Input/ Output	<p>CM Port A Frame Sync (Input/Tristate Output). This is the TDM frame alignment reference. This signal is an input for applications where the PCM bus is frame aligned to an external frame signal (slave mode). In master mode this signal is a frame pulse output.</p> <p>I²S Port A Word Select (Left/Right) (Input/Tristate Output). This is the I²S port A left or right word select. In I²S master mode word select is an output which drives the left/right input of the external slave device's peripheral converters. In I²S slave mode this pin is an input which is driven from a converter operating in master mode.</p> <p>After power-up, this signal defaults to be an input in I²S slave mode. <i>Tie this pin to VSS if unused.</i></p>
31	G1	DRA/ I2S_SDIA	Input	<p>PCM Port A Serial Data Stream Input. This serial data stream operates at PCLK data rates.</p> <p>I²S Port A Serial Data Input. This is the I²S port serial data input.</p> <p><i>Tie this pin to VSS if unused.</i></p>
32	H1	DXA/ I2S_SDOA	Output	<p>PCM Port A Serial Data Stream Output. This serial data stream operates at PCLK data rates.</p> <p>I²S Port A Serial Data Output. This is the I²S port serial data output.</p>
60	C4	PCLKB/ I2S_SCKB	Input/ Output	<p>PCM Port B Clock (Input/Tristate Output). PCLKB is equal to the bit rate of signals DRB/DXB. In TDM master mode this clock is an output and in TDM slave mode this clock is an input.</p> <p>I²S Port B Serial Clock (Input/Tristate Output). This is the I²S port B bit clock. In I²S master mode this clock is an output and drives the bit clock input of the external slave device's peripheral converters. In I²S slave mode this clock is an input and is driven from a converter operating in master mode.</p> <p>After power-up, this signal is an input in I²S slave mode. <i>Tie this pin to VSS if unused.</i></p>
61	D5	FSB/ I2S_WSB	Input/ Output	<p>PCM Port B Frame Sync (Input/Tristate Output). This is the TDM frame alignment reference. This signal is an input for applications where the PCM bus is frame aligned to an external frame signal (slave mode). In master mode this signal is a frame pulse output.</p> <p>I²S Port B Word Select (Left/Right) (Input/Tristate Output). This is the I²S port B left or right word select. In I²S master mode word select is an output which drives the left/right input of the external slave device's peripheral converters. In I²S slave mode this pin is an input which is driven from a converter operating in master mode.</p> <p>After power-up, this signal defaults to be an input in I²S slave mode. <i>Tie this pin to VSS if unused.</i></p>

QFN Pin #	WLCSP Ball	Name	Type	Description
62	C5	DRB/ I2S_SDIB	Input	<p>PCM Port B Serial Data Stream Input. This serial data stream operates at PCLK data rates.</p> <p>I²S Port B Serial Data Input. This is the I²S port serial data input.</p> <p><i>Tie this pin to VSS if unused.</i></p>
63	C6	DXB/ I2S_SDOB	Output	<p>PCM Port B Serial Data Stream Output. This serial data stream operates at PCLK data rates.</p> <p>I²S Port B Serial Data Output. This is the I²S port serial data output.</p>

Table 11 - HBI – SPI Slave Port Pin Descriptions

This port functions as a peripheral interface for an external controller, and supports access to the internal registers and memory of the device.

QFN Pin #	WLCSP Ball	Name	Type	Description
52	A1	HCLK	Input	<p>HBI SPI Slave Port Clock Input. Clock input for the SPI Slave port. Maximum frequency = 25 MHz.</p> <p>This input should be tied to VSS in I²C mode, refer to Table 2.</p> <p><i>Tie this pin to VSS if unused.</i></p>
53	B1	$\overline{\text{HCS}}$	Input	<p>HBI SPI Slave Chip Select Input. This active low chip select signal activates the SPI Slave port.</p> <p>HBI I²C Serial Clock Input. This pin functions as the I2C_SCLK input in I²C mode. <i>A pull-up resistor is required on this node for I²C operation.</i></p> <p><i>Tie this pin to VSS if unused.</i></p>
55	A2	HDIN	Input	<p>HBI SPI Slave Port Data Input. Data input signal for the SPI Slave port.</p> <p>This input selects the slave address in I²C mode, refer to Table 2.</p> <p><i>Tie this pin to VSS if unused.</i></p>
56	A3	HDOUT	Input/ Output	<p>HBI SPI Slave Port Data Output (Tristate Output). Data output signal for the SPI Slave port.</p> <p>HBI I²C Serial Data (Input/Output). This pin functions as the I2C_SDA I/O in I²C mode. <i>A pull-up resistor is required on this node for I²C operation.</i></p>
57	C1	$\overline{\text{HINT}}$	Output	<p>HBI Interrupt Output. This output can be configured as either CMOS or open drain by the host.</p>

Table 12 - Master SPI Port Pin Descriptions

This port functions as the interface to an external Flash device used to optionally Auto Boot and load the device's firmware and configuration record from external Flash memory.

QFN Pin #	WLCSP Ball	Name	Type	Description
1	A5	SM_CLK	Output	Master SPI Port Clock (Tristate Output). Clock output for the Master SPI port. Maximum frequency = 8 MHz.
2	A6	SM_MISO	Input	Master SPI Port Data Input. Data input signal for the Master SPI port.
3	A7	SM_MOSI	Output	Master SPI Port Data Output (Tristate Output). Data output signal for the Master SPI port.
64	A4	GPIO_9/ SM_CS	Input/ Output	Master SPI Port Chip Select (Input Internal Pull-Up/Tristate Output). Chip select output for the Master SPI port. Shared with GPIO_9, see Table 15 .

Table 13 - Oscillator Pin Descriptions

These pins are connected to a 12.000 MHz crystal or clock oscillator which drives the device's internal PLL.

QFN Pin #	WLCSP Ball	Name	Type	Description
22	H7	XI	Input	Crystal Oscillator Input. Refer to "External Clock Requirements" on page 48 .
23	F5	XO	Output	Crystal Oscillator Output. Refer to "External Clock Requirements" on page 48 .

Table 14 - UART Pin Descriptions

The ZL38067 device incorporates a two-wire UART (Universal Asynchronous Receiver Transmitter) interface with a fixed 115.2K baud transfer rate, 8 data bits, 1 stop and no parity. The UART port can be used as a debug tool and is used for tuning purposes.

QFN Pin #	WLCSP Ball	Name	Type	Description
50	B2	UART_RX	Input	UART (Input). Receive serial data in. This port functions as a peripheral interface for an external controller and supports access to the internal registers and memory of the device.
49	C2	UART_TX	Output	UART (Tristate Output). Transmit serial data out. This port functions as a peripheral interface for an external controller and supports access to the internal registers and memory of the device.

Table 15 - GPIO Pin Descriptions

GPIO ports can be used for interrupt and event reporting, fixed function control, bootstrap options, as well as being used for general purpose I/O for communication and controlling external devices. Pin functionality is firmware dependent.

QFN Pin #	WLCSP Ball	Name	Type	Description
33,34	F4, E4	GPIO_[0:1]	Input/Output	General Purpose I/O (Input Internal Pull-Down/Tristate Output). These pins can be configured as an input or output and are intended for low-frequency signalling. They must be pulled low or left floating when coming out of reset.
36	F3	GPIO_2	Input/Output	General Purpose I/O (Input Internal Pull-Down/Tristate Output). These pins can be configured as an input or output and are intended for low-frequency signalling. Refer to Table 6 for bootstrap functionality.
37,38 39,40, 41,43	F2, –, F6, E5, E2, D3	GPIO_[3:8]	Input/Output	General Purpose I/O (Input Internal Pull-Down/Tristate Output). These pins can be configured as an input or output and are intended for low-frequency signalling.
64	A4	GPIO_9/ SM_CS	Input/Output	General Purpose I/O (Input Internal Pull-Down/Tristate Output). This pin can be configured as an input or output and is intended for low-frequency signalling. Alternate functionality with SM_CS, see Table 12 .
44,45, 47,48	E3, C3, –, –	GPIO_ [10:13]	Input/Output	General Purpose I/O (Input Internal Pull-Down/Tristate Output). These pins can be configured as an input or output and are intended for low-frequency signalling. <i>GPIO_12 and GPIO_13 are not available on the WLCSP package.</i>

Table 16 - Supply and Ground Pin Descriptions

QFN Pin #	WLCSP Ball	Name	Type	Description
17	–	EXT_SEL	Input	VDD +1.2 V Select. Select external +1.2 V supply. Tie to DVDD33 if the +1.2 V supply is to be provided externally. Tie to VSS (0 V) if the +1.2 V supply is to be generated internally. Refer to 6.1.1, “Power Supply Considerations” for more information. <i>Not available on the WLCSP package.</i>
16	–	VDD12_CTRL	Output	VDD +1.2 V Control. Analog control line for the voltage regulator external FET when EXT_SEL is tied to VSS. When EXT_SEL is tied to DVDD33, the VDD12_CTRL pin becomes a CMOS output which can drive the shutdown input of an external LDO. Refer to 6.1.1, “Power Supply Considerations” for more information. <i>Not available on the WLCSP package.</i>
4, 14, 24, 42, 58	B5, D1, G5, G6	DVDD12	Power	Core Supply. Connect to a +1.2 V ±5% supply. <i>Place a 100 nF, 20%, 10 V, ceramic capacitor on each pin decoupled to the VSS plane.</i> Refer to 6.1.1, “Power Supply Considerations” for more information.
5, 21, 35, 46, 51, 59	B3, B7, G3	DVDD33	Power	Digital Supply. Connect to a +3.3 V ±5% supply. <i>Place a 100 nF, 20%, 10 V, ceramic capacitor on each pin decoupled to the VSS plane.</i>

QFN Pin #	WLCSP Ball	Name	Type	Description
28	–	DVDD33_XTAL	Power	Crystal Digital Supply. This pin must be connected to a +3.3 V supply source capable of delivering 10 mA. <i>Not available on the WLCSP package.</i>
10,11	E7	AVDD33	Power	Analog Supply. Connect to a +3.3 V $\pm 5\%$ supply. <i>Place a 100 nF, 20%, 10 V, ceramic capacitor on each pin decoupled to the VSS plane.</i>
20, 54	B4, B6, D2, D4, E6, G2, H2	VSS	Ground	Ground. Connect to digital ground plane.
	–	Exposed Ground Pad	Ground	Exposed Pad Substrate Connection. Connect to VSS. This pad is at ground potential and must be soldered to the printed circuit board and connected via multiple vias to a heatsink area on the bottom of the board and to the internal ground plane. <i>Not available on the WLCSP package.</i>

Table 17 - No Connect Pin Description

QFN Pin #	WLCSP Ball	Name	Type	Description
25, 26, 27	G4, H4, H5	NC		No Connection. These pins are to be left unconnected, do not use as a tie point.

10.0 Electrical Characteristics

10.1 Absolute Maximum Ratings

Stresses above those listed under *Absolute Maximum Ratings* can cause permanent device failure. Functionality at or above these limits is not implied. Exposure to absolute maximum ratings for extended periods may affect device reliability.

Supply voltage (DVDD33, AVDD33)	-0.5 to +4.0 V
Core supply voltage (DVDD12)	-0.5 to +1.32 V
Input voltage	-0.5 to +4.0 V
Continuous current at digital outputs	15 mA
Reflow temperature, 10 sec., MSL3, per <i>JEDEC J-STD-020</i>	260 °C
Storage temperature	-55 to +125 °C
ESD immunity (Human Body Model)	JESD22 Class 1C compliant

10.2 Thermal Resistance

Junction to ambient thermal resistance ⁽¹⁾ , θ_{JA}	64-pin QFN	°C/W
	56-ball WLCSP	°C/W
Junction to board thermal resistance ⁽¹⁾ , θ_{JB}	64-pin QFN	°C/W
	56-ball WLCSP	°C/W
Junction to exposed pad thermal resistance ⁽¹⁾ , θ_{JC}	64-pin QFN	°C/W
Junction to case thermal resistance ⁽¹⁾ , θ_{JC}	56-ball WLCSP	°C/W
Junction to top characterization parameter, ψ_{JT}	64-pin QFN	0.1 °C/W
	56-ball WLCSP	°C/W

Notes:

1. The thermal specifications assume that the device is mounted on an effective thermal conductivity test board (4 layers, 2s2p) per *JEDEC JESD51-7* and *JESD51-5*.

10.3 Operating Ranges

Microsemi guarantees the performance of this device over the industrial (-40 °C to 85 °C) temperature range by conducting electrical characterization over each range and by conducting a production test with single insertion coupled to periodic sampling. These characterization and test procedures comply with the *Telcordia GR-357-CORE Generic Requirements for Assuring the Reliability of Components Used in Telecommunications Equipment*.

Parameter	Symbol	Min.	Typ.	Max.	Units
Ambient temperature	T_A	-40		+85	°C
Analog supply voltage	V_{AVDD33}	3.135	3.3	3.465	V
Digital supply voltage	V_{DVDD33}				
Crystal Digital supply voltage	V_{DVDD33_XTAL}				
Crystal I/O voltage	V_{XI}		2.5	2.625	V
Core supply voltage	V_{DVDD12}	1.14	1.2	1.26	V

10.4 Device Operating Modes

When the full duplex communication firmware (ZL38067.0) or the barge-in firmware (ZL38067.2) is running, the ZL38067 is considered to be in normal operating mode.

Low-power and sleep modes are firmware programmable options. Reset and Ultra-low power modes are hardware modes that can be utilized to minimize power consumption for all the firmware variants.

Operating modes are highlighted in the following sections. Refer to the *Microsemi AcuEdge™ Technology ZLS38067 Firmware Manual* for programming and additional information on the firmware operating modes.

10.4.1 Normal

- Normal firmware mode
- HBI active
- Audio path active, wideband (16KHz) or narrowband (8KHz) operation *Note: ASR requires wideband operation.*
- DACs and MICs can be enabled
- Audio Processor always on

Normal mode is recommended for applications that use the internal voltage regulator with analog microphones. Normal mode keeps the Audio Processor always on, thereby minimizing +1.2 V power supply noise that could be injected into sensitive analog microphone circuitry via the board layout.

10.4.2 Low-Power

- Low-Power firmware mode
- HBI active
- Audio path active, wideband or narrowband operation
- DACs and MICs can be enabled
- Audio Processor operates in Power Saving Mode

Low-power mode is selected in register 0x206 (System Control Flags) bit 1, or can be selected from the ZLS38508 *MiTuner™* GUI in the AEC Control window (Enable Power Saving Mode). Low-Power mode is not recommended for applications that use the internal voltage regulator with analog microphones.

10.4.3 Sleep

- Sleep firmware mode
- HBI active
- Audio path inactive
- DACs and MICs are powered down
- Audio Processor made inactive, internal clocks are shutdown, requires a wake-up procedure to return to Normal or Low-Power mode. *Note: ASR not enabled in Sleep Mode.*

The ZL38067 will respond to no other inputs until it awakens from Sleep mode. To wake from Sleep mode, perform an HBI Wake From Sleep operation, as described in the *ZLS38067 Firmware Manual* Appendix D. The firmware and configuration records loaded into the device RAM are retained, no re-boot is required.

10.4.4 Reset

- Hardware mode, the ZL38067 goes into this mode when the $\overline{\text{RESET}}$ pin is held low for greater than 10 μS

- HBI inactive
- Audio path inactive
- DACs and MICs are powered down
- Audio Processor powered down via removal of +1.2 V supply

See [Section 5.0, “Reset” on page 26](#) for more information and refer to [Section 6.0, “Power Supply” on page 27](#) for information on +1.2 V removal.

10.4.5 Ultra-Low Power

- Hardware mode, the hardware can be configured to enter this mode when the $\overline{\text{RESET}}$ pin is held low for greater than 10 μS
- HBI inactive
- Audio path inactive
- DACs and MICs are powered down
- Audio Processor powered down via removal of +1.2 V supply
- Crystal or clock oscillator supply made inactive

See [Section 5.0, “Reset” on page 26](#) and [Section 6.1.1.3, “Ultra-Low Power Mode” on page 29](#) for more information, refer to [Section 6.0, “Power Supply” on page 27](#) for information on +1.2 V removal.

10.4.6 Current Consumption

Device current consumption can vary with the firmware load. Common values are listed here using an external +1.2 V supply for the core power supply with a 12.000 MHz crystal and a 3.3 K Ω resistor from GPIO_2 to DVDD33 (external Flash selected), unless otherwise noted.

Operational Mode (Firmware Variant)	+3.3 V ¹		+1.2 V ²		Units	Notes / Conditions
	Typ.	Max.	Typ.	Max.		
Normal Wideband Narrowband ⁶	10		130		mA	Firmware active, power-saving off, 1 DAC active ³ , 1 or 2 MICs active ⁴ , LEC bypassed, HBI is active.
	8		83			
Low-Power Wideband Narrowband ⁶	10		90			
	8		60			
Sleep	2		12			Firmware inactive (Firmware and configuration record are retained), DACs and MICs are powered down, HBI is active.
Reset	100		n/a		μ A	Device in reset (reset > 10 μ S), DVDD12 removed ⁵ .
Ultra-Low Power	3		n/a			Device in reset (reset > 10 μ S), DVDD12 not present, DVDD33_XTAL held low.

Note 1: Table values include all current entering DVDD33, AVDD33, and DVDD33_XTAL pins.
Add 1.0 mA to Normal, Low-Power, and Sleep modes if the internal voltage regulator is used (EXT_SEL = VSS).

Note 2: Core supply voltage. Table values include all current entering DVDD12 pins.

Note 3: DAC in differential mode, for 2 DACs active in differential mode, add 3.6 mA to +3.3 V current.

Note 4: DMIC_IN active.

Note 5: DVDD12 is removed if the internal regulator is used for +1.2 V generation or if the VDD12_CTRL pin is used to shutdown an external +1.2 V LDO that provides DVDD12 to the ZL38067.

Note 6: Narrowband (8KHz) mode only available in ZLS38067.0 firmware.

10.5 DC Specifications

Typical values are for $T_A = 25\text{ }^\circ\text{C}$ and nominal supply voltage. Minimum and maximum values are over the industrial $-40\text{ }^\circ\text{C}$ to $85\text{ }^\circ\text{C}$ temperature range and supply voltage range as shown in [“Operating Ranges” on page 42](#), except as noted. A 12.000 MHz clock oscillator is active.

Parameter	Symbol	Min.	Typ.	Max.	Units	Notes / Conditions
Input high voltage	V_{IH}	0.7 * V_{DVDD33}		$V_{DVDD33} + 0.3$	V	All digital inputs
Input low voltage	V_{IL}	$V_{VSS} - 0.3$		0.3 * V_{DVDD33}	V	All digital inputs
Input hysteresis voltage	V_{HYS}	0.4			V	
Input leakage (input pins)	I_{IL}			5	μA	0 to +3.3 V
Input leakage (bi-directional pins)	I_{BL}			5	μA	0 to +3.3 V
Weak pull-up current	I_{PU}	38	63	101	μA	Input at 0 V
Weak pull-down current	I_{PD}	19	41	158	μA	Input at +3.3 V
Input pin capacitance	C_I		5		pF	
Output high voltage	V_{OH}	2.4			V	At 12 mA
Output low voltage	V_{OL}			0.4	V	At 12 mA
Output high impedance leakage	I_{OZ}			5	μA	0 to +3.3 V
Pin capacitance (output & input/tristate pins)	C_O		5		pF	
Output rise time	t_{RT}		1.25		ns	10% to 90%, $C_{LOAD} = 20\text{ pF}$
Output fall time	t_{FT}		1.25		ns	90% to 10%, $C_{LOAD} = 20\text{ pF}$

10.6 AC Specifications

For all AC specifications, typical values are for $T_A = 25\text{ }^\circ\text{C}$ and nominal supply voltage. Minimum and maximum values are over the industrial $-40\text{ }^\circ\text{C}$ to $85\text{ }^\circ\text{C}$ temperature range and supply voltage ranges as shown in [“Operating Ranges” on page 42](#), except as noted. A 12.000 MHz clock oscillator is active with Full Duplex Communication Firmware in Normal, Wideband operational mode.

10.6.1 Microphone Interface

Parameter	Symbol	Min.	Typ.	Max.	Units	Notes / Conditions
Microphone clock output (DMIC_CLK), 8 kHz, 16 kHz sample rate 48 kHz sample rate			1.024 3.072		MHz MHz	
DMIC_CLK, Output high current	I_{OH}		20		mA	$V_{OH} = DVDD33 - 0.4\text{ V}$
DMIC_CLK, Output low current	I_{OL}		30		mA	$V_{OL} = 0.4\text{ V}$
DMIC_CLK, Output rise and fall time	t_R, t_F		5		ns	$C_{LOAD} = 100\text{ pF}$

10.6.2 DAC

Measurements taken using PCM mode. THD+N versus output power for speaker drive applications presented in [Figure 30](#); THD+N versus output voltage for amplifier drive applications presented in [Figure 31](#).

Parameter	Symbol	Min.	Typ.	Max.	Units	Notes / Conditions
DAC output level: Full scale: Differential Single-ended 0 dBm0 : Differential Single-ended	V_{DACFS}		4.8 2.4 2.8 1.4		V_{PP}	DAC gain = 1, 1 K Ω load.
PCM full scale level (V_{ppd} value)			9		dBm0	DAC gain = 1, 600 Ω load
DAC output power: Single-ended, 32 ohm load Single-ended, 16 ohm load Differential, 32 ohm load			20.6 37.5 86.0	24 47 94	mW	1, Single-ended loads driven capacitively to ground
Frequency response: Sample rate = 48 kS/s	f_R	20		20000	Hz	1, 3 dB cutoff includes external AC coupling, without AC coupling the response is low pass.
Dynamic range: Sample rate = 48 kS/s			92		dBFS	20 Hz - 20 kHz
Total harmonic distortion plus noise	THD + N		-82		dBFS	2, Input = -3 dBFS.
Signal to Noise Ratio	SNR		85		dB	2, 1004 Hz, C-message weighted
Allowable capacitive load to ground	C_L			100	pF	1, At each DAC output.
Power supply rejection ratio	PSRR	50	70		dB	1, 20 Hz - 100 kHz, 100 mVpp supply noise.
Crosstalk			-85	-70	dB	1, Between DAC outputs.
Note 1: Guaranteed by design, not tested in production.						
Note 2: Single-ended or differential output.						

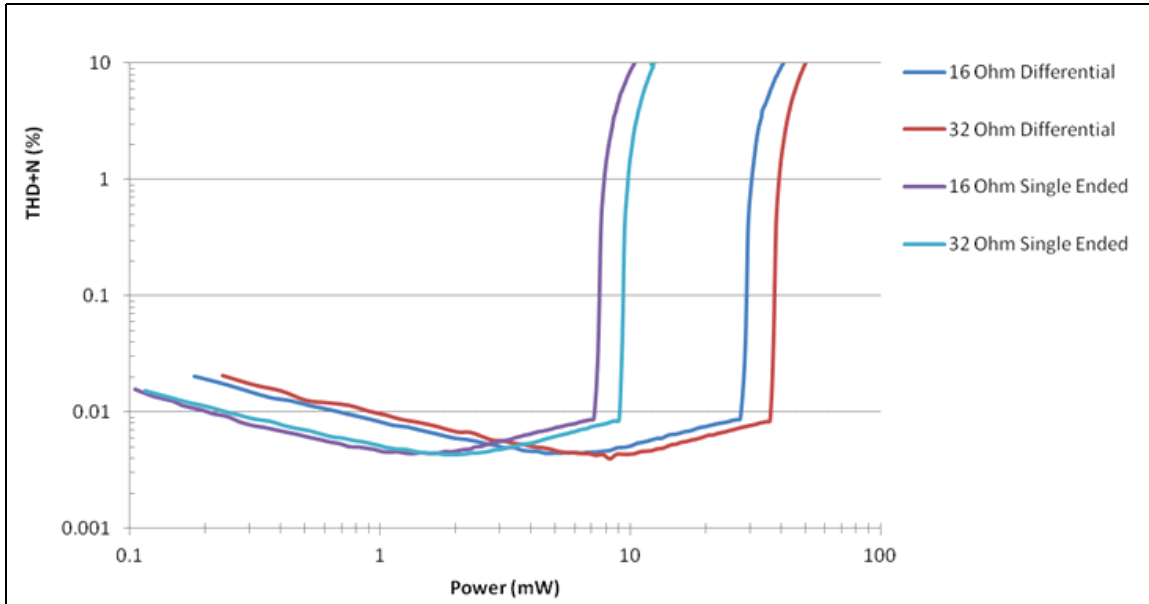

Figure 30 - THD+N Ratio versus Output Power – Driving Low Impedance

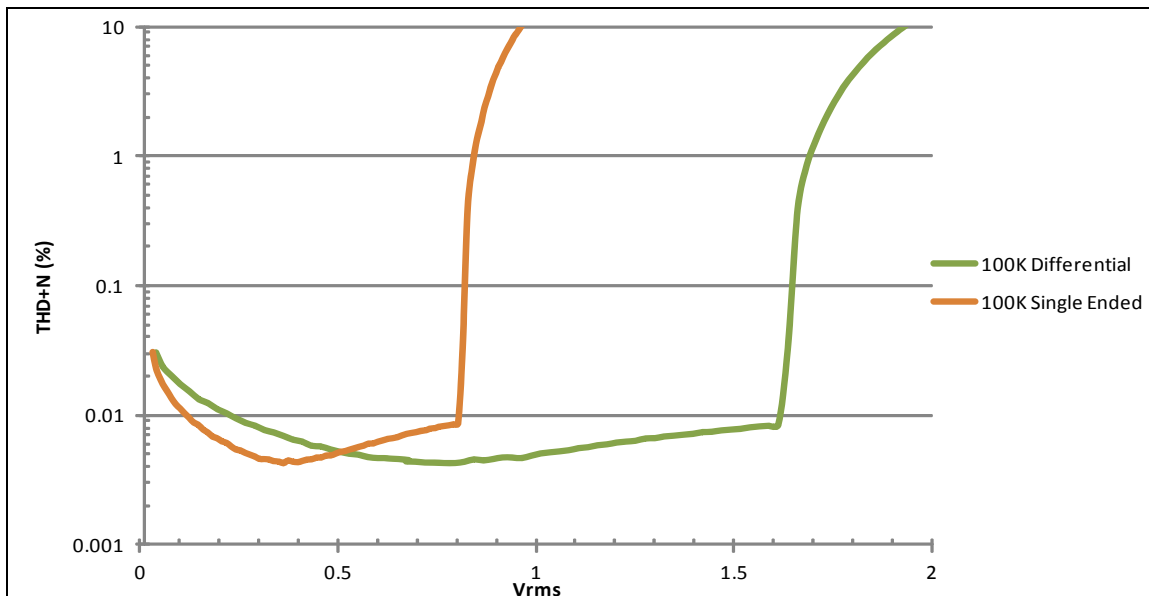

Figure 31 - THD+N Ratio versus V_{RMS} – Driving High Impedance

10.7 External Clock Requirements

In all modes of operation the ZL38067 requires an external clock source. The external clock drives the device's internal PLL which is the source for the internal timing signals.

The external clock source can either be:

- 12.000 MHz crystal, or
- 12.000 MHz clock oscillator with a 2.5 V output

The following three sections discuss these options.

10.7.1 Crystal Application

The oscillator circuit that is created across pins XI and XO requires an external fundamental mode crystal that has a specified parallel resonance (f_p) at 12.000 MHz.

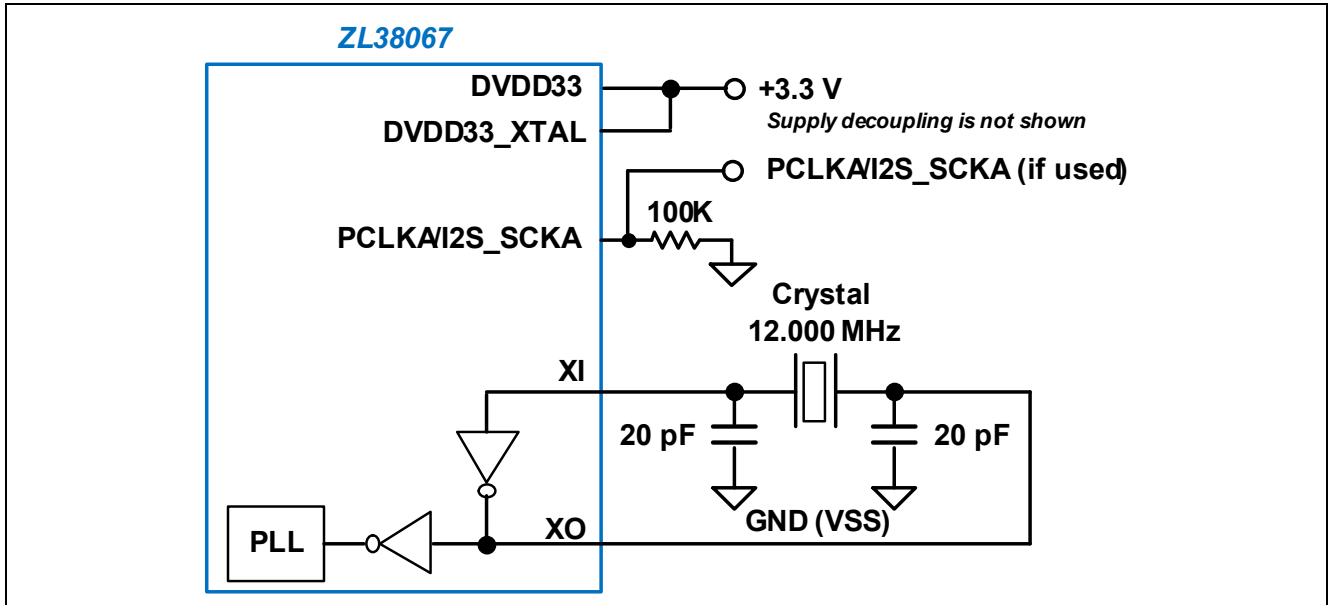

Figure 32 - Crystal Application Circuit

10.7.2 Clock Oscillator Application

Figure 33 illustrates the circuit that is used when the ZL38067 external clock source is a clock oscillator. The oscillator pins are 2.5 V compliant and should not be driven from 3.3 V CMOS without a level shifter or voltage attenuator.

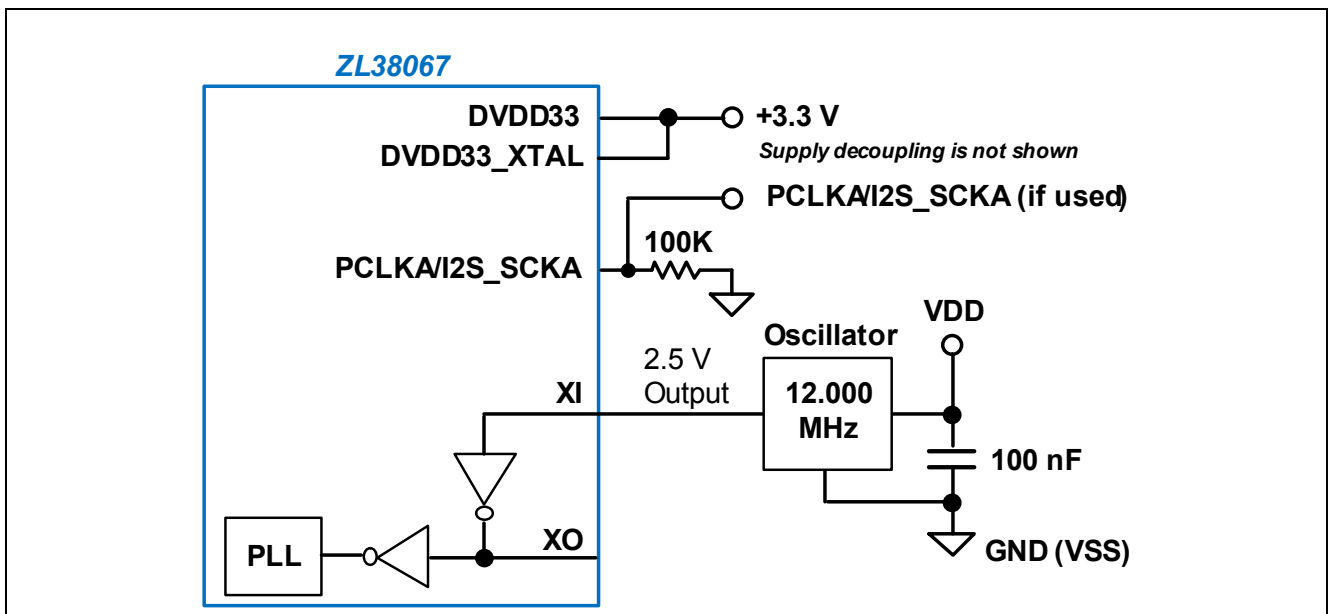

Figure 33 - Clock Oscillator Application Circuit

10.7.3 PCLKA (Crystal-less) Application

Figure 34 illustrates how to configure the ZL38067 for crystal-less operation. PCLKA is used as the PLL clock source. PCLKA must be set at a frequency of 2.048, 4.096, or 8.192 MHz. Since the crystal circuit is not used, the DVDD33_XTAL pin can be grounded to VSS to save power. When using crystal-less application, GPIO_0 or GPIO_1 must be pulled high to set the sample rate and the PCLKA must be active all the time. For more information, refer to [Section 7.2, “Bootstrap Modes” on page 31](#).

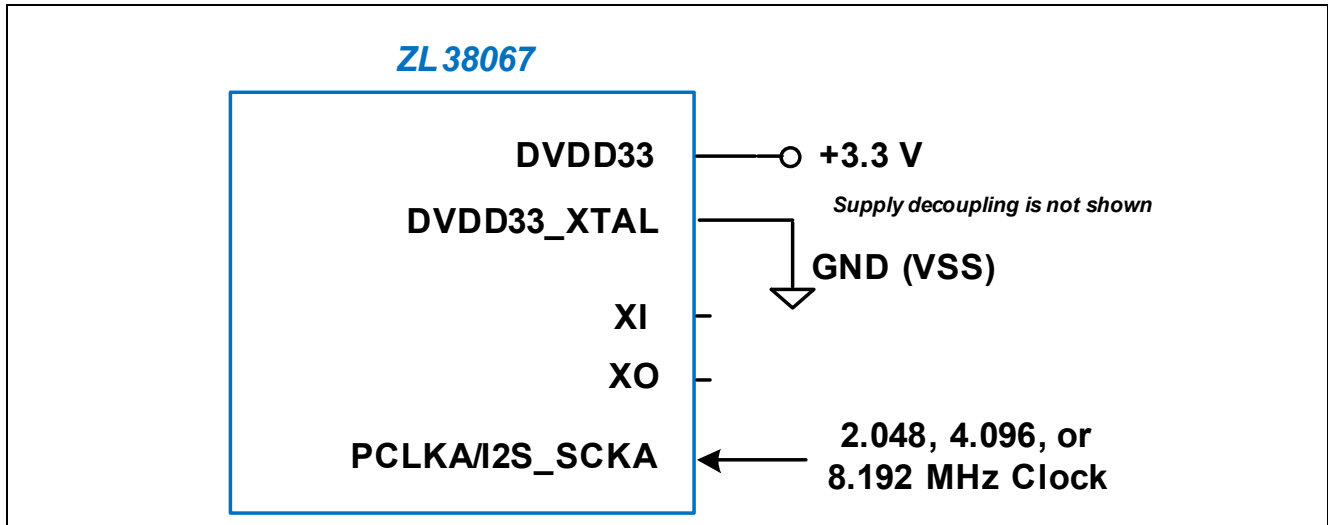

Figure 34 - Crystal-less Application Circuit

10.7.4 AC Specifications - External Clocking Requirements

These specifications apply to crystal and clock oscillator external clocking.

Parameter	Symbol	Min.	Typ.	Max.	Units	Notes / Conditions
External clocking frequency accuracy	A_{OSC}	-50		50	ppm	Not tested in production
External clocking duty cycle	DC_{OSC}	40		60	%	
Holdover accuracy				50	ppm	

11.0 Timing Characteristics

Figure 35 depicts the timing reference points that apply to the timing diagrams shown in this section. For all timing characteristics, typical values are for $T_A = 25\text{ }^\circ\text{C}$ and nominal supply voltage. Minimum and maximum values are over the industrial $-40\text{ }^\circ\text{C}$ to $85\text{ }^\circ\text{C}$ temperature range and supply voltage ranges as shown in [“Operating Ranges” on page 42](#), except as noted.

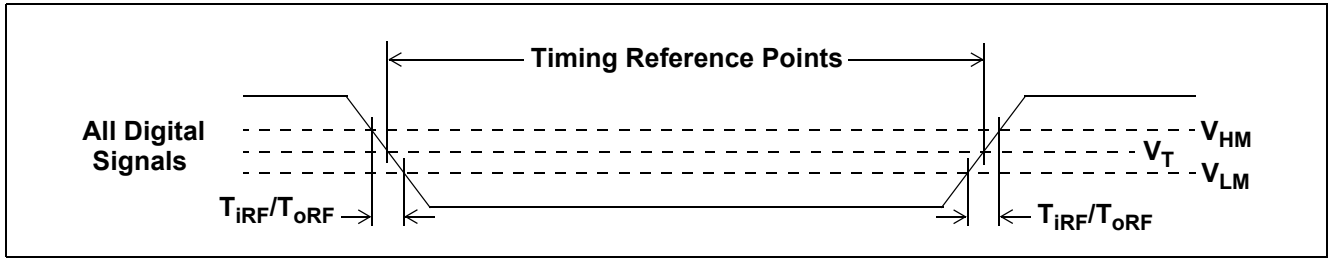

Figure 35 - Timing Parameter Measurement Digital Voltage Levels

11.1 TDM Interface Timing Parameters

All TDM timing parameters are with Full Duplex Communication Firmware running.

11.1.1 GCI and PCM Timing Parameters

Specifications for GCI and PCM timing modes are presented in the following table. The specifications apply to both port A and port B in slave operation.

A timing diagram that applies to GCI timing of the TDM interface is illustrated in [Figure 36](#).

Timing diagrams that apply to PCM timing of the TDM interface are illustrated in [Figure 37](#) and [Figure 38](#).

Parameter	Symbol	Min	Typ	Max	Unit	Notes / Conditions
PCLK period	t_{PCY}	122		7812.5	ns	1, 2
PCLK High pulse width	t_{PCH}	48				2
PCLK Low pulse width	t_{PCL}	48				2
Fall time of clock	t_{PCF}			8		
Rise time of clock	t_{PCR}			8		
FS delay (output rising or falling)	t_{FSD}	2		15		2
		2		25		3
FS setup time (input)	t_{FSS}	5				4
FS hold time (input)	t_{FSH}	0.5		125000 - $2t_{PCY}$		4
Data output delay	t_{DOD}	2		15		2
		2		25		3
Data output delay to High-Z	t_{DOZ}	0		10		5
Data input setup time	t_{DIS}	5				4
Data input hold time	t_{DIH}	0				4
Allowed PCLK jitter time	t_{PCT}			20		Peak-to-peak
Allowed Frame Sync jitter time	t_{FST}			20		Peak-to-peak

Note 1: PCLK frequency must be within 100 ppm.

Note 2: $C_{LOAD} = 40$ pF

Note 3: $C_{LOAD} = 150$ pF

Note 4: Setup times based on 2 ns PCLK rise and fall times; hold times based on 0 ns PCLK rise and fall times.

Note 5: Guaranteed by design, not tested in production.

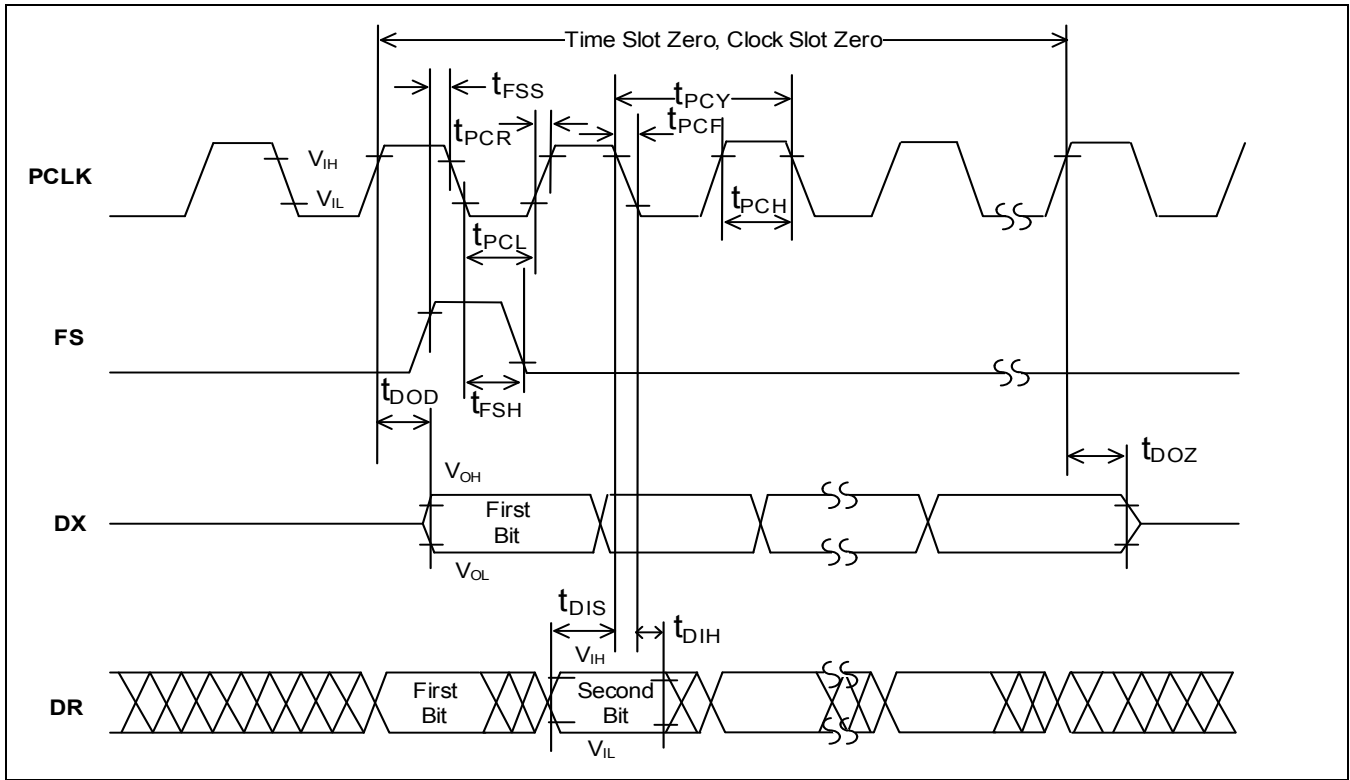

Figure 36 - GCI Timing, 8-bit

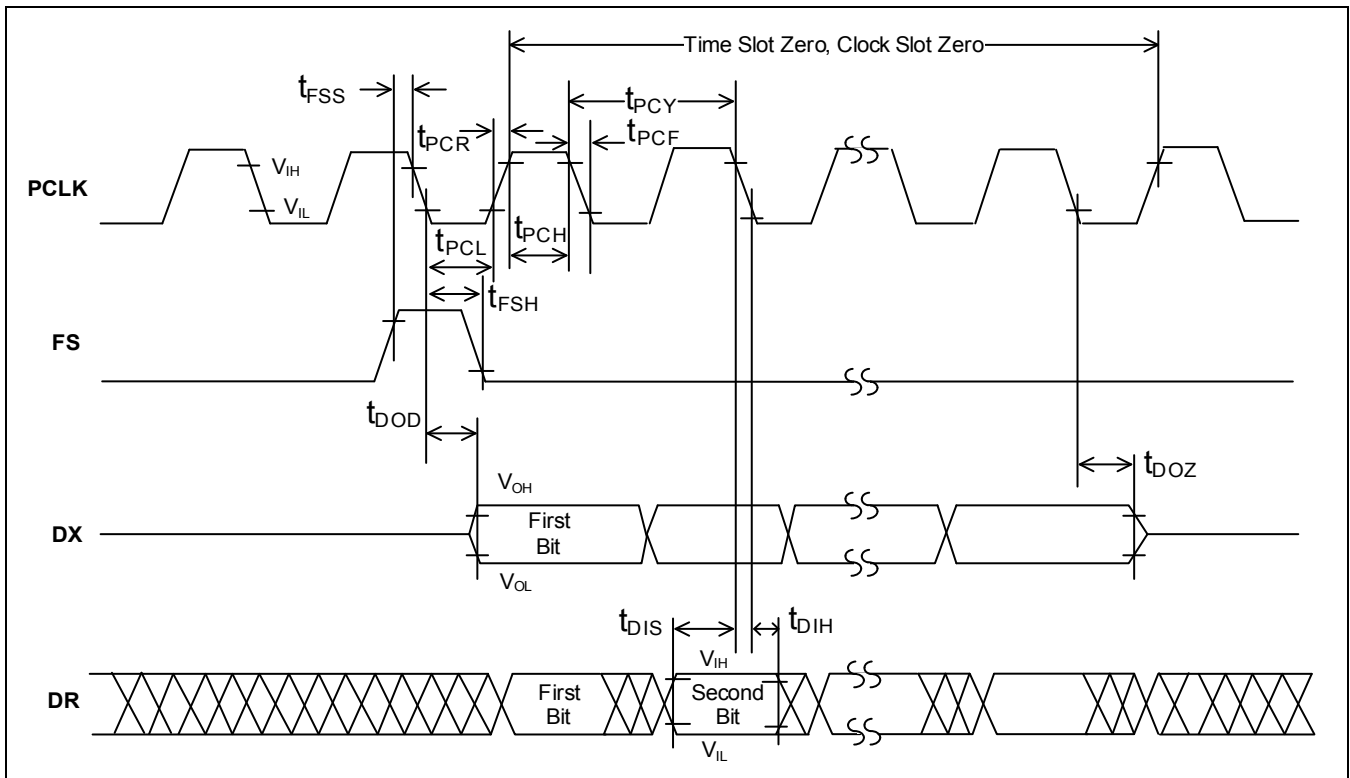

Figure 37 - PCM Timing, 8-bit with xeDX = 0 (Transmit on Negative PCLK Edge)

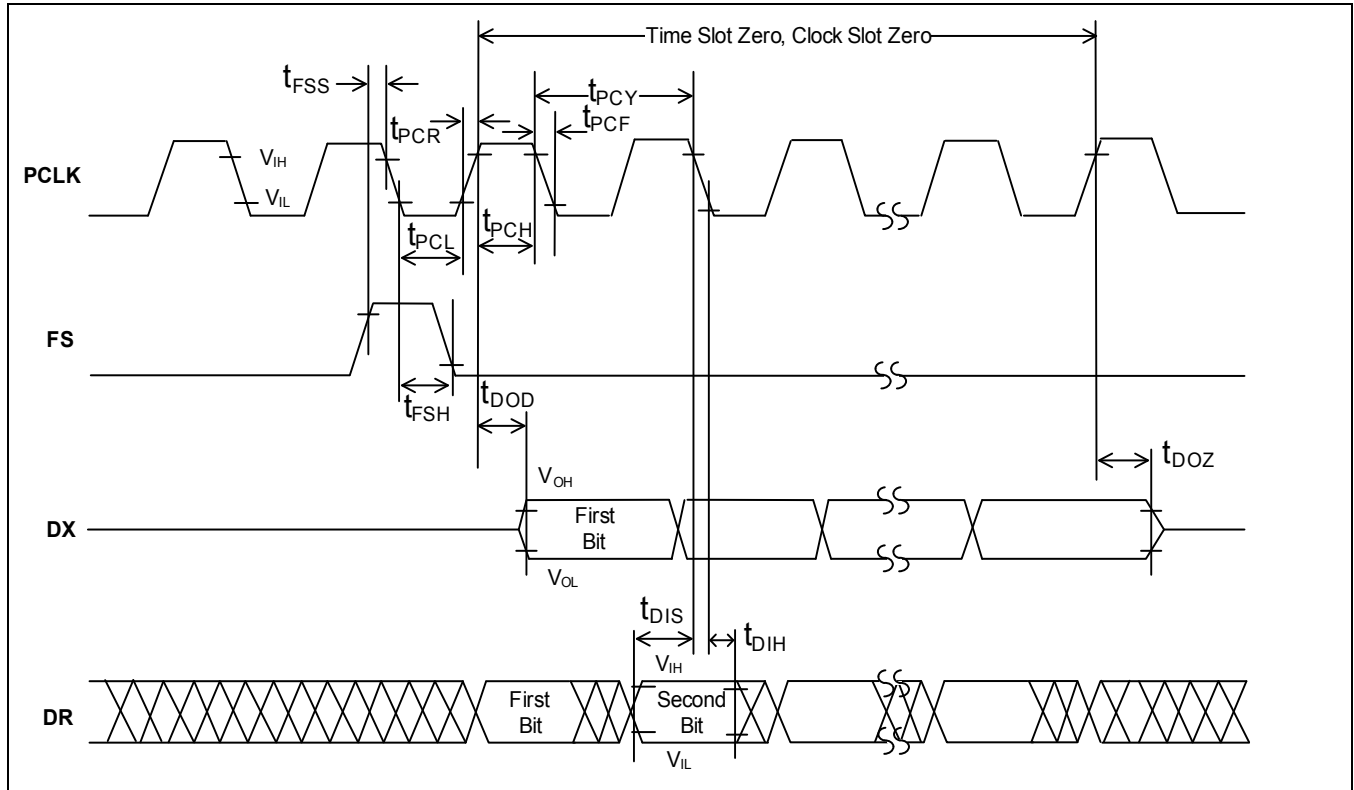

Figure 38 - PCM Timing, 8-bit with $x_{eDX} = 1$ (Transmit on Positive PCLK Edge)

11.1.2 I²S Timing Parameters

11.1.2.1 I²S Slave

Specifications for I²S Slave timing are presented in the following table. The specifications apply to both port A and port B. A timing diagram for the I²S Slave timing parameters is illustrated in [Figure 39](#).

Parameter	Symbol	Min.	Typ.	Max.	Units	Notes / Conditions
I2S_SCK Clock Period $f_s = 48 \text{ kHz}$ $f_s = 8 \text{ kHz}$	t_{ISSCP}		651.04 3.91		ns μs	
I2S_SCK Pulse Width High $f_s = 48 \text{ kHz}$ $f_s = 8 \text{ kHz}$	t_{ISSCH}	292.97 1.76		358.07 2.15	ns μs	
I2S_SCK Pulse Width Low $f_s = 48 \text{ kHz}$ $f_s = 8 \text{ kHz}$	t_{ISSCL}	292.97 1.76		358.07 2.15	ns μs	
I2S_SDI Setup Time	t_{ISDS}	5			ns	
I2S_WS Setup Time	t_{ISDS}	5			ns	
I2S_SDI Hold Time	t_{ISDH}	0			ns	
I2S_WS Hold Time	t_{ISDH}	0.5			ns	
I2S_SCK Falling Edge to I2S_SDO Valid	t_{ISOD}	2		15	ns	$C_{LOAD} = 40 \text{ pF}$

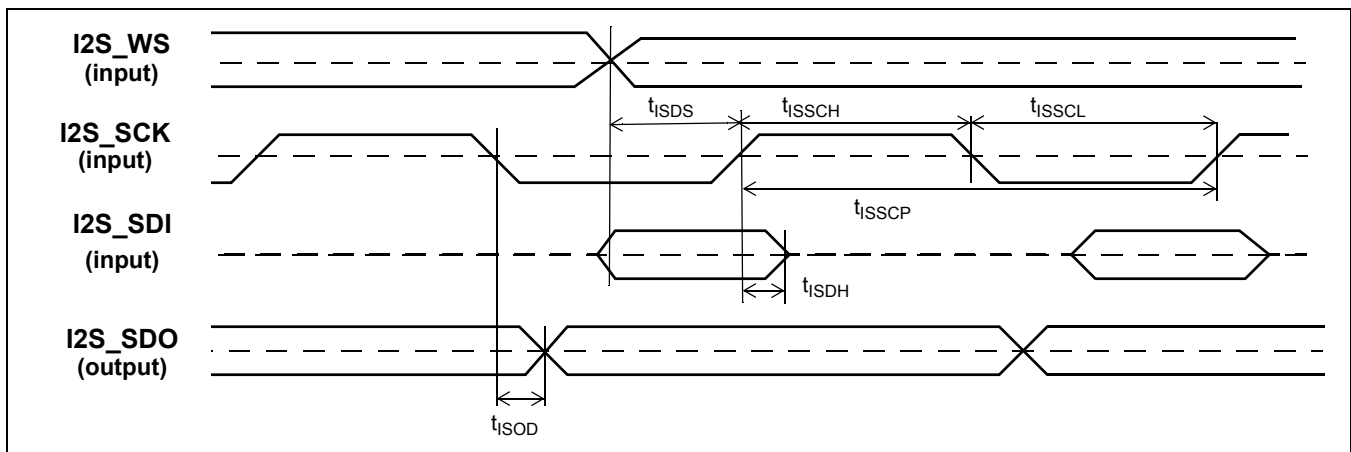

Figure 39 - Slave I²S Timing

11.1.2.2 I²S Master

Specifications for I²S Slave timing are presented in the following table. The specifications apply to both port A and port B. A timing diagram for the I²S Master timing parameters is illustrated in [Figure 40](#).

Parameter	Symbol	Min.	Typ.	Max.	Units	Notes/Conditions
I2S_SCK Clock Period $f_s = 48 \text{ kHz}$ $f_s = 8 \text{ kHz}$	t_{IMSCP}		651.04 3.91		ns μs	
I2S_SCK Pulse Width High $f_s = 48 \text{ kHz}$ $f_s = 8 \text{ kHz}$	t_{IMSCH}	318.0 1.95		333.0 1.96	ns μs	
I2S_SCK Pulse Width Low $f_s = 48 \text{ kHz}$ $f_s = 8 \text{ kHz}$	t_{IMSCL}	318.0 1.95		333.0 1.96	ns μs	
I2S_SDI Setup Time	t_{IMDS}	5			ns	
I2S_SDI Hold Time	t_{IMDH}	0			ns	
I2S_SCK Falling Edge to I2S_WS	t_{IMOD}	2		15	ns	$C_{LOAD} = 40 \text{ pF}$
I2S_SCK Falling Edge to I2S_SDO Valid	t_{IMOD}	2		15	ns	$C_{LOAD} = 40 \text{ pF}$

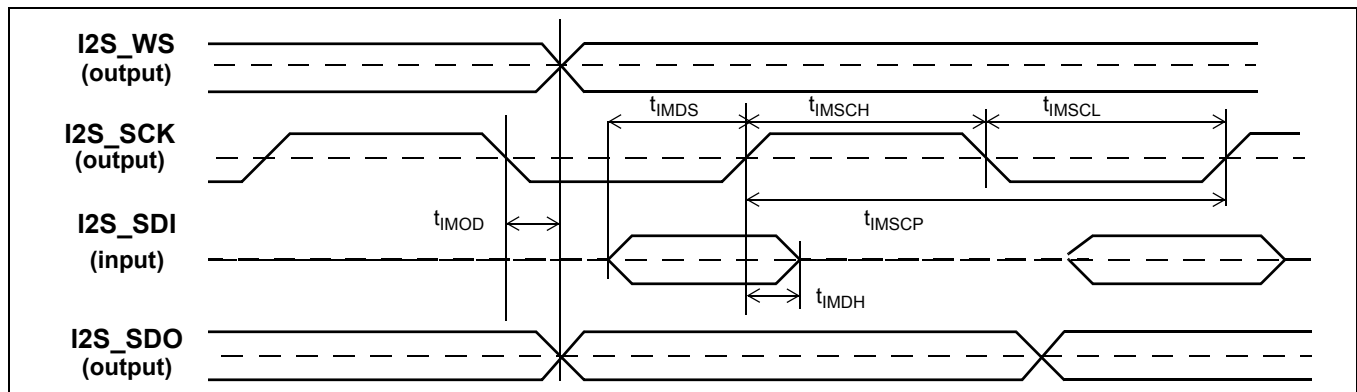

Figure 40 - Master I²S Timing

11.2 Host Bus Interface Timing Parameters

The HBI is the main communication port from the host processor to the ZL38067, this port can read and write all of the memory and registers on the ZL38067. The port can be configured as SPI Slave or I²C Slave.

For fastest command and control operation, use the SPI Slave configuration. The SPI Slave can be operated with HCLK speeds up to 25 MHz; the I²C Slave will operate with HCLK speeds up to 400 kHz.

11.2.1 SPI Slave Port Timing Parameters

The following table describes timing specific to the ZL38067 device. A timing diagram for the SPI Slave timing parameters is illustrated in [Figure 41](#).

For seamless control operation, both the SPI Slave timing and the system timing need to be considered when operating the SPI Slave at high speeds. System timing includes host set-up and delay times and board delay times.

Parameter	Symbol	Min.	Typ.	Max.	Units	Notes / Conditions
HCLK Clock Period	t_{SSCP}	40			ns	
HCLK Pulse Width High	t_{SSCH}	16	$t_{SSCP}/2$			1
HCLK Pulse Width Low	t_{SSCL}	16	$t_{SSCP}/2$			1
HDIN Setup Time	t_{SSDS}	5				
HDIN Hold Time	t_{SSDH}	0				
\overline{HCS} Asserted to HCLK Rising Edge: Write Read if host samples on falling edge Read if host samples on rising edge	t_{SHCSC}	5 5 $t_{SSFD} + \text{host HDOUT setup time to HCLK}$	$t_{SSCP}/2$ $t_{SSCP}/2$ $t_{SSFD} + t_{SSCP}/2$			
HCLK Driving Edge to HDOUT Valid	t_{SSOD}	2		15		$C_{LOAD} = 40 \text{ pF}$
\overline{HCS} Falling Edge to HDOUT Valid	t_{SSFD}	0		15		2, $C_{LOAD} = 40 \text{ pF}$
\overline{HCS} De-asserted to HDOUT Tristate	t_{SSOZ}	0		10		5, $C_{LOAD} = 40 \text{ pF}$
\overline{HCS} Pulse High	t_{SHCSH}	20	$t_{SSCP}/2$			1, 3
\overline{HCS} Pulse low	t_{SHCSL}				4	

Note 1: HCLK may be stopped in the high or low state indefinitely without loss of information. When \overline{HCS} is at low state, every 16 HCLK cycles, the 16-bit received data will be interpreted by the SPI interface logic.

Note 2: The first data bit is enabled on the falling edge of \overline{HCS} or on the falling edge of HCLK, whichever occurs last.

Note 3: The SPI Slave requires 61ns \overline{HCS} off time just to make the transition of \overline{HCS} synchronized with HCLK clock. In the command framing mode, there is no \overline{HCS} off time between each 16-bit command/data, and \overline{HCS} is held low until the end of command.

Note 4: If \overline{HCS} is not held low for 8 or 16 HCLK cycles exactly, the SPI Slave will reset. During byte or word framing mode, \overline{HCS} is held low for the whole duration of the command. Multiple commands can be transferred with \overline{HCS} low for the whole duration of the multiple commands. The rising edge of the \overline{HCS} indicates the end of the command sequence and resets the SPI Slave.

Note 5: Guaranteed by design, not tested in production.

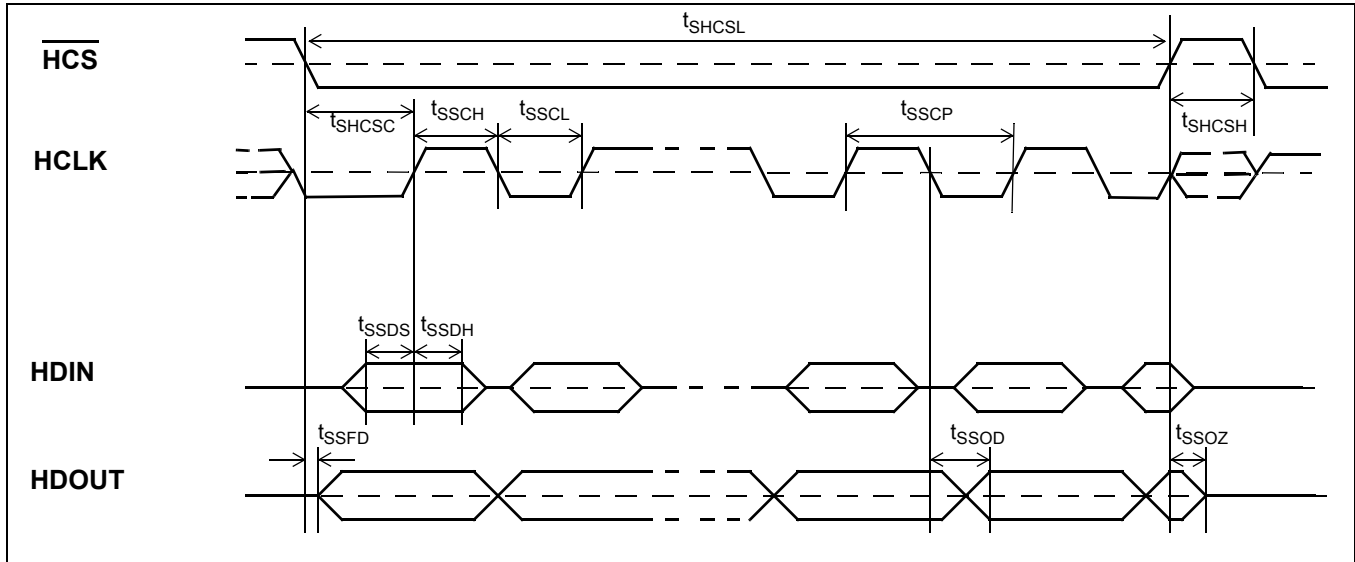

Figure 41 - SPI Slave Timing

11.2.2 I²C Slave Interface Timing Parameters

The I²C interface uses the SPI Slave interface pins.

Specifications for I²C interface timing are presented in the following table. A timing diagram for the I²C timing parameters is illustrated in [Figure 42](#).

Parameter	Symbol	Min.	Typ.	Max.	Units	Notes / Conditions
SCLK Clock Frequency	f_{SCL}	0		400	kHz	
START Condition Hold Time	t_{STARTH}	0.6			μ s	
SDA data setup time	t_{SDAS}	100			ns	
SDA Hold Time Input	t_{SDAH}	100			ns	
SDA Hold Time Output	t_{SDAH}	300			ns	
High period of SCLK	t_{SCLH}	0.6			μ s	
Low period of SCLK	t_{SCLL}	1.3			μ s	
STOP Condition Setup Time	t_{STOPS}	0.6			μ s	
Repeated Start Condition Setup Time	t_{STARTS}	0.6			μ s	
Pulse Width Spike Suppression, glitches ignored by input filter	t_{SP}	50			ns	

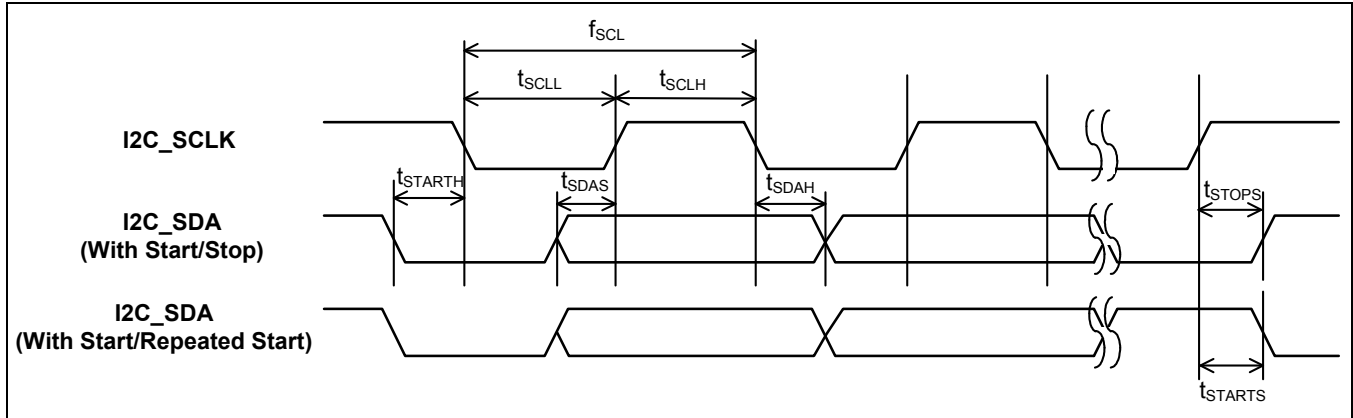

Figure 42 - I²C Timing Parameter Definitions

11.3 UART Timing Parameters

Specifications for UART timing are presented in the following table. Timing diagrams for the UART timing parameters are illustrated in [Figure 43](#) and [Figure 44](#).

Parameter	Symbol	Min.	Typ.	Max.	Units	Notes / Conditions
UART_RX and UART_TX bit width Baud rate = 115.2 kbps	t_{UP}		8.68		μ s	
Allowed baud rate deviation 8 bits with no parity				4.86	%	Guaranteed by design, not tested in production.

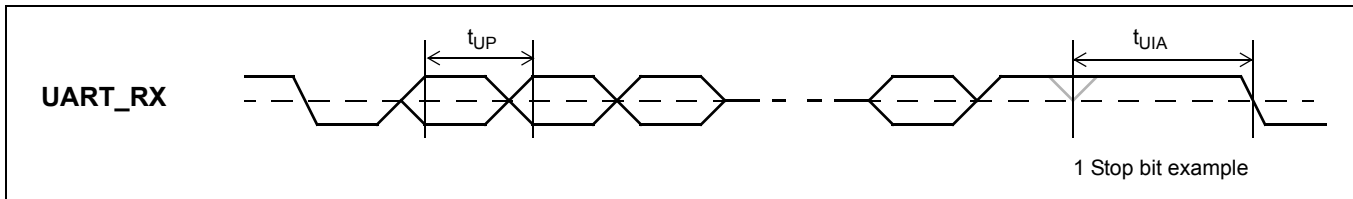

Figure 43 - UART_RX Timing

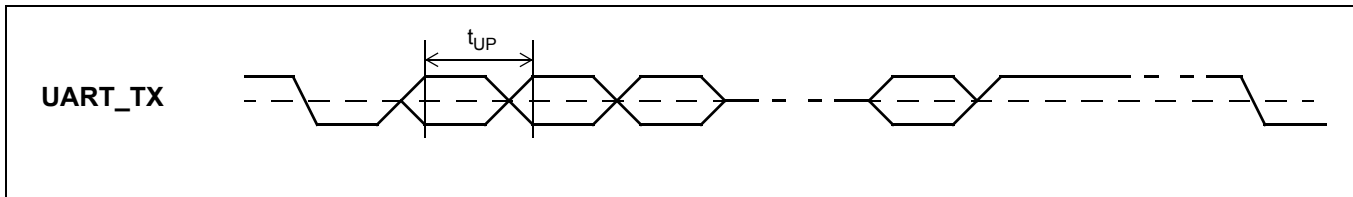

Figure 44 - UART_TX Timing

11.4 Master SPI Timing Parameters

Specifications for Master SPI timing are presented in the following table. A timing diagram for the Master SPI timing parameters is illustrated in [Figure 45](#).

Parameter	Symbol	Min.	Typ.	Max.	Units	Notes/Conditions
SM_CLK Clock Period	t_{MSCP}	40		320	ns	Max. 25.0 MHz
SM_CLK Pulse Width High	t_{MSCH}	$(t_{MSCP}/2) - 2$		160		
SM_CLK Pulse Width Low	t_{MSCL}	$(t_{MSCP}/2) - 2$		160		
SM_MISO Setup Time	t_{MSDS}	3				
SM_MISO Hold Time	t_{MSDHD}	0				
SM_CS Asserted to SM_CLK Sampling Edge	t_{MSCC}	$(t_{MSCP}/2) - 4$				
SM_CLK Driving Edge to SM_MOSI Valid	t_{MSOD}	-1		2		$C_{LOAD} = 40 \text{ pF}$
SM_MOSI Setup to SM_CLK Sampling Edge	t_{MSOS}	$(t_{MSCP}/2) - 4$				$C_{LOAD} = 40 \text{ pF}$
SM_MOSI Hold Time to SM_CLK Sampling Edge	t_{MSOHD}	$(t_{MSCP}/2) - 4$				$C_{LOAD} = 40 \text{ pF}$
SM_CS Hold Time after last SM_CLK Sampling Edge	t_{MSCSHD}	$(t_{MSCP}/2) - 4$				
SM_CS Pulse High	t_{MSCSH}	$(t_{MSCP}/2) - 2$				

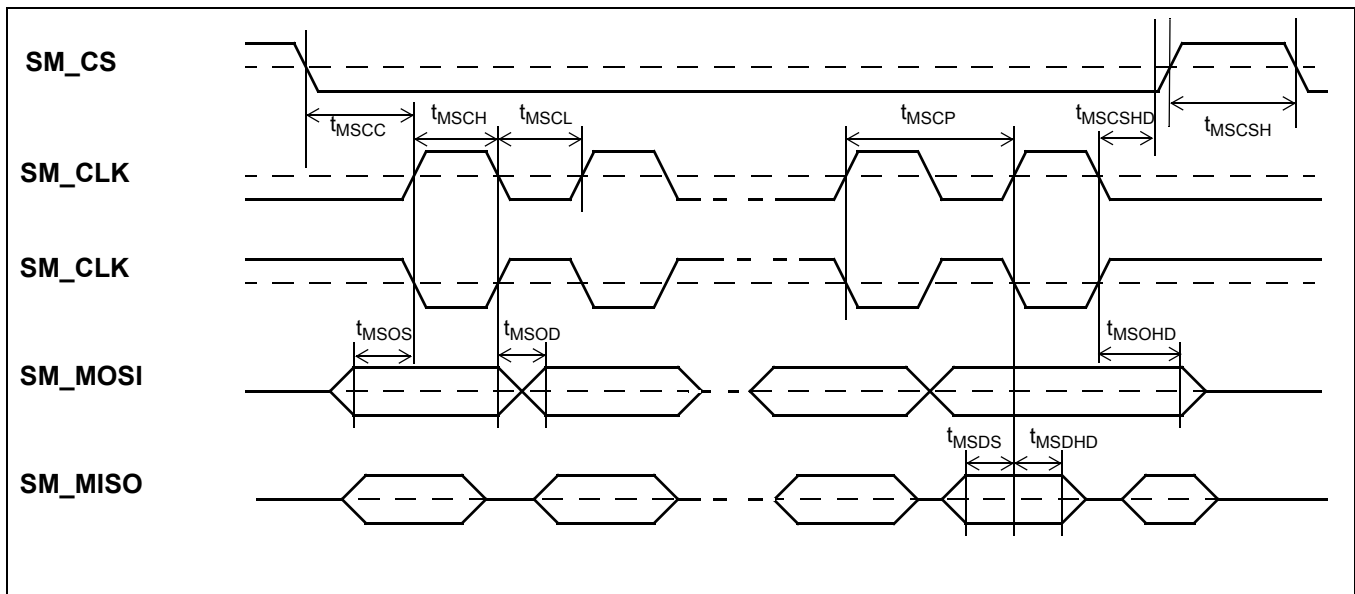

Figure 45 - Master SPI Timing

12.0 AEC Tuning

To optimize the acoustic properties of a given system design, the Audio Processor firmware requires gain and level tuning. The mechanical design, including the speaker and microphone quality and placement, will all affect the system's acoustic performance. Microsemi has developed *MiTuner*™ GUI Software (ZLS38508) and the Microsemi Audio Interface Box (AIB) Evaluation Kit (ZLE38470BADA) to automatically optimize the firmware's tunable parameters for a given hardware design, facilitating the system design process and eliminating the need for tedious manual tuning. In order to achieve a high level of acoustic performance for a given enclosure, the *MiTuner* GUI Software performs both Auto Tuning and Subjective Tuning.

Access to the UART and TDM port of the ZL38067 need to be provided on the system board in order to perform Auto Tuning or Subjective Tuning with the ZLS38508 software. [Figure 46](#) shows the nodes that need to be made available and illustrates an AIB Header that when mounted, will provide a direct connection to the Audio Interface Box cable (no soldering or jumpers required). TDM port A is shown, but port B can be used instead. The header only needs to be populated on the system board(s) that are used for tuning evaluation.

Note: Any connections to a host processor need to be isolated from the UART and I²S ports during the tuning process. If a host processor is connected to these ports, a resistor should be placed between the host and each ZL38067 port signal, so that the resistor can be removed to isolate the host from the ZL38067 without interfering with the ZL38067's connection to the AIB.

To interface between the header and the AIB, a 10-wire ribbon cable is used. The cable is terminated on both ends with a double row, 5 position, 100 mil (2.54 mm) female socket strip. Pin 10 on each socket is keyed to ensure proper signal connection. On the system board header pin 10 must be removed, or alternatively both pins 9 and 10 can be eliminated to reduce the space needed on the system board. Signal integrity series termination resistors are provided for the interface in the AIB.

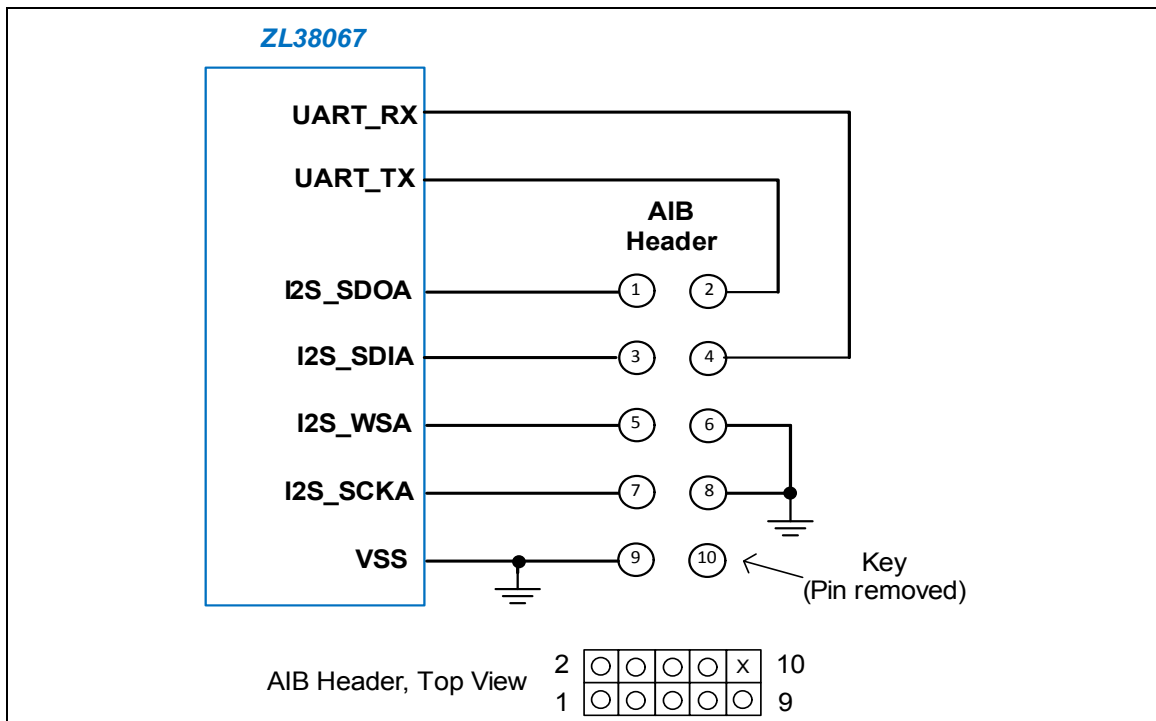

Figure 46 - AIB System Board Connection

Note: A Samtec TSW-105-07-L-D through-hole terminal strip, or a Samtec TSM-105-01-L-DV surface mount terminal strip, or a suitable equivalent can be used for the AIB Header. The header is a double row, 5 position, 10-pin male 100 mil (2.54 mm) unshrouded terminal strip with 25 mil (0.64 mm) square vertical posts that are 230 mils (5.84 mm) in length.

13.0 Package Outline Drawings

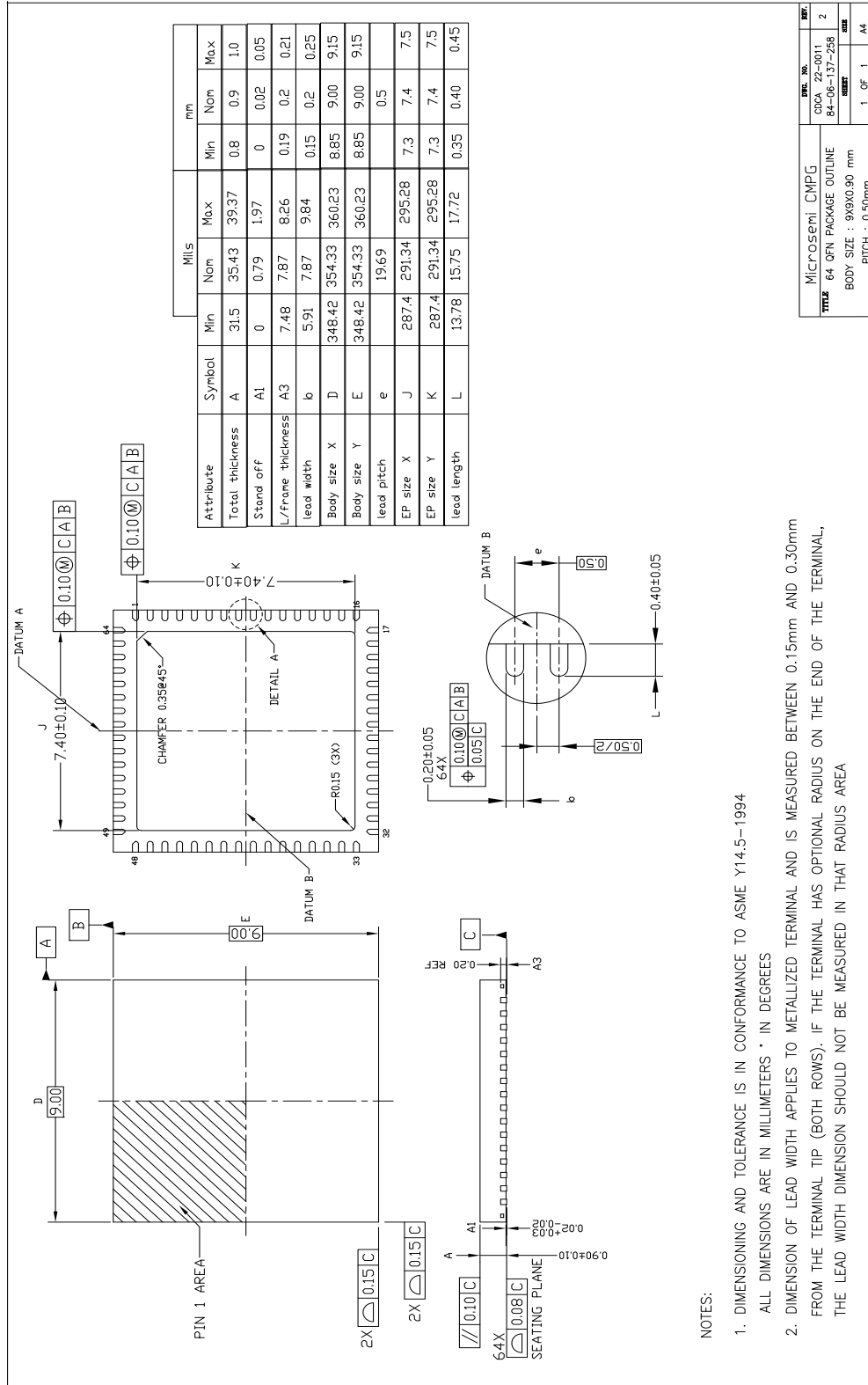
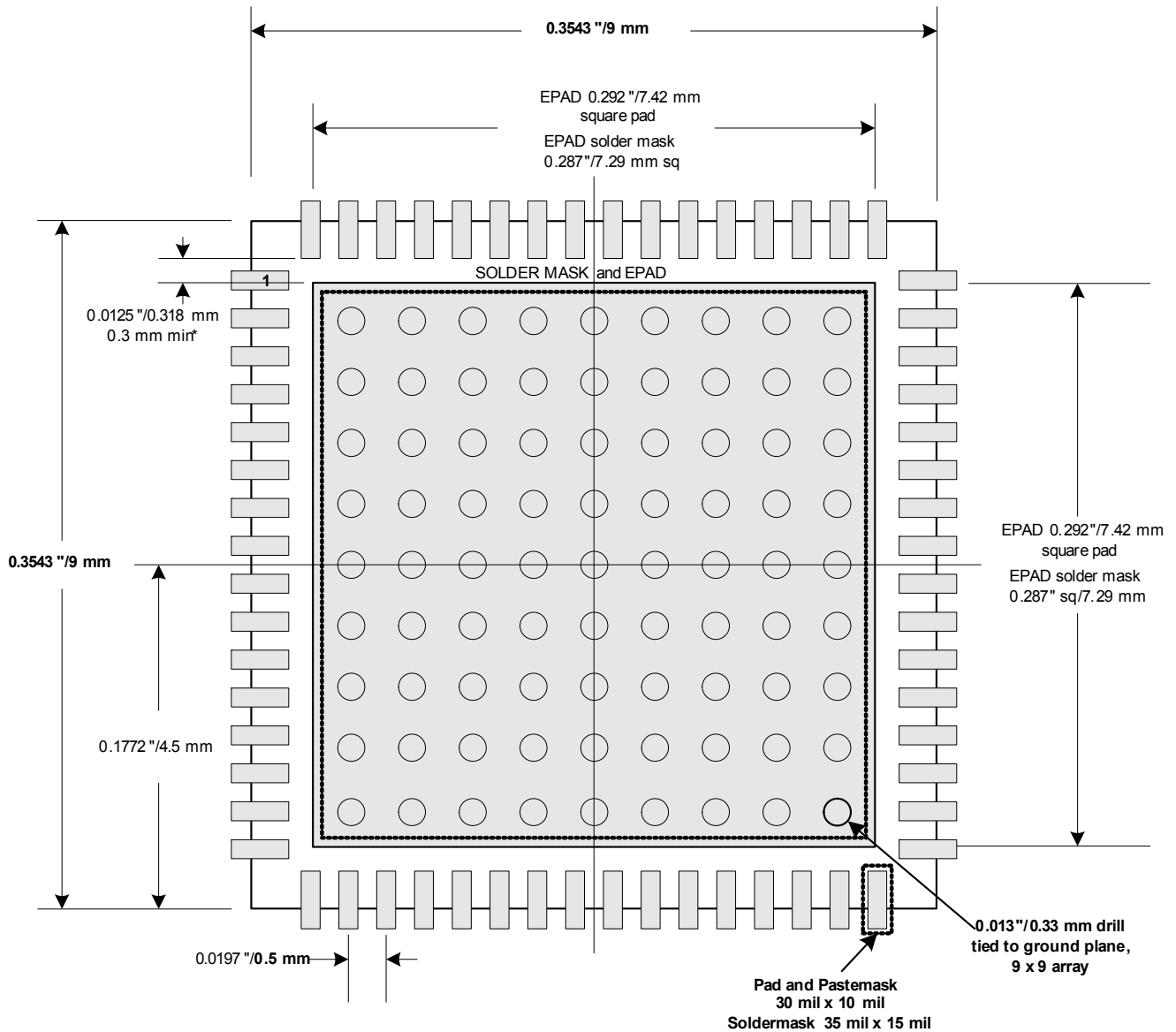

Figure 47 - 64-Pin QFN



64-QFN
9 mm x 9 mm, 0.5 mm pitch

* Minimum spacing between pins and epad must be 0.3 mm
 Recommended EPAD configuration uses 0.292"/7.42 mm square pad tied to a ground plane with a 9 x 9 array of 0.013"/0.33 mm vias. This is necessary for good thermal performance.

Figure 48 - Recommended 64-Pin QFN Land Pattern – Top View

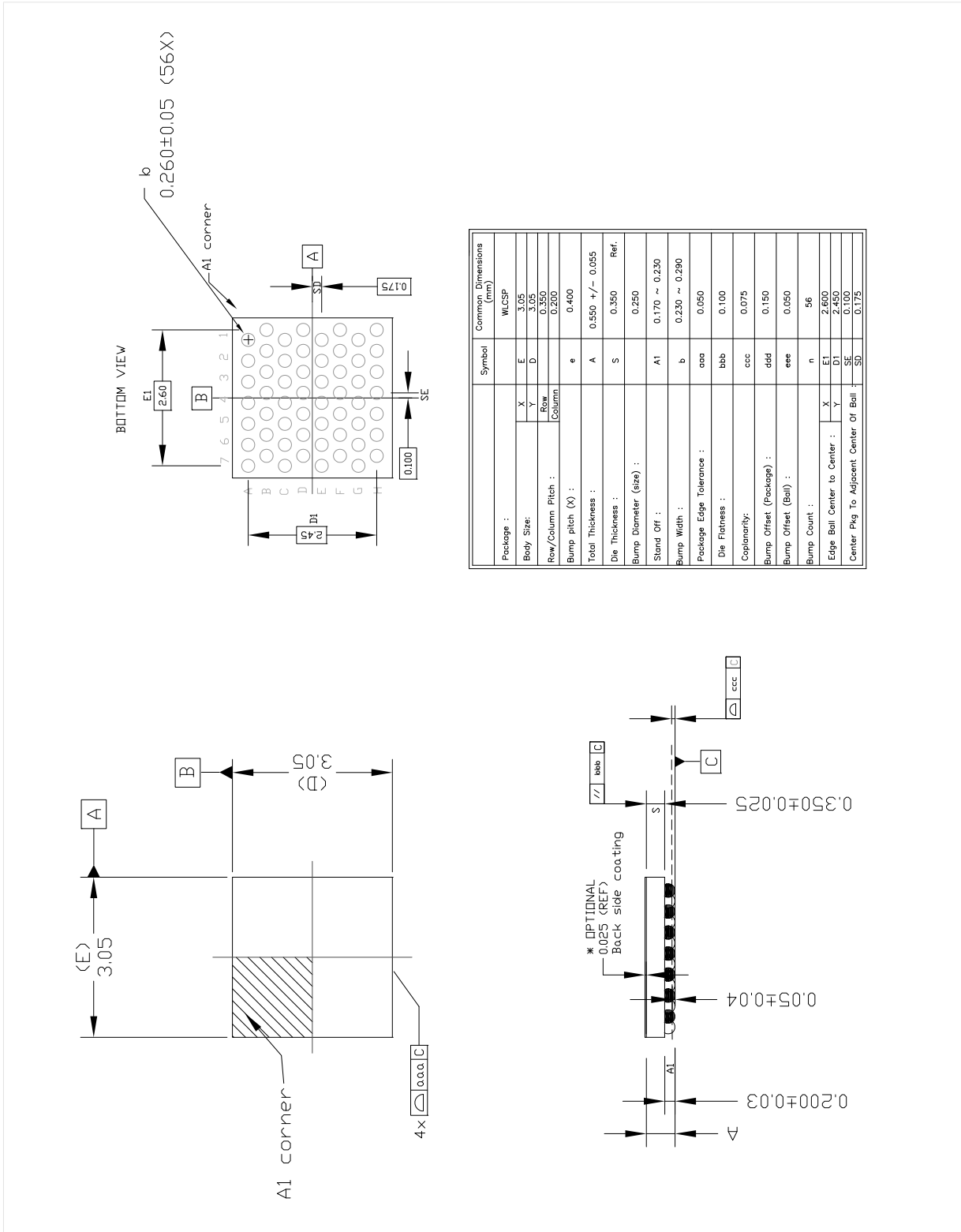

Figure 49 - 56-Ball WLCSP

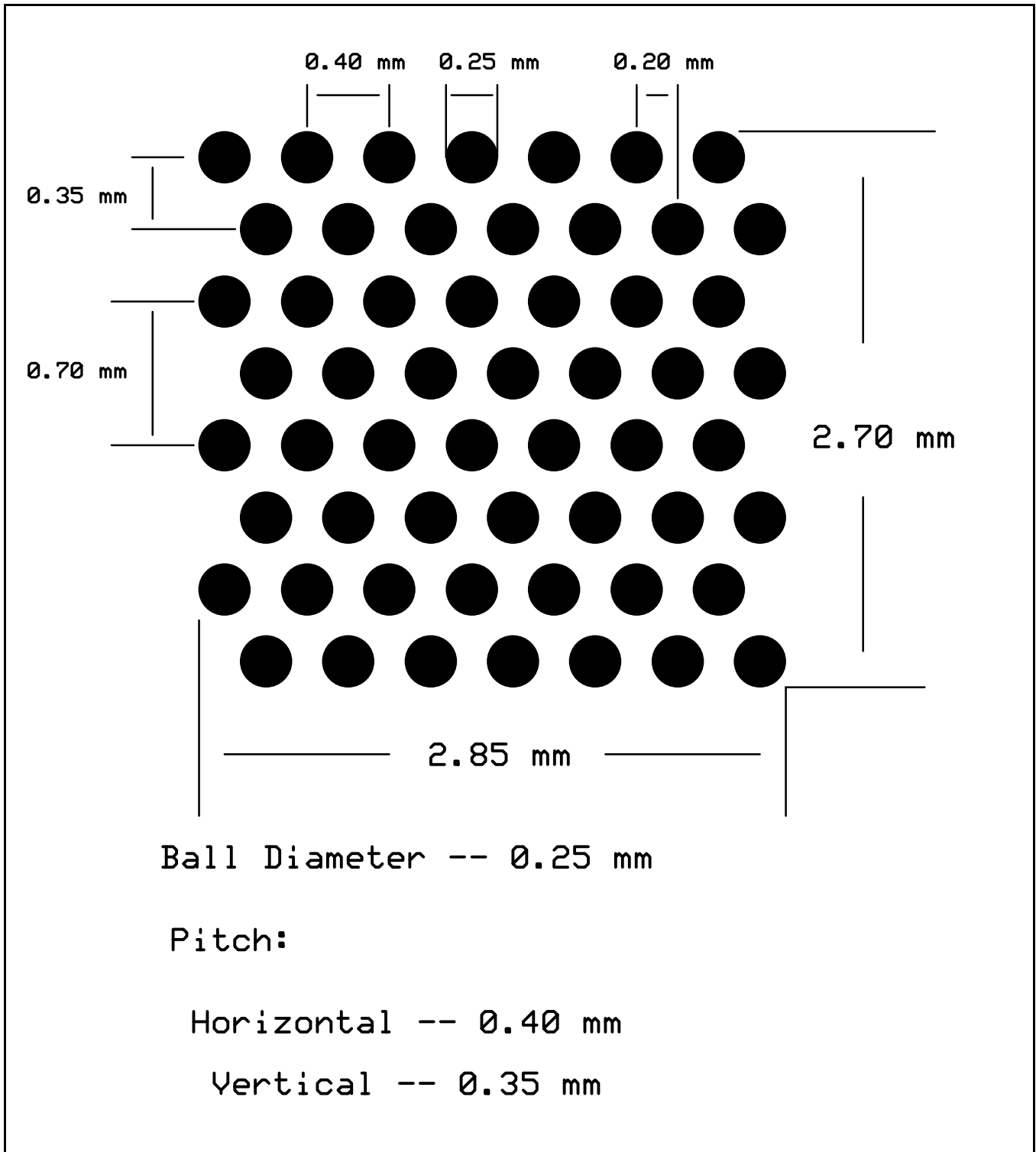

Figure 50 - 56-Ball WLCSP Staggered Balls Expanded Bottom View

14.0 Revision History

The following table lists substantive changes that were made to this Preliminary Data Sheet revision.

Changes	Pages
Added "Command Framing triggers to ASR-assist feature"	1
Added crystal-less operation and bootstrap configuration.	31, 50
Added typical power consumption values to section 10.4.7	45

Table 18 - List of Changes to the Preliminary Data Sheet

THIS PAGE IS INTENTIONALLY BLANK

Information relating to products and services furnished herein by Microsemi Corporation or its subsidiaries (collectively "Microsemi") is believed to be reliable. However, Microsemi assumes no liability for errors that may appear in this publication, or for liability otherwise arising from the application or use of any such information, product or service or for any infringement of patents or other intellectual property rights owned by third parties which may result from such application or use. Neither the supply of such information or purchase of product or service conveys any license, either express or implied, under patents or other intellectual property rights owned by Microsemi or licensed from third parties by Microsemi, whatsoever. Purchasers of products are also hereby notified that the use of product in certain ways or in combination with Microsemi, or non-Microsemi furnished goods or services may infringe patents or other intellectual property rights owned by Microsemi.

This publication is issued to provide information only and (unless agreed by Microsemi in writing) may not be used, applied or reproduced for any purpose nor form part of any order or contract nor to be regarded as a representation relating to the products or services concerned. The products, their specifications, services and other information appearing in this publication are subject to change by Microsemi without notice. No warranty or guarantee express or implied is made regarding the capability, performance or suitability of any product or service. Information concerning possible methods of use is provided as a guide only and does not constitute any guarantee that such methods of use will be satisfactory in a specific piece of equipment. It is the user's responsibility to fully determine the performance and suitability of any equipment using such information and to ensure that any publication or data used is up to date and has not been superseded. Manufacturing does not necessarily include testing of all functions or parameters. These products are not suitable for use in any medical and other products whose failure to perform may result in significant injury or death to the user. All products and materials are sold and services provided subject to Microsemi's conditions of sale which are available on request.

**For more information about all Microsemi products
visit our website at
www.microsemi.com**

TECHNICAL DOCUMENTATION – NOT FOR RESALE



Microsemi Corporate Headquarters
One Enterprise, Aliso Viejo CA 92656 USA
Within the USA: +1 (949) 380-6100
Sales: +1 (949) 380-6136
Fax: +1 (949) 215-4996

Microsemi Corporation (NASDAQ: MSCC) offers a comprehensive portfolio of semiconductor solutions for: aerospace, defense and security; enterprise and communications; and industrial and alternative energy markets. Products include mixed-signal ICs, SoCs, and ASICs; programmable logic solutions; power management products; timing and voice processing devices; RF solutions; discrete components; and systems. Microsemi is headquartered in Aliso Viejo, Calif. Learn more at www.microsemi.com.

© 2015 Microsemi Corporation. All rights reserved. Microsemi and the Microsemi logo are trademarks of Microsemi Corporation. All other trademarks and service marks are the property of their respective owners.



Компания «ЭлектроПласт» предлагает заключение долгосрочных отношений при поставках импортных электронных компонентов на взаимовыгодных условиях!

Наши преимущества:

- Оперативные поставки широкого спектра электронных компонентов отечественного и импортного производства напрямую от производителей и с крупнейших мировых складов;
- Поставка более 17-ти миллионов наименований электронных компонентов;
- Поставка сложных, дефицитных, либо снятых с производства позиций;
- Оперативные сроки поставки под заказ (от 5 рабочих дней);
- Экспресс доставка в любую точку России;
- Техническая поддержка проекта, помощь в подборе аналогов, поставка прототипов;
- Система менеджмента качества сертифицирована по Международному стандарту ISO 9001;
- Лицензия ФСБ на осуществление работ с использованием сведений, составляющих государственную тайну;
- Поставка специализированных компонентов (Xilinx, Altera, Analog Devices, Intersil, Interpoint, Microsemi, Aeroflex, Peregrine, Syfer, Eurofarad, Texas Instrument, Miteq, Cobham, E2V, MA-COM, Hittite, Mini-Circuits, General Dynamics и др.);

Помимо этого, одним из направлений компании «ЭлектроПласт» является направление «Источники питания». Мы предлагаем Вам помощь Конструкторского отдела:

- Подбор оптимального решения, техническое обоснование при выборе компонента;
- Подбор аналогов;
- Консультации по применению компонента;
- Поставка образцов и прототипов;
- Техническая поддержка проекта;
- Защита от снятия компонента с производства.



Как с нами связаться

Телефон: 8 (812) 309 58 32 (многоканальный)

Факс: 8 (812) 320-02-42

Электронная почта: org@eplast1.ru

Адрес: 198099, г. Санкт-Петербург, ул. Калинина, дом 2, корпус 4, литера А.