

SMARTSWITCH™

OLED Programmable
Rocker Switch



NIKK
SWITCHES

DISTINCTIVE CHARACTERISTICS

- White monochrome OLED featuring sharp contrast and high resolution with 96 x 64 pixels
- Wide viewing angle of 180° and large 0.92" display with exceptional contrast
- Organic LED technology in display rocker (patent pending)
- Multifunction programmable device: select with rocker, push for activation
- All-in-one solution: replaces multiple switches and displays with one device in a small package
- Easy navigation through structured menus, both forward and reverse and up and down
- Waterprotected and dust tight; conforms to IP64 of IEC60529 Standards on panel surface
- Displays up to 8 lines with 16 characters 5 x 7 each, or 5 lines with 12 characters 7 x 10 each
- Graphics and animations
- Long life OLED with 52,000 hours at 30% illumination
- Panel mount with easy snap-in installation
- Short 14.6mm (.575") behind-panel depth for compact spaces
- Commands and data supplied via serial communications protocol (SPI)
- Stylish black housing design with matte finish complements any application
- High reliability and long mechanical and electrical life of one million actuations minimum

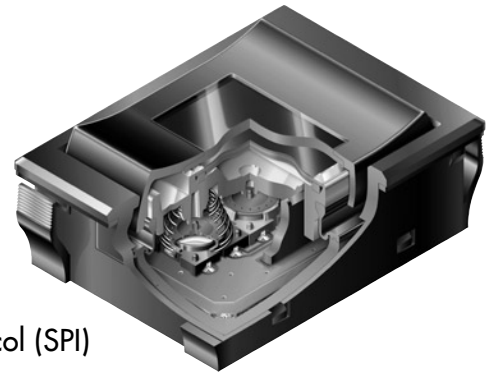

APPLICATIONS

Application Specific Keyboards	Medical
Aerospace and Military	Process Control
Broadcast Panels	Real Time Data Monitoring
Configuration Menus	Security Systems
Factory Automation	Simulation
Lighting/Stage/Theater Controls	Test Equipment
Machine Control/Robotics	







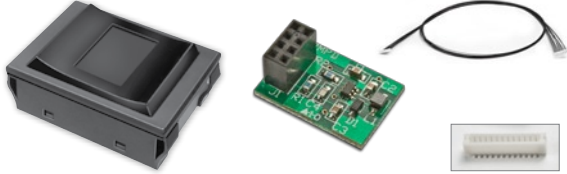

Actual Size

PRODUCT OVERVIEW

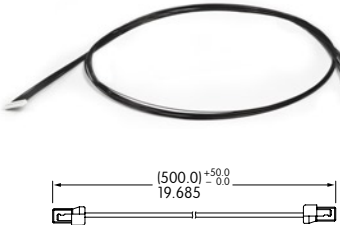
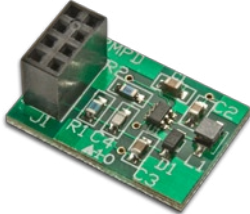
NKK provides several options for ease of prototyping. The OLED Rocker Kit **IS18WWC1W-K** includes all items that are needed for a quick start of any project. The **IS-DEV Kit-8** is a complete kit for demonstration with pre-programmed option or to be operated with customized graphics.

All items below can also be purchased separately to accommodate customers' needs.

Part Number	Description
IS18WWC1W-K	<p>OLED Rocker Kit: SP3T Switch Rocker (ON) (ON) (ON) Pushbutton Normally OFF Packaged with Charge Pump IS-CHPMP, AT715 Connector Cable, AT097 PCB Connector</p> 
IS18WWC1W	<p>OLED Rocker Switch: SP3T Switch Rocker (ON) (ON) (ON) Pushbutton Normally OFF</p> 
AT715	<p>Connector Cable with (2) JST 12SUR-32S Connectors</p> 
IS-CHPMP	<p>Charge Pump Voltage Booster Input: 2.7~5.5V Output: 1.6V Meets all OLED power requirements</p> 
AT097	<p>PCB Connector Female SMT Connector JST BM12B-SURS</p> 
 <p>IS-DEV Kit-8</p>	<p>Plug and play Dev Kit Ready to use Pre-programmed for instant demo Easy creation, testing and display for rapid prototype designs</p> 

SWITCH SPECIFICATIONS

Circuit	Single Pole Three Throw (Momentary)					
Contact Position	Top		Center		Bottom	
	Normal	Down	Normal	Down	Normal	Down
	OFF	(ON) 9-12	OFF	(ON) 10-12	OFF	(ON) 11-12
Electrical Capacity (Resistive Load)	3VA maximum DC					
Contact Resistance	200 milliohms maximum					
Insulation Resistance	500 megohms minimum @ 250V DC					
Dielectric Strength	250V AC for 1 minute minimum					
Electrostatic Resisting Pressure	15kV minimum					
Mechanical Endurance	1,000,000 operations minimum					
Electrical Endurance	1,000,000 operations minimum					
Operating Force	6.0 Newtons at center of cap					
Total Travel	1.4mm (.055") at center of cap					

OLED SPECIFICATIONS

Characteristics of Display

Display Device	Single color OLED display
Display Mode	Passive matrix
Pixel Format	96 x 64 pixels (horizontal x vertical)
Pixel Size	0.16mm x 0.177mm (horizontal x vertical)
Interface	Serial (SPI) interface
Color	White/Black (normally White)
Splash & Dust Proof	Conforms to IP64 of IEC60529 standards on panel surface
Operating Temperature Range	-20°C ~ +70°C (-4°F ~ +158°F)
Storage Temperature Range	-25°C ~ +80°C (-13°F ~ +176°F)
Operating Life Time (Display)	52,000 hours (30% brightness); 15,600 hours (100% brightness)

Absolute Maximum Ratings (Temperature at 25°C)

Items	Symbols	Ratings
Supply Voltage for Logic/Interface	VDDA	-0.3V to +3.6V
Supply Voltage for Drive	VAH	-0.3V to +18.0V
Input Voltage	V _{in}	-0.3V to VDDA +0.3V

Recommended Operating Conditions

Items	Symbols	Minimum	Typical	Maximum
Supply Voltage for Logic/Interface	VDDA	2.7V	2.8V	2.9V
Supply Voltage for Drive	VAH	14.5V	15.0V	15.5V
Input High Level Voltage	V _{IH}	0.75 x VDDA	—	VDDA
Input Low Level Voltage	V _{IL}	0.0	—	0.25V x VDDA

Current Consumption

(Temperature at 25°C, VDDA = 2.8V, VAH = 15.0V)

Items	Symbols	Min	Typical	Max
All-Pixels-On Mode *Drive System Power Current	I _{H1}	—	11.0mA	13.2mA
All-Pixels-On Mode *Logic/IF System Power Current	I _{DD1}	—	0.58mA	0.72mA
Sleep Mode **Drive System Power Current	I _{H2}	—	—	10μA
Sleep Mode **Logic/IF System Power Current	I _{DD2}	—	—	10μA

* All pixels shall be turned on with the maximum level gray scale

** All pixels shall be turned off (while chip is operating)

Optical Characteristics

(Temperature at 25°C, Initial Value: depends on initial setting)

Items	Minimum	Typical	Maximum
Brightness	75 cd/m ²	100 cd/m ²	125 cd/m ²
Chromaticity	(x)	*1	*1
	(y)	*1	*1
Contrast	100	—	—

* Chromaticity range is the area of the ellipse. (See Chromaticity Diagram next page) The ellipse passes through points A, B, C and D and designates the center of each side of the quadrangle.

Chromaticity Diagram

Point	Chromaticity X	Chromaticity Y
A	0.3441	0.3663
B	0.2983	0.3384
C	0.2799	0.2881
D	0.3257	0.3160

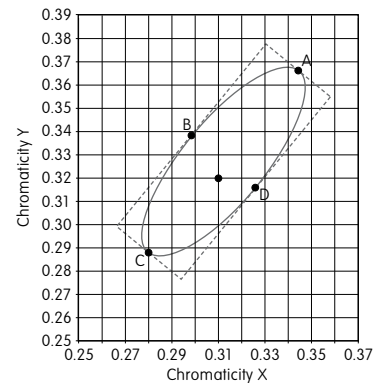

TIMING SPECIFICATIONS

AC Characteristics

(Temperature at -20°C ~ +70°C), VDDA = 2.8V, VAH = 16V

Items	Symbols	Minimum	Typical	Maximum
Clock Cycle Time	t _{cycle}	100ns	—	—
A0 Setup Time	t _{SWDS}	65ns	—	—
A0 Hold Time	t _{SWDN}	35ns	—	—
XCS Setup Time	t _{CWS}	65ns	—	—
XCS Hold Time	t _{CWH}	95ns	—	—
High Level XCS Pulse Width	t _{CSBH}	*10ns	—	—
Write Data Setup Time	t _{WDTS}	10ns	—	—
Write Data Hold Time	t _{WDTH}	20ns	—	—
SCL Low Time	t _{SCLL}	45ns	—	—
SCL High Time	t _{SCLH}	45ns	—	—
SCL Rise Time	t _r	—	—	1.5ns
SCL Fall Time	t _f	—	—	1.5ns

* Requires more than 100ns after resetting software

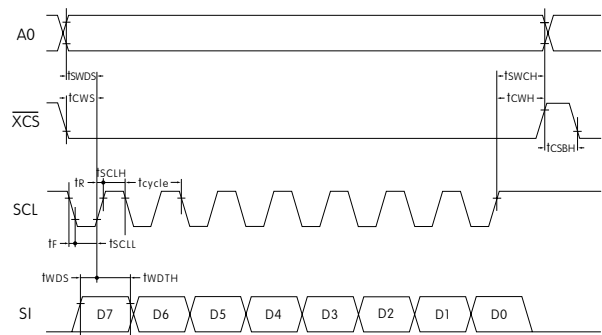

BLOCK DIAGRAM & PIN CONFIGURATIONS



IS18WWC1W

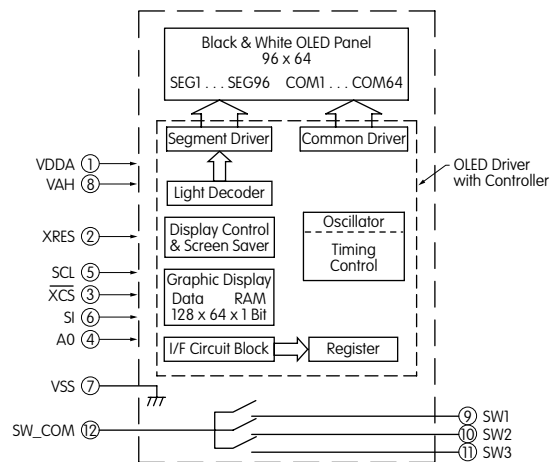

Pin No.	Symbol	Name	Function
①	VDDA	Logic Type Power Source	
②	XRES	Reset	Terminal to initialize IC built-in logic; initializes with low level
③	XCS	Chip Select	Slave select for SPI. This line is active low.
④	A0	Address	Terminal to input control signals of command/parameter Set low at time of command input and high level at the time of parameter input.
⑤	SCL	Serial Clock	Read command/parameter at time of SCL signal standing up
⑥	SI	Serial Data Input	Terminal to input command/parameter by SPI
⑦	VSS	Ground	
⑧	VAH	Drive Type Power Source	
⑨	SW1	Switch Terminal 1	N/O
⑩	SW2	Switch Terminal 2	N/O
⑪	SW3	Switch Terminal 3	N/O
⑫	SW_COM	Switch Common Terminal	

SMARTSWITCH TYPICAL DIMENSIONS

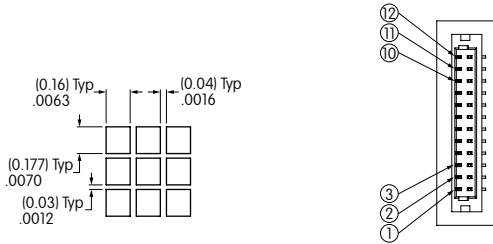
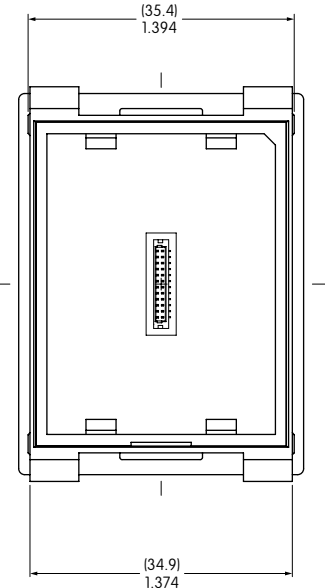
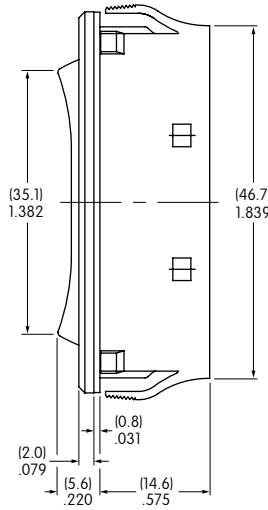
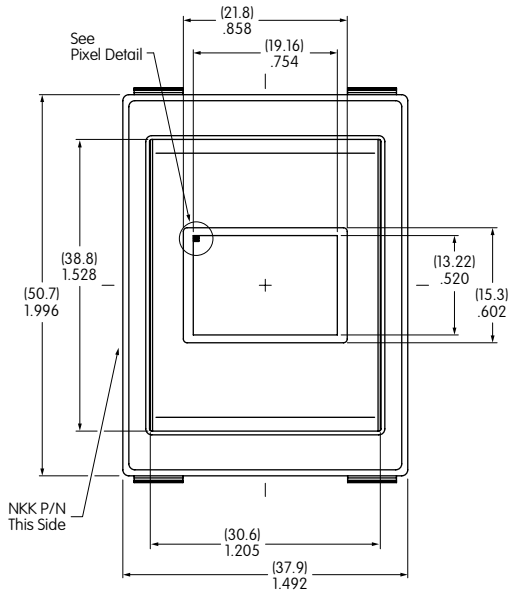

Pixel Detail

Terminal Connector Detail

Panel Thickness Range

.039 ~ .157"
(1.0mm ~ 4.0mm)

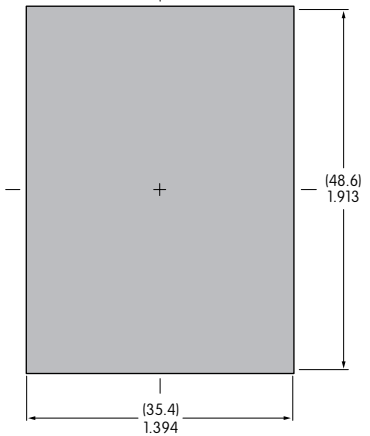

STATE TRANSITION

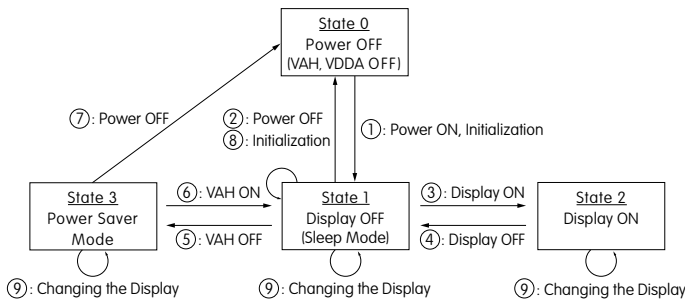

State Number	State	Display	Sleep	VAH	VDDA	Changing the Display
0	Power OFF	OFF	—	OFF	OFF	Disable
1	Display OFF	OFF	ON	ON	ON	Enable
2	Display ON	ON	OFF	ON	ON	Enable
3	Power Saver	OFF	ON	OFF	ON	Enable

Power ON/OFF Sequence

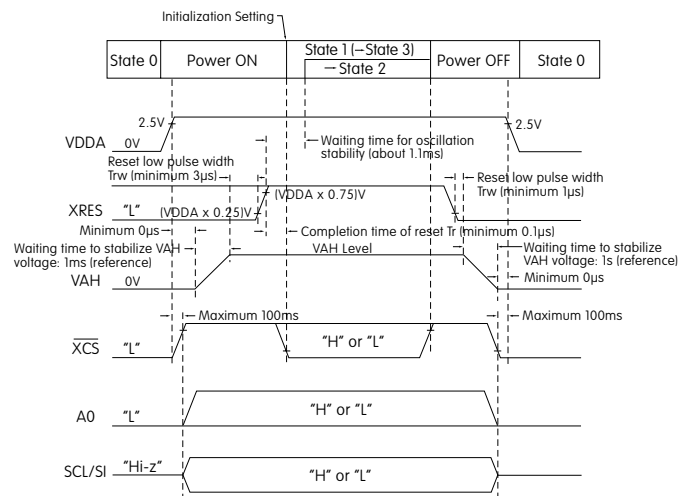

STATE TRANSITION (CONTINUED)

State Transition	Transition	Reference or Setting Procedure
①	Power ON	Refer to "Power ON/OFF Sequence" → Refer to "Initialization Setting"
②	Power OFF	Refer to "Power ON/OFF Sequence"
③	Display ON	Refer to "Display ON/OFF Sequence"
④	Display OFF	
⑤	VAH OFF	Wait until VAH becomes stable
⑥	VAH ON	
⑦	Power OFF	Refer to "Power ON/OFF Sequence"
⑧	Initialization	Refer to "Initialization Setting"
⑨	Display Change	Image Rewriting
		Display Settings

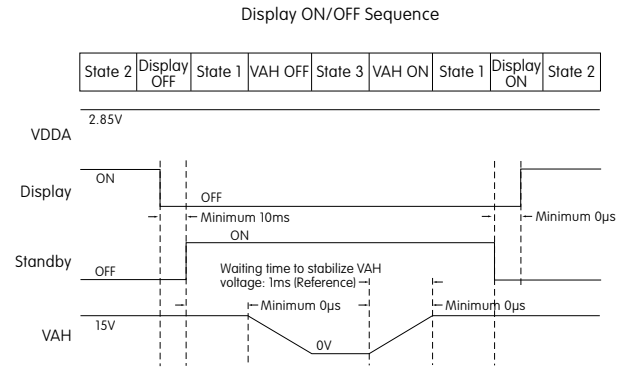

INITIALIZATION SETTING

Command Name	Command Address	Parameter (1 or 2Byte)	Remarks
Software Reset	01		
Dot Matrix Display ON/OFF	02	00	Note 1
Read/Write Operation Wetting	07	00	Note 1
Display Direction Set Command	09	00	Note 1
Reserved 1	10	03	Note 2
Reserved 2	12	63	Note 2
Reserved 3	13	00	Note 2
Dot Matrix Display Standby ON/OFF	14	00	
Reserved 4	16	00	Note 2
Reserved 5	17	00	Notes 1 & 2
Reserved 6	18	09	Note 2
Reserved 7	1A	04	Notes 1 & 2
Reserved 8	1C	00	Notes 1 & 2
Graphic Memory Writing Direction	1D	00	Note 1
Setting Column Output Range	30	005F	Note 1
Setting Row Output Range	32	003F	Note 1
X Axis Reading/Writing Start Point	34	00	Note 1
X Axis Reading/Writing End Point	35	0F	Note 1
Y Axis Reading/Writing Start Point	36	00	Note 1
Y Axis Reading/Writing End Point	37	3F	Note 1

Notes: 1. Same as default value
2. Do not change setting value

Command Name	Command Address	Parameter (1 or 2Byte)	Remarks
X Axis Reading Start Address	38	00	Note 1
Y Axis Reading Start Address	39	00	Note 1
Reserved 9	48	03	Note 2
Screen Saver Event Timer Setting Command	C3	00	Note 1
Screen Saver Event Timer Setting Command	C4	00	Note 1
One Time, Repeat or Direction Setting for Screen Saver	CC	00	Note 1
Start/Stop Setting for Screen Saver	CD	00	Note 1
System Clock Division Ratio Setting	D0	80	Note 2
Setting the STBY Pin	D2	00	Notes 1 & 2
DACA Setting	D4	00	Notes 1 & 2
DACB Setting	D5	00	Notes 1 & 2
DACC Setting	D6	00	Notes 1 & 2
DACD Setting	D7	00	Notes 1 & 2
Reserved 10	D9	00	Notes 1 & 2
Dimmer Setting	DB	0F	Note 1
Reserved 11	DD	88	Note 2
Image Writing	08	Image data	

Notes: 1. Same as default value
2. Do not change setting value

DEVELOPMENT TOOLS

NKK Switches offers a variety of development tools. These tools include software that may be downloaded from www.nkksmartswitch.com.

In addition to standard configurations, NKK can provide custom solutions for the most complex design challenges. Contact factory for information and support regarding your custom applications.

Development Kits provide a full set of tools for designs. The Dev Kits enable rapid prototype designs so that feedback is easily obtained. NKK's Development Kits have been designed to facilitate the creation, testing and displaying of images with software downloaded from www.nkksmartswitch.com. Click on "Download Software."

PRECAUTIONS FOR HANDLING & STORAGE

Handling



1. OLED devices are electrostatic sensitive.
2. Signal input under conditions not recommended may cause damage to the OLED unit or deterioration of the display. Follow directions regarding supply sequences of power and signal voltages.
3. If the OLED panel is broken, avoid touching the contents. Wash off in case of contact to the skin or clothing.
4. Limit operating force to 100.0N maximum, as excessive pressure may damage the display.
5. Under certain actuation conditions, one side of the rocker and the center switch can both send actuation signals.
6. Pixels acquire diminished brightness over time and use, and those most frequently habituated have greater reduction of brightness than those less used. To minimize this difference, operate OLED unit so that all pixels are used as consistently as possible.
7. Clean actuator surface with dry cloth. If further cleaning is needed, wipe with dampened cloth using neutral cleanser and dry with clean cloth. Do not use organic solvent.

Storage

1. Store in original container and away from direct sunlight.
2. Keep away from static electricity.
3. Avoid extreme temperatures, high humidity, gaseous substances, and all forms of chemical contamination.

Panel Mounting

- Before snapping a switch into the panel, align the gasket evenly under the bezel of the switch.
- When mounting into a panel, apply equal pressure to sides of bezel and insert parallel to the panel.
- After mounting, be sure there are no gaps between switch and panel. Lightly push into panel.
- After installing into panel, do not apply excessive force.
- After panel installation and wiring is completed, do not apply force horizontally or vertically from behind panel.
- Behind the panel, cut area should be squared. If front of panel is painted, do not allow any paint to collect in corners of cutout to prevent level mounting.
- Avoid reinstalling a switch once it has been mounted into panel. This may cause deterioration of panel sealability.

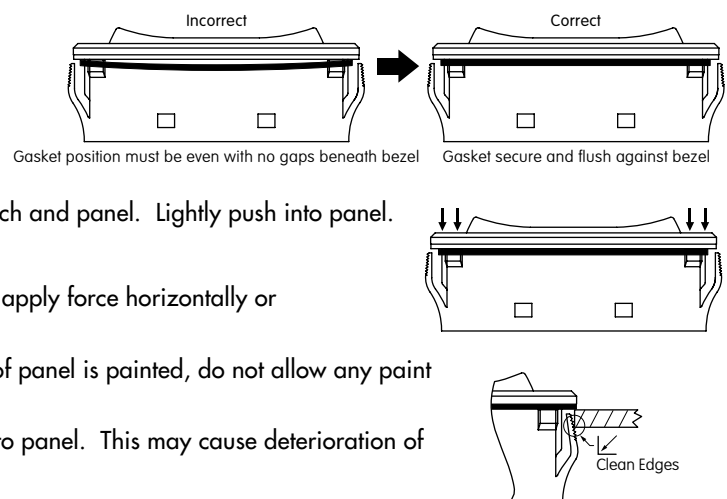



Компания «ЭлектроПласт» предлагает заключение долгосрочных отношений при поставках импортных электронных компонентов на взаимовыгодных условиях!

Наши преимущества:

- Оперативные поставки широкого спектра электронных компонентов отечественного и импортного производства напрямую от производителей и с крупнейших мировых складов;
- Поставка более 17-ти миллионов наименований электронных компонентов;
- Поставка сложных, дефицитных, либо снятых с производства позиций;
- Оперативные сроки поставки под заказ (от 5 рабочих дней);
- Экспресс доставка в любую точку России;
- Техническая поддержка проекта, помощь в подборе аналогов, поставка прототипов;
- Система менеджмента качества сертифицирована по Международному стандарту ISO 9001;
- Лицензия ФСБ на осуществление работ с использованием сведений, составляющих государственную тайну;
- Поставка специализированных компонентов (Xilinx, Altera, Analog Devices, Intersil, Interpoint, Microsemi, Aeroflex, Peregrine, Syfer, Eurofarad, Texas Instrument, Miteq, Cobham, E2V, MA-COM, Hittite, Mini-Circuits, General Dynamics и др.);

Помимо этого, одним из направлений компании «ЭлектроПласт» является направление «Источники питания». Мы предлагаем Вам помощь Конструкторского отдела:

- Подбор оптимального решения, техническое обоснование при выборе компонента;
- Подбор аналогов;
- Консультации по применению компонента;
- Поставка образцов и прототипов;
- Техническая поддержка проекта;
- Защита от снятия компонента с производства.



Как с нами связаться

Телефон: 8 (812) 309 58 32 (многоканальный)

Факс: 8 (812) 320-02-42

Электронная почта: org@eplast1.ru

Адрес: 198099, г. Санкт-Петербург, ул. Калинина, дом 2, корпус 4, литера А.