

**Vectron International**

**Filter specification**

**TFS433AK**

**1/5**

**Measurement condition**

Ambient temperature $T_A$ :	23	°C
Input power level:	0	dBm
Terminating impedance:		
Input:	50	$\Omega$
Output:	50	$\Omega$

**Characteristics**

Remark:

The reference level for the relative attenuation  $a_{rel}$  of the TFS433AK is the minimum of the pass band attenuation. This value is defined as the insertion loss  $a_e$ . The nominal frequency  $f_N$  is fixed at 433.92 MHz without any tolerance. The values of relative attenuation  $a_{rel}$  are guaranteed over the whole operating temperature range. The frequency shift of the filter within the operating temperature range is included in the production tolerance scheme.

<b>D a t a</b>	<b>typ. value</b>		<b>tolerance / limit</b>	
<b>Insertion loss</b>	$a_e$	2.75 dB	3.80 dB	
(reference level)		-	-	
<b>Nominal frequency</b>	$f_N$	-	433.92 MHz	
<b>Centre frequency</b>	$f_C$	433.96 MHz	-	
<b>Passband</b>	PB			
1 dB		6.4 MHz	min.	1.71 MHz
<b>Relative attenuation</b>	$a_{rel}$			
$f_N - 0.92$ MHz ... $f_N + 0.79$ MHz		0.4 dB	max.	1 dB
$f_N - 8.42$ MHz ... $f_N - 18.92$ MHz		58 dB	min.	37 dB
$f_N - 18.92$ MHz ... $f_N - 25.92$ MHz		63 dB	min.	52 dB
$f_N - 25.92$ MHz ... $f_N - 40.92$ MHz		65 dB	min.	42 dB
$f_N - 40.92$ MHz ... $f_N - 83.92$ MHz		74 dB	min.	52 dB
$f_N - 83.92$ MHz ... $f_N - 423.92$ MHz		71 dB	min.	37 dB
$f_N + 9.58$ MHz ... $f_N + 20.08$ MHz		26 dB	min.	12 dB
$f_N + 20.08$ MHz ... $f_N + 41.08$ MHz		55 dB	min.	34 dB
$f_N + 41.08$ MHz ... $f_N + 141.08$ MHz		68 dB	min.	50 dB
$f_N + 141.08$ MHz ... $f_N + 566.08$ MHz		50 dB	min.	40 dB
<b>Input power level</b>		-	max.	5 dBm
<b>Operating temperature range</b>	OTR	-	- 40 °C ... + 85 °C	
<b>Storage temperature range</b>		-	- 55 °C ... + 125 °C	
<b>Temperature coefficient of frequency</b>	$TC_f$ *)	-35 ppm/K	-	

\*)  $\Delta f = TC_f(T - T_A)f_N$

**Generated:**

---

**Checked / Approved:**

---

**Vectron International GmbH**  
**Potsdamer Straße 18**  
**D 14 513 TELTOW / Germany**  
**Tel: (+49) 3328 4784-0 / Fax: (+49) 3328 4784-30**  
**E-Mail: [tft@vectron.com](mailto:tft@vectron.com)**

Vectron International GmbH reserves the right to make changes to the product(s) and/or information contained herein without notice. No liability is assumed as a result of their use or application. No rights under any patent accompany the sale of any such product(s) or information.

**Filter characteristic**

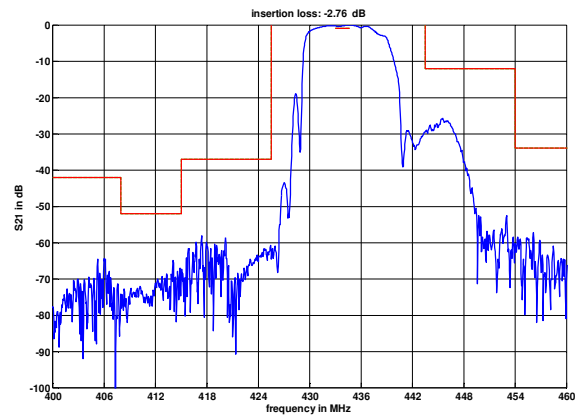
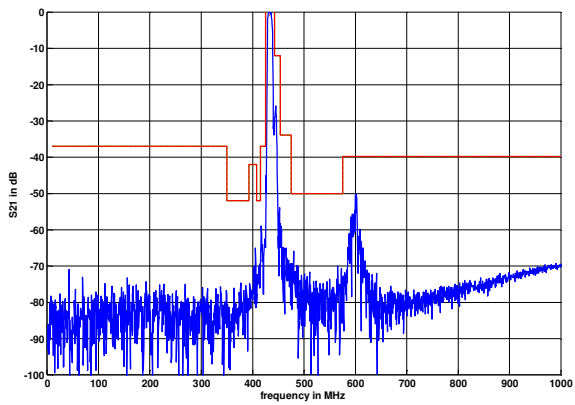

**Construction and pin connection**

(All dimensions in mm)

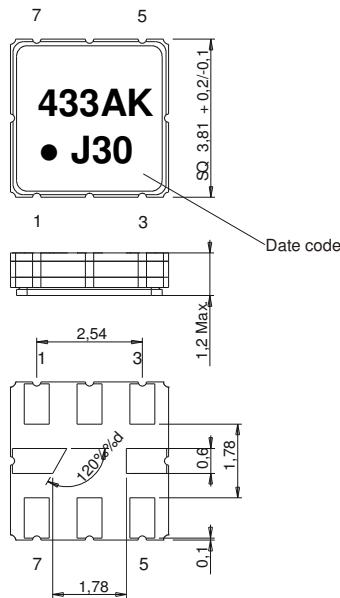

- 1 Ground
- 2 Output
- 3 Ground
- 4 Ground
- 5 Ground
- 6 Input
- 7 Ground
- 8 Ground

Date code: Year + week  
 J 2017  
 K 2018  
 L 2019  
 ...

**50 Ohm Test circuit**

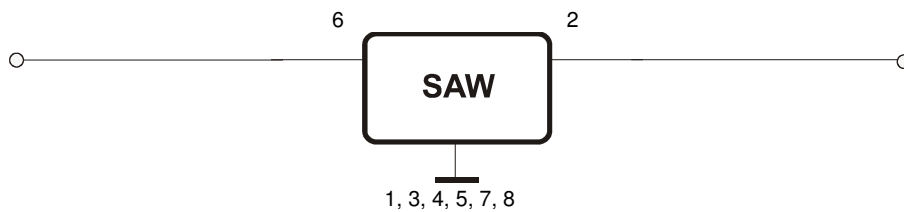

**Vectron International GmbH**  
 Potsdamer Straße 18  
 D 14 513 TELTOW / Germany  
 Tel: (+49) 3328 4784-0 / Fax: (+49) 3328 4784-30  
 E-Mail: [tft@vectron.com](mailto:tft@vectron.com)

Vectron International GmbH reserves the right to make changes to the product(s) and/or information contained herein without notice. No liability is assumed as a result of their use or application. No rights under any patent accompany the sale of any such product(s) or information.

**Stability characteristics, reliability**

After the following tests the filter shall meet the whole specification:

1. Shock: 500 g, 1 ms, half sine wave, 3 shocks each plane;  
DIN IEC 60068 T2 - 27
2. Vibration: 10 Hz to 2000 Hz, 0.35 mm or 5 g respectively, 1 octave per min, 10 cycles per plane, 3 planes; DIN IEC 60068 T2 - 6
3. Change of temperature: -55 °C to 125 °C / 15 min. each / 100 cycles  
DIN IEC 60068 part 2 – 14 Test N
4. Resistance to solder heat (reflow): reflow possible: three times max.;  
for temperature conditions refer to the attached "Air reflow temperature conditions" on page 4;
5. SAW devices are Electrostatic Discharge (ESD) sensitive devices.

This filter is RoHS compliant (2011/65/EU)

**Packing**

Tape & Reel: IEC 286 – 3, with exception of value for N and minimum bending radius;  
tape type II, embossed carrier tape with top cover tape on the upper side;

reel of empty components at start:	min. 300 mm
reel of empty components at start including leader:	min. 500 mm
trailer:	min. 300 mm

**Tape (all dimensions in mm)**

- W : 12.00 ±0.3
- Po : 4.00 ±0.1
- Do : 1.50 +0.1/-0
- E : 1.75 ±0.1
- F : 5.50 ±0.05
- G(min) : 0.75
- P2 : 2.00 ±0.05
- P1 : 8.00 ±0.1
- D1(min) : 1.50
- Ao : 4.30 ±0.1
- Bo : 4.30 ±0.1
- Ct : 9.2 ±0.1
- Ko : 1.80 ±0.1
- t : 0.30 ±0.05

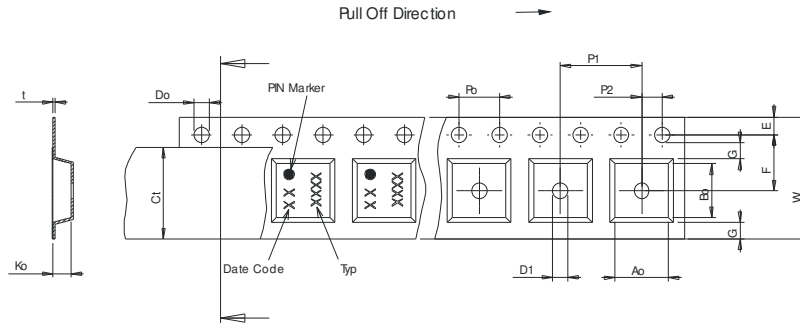

**Reel (all dimensions in mm)**

- A : 330 or 180
- W1 : 12.4 +2/-0
- W2(max) : 18.40
- N(min) : 50.00
- C : 13.0 +0.5/-0.2

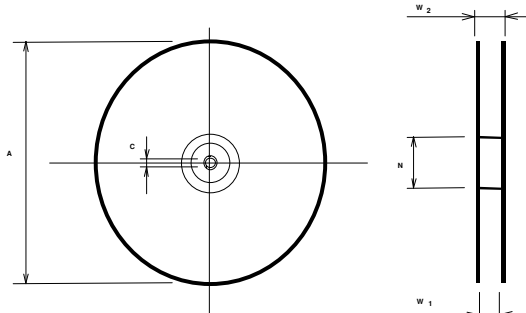

The minimum bending radius is 45 mm.

**Vectron International GmbH**  
**Potsdamer Straße 18**  
**D 14 513 TELTOW / Germany**  
**Tel: (+49) 3328 4784-0 / Fax: (+49) 3328 4784-30**  
**E-Mail: [tft@vectron.com](mailto:tft@vectron.com)**

Vectron International GmbH reserves the right to make changes to the product(s) and/or information contained herein without notice. No liability is assumed as a result of their use or application. No rights under any patent accompany the sale of any such product(s) or information.

## Air reflow temperature conditions

Conditions	Exposure
Average ramp-up rate (30 °C to 217 °C)	less than 3 °C / second
> 100 °C	between 300 and 600 seconds
> 150 °C	between 240 and 500 seconds
> 217 °C	between 30 and 150 seconds
Peak temperature	max. 260 °C
Time within 5 °C of actual peak temperature	between 10 and 30 seconds
Cool-down rate (Peak to 50 °C)	less than 6 °C / second
Time from 30 °C to Peak temperature	no greater than 300 seconds

Chip-mount air reflow profile

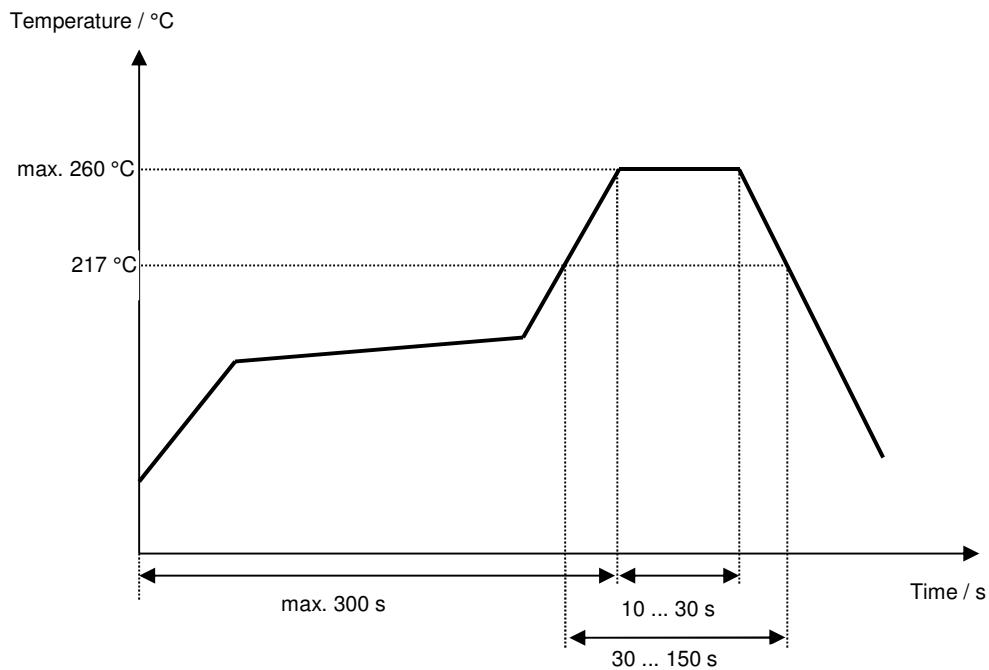

**History**

<b>Version</b>	<b>Reason of Changes</b>	<b>Name</b>	<b>Date</b>
1.0	Generation of filter specification.	Abutaimah	09.03.2017
1.1	Update storage temperature range Update construction and pin connection Update 50 $\Omega$ test circuit Update tape & reel Update typos	P. Jaster	27.07.2017



Компания «ЭлектроПласт» предлагает заключение долгосрочных отношений при поставках импортных электронных компонентов на взаимовыгодных условиях!

Наши преимущества:

- Оперативные поставки широкого спектра электронных компонентов отечественного и импортного производства напрямую от производителей и с крупнейших мировых складов;
- Поставка более 17-ти миллионов наименований электронных компонентов;
- Поставка сложных, дефицитных, либо снятых с производства позиций;
- Оперативные сроки поставки под заказ (от 5 рабочих дней);
- Экспресс доставка в любую точку России;
- Техническая поддержка проекта, помощь в подборе аналогов, поставка прототипов;
- Система менеджмента качества сертифицирована по Международному стандарту ISO 9001;
- Лицензия ФСБ на осуществление работ с использованием сведений, составляющих государственную тайну;
- Поставка специализированных компонентов (Xilinx, Altera, Analog Devices, Intersil, Interpoint, Microsemi, Aeroflex, Peregrine, Syfer, Eurofarad, Texas Instrument, Miteq, Cobham, E2V, MA-COM, Hittite, Mini-Circuits, General Dynamics и др.);

Помимо этого, одним из направлений компании «ЭлектроПласт» является направление «Источники питания». Мы предлагаем Вам помощь Конструкторского отдела:

- Подбор оптимального решения, техническое обоснование при выборе компонента;
- Подбор аналогов;
- Консультации по применению компонента;
- Поставка образцов и прототипов;
- Техническая поддержка проекта;
- Защита от снятия компонента с производства.



#### Как с нами связаться

**Телефон:** 8 (812) 309 58 32 (многоканальный)

**Факс:** 8 (812) 320-02-42

**Электронная почта:** [org@eplast1.ru](mailto:org@eplast1.ru)

**Адрес:** 198099, г. Санкт-Петербург, ул. Калинина, дом 2, корпус 4, литера А.