



# TAOGLAS®



## Datasheet

### Meteor

**Part No:**  
FW.86.B.NTY.M

### Description:

Meteor-868MHz Flexible Whip Monopole Antenna

### Features:

External 868MHz Monopole Antenna  
Rugged Design for Outdoor Use  
Robust Inner Steel Core  
Antenna Height 243mm  
N Type(M) Straight Connector  
IP65 dust and water-resistant  
\*Tested on 30\*30cm Ground Plane  
RoHS Compliant

1. Introduction	3
2. Specifications	4
3. Antenna Characteristics	5
4. Radiation Patterns	7
5. Mechanical Drawing	9
6. Packaging	10
<hr/>	
Changelog	11

Taoglas makes no warranties based on the accuracy or completeness of the contents of this document and reserves the right to make changes to specifications and product descriptions at any time without notice. Taoglas reserves all rights to this document and the information contained herein. Reproduction, use or disclosure to third parties without express permission is strictly prohibited.



## 1. Introduction



The FW.86 is a flexible 868MHz whip antenna with an N type(M) connector for outdoor use. It features excellent efficiency and high peak gain at 868MHz on a 30\*30cm ground plane.

The antenna was specifically developed for applications such as weather monitoring systems, motion/vibration sensors, pollution monitoring, and border guard monitoring systems.

The FW.86 works at 868MHz with high efficiency, meaning that it allows your radio to consume less power than with a lower efficiency antenna when transferring data.

The whip is made of a flexible inner steel core covered by PE so it is extremely resistant to abrasion and maintains its original shape and RF performance. This rugged design and IP65 rating has been tested by our customers to withstand environmental stress and moderate physical shock in the field.

The FW.86.B.NTY.M 868MHz whip antenna, with an N type male connector, provides a simple solution to any outdoor devices where the FW.86 antenna's rugged design and high efficiency can provide the best value to the application.

## 2. Specifications

<b>FW.86.B.NTY.M</b>			
Center Frequency	850MHz	868MHz	890MHz
Efficiency	67.52%	70.60%	67.54%
Peak Gain	1.82dBi	2.82dBi	3.58dBi
Average Gain	-1.71dB	-1.51dB	-1.70dB
Impedance	50Ω		
Polarization	Linear		
Radiation Pattern	Omnidirectional		
Input Power	2 W		
Tested Power	10 W		
<b>Mechanical</b>			
Dimensions	243 ± 5.3mm		
Base Diameter	20 ± 0.6mm		
Whip Diameter	6.2 ± 0.6mm		
Casing	ABS		
Connector	N Type(M) Straight		
Weight	48.5g		
Dust and Water Resistance	IP65		
<b>Environmental</b>			
Temperature Range	-40°C to 85°C		
Humidity	Non-condensing 65°C 95% RH		

### 3. Antenna Characteristics

#### 3.1 Return Loss

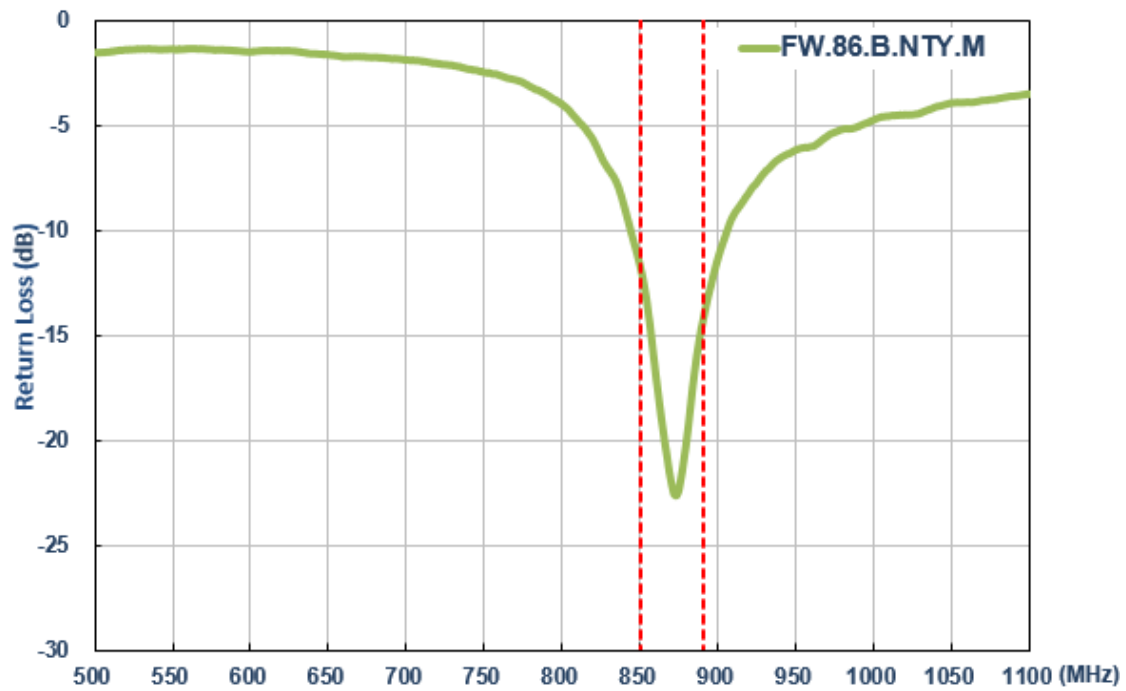

#### 3.2 Efficiency

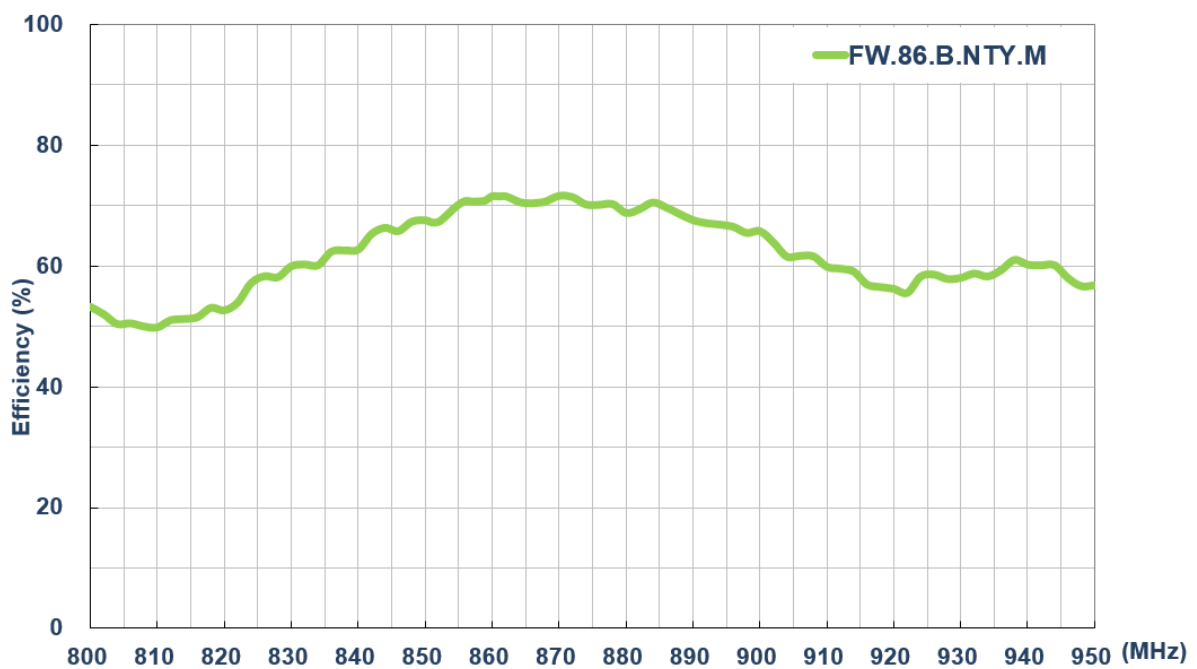

### 3.3 Peak Gain

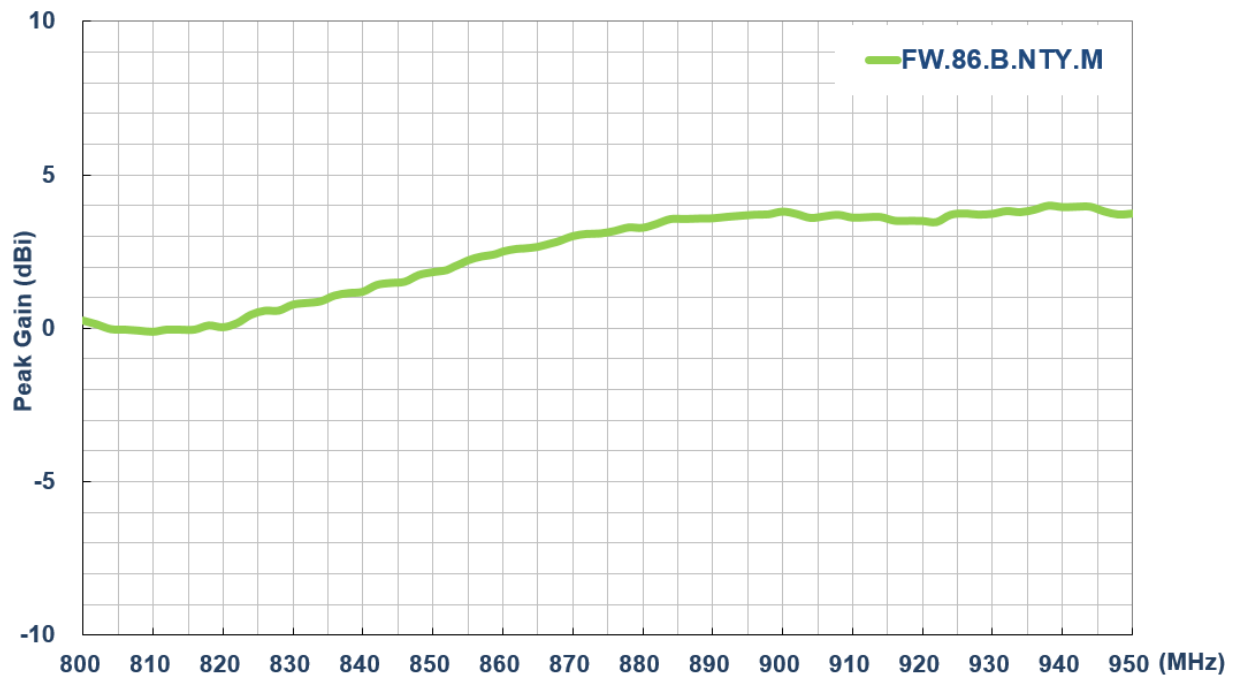

### 3.4 Average Gain

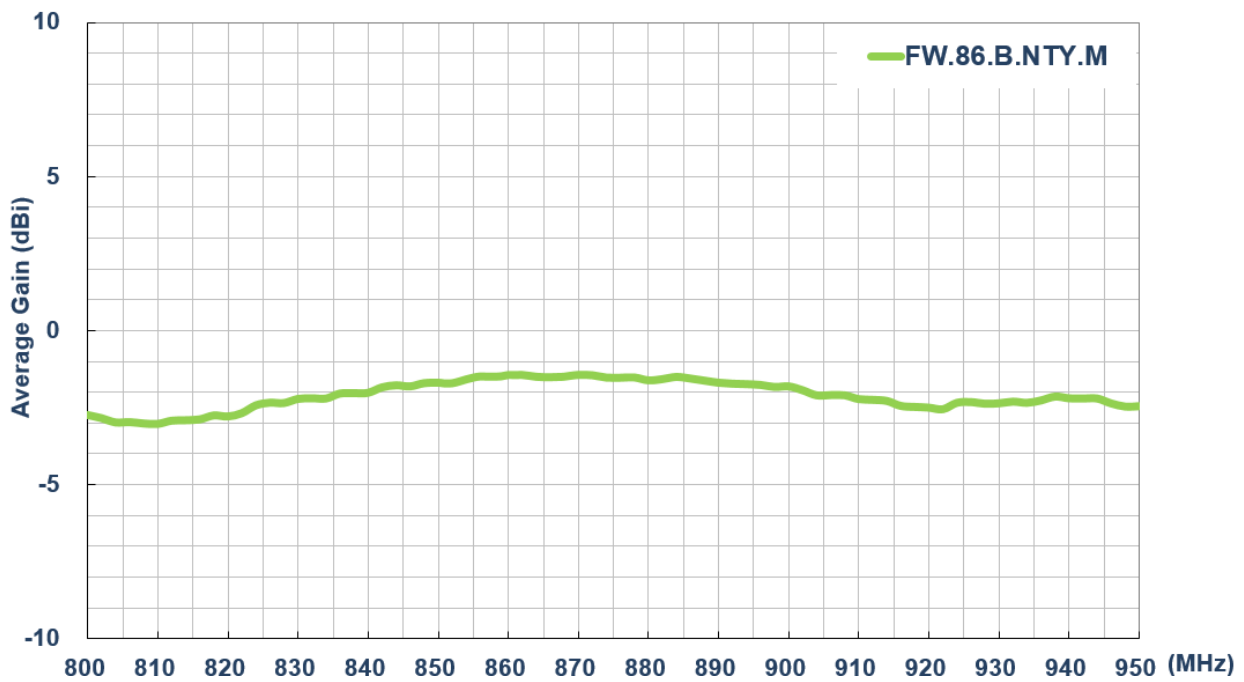

## 4. Radiation Patterns

### 4.1 Test Setup

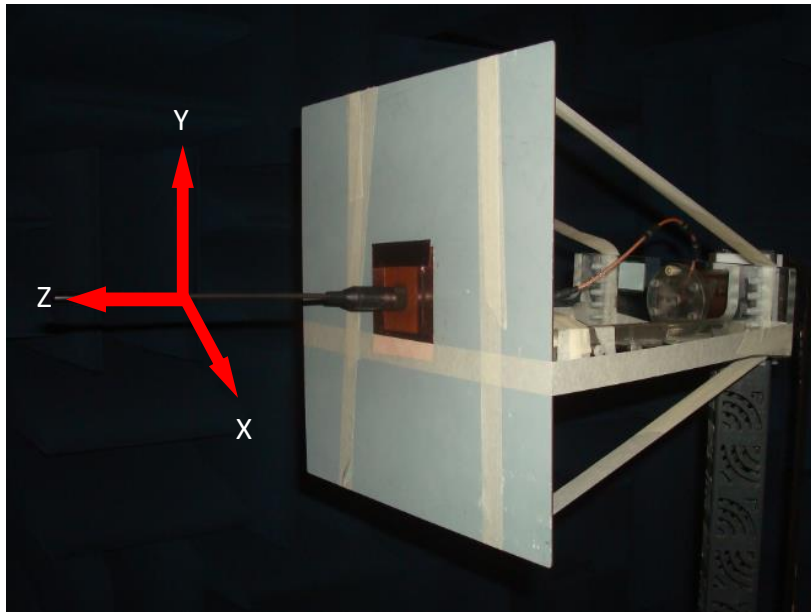

On 30x30 cm ground plane

4.2 3D and 2D Radiation Patterns (On 30cm\*30cm Ground Plane)

XY Plane

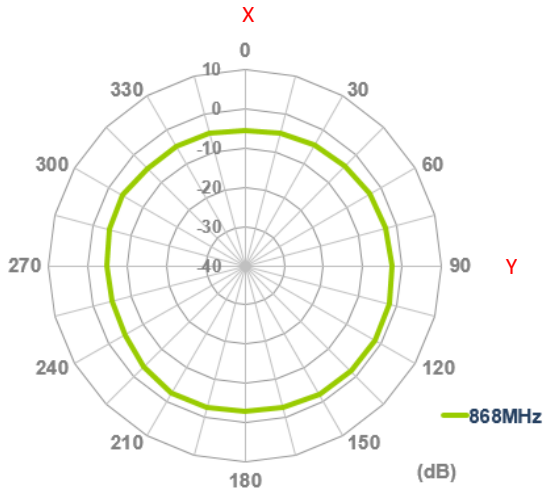

XZ Plane

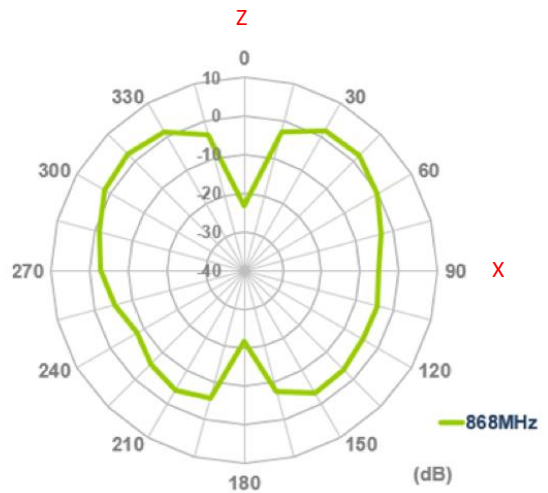

YZ Plane

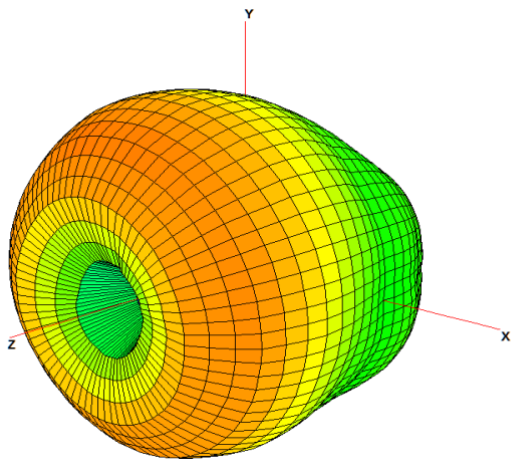
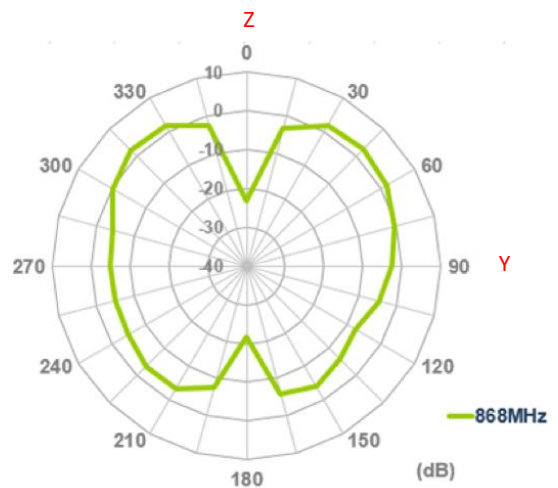

3D Radiation Pattern @ 868MHz



## 5. Mechanical Drawing (Units: mm)

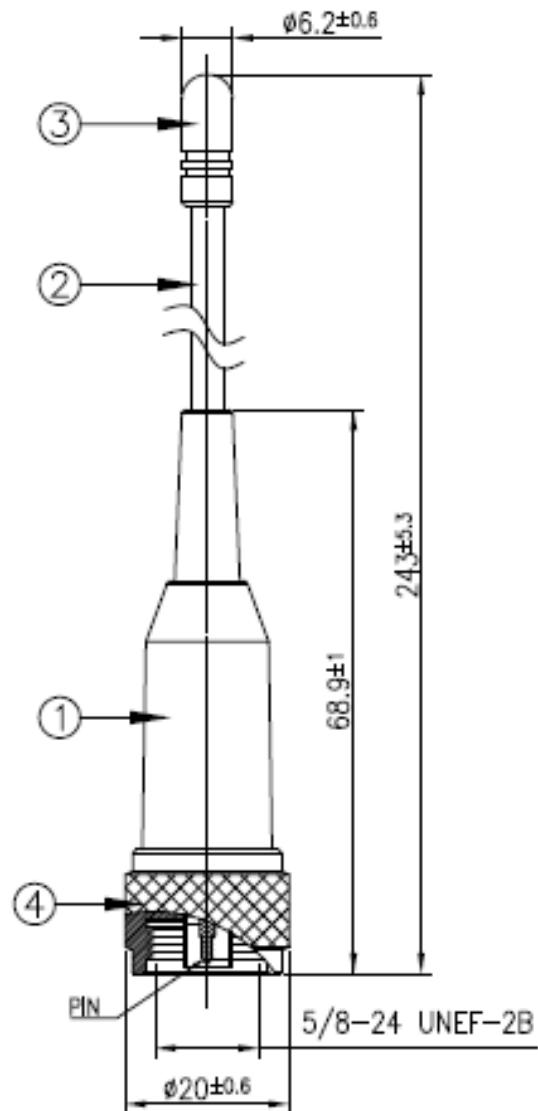

	Name	P/N	Material	Finish	QTY
1	Housing	000113A000002A	ABS	Black	1
2	Flexible Whip	001113A000002A	Steel+PE Jacket	Black	1
3	Cap	000713A000002A	POM	Black	1
4	N Type (M)ST	211014A000002A	Brass	Black	1

## 6. Packaging

1pcs FW.86.B.NTY.M per PE Bag  
 Bag Dimensions - 50\*370mm  
 Weight - 40g

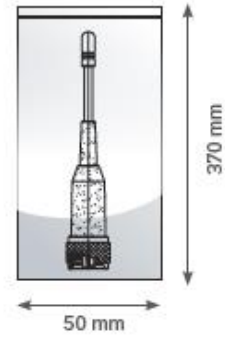

50 PE Bags per Large PE Bag  
 50 pcs FW.86.B.NTY.M per Large PE Bag  
 Large PE Bag Dimensions - 360\*520mm  
 Weight - 2.5Kg

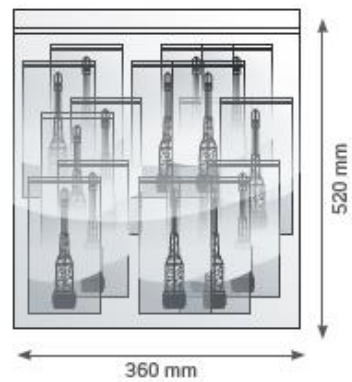

150 pcs FW.86.B.NTY.M per Carton  
 Carton Dimensions - 360\*310\*160mm  
 Weight - 7.5Kg

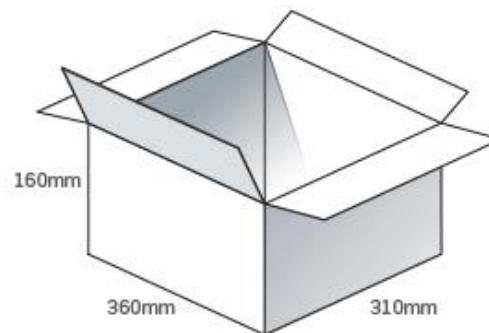

Pallet Dimensions:  
 120\*100\*148cm  
 72 Cartons Per Pallet  
 12 Cartons Per Layer  
 6 Layers

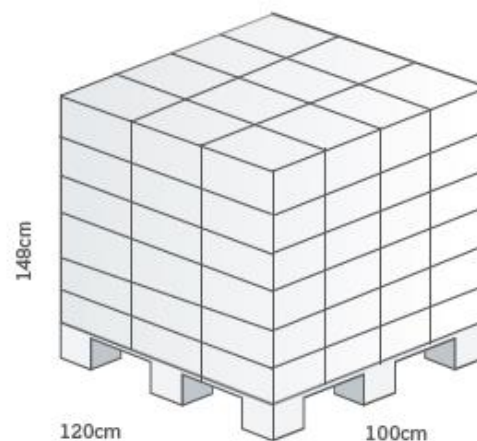

Changelog for the datasheet

**SPE-16-8-080 - FW.86.B.NTY.M**

<b>Revision: B</b>	
Date:	2019-08-16
Changes:	Updated to new format
Changes Made by:	Dan Cantwell

**Previous Revisions**

<b>Revision: A (Original First Release)</b>	
Date:	2016-12-20
Notes:	
Author:	Andy Mahoney



**TAOGLAS**®

[www.taoglas.com](http://www.taoglas.com)





Компания «ЭлектроПласт» предлагает заключение долгосрочных отношений при поставках импортных электронных компонентов на взаимовыгодных условиях!

Наши преимущества:

- Оперативные поставки широкого спектра электронных компонентов отечественного и импортного производства напрямую от производителей и с крупнейших мировых складов;
- Поставка более 17-ти миллионов наименований электронных компонентов;
- Поставка сложных, дефицитных, либо снятых с производства позиций;
- Оперативные сроки поставки под заказ (от 5 рабочих дней);
- Экспресс доставка в любую точку России;
- Техническая поддержка проекта, помощь в подборе аналогов, поставка прототипов;
- Система менеджмента качества сертифицирована по Международному стандарту ISO 9001;
- Лицензия ФСБ на осуществление работ с использованием сведений, составляющих государственную тайну;
- Поставка специализированных компонентов (Xilinx, Altera, Analog Devices, Intersil, Interpoint, Microsemi, Aeroflex, Peregrine, Syfer, Eurofarad, Texas Instrument, Miteq, Cobham, E2V, MA-COM, Hittite, Mini-Circuits, General Dynamics и др.);

Помимо этого, одним из направлений компании «ЭлектроПласт» является направление «Источники питания». Мы предлагаем Вам помощь Конструкторского отдела:

- Подбор оптимального решения, техническое обоснование при выборе компонента;
- Подбор аналогов;
- Консультации по применению компонента;
- Поставка образцов и прототипов;
- Техническая поддержка проекта;
- Защита от снятия компонента с производства.



#### Как с нами связаться

**Телефон:** 8 (812) 309 58 32 (многоканальный)

**Факс:** 8 (812) 320-02-42

**Электронная почта:** [org@eplast1.ru](mailto:org@eplast1.ru)

**Адрес:** 198099, г. Санкт-Петербург, ул. Калинина, дом 2, корпус 4, литера А.