

# TREK-674

## Compact In-Vehicle Computing Box for Fleet Management and Surveillance



### Features

- Vehicle diagnostics interface with configurable CAN (J1939, OBD-II/ISO 15765) and J1708 (J1587) protocols
- Embedded Stretch S7 video encoder supports up to 8 analog video inputs and 4 audio inputs
- Built-in GNSS, WLAN, Bluetooth, and WWAN (with dual SIM cards) modules
- Intelligent vehicle power management system supports ignition on/off/delay functions, wake-up event control, and system health monitoring and diagnostics
- Accessible external SSD tray with key-lock protection
- Wide operating temperature range (-30 ~ 70 °C/-22 ~ 158 °F)
- Supports 12/24 V vehicle power (ISO 7637-2)
- MIL-STD-810G and 5M3 certified for shock and vibration tolerance
- Easily paired with TREK in-vehicle smart displays (TREK-303/306) via a single-cable connection

### Introduction

TREK-674 is a compact vehicle-grade, dual-core computing box designed to provide high-quality video surveillance and fleet management for police, ambulance, fire engine, and bus fleets. The inclusion of GNSS, WLAN, Bluetooth, and WWAN (with dual SIM cards) modules allows remote monitoring and vehicle tracking even in tunnels. TREK-674 also features several vehicle protocols (J1939, OBD-II/ISO 15765) for vehicle diagnostics and driver behavior management, and supports up to 8 channel camera inputs for high-quality H.264 D1/30fps/ch recording. The USB 3.0 port, dual SIM card sockets, and CFast slots are front-facing to ensure ease of maintenance. Meanwhile an external swappable SSD tray is provided for video data backups.

### Specifications

Core	Processor	Intel® Atom™ E3827 (dual core, 1.75 GHz)
	Memory	1 x SODIMM socket Up to 8 GB DDR3L-1066/1333 non-ECC memory (2 GB default)
	Graphics	Integrated 2D/3D graphics engine
	Video HW Encoder	Stretch S7 with H.264 MJPEG support; up to D1 resolution (30fps) per channel
	Operating System	WES7, Win10 IoT LTSC (32 bit), WES8, and Linux Ubuntu 14.04 Kernel 3.19.0 (32 bit) upon request
Storage	CFast	1 x externally accessible CFast slot with cover and supports system boot up 16 GB, UMLC S0Flash CFast (default)
	SSD	1 x externally accessible 2.5" SSD tray with key-lock protection, supports system boot up 64 GB, UMLC S0Flash SSD (default)
Display	Smart Display Port <sup>1</sup>	12V/2A power output for TREK-30x 1 x 18-bit LVDS (800 x 480/1024 x 768 resolution with auto-detection) 1 x Line-Out2 (for TREK-30x speakers) 2 x UART (TX/RX, TX/RX/RTS) (for touchscreen, hot keys, brightness, and light sensor control) 1 x USB 2.0 Type A 1 x PWR button 1 x Reset button
	VGA	1 x DB15 (up to 2560 x 1600 resolution)
I/O	Vehicle I/O	2 x CAN bus (supports raw CAN, J1939, OBD-II/ISO 15765; configurable via firmware) 1 x J1708 (supports J1587)
	Generic I/O	1 x RS-485 with auto flow control 1 x 4-wire RS-232 4 x Isolated DI (dry contact) 2 x Isolated DO (open collector output, driven by relay) 1 x Line-Out <sup>2</sup> 1 x Mic-In
	Standard I/O	1 x USB 3.0 Type A (front) 2 x USB 2.0 Type A (rear, with cable clip) 1 x High-speed full RS-232, DB-9 (Pin 9 = ring, 12/5 V @0.5A is BOM optional via jumper setting) 2 x Giga LAN, with locked-type RJ45 connector
RF	Video/Audio Input (Via DVI-I Connector)	8 x Video inputs with video compression, H.264, MJPEG support, and up to D1 resolution (30fps) per channel 4 x Audio inputs with G.711 audio compression
	LED Indicators	5 x LEDs: Power (red), Storage (yellow), WLAN (green), WWAN (green), and GPS (yellow)
	Power Button	Via TREK-30x in-vehicle smart display; system power on by ignition as default
	Reset Button	1 x Reset button (front)
	WLAN + Bluetooth	IEEE 802.11a/b/g/n + Bluetooth V4.0 combo module via full-size mini PCIe slot (Optional high-power WLAN/WLAN for roaming available upon request)
Power	WWAN	4G (LTE, HSPA+, GSM/GPRS/EDGE, EV-DO Rev a1, 1xRTT); Sierra Wireless MC73xx via full-size mini-PCIe slot (MC7354 for US/MC7304 for EU as default) 2 x external accessible mini-SIM card sockets (selectable) with cover
	GNSS	Built-in u-blox MAX-M8W GPS/GLONASS/BeiDou module with A-GPS support (Optional LEA-6R or Neo-M8L (dead reckoning) available upon request)
	Antenna	4 x SMA-type antenna holes for GPS, Wi-Fi+BT, WWAN/LTE MIMO <sup>3</sup>
	Voltage input	Supports 12/24 V vehicle power, 9 ~ 32 V <sub>DC</sub> input (ISO 7637-2 and SAE J1113 compliant)
Mechanical	Intelligent Vehicle Power Management (IVPM 2.0)	System power on/off/hibernate management (programmable ignition on/off/delay) Supports wake-up events: wake-on-alarm (RTC), wake-on-call/SMS, and wake-on-G-sensor System power protection (vehicle battery low voltage protection) System monitoring and diagnostics
	Dimensions (W x H x D) Weight	294 x 73 x 184 mm (11.57 x 2.87 x 7.24 in) 3.5 kg (7.71 lb)

<sup>1</sup> For direct pairing with TREK-303/306 via a single-cable connection

<sup>2</sup> Supports dual independent audio streams (the Line-Out interfaces of the smart display and generic I/O are driven by different audio codecs)

<sup>3</sup> The TREK-674 connector type is female RP-SMA (e.g., a female connector body (outside threads) with a male inner pin contact)

## Specifications Cont.

Environment	IP Rating	IP30
	Vibration/Shock	MIL-STD-810G, EN60721-3(5M3)
	EMC	CE, FCC, CCC
	Safety	UL/cUL, CB
	Vehicle Regulation	E-Mark (E13), SAE J1455, ISO 7637-2, SAE J1113
	RF Regulation	CE (R&TTE), FCC ID
	Operating Temperature	-30 ~ 70 °C (-22 ~ 158 °F)
	Storage Temperature	-40 ~ 80 °C (-40 ~ 176 °F)

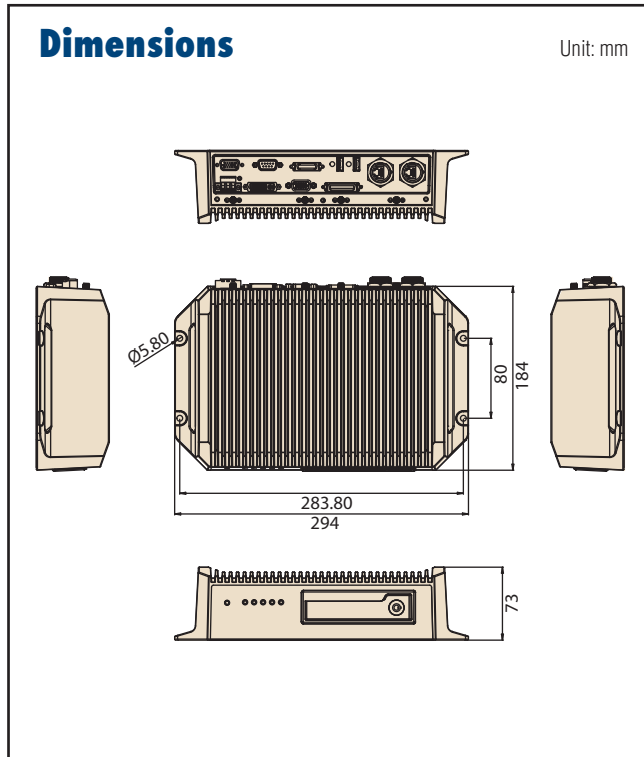

## I/O Connectors

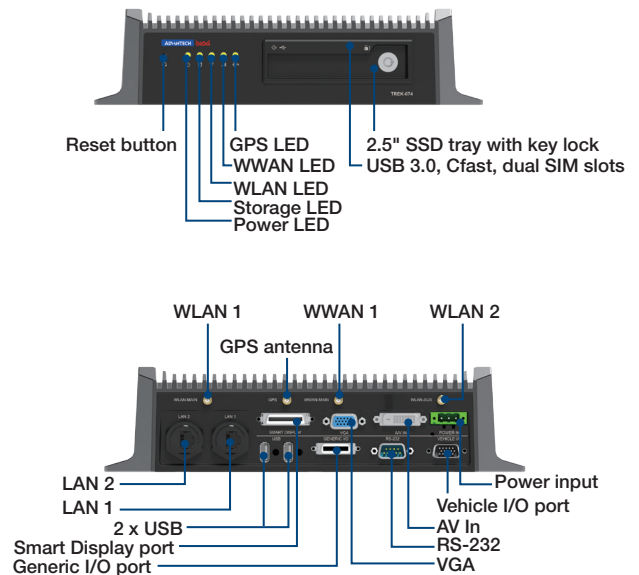

Note: WLAN 1 = WLAN main, WLAN 2 = WLAN auxiliary, WWAN 1 = WWAN main

## Ordering Information

Part Number	Description
TREK-674-LWB7A0E	TREK-674 w/LTE(EU)/GPS/WLAN/BT/SSD/WES7
TREK-674-LWB7B0E	TREK-674 w/LTE(US)/GPS/WLAN/BT/SSD/WES7

Note: WES8, Win10 IoT LTSB and Linux OS images are available upon request.

## Packing List

Part Number	Description
1700019031	1 x 2M power cable
1700023050-11	1 x generic I/O cable, 2M
1700023051-01	1 x vehicle I/O cable, 30 cm
1700022702-01	1 x Audio/Video cable, 20 cm
1654011716-01	2 x waterproof RJ45 locking kit
1750007724-01	1 x 3-in-1 antenna (LTE/GPS/Wi-Fi), 3M
1750007723-01	1 x Wi-Fi only antenna, 3M
1990018848T000	2 x USB cable clips

## Optional Accessories

Part Number	Description
TREK-303R-HA0E	7" WVGA in-vehicle smart display
TREK-306D-HA0E	10" WVGA in-vehicle smart display
1700020007-11	2M smart display cable
1700020008	5M smart display cable
1700020128	5M power cable
1700019464	Power cable, 155 mm (for in-house testing)
96PSA-A60W12V1-1	Adapter AC 100 ~ 240 V, 60 W, 12 V 5A w/o PFC (for in-house testing)



Компания «ЭлектроПласт» предлагает заключение долгосрочных отношений при поставках импортных электронных компонентов на взаимовыгодных условиях!

Наши преимущества:

- Оперативные поставки широкого спектра электронных компонентов отечественного и импортного производства напрямую от производителей и с крупнейших мировых складов;
- Поставка более 17-ти миллионов наименований электронных компонентов;
- Поставка сложных, дефицитных, либо снятых с производства позиций;
- Оперативные сроки поставки под заказ (от 5 рабочих дней);
- Экспресс доставка в любую точку России;
- Техническая поддержка проекта, помощь в подборе аналогов, поставка прототипов;
- Система менеджмента качества сертифицирована по Международному стандарту ISO 9001;
- Лицензия ФСБ на осуществление работ с использованием сведений, составляющих государственную тайну;
- Поставка специализированных компонентов (Xilinx, Altera, Analog Devices, Intersil, Interpoint, Microsemi, Aeroflex, Peregrine, Syfer, Eurofarad, Texas Instrument, Miteq, Cobham, E2V, MA-COM, Hittite, Mini-Circuits, General Dynamics и др.);

Помимо этого, одним из направлений компании «ЭлектроПласт» является направление «Источники питания». Мы предлагаем Вам помощь Конструкторского отдела:

- Подбор оптимального решения, техническое обоснование при выборе компонента;
- Подбор аналогов;
- Консультации по применению компонента;
- Поставка образцов и прототипов;
- Техническая поддержка проекта;
- Защита от снятия компонента с производства.



#### Как с нами связаться

**Телефон:** 8 (812) 309 58 32 (многоканальный)

**Факс:** 8 (812) 320-02-42

**Электронная почта:** [org@eplast1.ru](mailto:org@eplast1.ru)

**Адрес:** 198099, г. Санкт-Петербург, ул. Калинина, дом 2, корпус 4, литера А.