

# SFH551/1-1

## SFH551/1-1V

Integrated Photo Detector Receiver for Plastic Fiber  
Plastic Connector Housing



## Data Sheet

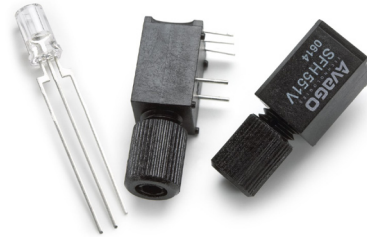

### Description

The SFH551/1V is a transimpedance amplifier with digital TTL open collector output stage and integrated photodiode. The active area of the detector in connection with the molded microlens gives an efficient coupling from the end of a plastic fiber.

The receiver is fully DC coupled and therefore no line code is needed.

The SFH551/1V includes a Schmitt trigger function to provide stable output states over the whole dynamic range. For optical input power levels above  $6 \mu\text{W}$  typically the electrical output will be logical "low" and vice versa. With noise free Vcc and GND no undefined output signal is possible. SFH551/1 must not be used without shielding the ambient light, because ambient light causes malfunction when reaching the threshold level, noise or complete switching the output. Interference free transmission is possible by using the SFH551/1V with the black plastic connector housing.

### Ordering Information

Type	Ordering Code
SFH551/1-1	SP000063860
SFH551/1-1V	SP000063855

### Features

- Bipolar IC with open-collector output
- Digital output, TTL compatible
- Sensitive in visible and near IR range
- Low switching threshold
- Transfer rate  $\leq 5 \text{ Mbit/s}$
- 2.2 mm aperture holds standard 1000 micron plastic fiber
- No fiber stripping required
- Molded microlens for efficient coupling

### Plastic Connector Housing

- Mounting screw attached to the connector
- Interference-free transmission from light-tight housing
- Transmitter and receiver can be flexibly positioned
- No cross talk
- Auto insertable and wave solderable
- Supplied in tubes

### Applications

- Household electronics
- Power electronics
- Optical networks

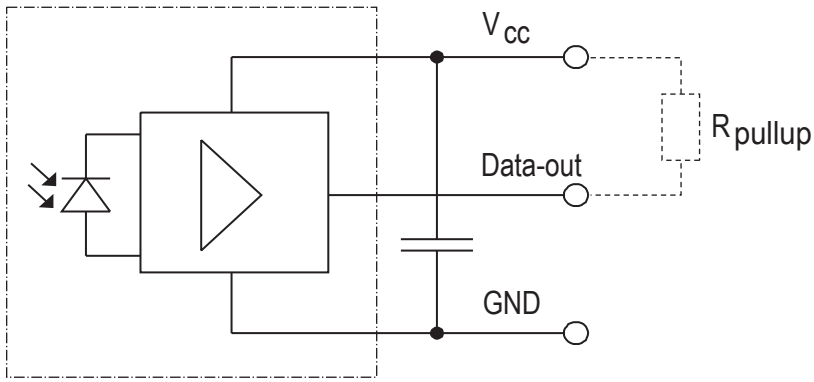

**Figure 1. Block Diagram**

A bypass capacitor (100 nF) near the device (distance  $\leq 3$  cm) is necessary between ground and  $V_{CC}$ . In critical applications the distance may be shorter.

## Technical Data

### Absolute Maximum Ratings

Parameter	Symbol	Limit Values		Unit
		min.	max.	
Operating Temperature Range	$T_{OP}$	-40	+85	$^{\circ}C$
Storage Temperature Range	$T_{STG}$	-40	+100	$^{\circ}C$
Soldering Temperature(2mm from case bottom, $t \leq 5$ s)	$T_S$		260	$^{\circ}C$
Supply Voltage Range without Damage	$V_{CC}$	-0.5	15	V
Recommended and Guaranteed Maximum Voltage			5.5	V
Minimum Supply Voltage for Function	$V_{CCmin}$	4		V
Minimum Pull-up Resistance( $V_{CC} = 5$ V)	$R_{outmin}$	330		$\Omega$
Output Voltage	$V_O$	-0.5	15	V
Output Current	$I_O$		50	mA
Power Dissipation (output)	$P_O$		100	mW

### Characteristics ( $T_A = 25^{\circ}C$ , $V_{CC} = 4.75$ to $5.25$ V)

Parameter	Symbol	Values			Unit
		min.	typ.	max.	
Maximum Photosensitivity Wavelength	$\lambda_{Smax}$		700		nm
Photosensitivity Spectral Range ( $S = 80\% S_{max}$ )	$\lambda$	600		780	nm
SFH551/1-1 OpticalThreshold Power ( $\lambda = 660$ nm) for Output Low	$\Phi_{INth}$		$\geq 6$ $\geq -22$		$\mu W$ dBm
Maximum Optical Power ( $\lambda = 660$ nm)	$\Phi_{INL}$		1000		$\mu W$
Maximum Value of tPLH at Maximum Power			0		dBm
Optical Power for Output High without Errors ( $\lambda = 660$ nm)	$\Phi_{INH}$		$\leq 0.1$ $\leq -40$		$\mu W$ dBm
Propagation Delay (optical input to electrical output, with fast optical pulse)	$t_{PHL}$ $t_{PLH}$		$< 100$ $< 250$		ns
Current Consumption (without output current)	$I_{CC}$		4		mA

## Package Outlines

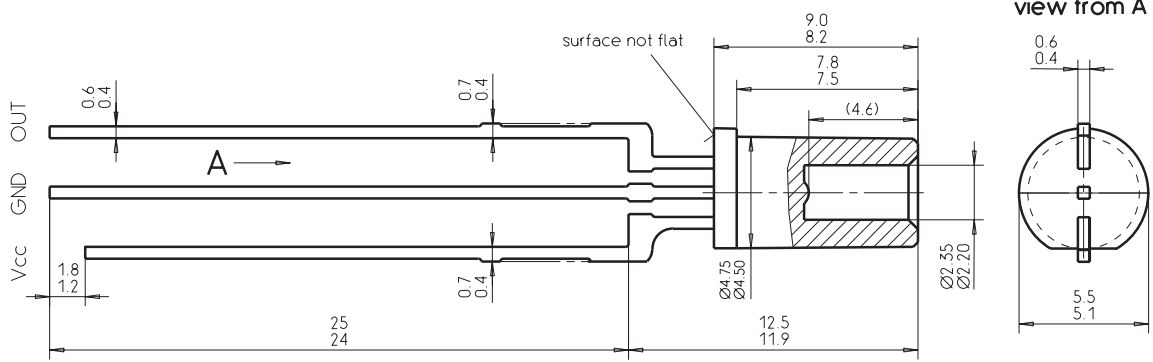

Dimensions in mm

Figure 2. SFH551/1-1

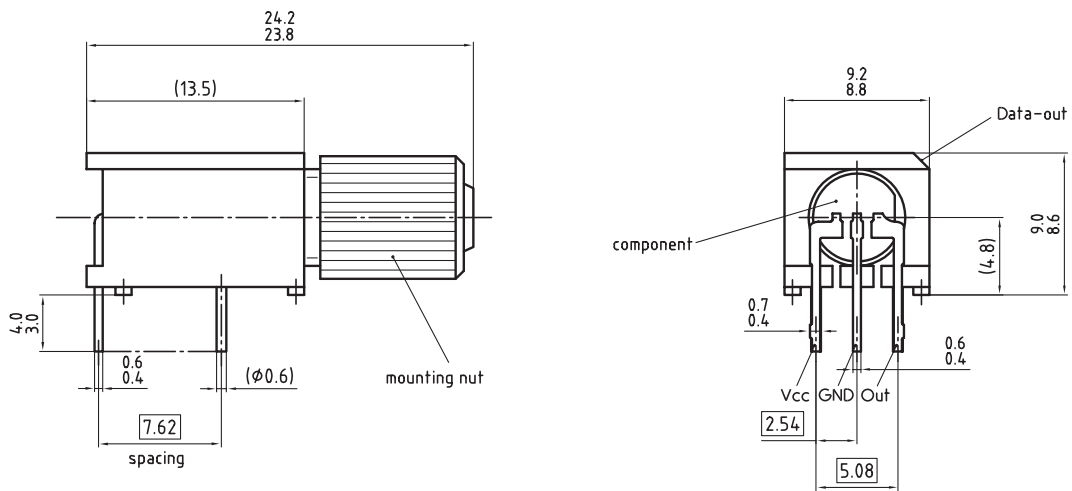

Dimensions in mm

Figure 3. SFH551/1-1V

## **Disclaimer**

The information herein is given to describe certain components and shall not be considered as a guarantee of characteristics.

Terms of delivery and rights to technical change reserved. We hereby disclaim any and all warranties, including but not limited to warranties of non-infringement, regarding circuits, descriptions and charts stated herein.

## **Warnings**

Due to technical requirements components may contain dangerous substances. For information on the types in question please contact your nearest Avago Technologies Office.

Avago Technologies Components may only be used in life-support devices or systems with the express written approval of Avago Technologies, if a failure of such components can reasonably be expected to cause the failure of that life-support device or system, or to affect the safety or effectiveness of that device or system. Life support devices or systems are intended to be implanted in the human body, or to support and/or maintain and sustain and/or protect human life. If they fail, it is reasonable to assume that the health of the user or other persons maybe endangered.

## **Information**

For further information on technology, delivery terms and conditions and prices please contact your nearest Avago Technologies Office ([www.avagotech.com](http://www.avagotech.com)).

For product information and a complete list of distributors, please go to our web site: [www.avagotech.com](http://www.avagotech.com)

Avago, Avago Technologies, and the A logo are trademarks of Avago Technologies, Limited in the United States and other countries.  
Data subject to change. Copyright © 2007 Avago Technologies Limited. All rights reserved.  
AV01-0713EN - July 20, 2007

**Avago**  
TECHNOLOGIES



Компания «ЭлектроПласт» предлагает заключение долгосрочных отношений при поставках импортных электронных компонентов на взаимовыгодных условиях!

Наши преимущества:

- Оперативные поставки широкого спектра электронных компонентов отечественного и импортного производства напрямую от производителей и с крупнейших мировых складов;
- Поставка более 17-ти миллионов наименований электронных компонентов;
- Поставка сложных, дефицитных, либо снятых с производства позиций;
- Оперативные сроки поставки под заказ (от 5 рабочих дней);
- Экспресс доставка в любую точку России;
- Техническая поддержка проекта, помощь в подборе аналогов, поставка прототипов;
- Система менеджмента качества сертифицирована по Международному стандарту ISO 9001;
- Лицензия ФСБ на осуществление работ с использованием сведений, составляющих государственную тайну;
- Поставка специализированных компонентов (Xilinx, Altera, Analog Devices, Intersil, Interpoint, Microsemi, Aeroflex, Peregrine, Syfer, Eurofarad, Texas Instrument, Miteq, Cobham, E2V, MA-COM, Hittite, Mini-Circuits, General Dynamics и др.);

Помимо этого, одним из направлений компании «ЭлектроПласт» является направление «Источники питания». Мы предлагаем Вам помощь Конструкторского отдела:

- Подбор оптимального решения, техническое обоснование при выборе компонента;
- Подбор аналогов;
- Консультации по применению компонента;
- Поставка образцов и прототипов;
- Техническая поддержка проекта;
- Защита от снятия компонента с производства.



#### Как с нами связаться

**Телефон:** 8 (812) 309 58 32 (многоканальный)

**Факс:** 8 (812) 320-02-42

**Электронная почта:** [org@eplast1.ru](mailto:org@eplast1.ru)

**Адрес:** 198099, г. Санкт-Петербург, ул. Калинина, дом 2, корпус 4, литера А.