

POWER RELAY

1 POLE—20A (Contact Gap 3.0mm type)

FTR-K2G SERIES

RoHS compliant

■ FEATURES

- Contact gap min. 3.0mm
- Full disconnection
- 1 Pole, 1 Form A
- Maximum inrush current 120A (TV-8)
- HIGH INSULATION
Reinforced insulation
Insulation Distance between coil and contact:
 - Clearance min. 8.0mm, Creepage min. 9.5mm
 - Dielectric Strength: 5KV
 - Surge Strength: 10KV
- HEAT RESISTANCE, FLAMMABILITY
Class B (130°C) coil insulation, flammability UL94V-0 (plastic)
- SAFETY STANDARDS
UL, CSA, VDE approved
- RoHS compliant
Please see page 7 for more information



■ ORDERING INFORMATION

[Example] FTR-K2G A K 012 T
 (a) (b)(c) (d) (e)

(a)	Series name	FTR-K2G		
(b)	Contact arrangement	A: 1 Form A (SPST-NO)		
(c)	Coil type	K: Standard (1000mW)		
(d)	Coil nominal voltage	005 : 5VDC 006 : 6VDC 009 : 9VDC	012 : 12VDC 018 : 18VDC 024 : 24VDC	048 : 48VDC 060 : 60VDC 110 : 110VDC
(e)	Contact material	T: AgSnO ₂ (TV-8)		

Actual marking does not carry the type name : "FTR"
 E.g.: Ordering code: FTR-K2GAK012T Actual marking: -K2GAK012T

FTR-K2G Series

■ PART NUMBERS

Standard type: 1000mW

Ordering Part Number	Series	Contact	Coil Voltage	Contact Material
FTR-K2GAK005T	FTR-K2G	1 form A	5	T: AgSnO ₂ (TV-8 rated)
FTR-K2GAK006T			6	
FTR-K2GAK009T			9	
FTR-K2GAK012T			12	
FTR-K2GAK018T			18	
FTR-K2GAK022T			22	
FTR-K2GAK024T			24	
FTR-K2GAK048T			48	
FTR-K2GAK060T			60	
FTR-K2GAK110T			110	

■ COIL DATA CHART

Standard Type 1000mW

Coil Voltage	Nominal Voltage (VDC)	Max. Coil Voltage* ¹	Coil Resistance (±10%)	Must Operate Voltage* ²	Must Release Voltage* ²	Nominal Power (mW)
005	5	8.5 VDC	25 Ω	3.25 VDC	0.25 VDC	1,000
006	6	10.2 VDC	36 Ω	3.9 VDC	0.3 VDC	
009	9	15.3 VDC	81 Ω	5.85 VDC	0.45 VDC	
012	12	20.4 VDC	145 Ω	7.8 VDC	0.6 VDC	
018	18	30.6 VDC	325 Ω	11.7 VDC	0.9 VDC	
022	22	37.4 VDC	485 Ω	14.3 VDC	1.1 VDC	
024	24	40.8 VDC	580 Ω	15.6 VDC	1.2 VDC	
048	48	81.6 VDC	2,200Ω	31.2 VDC	2.4 VDC	1,050
060	60	102.0 VDC	3,600Ω	39.0 VDC	3.0 VDC	1,000
110	110	187.0 VDC	13,000 Ω	71.5 VDC	5.5 VDC	930

Note: All values at 20°C.

*1: No contact current at 20°C. Please see 'operating range' data for other conditions.

*2: Specified values are subject to pulse shape voltage

FTR-K2G Series

■ SPECIFICATIONS

Item		FTR-K2G2AK ()T	
Contact	Arrangement	1 form A (SPST-NO)	
	Material	AgSnO ₂	
	Resistance (initial)	Maximum 100 mΩ (at 6VDC, 1A)	
	Rating (resistive)	20A / 250 VAC	
	Maximum Carrying Current* ¹	25A	
	Maximum Switching Power	5000VA	
	Maximum Switching Voltage	440VAC	
	Minimum Switching Load* ²	100 mA, 5 VDC (reference value)	
Coil	Nominal Power (20°C)	Approximately 1000 mW	
	Operate Power (20°C)	Approximately 420 mW	
	Operating Temperature	-40°C to +70°C (no frost)	
Time Value	Operate Time (at nominal voltage)	Maximum 30 ms (without bounce)	
	Release Time (without diode)	Maximum 15 ms	
Life	Mechanical	1 x 10 ⁶ operations minimum	
	Electrical	Resistive	100 x 10 ³ operations min.
		Lamp load (TV-8)	25 x 10 ³ operations minimum
Other	Vibration Resistance	Misoperation	10 to 55 Hz, at double amplitude of 1.5 mm
		Endurance	10 to 55Hz, at double amplitude of 1.5 mm
	Shock Resistance	Misoperation	100m/s ² (11±1ms)
		Endurance	1,000m/s ² (6±1ms)
	Weight	Approximately 34g	

*¹ Need to consider the heat when mounted on PCB at carry currents > 10A. Please confirm at actual condition.

*² Minimum switching loads mentioned above are reference values. Please perform the confirmation test with the actual load before production since reference values may vary according to switching frequencies, environmental conditions and expected reliability levels.

FTR-K2G Series

■ INSULATION

Item	FTR-K2G	Note
Resistance	Minimum 1,000 MΩ	at 500 VDC
Dielectric Strength	between open contacts	2,000 VAC (50/60 Hz) 1 min.
	between coil and contacts	5,000 VAC (50/60 Hz) 1 min.
Surge Voltage (between coil and contact)	10,000 V	1.2 x 50μs standard wave
Clearance/Creepage distance	8.0mm / 9.5mm	
Insulation (DIN EN61810-1 VDE0435)		
Voltage	250 V	
Pollution	3	
Isolation material group	III a	

■ SAFETY STANDARDS

Type	Compliance	Compliance rating
UL	UL 508 CSA22.2 No.14 UL/CSA60950-1 E63614	Flammability: UL 94-V0 (plastics) 20A, 277VAC (resistive) TV-8, 120 VAC
VDE	0435, 0631, 0700, 0860 400 22822	20A, 250 VAC (cosφ=1) 70°C 100k operations 8/120A, 250VAC 70°C 30k operations

■ PACKAGING

Package	MOQ	Weight of relay
Tube	200 pieces	Approximately 34 g

FTR-K2G Series

CHARACTERISTIC DATA

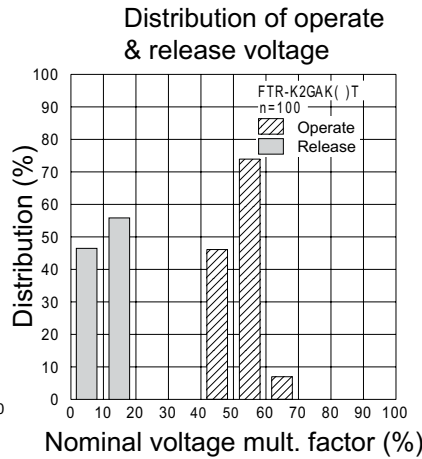
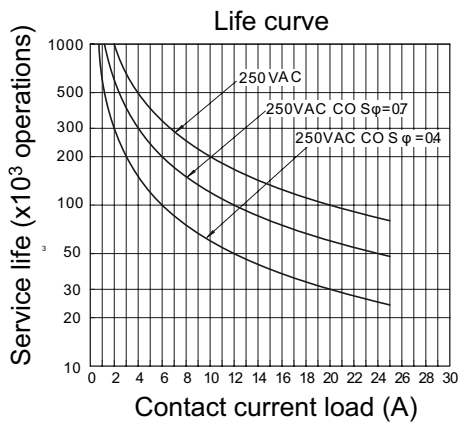
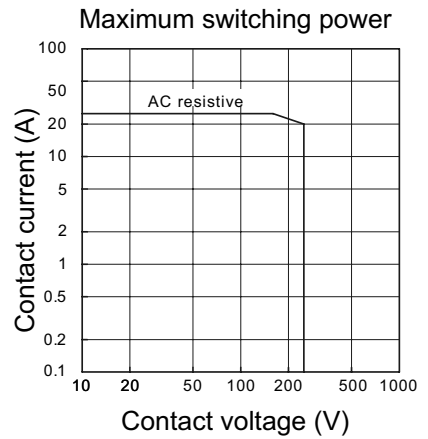
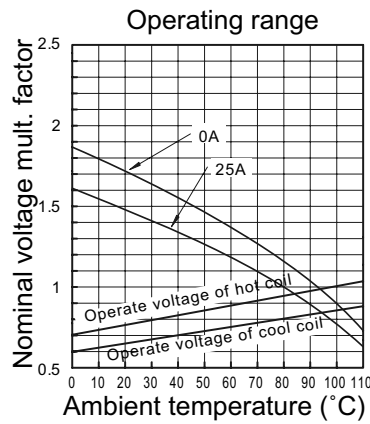
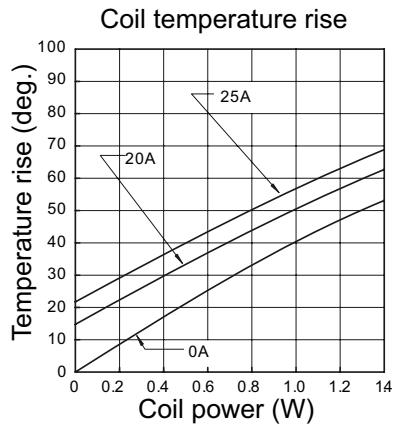

REFERENCE DATA

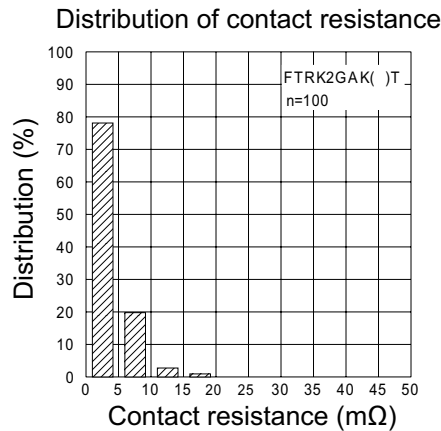
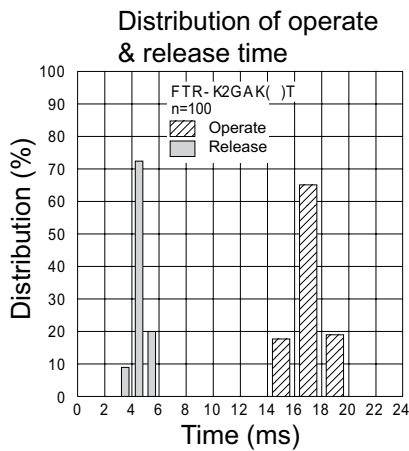

FTR-K2G Series

■ DIMENSIONS

● Dimensions

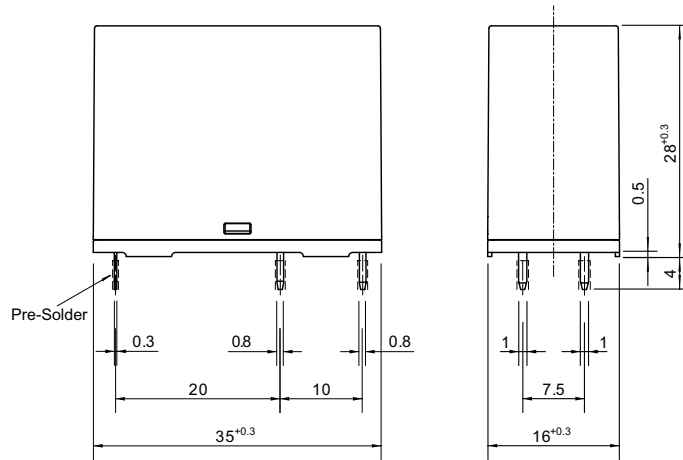

● Schematics (BOTTOM VIEW)

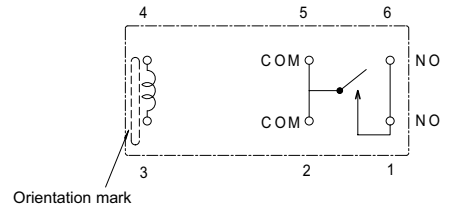

● PC board mounting hole layout (BOTTOM VIEW)

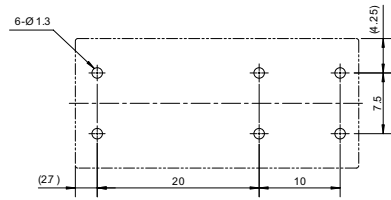

Unit: mm

RoHS Compliance and Lead Free Relay Information

1. General Information

- Relays produced after the specific date code that is indicated on each data sheet are lead-free now. All of our signal and power relays are lead-free. Please refer to Lead-Free Status Info. (<http://www.fujitsu.com/us/downloads/MICRO/fcai/relays/lead-free-letter.pdf>)
- Lead free solder paste currently used in relays is Sn-3.0Ag-0.5Cu.
- All signal and power relays also comply with RoHS. Please refer to individual data sheets. Relays that are RoHS compliant do not contain the 5 hazardous materials that are restricted by RoHS directive (lead, mercury, chromium IV, PBB, PBDE).
- It has been verified that using lead-free relays in leaded assembly process will not cause any problems (compatible).
- "LF" is marked on each outer and inner carton. (No marking on individual relays).

Note: Cadmium was exempted from RoHS on October 21, 2005. (Amendment to Directive 2002/95/EC)

2. Recommended Lead Free Solder Profile

- Recommended solder paste Sn-3.0Ag-0.5Cu.

Solder condition

Flow Solder condition:

Pre-heating: maximum 120°C
Soldering: dip within 5 sec. at
260°C solder bath

Solder by Soldering Iron:

Soldering Iron
Temperature: maximum 360°C
Duration: maximum 3 sec.

We highly recommend that you confirm your actual solder conditions

3. Moisture Sensitivity

- Moisture Sensitivity Level standard is not applicable to electromechanical relays.

4. Tin Whisker

- Dipped SnAgCu solder is known as low risk tin whisker. No considerable whisker length was found by our in house test.

Fujitsu Components International Headquarter Offices

Japan

Fujitsu Component Limited
Gotanda-Chuo Building
3-5, Higashigotanda 2-chome, Shinagawa-ku
Tokyo 141, Japan
Tel: (81-3) 5449-7010
Fax: (81-3) 5449-2626
Email: promothq@ft.ed.fujitsu.com
Web: www.fcl.fujitsu.com

North and South America

Fujitsu Components America, Inc.
250 E. Caribbean Drive
Sunnyvale, CA 94089 U.S.A.
Tel: (1-408) 745-4900
Fax: (1-408) 745-4970
Email: components@us.fujitsu.com
Web: <http://www.fujitsu.com/us/services/edevices/components/>

Europe

Fujitsu Components Europe B.V.
Diamantlaan 25
2132 WV Hoofddorp
Netherlands
Tel: (31-23) 5560910
Fax: (31-23) 5560950
Email: info@fceu.fujitsu.com
Web: emea.fujitsu.com/components/

Asia Pacific

Fujitsu Components Asia Ltd.
102E Pasir Panjang Road
#01-01 Citilink Warehouse Complex
Singapore 118529
Tel: (65) 6375-8560
Fax: (65) 6273-3021
Email: fcalfcal.fujitsu.com
Web: <http://www.fujitsu.com/sg/services/micro/components/>

©2008 Fujitsu Components America, Inc. All rights reserved. All trademarks or registered trademarks are the property of their respective owners.

Fujitsu Components America or its affiliates do not warrant that the content of datasheet is error free. In a continuing effort to improve our products Fujitsu Components America, Inc. or its affiliates reserve the right to change specifications/datasheets without prior notice.
Rev. October 29, 2008.



Компания «ЭлектроПласт» предлагает заключение долгосрочных отношений при поставках импортных электронных компонентов на взаимовыгодных условиях!

Наши преимущества:

- Оперативные поставки широкого спектра электронных компонентов отечественного и импортного производства напрямую от производителей и с крупнейших мировых складов;
- Поставка более 17-ти миллионов наименований электронных компонентов;
- Поставка сложных, дефицитных, либо снятых с производства позиций;
- Оперативные сроки поставки под заказ (от 5 рабочих дней);
- Экспресс доставка в любую точку России;
- Техническая поддержка проекта, помощь в подборе аналогов, поставка прототипов;
- Система менеджмента качества сертифицирована по Международному стандарту ISO 9001;
- Лицензия ФСБ на осуществление работ с использованием сведений, составляющих государственную тайну;
- Поставка специализированных компонентов (Xilinx, Altera, Analog Devices, Intersil, Interpoint, Microsemi, Aeroflex, Peregrine, Syfer, Eurofarad, Texas Instrument, Miteq, Cobham, E2V, MA-COM, Hittite, Mini-Circuits, General Dynamics и др.);

Помимо этого, одним из направлений компании «ЭлектроПласт» является направление «Источники питания». Мы предлагаем Вам помощь Конструкторского отдела:

- Подбор оптимального решения, техническое обоснование при выборе компонента;
- Подбор аналогов;
- Консультации по применению компонента;
- Поставка образцов и прототипов;
- Техническая поддержка проекта;
- Защита от снятия компонента с производства.



Как с нами связаться

Телефон: 8 (812) 309 58 32 (многоканальный)

Факс: 8 (812) 320-02-42

Электронная почта: org@eplast1.ru

Адрес: 198099, г. Санкт-Петербург, ул. Калинина, дом 2, корпус 4, литера А.