

Evaluation Board Manual

FEATURES

- High Output Voltage: up to 27V
- Drives up to 5 LEDs @ 20mA
- High Efficiency: up to 84%
- Integrated schottky diode
- Fast 1.0MHz Switching Frequency
- Low 0.2V Reference Voltage
- Output setpoint accuracy of 6%
- PWM Dimming Capable
- Small SOT23-6 Package
- Lead Free, RoHS Compliant Package

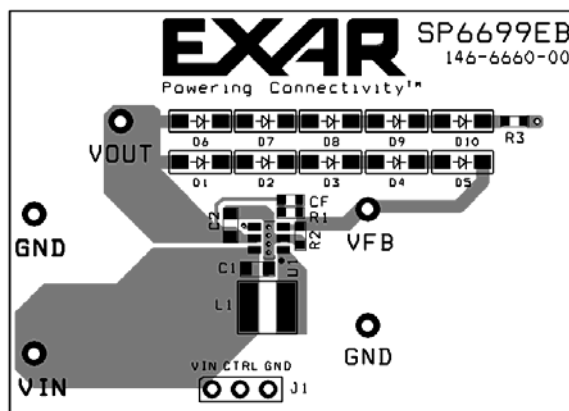

DESCRIPTION

The **SP6699 Evaluation Board** is designed to help the user evaluate the performance of the SP6699 for use as a LED Driver. The evaluation board is a completely assembled and tested surface mount board which provides easy probe access points to all SP6699 inputs and outputs so that the user can quickly connect and measure electrical characteristics and waveforms. The Evaluation Board schematic diagram is shown in Figure 1.

BOARD SCHEMATIC

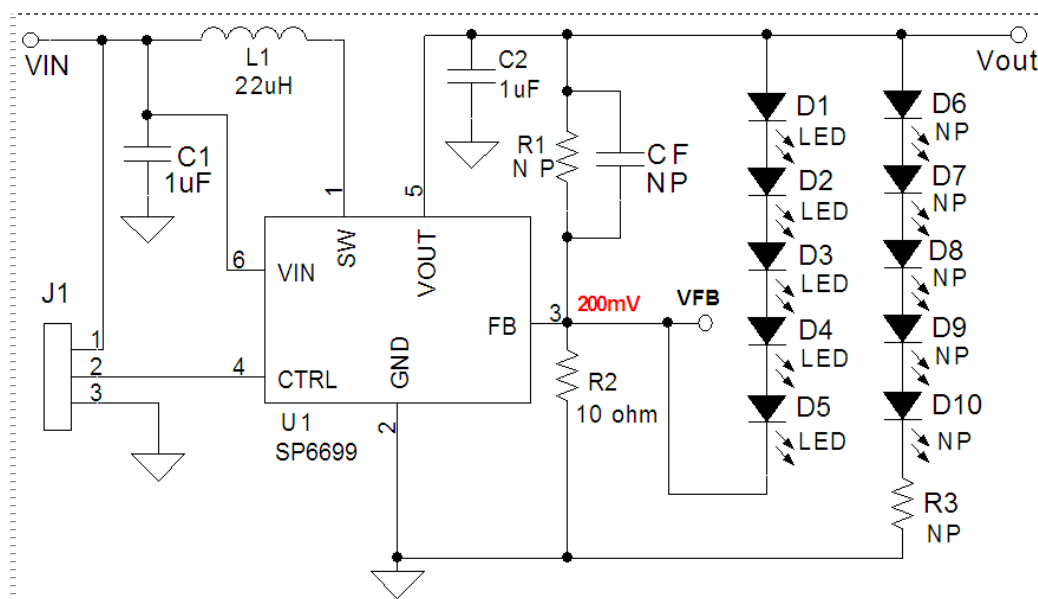

Figure 1. The SP6699 Evaluation Board Schematic Diagram

1) Powering Up the SP6699 Circuit

The SP6699 Evaluation Board can be powered from a 2.5V to 16V power supply. Connect the power supply with short leads directly to the “VIN” and “GND” posts.

2) Setting the output current

The typical SP6699EB configuration is for 5 WLEDs mounted in series and with the output current set for 20mA. Other LEDs could be externally connected but need to be connected anode to the VOUT pin and cathode to the Vfb pin. As many as 5 series connected LEDs may be used, depending on the input voltage range available. The total output current of the SP6699 is controlled by the VFB pin voltage setpoint of 200mV. Use a resistor at R2 to set the output current by the formula:

$$I_{out} = V_{fb}/R_2$$

Standard SP6699EB Evaluation Board Example:

$$I_{out} = V_{fb}/R_2 = 200mV/10ohm = 20mA$$

3) Dimming

The SP6699 can be pulse width modulated using a signal applied to the CTRL post. The CTRL signal will turn on the SP6699 when CTRL = H and turn-off the SP6699 when CTRL = L. The CTRL signal needs to be greater than 1.8V minimum to turn-on the SP6699 and less than 50mV to fully turn-off the SP6699. It is recommended to use a signal with CTRL = 1.8V or more for ON and 0V for OFF. Recommended modulation frequencies are from 100Hz to 200Hz.

4) Efficiency and Output Current

The SP6699 evaluation board efficiency is shown in figure 2 for 5 WLEDs at 20mA and 25mA. The efficiency is as high as 82% for 4.2V input which is very good for a high voltage boost regulator. The output current curves are shown in figure 3 and show that the output current remains very stable for a range of input voltage from 3V to 5V input.

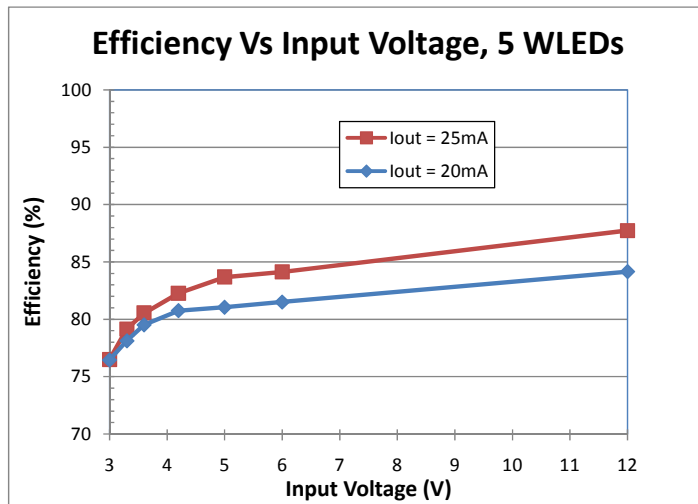

Figure 2. L1 = 22uH Efficiency Vs Input Voltage for 5 WLEDs at 20mA & 25mA

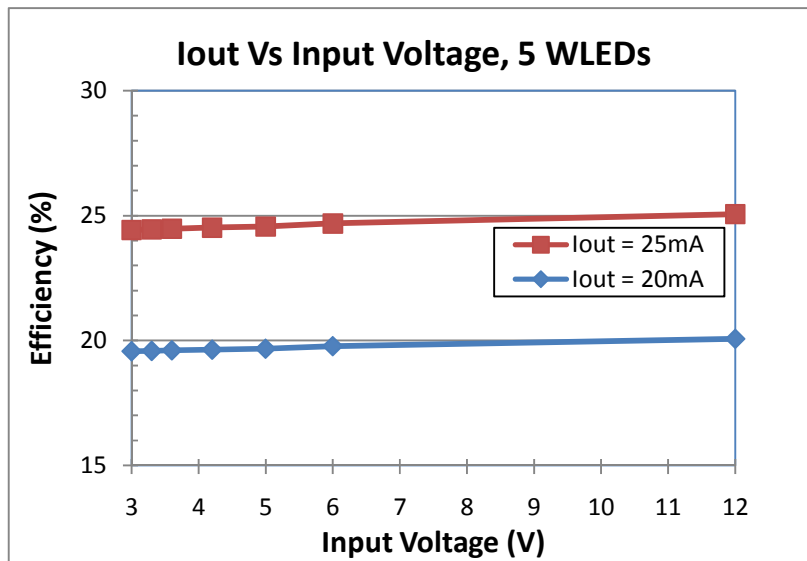

Figure 3. L1 = 22uH Output Current Vs Input Voltage for 5 WLEDs at 20mA & 25mA

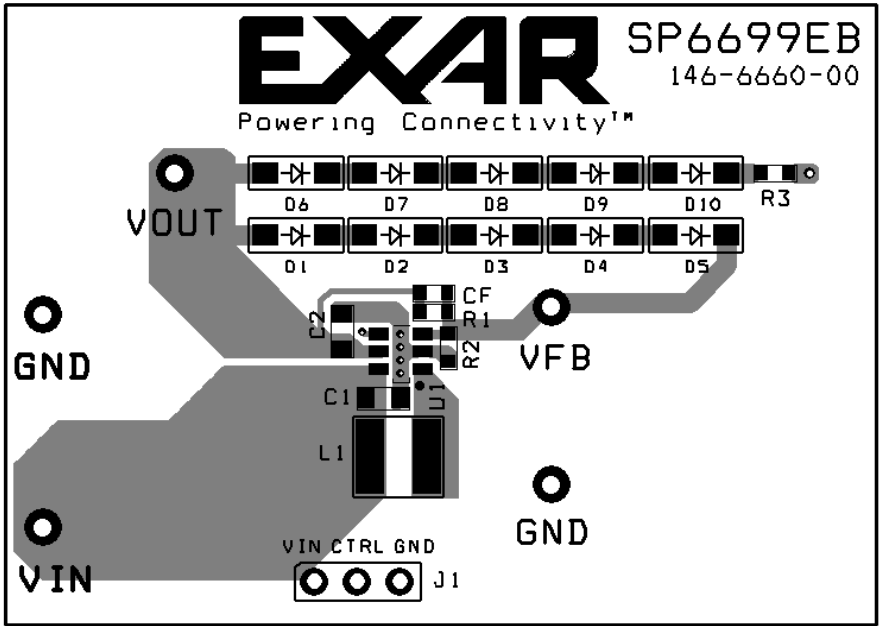

Figure 4. SP6699 Evaluation Board Layout top

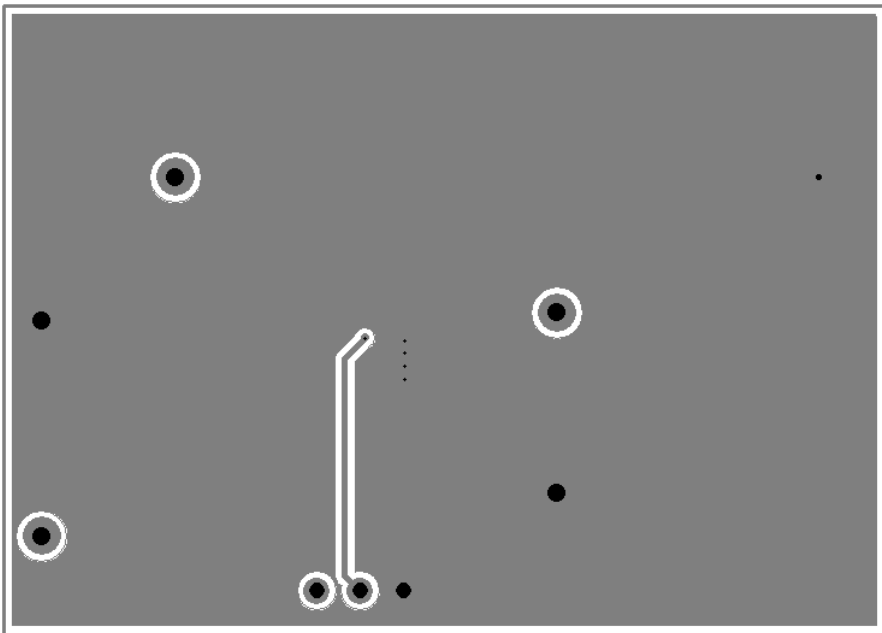

Figure 5. SP6699 Evaluation Board Layout bottom

Part Ref.	Qty.	Part Number	Part Description	Layout Size	Manufacturer
U1	1	SP6699ER-L	Boost LED driver	SOT23-6	www.exar.com
PCB	1	146-6660-00	Eval bd PCB		www.exar.com
C1,C2	2	GRM216R61E105K	1μF/25V, X5R SM capacitor	0805, 0.9mm ht.	
CF,R1,R3,D6,D7,D8,D9,D10	8	Not Populated			
L1	1	LQH32CN220K53	22μH,250mA,0.71Ω DCR,10%		www.murata.com
R2	1	CRCW060310R0F	10Ω, 1% SM resistor	0603	www.vishay.com
D1,D2,D3,D4,D5	5	any	SM WLED	1206	any
J1	1	61303611121	3 pin header	6x2.54mm pitch	www.we-online.com
	1	60900213421	Shunt	5x2.54mm pitch	www.we-online.com
Vin,Vout GND,VFB	4	0300-1-15-01-47-01-10-0	Test Point female pin	0.042" dia	Mil-Max Mfg. Corp. www.digikey.com

Table1. SP6699EB List of Materials

ORDERING INFORMATION

Model	Temperature Range	Package Type
SP6699EB.....	-40°C to +85°C.....	SP6699 Evaluation Board
SP6699ER-L.....	-40°C to +85°C.....	Lead Free 6 pin SOT23-6

For further assistance:

Email: customersupport@exar.com
 EXAR Technical Documentation: <http://www.exar.com/TechDoc/default.aspx?>



Exar Corporation
Headquarters and
Sales Office
 48720 Kato Road
 Fremont, CA 94538
 main: 510-668-7000
 fax: 510-668-7000

Exar Corporation reserves the right to make changes to any products described herein. Exar does not assume any liability arising out of the application or use of any product or circuit described herein; neither does it convey any license under its patent rights nor the rights of others.



Компания «ЭлектроПласт» предлагает заключение долгосрочных отношений при поставках импортных электронных компонентов на взаимовыгодных условиях!

Наши преимущества:

- Оперативные поставки широкого спектра электронных компонентов отечественного и импортного производства напрямую от производителей и с крупнейших мировых складов;
- Поставка более 17-ти миллионов наименований электронных компонентов;
- Поставка сложных, дефицитных, либо снятых с производства позиций;
- Оперативные сроки поставки под заказ (от 5 рабочих дней);
- Экспресс доставка в любую точку России;
- Техническая поддержка проекта, помощь в подборе аналогов, поставка прототипов;
- Система менеджмента качества сертифицирована по Международному стандарту ISO 9001;
- Лицензия ФСБ на осуществление работ с использованием сведений, составляющих государственную тайну;
- Поставка специализированных компонентов (Xilinx, Altera, Analog Devices, Intersil, Interpoint, Microsemi, Aeroflex, Peregrine, Syfer, Eurofarad, Texas Instrument, Miteq, Cobham, E2V, MA-COM, Hittite, Mini-Circuits, General Dynamics и др.);

Помимо этого, одним из направлений компании «ЭлектроПласт» является направление «Источники питания». Мы предлагаем Вам помощь Конструкторского отдела:

- Подбор оптимального решения, техническое обоснование при выборе компонента;
- Подбор аналогов;
- Консультации по применению компонента;
- Поставка образцов и прототипов;
- Техническая поддержка проекта;
- Защита от снятия компонента с производства.



Как с нами связаться

Телефон: 8 (812) 309 58 32 (многоканальный)

Факс: 8 (812) 320-02-42

Электронная почта: org@eplast1.ru

Адрес: 198099, г. Санкт-Петербург, ул. Калинина, дом 2, корпус 4, литера А.