

Quad 2-input Schmitt NAND gate

Datasheet - production data

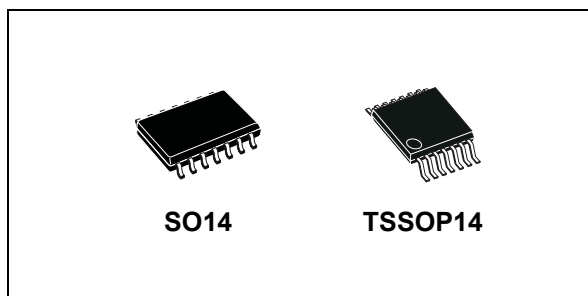

- Wide operating voltage range:
 $V_{CC} \text{ (opr)} = 2 \text{ V to } 6 \text{ V}$
- Pin and function compatible with 74 series 132
- ESD performance
 - HBM: 2 kV
 - MM: 200 V
 - CDM: 1 kV

Description

The M74HC132 is a high-speed CMOS quad 2-input Schmitt NAND gate fabricated with silicon gate C²MOS technology.

Pin configuration and function are identical to those of the M74HC00. The hysteresis characteristics (around 20 % V_{CC}) of all inputs allow slowly changing input signals to be transformed into sharply defined jitter-free output signals.

All inputs are equipped with protection circuits against static discharge and transient excess voltage.

Features

- High-speed:
 $t_{PD} = 11 \text{ ns (typ.) at } V_{CC} = 6 \text{ V}$
- Low power dissipation:
 $I_{CC} = 1 \mu\text{A (max.) at } T_A = 25 \text{ }^\circ\text{C}$
- High noise immunity:
 $V_H(\text{typ}) = 0.9 \text{ V at } V_{CC} = 5 \text{ V}$
- Symmetrical output impedance:
 $I_{OH} = I_{OL} = 4 \text{ mA (min.)}$
- Balanced propagation delays:
 $t_{PLH} \cong t_{PHL}$

Table 1. Device summary

Order code	Temp. range	Package	Packing	Marking
M74HC132RM13TR	-55 °C to 125 °C	S014	Tape and reel	74HC132
M74HC132YRM13TR ⁽¹⁾	-40 °C to 125 °C	SO14 (automotive grade)		74HC132Y
M74HC132TTR	-55 °C to 125 °C	TSSOP14		HC132
M74HC132YTTR ⁽¹⁾	-40 °C to 125 °C	TSSOP14 (automotive grade)		HC132Y

1. Qualification and characterization according to AEC Q100 and Q003 or equivalent, advanced screening according to AEC Q001 and Q002 or equivalent.

Contents

1	Pin information	3
2	Functional description	4
3	Electrical characteristics	5
4	Package information	9
	4.1 SO14 package information	10
	4.2 TSSOP14 package information	11
5	Ordering information	12
6	Revision history	12

1 Pin information

Figure 1. Pin connection and IED logic symbols

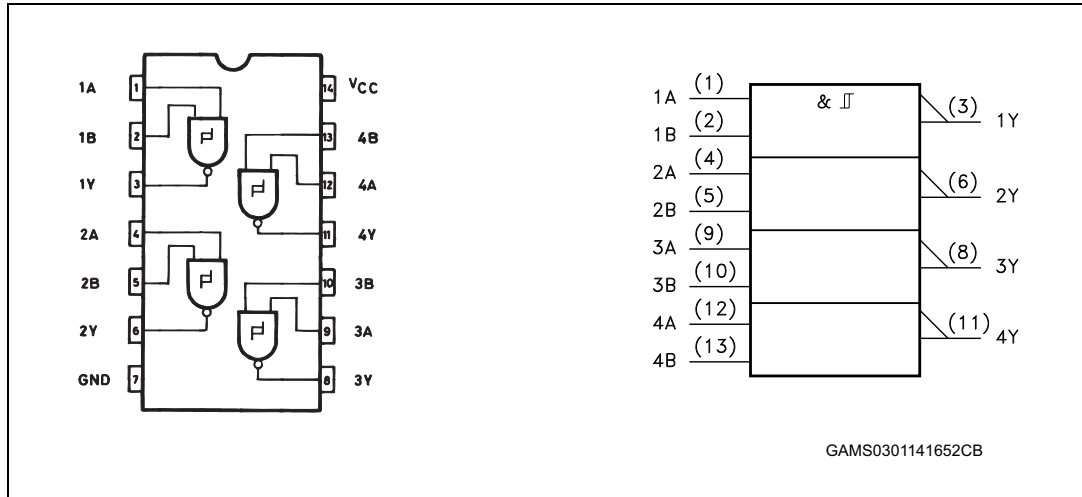

Table 2. Pin description

Pin no	Symbol	Name and function
1, 4, 9, 12	1A to 4A	Data inputs
2, 5, 10, 13	1B to 4B	
3, 6, 8, 11	1Y to 4Y	Data outputs
7	GND	Ground (0 V)
14	V _{CC}	Positive supply voltage

2 Functional description

Table 3. Truth table

A	B	Y
L	L	H
L	H	H
H	L	H
H	H	L

Figure 2. Input and output equivalent circuit

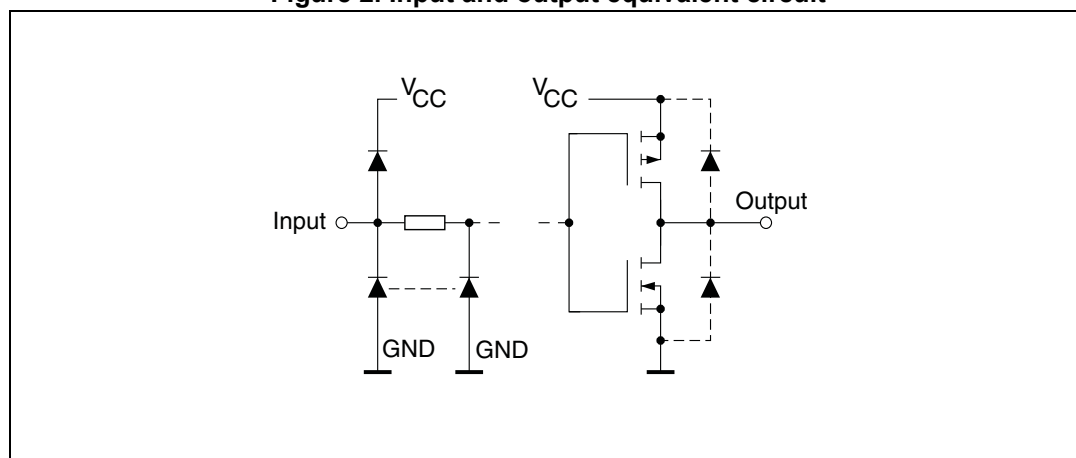

3 Electrical characteristics

“Absolute maximum ratings” are those values beyond which damage to the device may occur. Functional operation under these conditions is not implied.

Table 4. Absolute maximum ratings

Symbol	Parameter		Value	Unit
V_{CC}	Supply voltage		-0.5 to +7	V
V_I	DC input voltage		-0.5 to $V_{CC} + 0.5$	
V_O	DC output voltage			
I_{IK}	DC input diode current		± 20	mA
I_{OK}	DC output diode current			
I_O	DC output current		± 25	
I_{CC} or I_{GND}	DC V_{CC} or ground current		± 50	
P_D	Power dissipation	SO14	500 ⁽¹⁾	mW
		TSSOP14	450 ⁽¹⁾	
T_{stg}	Storage temperature		-65 to +150	°C
T_L	Lead temperature (10 sec)		300	

1. Power dissipation at 65 °C. Derating from 65 °C to 125 °C: SO14 -7 mW/°C, TSSOP14 -6.1 mW/°C.

Table 5. Recommended operating conditions

Symbol	Parameter		Value	Unit
V_{CC}	Supply voltage		2 to 6	V
V_I	Input voltage		0 to V_{CC}	
V_O	Output voltage			
T_{op}	Operating temperature		-55 to 125	°C

Table 6. DC specifications

Symbol	Parameter	Test condition		Value						Unit	
		V _{CC} (V)		T _A = 25 °C			-40 to 85 °C		-55 to 125 °C		
				Min.	Typ.	Max.	Min.	Max.	Min.		Max.
V _P	High level threshold voltage	2.0		1.0	1.25	1.5	1.0	1.5	1.0	1.5	V
		4.5		2.3	2.7	3.15	2.3	3.15	2.3	3.15	
		6.0		3.0	3.5	4.2	3.0	4.2	3.0	4.2	
V _N	Low level threshold voltage	2.0		0.3	0.65	0.9	0.3	0.9	0.3	0.9	V
		4.5		1.13	1.6	2.0	1.13	2.0	1.13	2.0	
		6.0		1.5	2.3	2.6	1.5	2.6	1.5	2.6	
V _H	Hysteresis voltage	2.0		0.3	0.6	1.0	0.3	1.0	0.3	1.0	V
		4.5		0.6	1.1	1.4	0.6	1.4	0.6	1.4	
		6.0		0.8	1.2	1.4	0.8	1.7	0.8	1.7	
V _{OH}	High level output voltage	2.0	I _O = -20 μA	1.9	2.0		1.9		1.9		V
		4.5	I _O = -20 μA	4.4	4.5		4.4		4.4		
		6.0	I _O = -20 μA	5.9	6.0		5.9		5.9		
		4.5	I _O = -4.0 mA	4.18	4.31		4.13		4.10		
		6.0	I _O = -5.2 mA	5.68	5.8		5.63		5.60		
V _{OL}	Low level output voltage	2.0	I _O = -20 μA			0.1		0.1		0.1	V
		4.5	I _O = -20 μA			0.1		0.1		0.1	
		6.0	I _O = -20 μA			0.1		0.1		0.1	
		4.5	I _O = -4.0 mA		0.17	0.26		0.33		0.40	
		6.0	I _O = -5.2 mA		0.18	0.26		0.33		0.40	
I _I	Input leakage current	6.0	V _I = V _{CC} or GND			±0.1		±1		±1	μA
I _{CC}	Quiescent supply current	6.0	V _I = V _{CC} or GND			1		10		20	μA

Table 7. AC electrical characteristics
($C_L = 50 \text{ pF}$, Input $t_r = t_f = 6 \text{ ns}$)

Symbol	Parameter	Test condition	Value						Unit		
			V_{CC} (V)	$T_A = 25 \text{ }^\circ\text{C}$			$-40 \text{ to } 85 \text{ }^\circ\text{C}$			$-55 \text{ to } 125 \text{ }^\circ\text{C}$	
				Min.	Typ.	Max.	Min.	Max.		Min.	Max.
t_{TLH}, t_{THL}	Output transition time	2.0	-	30	75	-	95	-	110	ns	
		4.5	-	8	15	-	19	-	22		
		6.0	-	7	13	-	16	-	19		
t_{PLH}, t_{PHL}	Propagation delay time	2.0	-	52	105	-	130	-	160	ns	
		4.5	-	13	21	-	26	-	32		
		6.0	-	11	18	-	22	-	27		

Table 8. Capacitive characteristics

Sym	Parameter	Test condition	Value						Unit		
			V_{CC} (V)	$T_A = 25 \text{ }^\circ\text{C}$			$-40 \text{ to } 85 \text{ }^\circ\text{C}$			$-55 \text{ to } 125 \text{ }^\circ\text{C}$	
				Min	Typ	Max	Min	Max		Min	Max
C_{IN}	Input capacitance	5.0	-	5	10	-	10	-	10	pF	
C_{PD}	Power dissipation capacitance ⁽¹⁾		-	29	-	-	-	-			

1. C_{PD} is defined as the value of the IC's internal equivalent capacitance which is calculated from the operating current consumption without load (refer to test circuit). Average operating current can be obtained by the following equation:
 $I_{CC(opr)} = C_{PD} \times V_{CC} \times f_{IN} + I_{CC}/4$ (per gate).

Figure 3. Test circuit

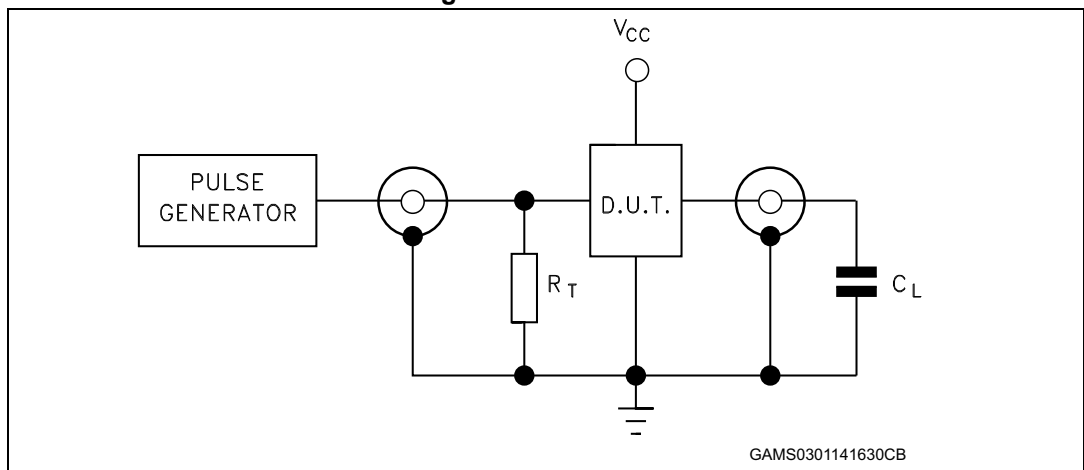

1. Legend:
 $C_L = 50 \text{ pF}$ or equivalent (includes jig and probe capacitance).
 $R_T = Z_{OUT}$ of pulse generator (typically $50 \text{ } \Omega$).

Figure 4. Propagation delay times
(f = 1 MHz; 50 % duty cycle)

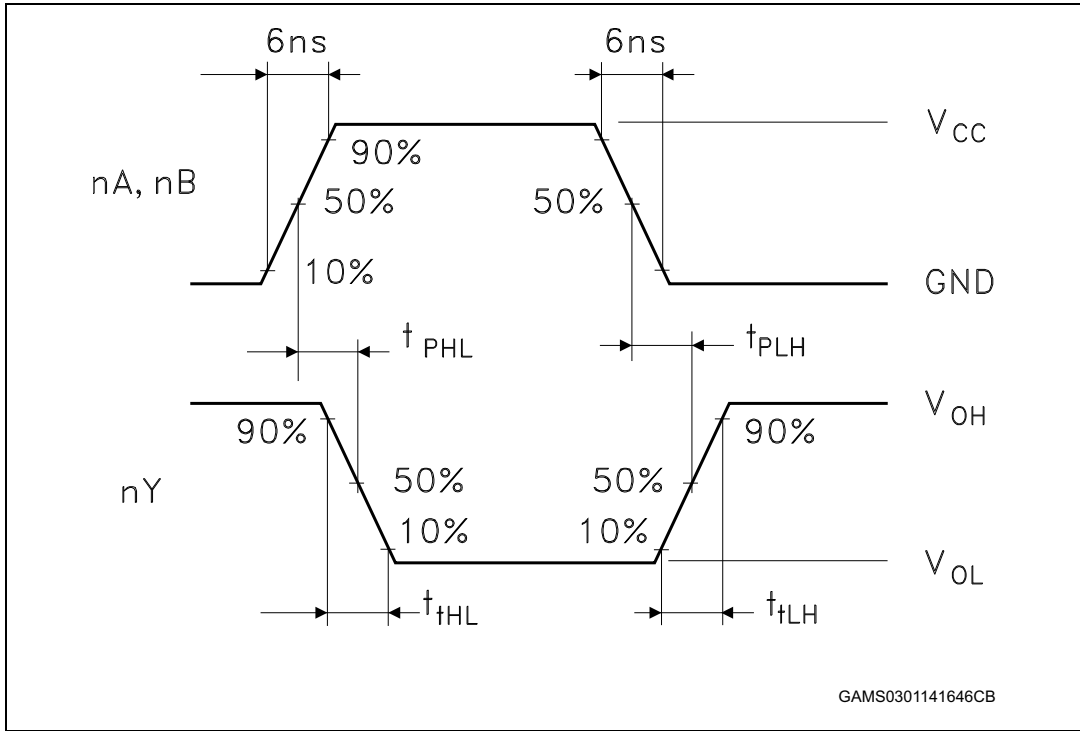

4 Package information

In order to meet environmental requirements, ST offers these devices in different grades of ECOPACK[®] packages, depending on their level of environmental compliance. ECOPACK[®] specifications, grade definitions and product status are available at: www.st.com. ECOPACK[®] is an ST trademark.

4.1 SO14 package information

Figure 5. SO14 package mechanical drawing

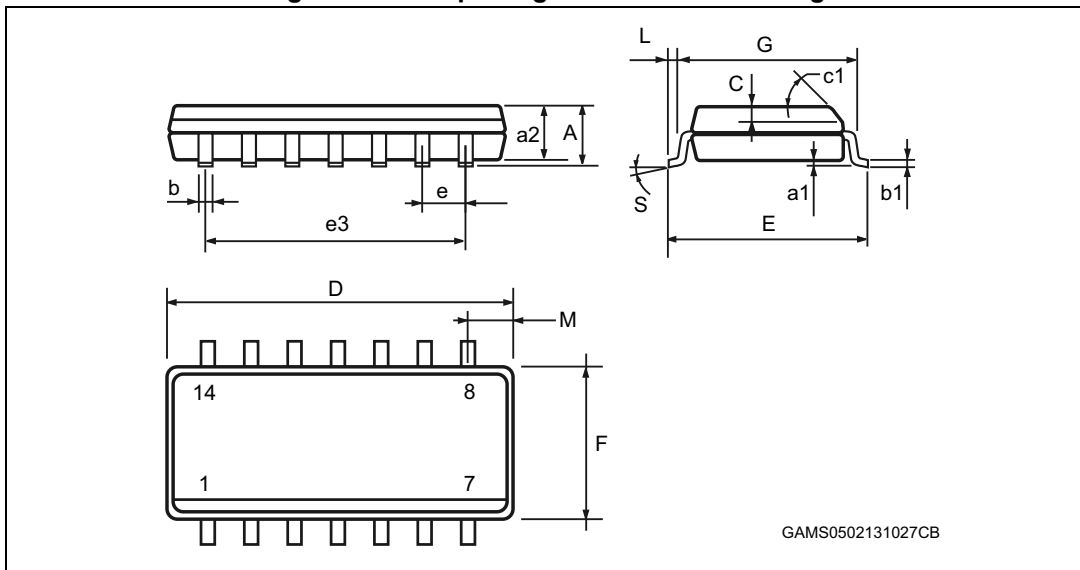

Table 9. SO14 package mechanical data

Ref	Dimensions					
	Millimeters			Inches		
	Min.	Typ.	Max.	Min.	Typ.	Max.
A			1.75			0.068
a1	0.1		0.2	0.003		0.007
a2			1.65			0.064
b	0.35		0.46	0.013		0.018
b1	0.19		0.25	0.007		0.010
C		0.5			0.019	
c1		45 °			45 °	
D	8.55		8.75	0.336		0.344
E	5.8		6.2	0.228		0.244
e		1.27			0.050	
e3		7.62			0.300	
F	3.8		4.0	0.149		0.157
G	4.6		5.3	0.181		0.208
L	0.5		1.27	0.019		0.050
M			0.68			0.026
S			8 °			8 °

4.2 TSSOP14 package information

Figure 6. TSSOP14 package mechanical drawing

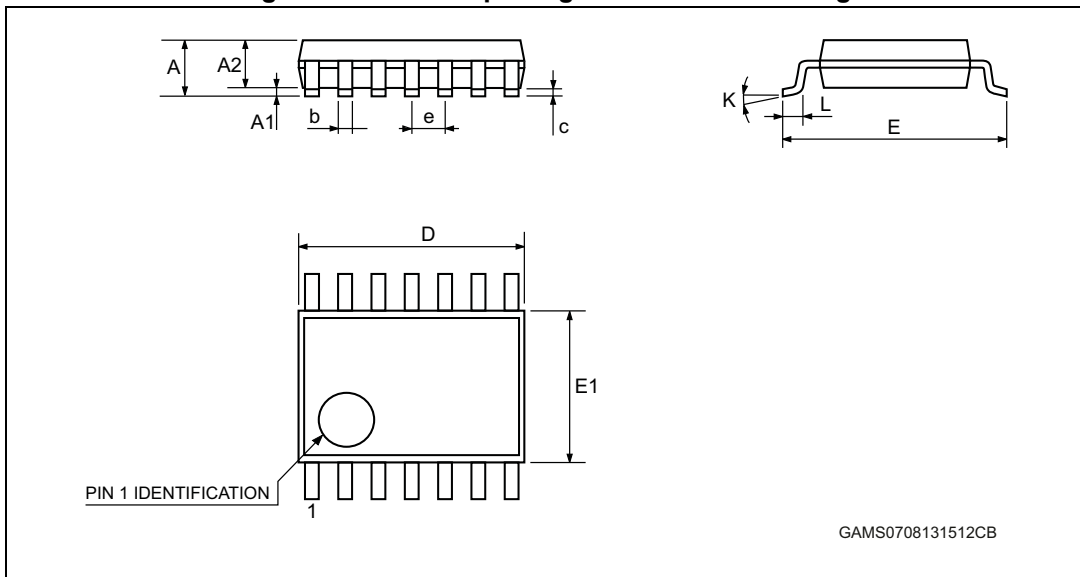

Table 10. TSSOP14 package mechanical data

Ref	Dimensions					
	Millimeters			Inches		
	Min.	Typ.	Max.	Min.	Typ.	Max.
A			1.2			0.047
A1	0.05		0.15	0.002	0.004	0.006
A2	0.8	1	1.05	0.031	0.039	0.041
b	0.19		0.30	0.007		0.012
c	0.09		0.20	0.004		0.0089
D	4.9	5	5.1	0.193	0.197	0.201
E	6.2	6.4	6.6	0.244	0.252	0.260
E1	4.3	4.4	4.48	0.169	0.173	0.176
e		0.65			0.0256	
K	0 °		8 °	0 °		8 °
L	0.45	0.60	0.75	0.018	0.024	0.030

5 Ordering information

Table 11. Order codes

Order code	Temp. range	Package	Packing	Marking
M74HC132RM13TR	-55 °C to 125 °C	S014	Tape and reel	74HC132
M74HC132YRM13TR ⁽¹⁾	-40 °C to 125 °C	SO14 (automotive grade)		74HC132Y
M74HC132TTR	-55 °C to 125 °C	TSSOP14		HC132
M74HC132YTTR ⁽¹⁾	-40 °C to 125 °C	TSSOP14 (automotive grade)		HC132Y

1. Qualification and characterization according to AEC Q100 and Q003 or equivalent, advanced screening according to AEC Q001 and Q002 or equivalent.

6 Revision history

Table 12. Document revision history

Date	Revision	Changes
10-Jan-2014	3	Removed DIP14 package Added ESD data to Features Table 1: Device summary : added automotive grade order codes, added temperature range and marking details. Added Section 5: Ordering information .

Please Read Carefully:

Information in this document is provided solely in connection with ST products. STMicroelectronics NV and its subsidiaries ("ST") reserve the right to make changes, corrections, modifications or improvements, to this document, and the products and services described herein at any time, without notice.

All ST products are sold pursuant to ST's terms and conditions of sale.

Purchasers are solely responsible for the choice, selection and use of the ST products and services described herein, and ST assumes no liability whatsoever relating to the choice, selection or use of the ST products and services described herein.

No license, express or implied, by estoppel or otherwise, to any intellectual property rights is granted under this document. If any part of this document refers to any third party products or services it shall not be deemed a license grant by ST for the use of such third party products or services, or any intellectual property contained therein or considered as a warranty covering the use in any manner whatsoever of such third party products or services or any intellectual property contained therein.

UNLESS OTHERWISE SET FORTH IN ST'S TERMS AND CONDITIONS OF SALE ST DISCLAIMS ANY EXPRESS OR IMPLIED WARRANTY WITH RESPECT TO THE USE AND/OR SALE OF ST PRODUCTS INCLUDING WITHOUT LIMITATION IMPLIED WARRANTIES OF MERCHANTABILITY, FITNESS FOR A PARTICULAR PURPOSE (AND THEIR EQUIVALENTS UNDER THE LAWS OF ANY JURISDICTION), OR INFRINGEMENT OF ANY PATENT, COPYRIGHT OR OTHER INTELLECTUAL PROPERTY RIGHT.

ST PRODUCTS ARE NOT DESIGNED OR AUTHORIZED FOR USE IN: (A) SAFETY CRITICAL APPLICATIONS SUCH AS LIFE SUPPORTING, ACTIVE IMPLANTED DEVICES OR SYSTEMS WITH PRODUCT FUNCTIONAL SAFETY REQUIREMENTS; (B) AERONAUTIC APPLICATIONS; (C) AUTOMOTIVE APPLICATIONS OR ENVIRONMENTS, AND/OR (D) AEROSPACE APPLICATIONS OR ENVIRONMENTS. WHERE ST PRODUCTS ARE NOT DESIGNED FOR SUCH USE, THE PURCHASER SHALL USE PRODUCTS AT PURCHASER'S SOLE RISK, EVEN IF ST HAS BEEN INFORMED IN WRITING OF SUCH USAGE, UNLESS A PRODUCT IS EXPRESSLY DESIGNATED BY ST AS BEING INTENDED FOR "AUTOMOTIVE, AUTOMOTIVE SAFETY OR MEDICAL" INDUSTRY DOMAINS ACCORDING TO ST PRODUCT DESIGN SPECIFICATIONS. PRODUCTS FORMALLY ESCC, QML OR JAN QUALIFIED ARE DEEMED SUITABLE FOR USE IN AEROSPACE BY THE CORRESPONDING GOVERNMENTAL AGENCY.

Resale of ST products with provisions different from the statements and/or technical features set forth in this document shall immediately void any warranty granted by ST for the ST product or service described herein and shall not create or extend in any manner whatsoever, any liability of ST.

ST and the ST logo are trademarks or registered trademarks of ST in various countries.

Information in this document supersedes and replaces all information previously supplied.

The ST logo is a registered trademark of STMicroelectronics. All other names are the property of their respective owners.

© 2014 STMicroelectronics - All rights reserved

STMicroelectronics group of companies

Australia - Belgium - Brazil - Canada - China - Czech Republic - Finland - France - Germany - Hong Kong - India - Israel - Italy - Japan - Malaysia - Malta - Morocco - Philippines - Singapore - Spain - Sweden - Switzerland - United Kingdom - United States of America

www.st.com





Компания «ЭлектроПласт» предлагает заключение долгосрочных отношений при поставках импортных электронных компонентов на взаимовыгодных условиях!

Наши преимущества:

- Оперативные поставки широкого спектра электронных компонентов отечественного и импортного производства напрямую от производителей и с крупнейших мировых складов;
- Поставка более 17-ти миллионов наименований электронных компонентов;
- Поставка сложных, дефицитных, либо снятых с производства позиций;
- Оперативные сроки поставки под заказ (от 5 рабочих дней);
- Экспресс доставка в любую точку России;
- Техническая поддержка проекта, помощь в подборе аналогов, поставка прототипов;
- Система менеджмента качества сертифицирована по Международному стандарту ISO 9001;
- Лицензия ФСБ на осуществление работ с использованием сведений, составляющих государственную тайну;
- Поставка специализированных компонентов (Xilinx, Altera, Analog Devices, Intersil, Interpoint, Microsemi, Aeroflex, Peregrine, Syfer, Eurofarad, Texas Instrument, Miteq, Cobham, E2V, MA-COM, Hittite, Mini-Circuits, General Dynamics и др.);

Помимо этого, одним из направлений компании «ЭлектроПласт» является направление «Источники питания». Мы предлагаем Вам помощь Конструкторского отдела:

- Подбор оптимального решения, техническое обоснование при выборе компонента;
- Подбор аналогов;
- Консультации по применению компонента;
- Поставка образцов и прототипов;
- Техническая поддержка проекта;
- Защита от снятия компонента с производства.



Как с нами связаться

Телефон: 8 (812) 309 58 32 (многоканальный)

Факс: 8 (812) 320-02-42

Электронная почта: org@eplast1.ru

Адрес: 198099, г. Санкт-Петербург, ул. Калинина, дом 2, корпус 4, литера А.