



# STM1001

---

## Reset circuit

---

### Features

- Precision monitoring of 3 V, 3.3 V, and 5 V supply voltages
- Open drain  $\overline{\text{RST}}$  output
- 30 ms or 140 ms reset pulse width (min)
- Low supply current - 6  $\mu\text{A}$  (typ)
- Guaranteed  $\overline{\text{RST}}$  assertion down to  $V_{\text{CC}} = 1.0 \text{ V}$
- Operating temperature:
  - $-40 \text{ }^\circ\text{C}$  to  $85 \text{ }^\circ\text{C}$  (industrial grade)
- Lead-free, small SOT23 package

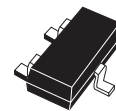

SOT23-3 (WX)

# Contents

<b>1</b>	<b>Description</b> .....	<b>5</b>
<b>2</b>	<b>Operation</b> .....	<b>7</b>
	2.1 Reset output .....	7
	2.2 Negative-going $V_{CC}$ transients .....	7
<b>3</b>	<b>Typical operating characteristics</b> .....	<b>8</b>
<b>4</b>	<b>Maximum ratings</b> .....	<b>11</b>
<b>5</b>	<b>DC and AC parameters</b> .....	<b>12</b>
<b>6</b>	<b>Package mechanical data</b> .....	<b>14</b>
<b>7</b>	<b>Part numbering</b> .....	<b>15</b>
<b>8</b>	<b>Revision history</b> .....	<b>17</b>

## List of tables

Table 1.	Signal names . . . . .	5
Table 2.	Absolute maximum ratings . . . . .	11
Table 3.	Operating and AC measurement conditions . . . . .	12
Table 4.	DC and AC characteristics . . . . .	13
Table 5.	SOT23-3 – 3-lead small outline transistor package mechanical data. . . . .	14
Table 6.	Ordering information scheme . . . . .	15
Table 7.	Marking description. . . . .	16
Table 8.	Document revision history . . . . .	17

## List of figures

Figure 1.	Logic diagram . . . . .	5
Figure 2.	Connections . . . . .	5
Figure 3.	Block diagram . . . . .	6
Figure 4.	Hardware hookup . . . . .	6
Figure 5.	Supply current vs. temperature, L/M/R/S/T (no load) . . . . .	8
Figure 6.	Power-down reset delay vs. temperature - $V_{OD} = V_{TH} - V_{CC}$ (L/M) . . . . .	8
Figure 7.	Power-down reset delay vs. temperature - $V_{OD} = V_{TH} - V_{CC}$ (R/S/T) . . . . .	9
Figure 8.	Power-up $t_{rec}$ vs. temperature . . . . .	9
Figure 9.	Normalized reset threshold vs. temperature. . . . .	10
Figure 10.	Max transient duration not causing reset pulse vs. reset comparator overdrive. . . . .	10
Figure 11.	AC testing input/output waveforms . . . . .	12
Figure 12.	SOT23-3 – 3-lead small outline transistor package outline . . . . .	14

# 1 Description

The STM1001 microprocessor reset circuit is a low-power supervisory device used to monitor power supplies. It performs a single function: asserting a reset signal whenever the  $V_{CC}$  supply voltage drops below a preset value and keeping it asserted until  $V_{CC}$  has risen above the preset threshold for a minimum period of time ( $t_{rec}$ ).

**Figure 1. Logic diagram**

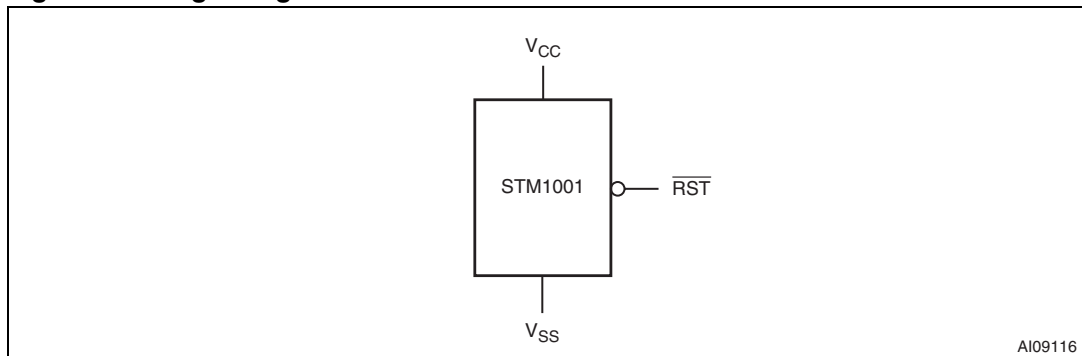

AI09116

**Table 1. Signal names**

$V_{SS}$	Ground
RST	Active-low reset output (open drain)
$V_{CC}$	Supply voltage

**Figure 2. Connections**

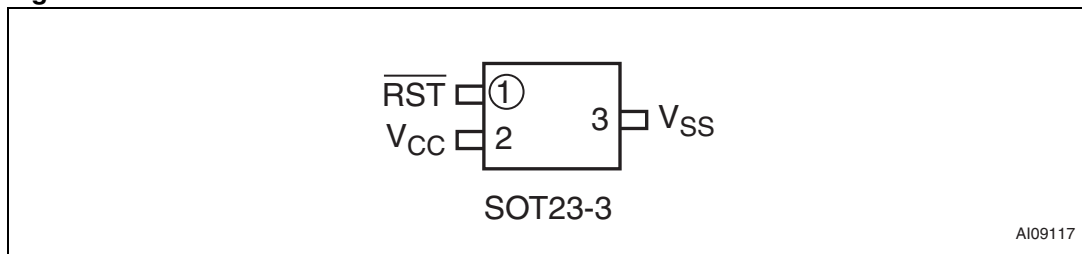

AI09117

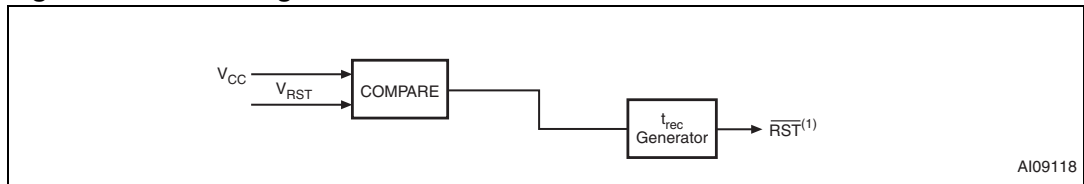
**Figure 3. Block diagram**

1. Open drain

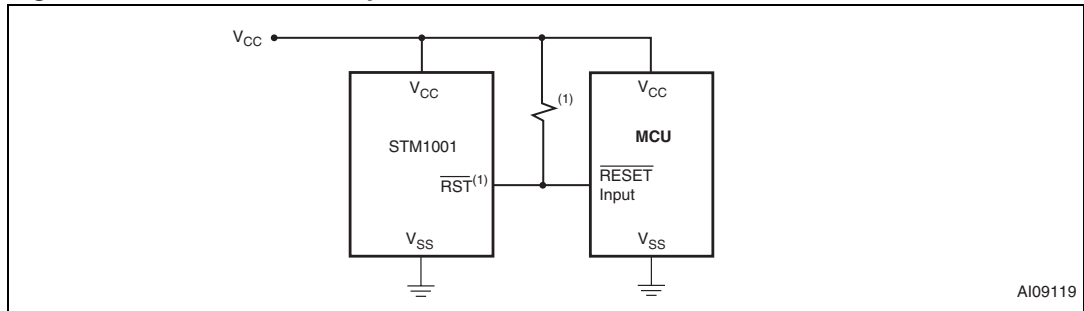
**Figure 4. Hardware hookup**

1.  $\overline{RST}^{(1)}$  output requires pull-up resistor.

## 2 Operation

### 2.1 Reset output

The STM1001 microprocessor reset circuit asserts a reset signal to the MCU whenever  $V_{CC}$  goes below the reset threshold ( $V_{RST}$ ).  $\overline{RST}$  is guaranteed valid down to  $V_{CC} = 1\text{ V}$  ( $0^\circ$  to  $70^\circ\text{C}$ ).

During power-up, once  $V_{CC}$  exceeds the reset threshold an internal timer keeps  $\overline{RST}$  low for the reset time-out period,  $t_{rec}$ . After this interval,  $\overline{RST}$  returns high.

If  $V_{CC}$  drops below the reset threshold,  $\overline{RST}$  goes low. Each time  $\overline{RST}$  is asserted, it stays low for at least the reset time-out period. Any time  $V_{CC}$  goes below the reset threshold, the internal timer clears. The reset timer starts when  $V_{CC}$  returns above the reset threshold. The active-low reset ( $\overline{RST}$ ) is an open drain output.

### 2.2 Negative-going $V_{CC}$ transients

The STM1001 is relatively immune to negative-going  $V_{CC}$  transients (glitches). [Figure 10 on page 10](#) shows typical transient duration versus reset comparator overdrive (for which the STM1001 will NOT generate a reset pulse). The graph was generated using a negative pulse applied to  $V_{CC}$ , starting at 0.5 V above the actual reset threshold and ending below it by the magnitude indicated (comparator overdrive). The graph indicates the maximum pulse width a negative  $V_{CC}$  transient can have without causing a reset pulse. As the magnitude of the transient increases (further below the threshold), the maximum allowable pulse width decreases. Any combination of duration and overdrive which lies under the curve will NOT generate a reset signal. Typically, a  $V_{CC}$  transient that goes 100 mV below the reset threshold and lasts 20  $\mu\text{s}$  or less will not cause a reset pulse. A 0.1  $\mu\text{F}$  bypass capacitor mounted as close as possible to the  $V_{CC}$  pin provides additional transient immunity.

### 3 Typical operating characteristics

Note: Typical values are at  $T_A = 25\text{ }^\circ\text{C}$ ,  $V_{CC} = 5\text{ V}$  for L/M versions,  $V_{CC} = 3.3\text{ V}$  for T/S versions, and  $V_{CC} = 3.0\text{ V}$  for R versions.

Figure 5. Supply current vs. temperature, L/M/R/S/T (no load)

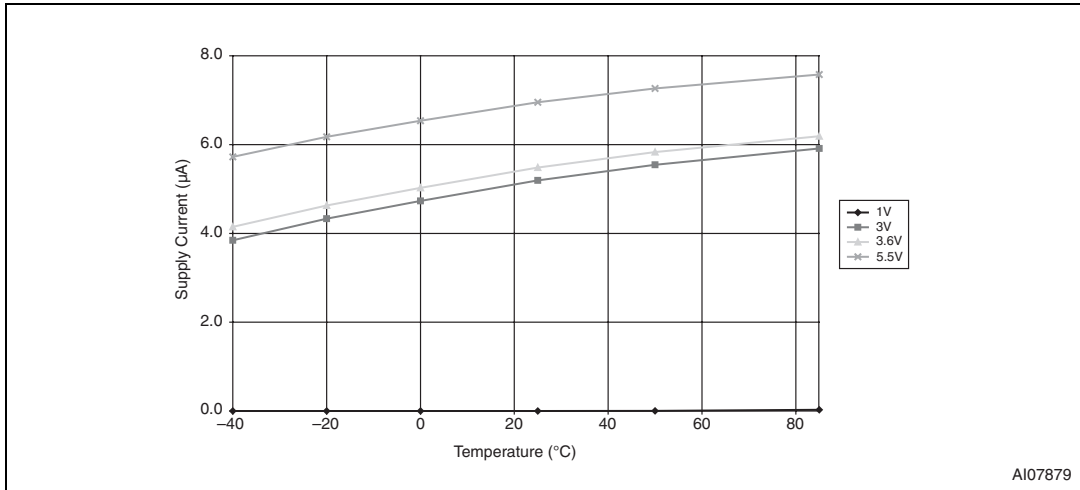

Figure 6. Power-down reset delay vs. temperature -  $V_{OD} = V_{TH} - V_{CC}$  (L/M)

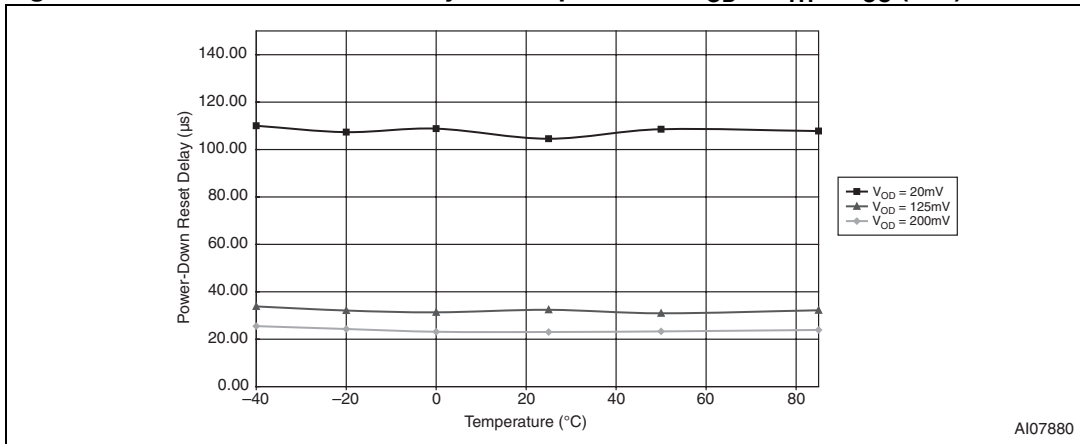
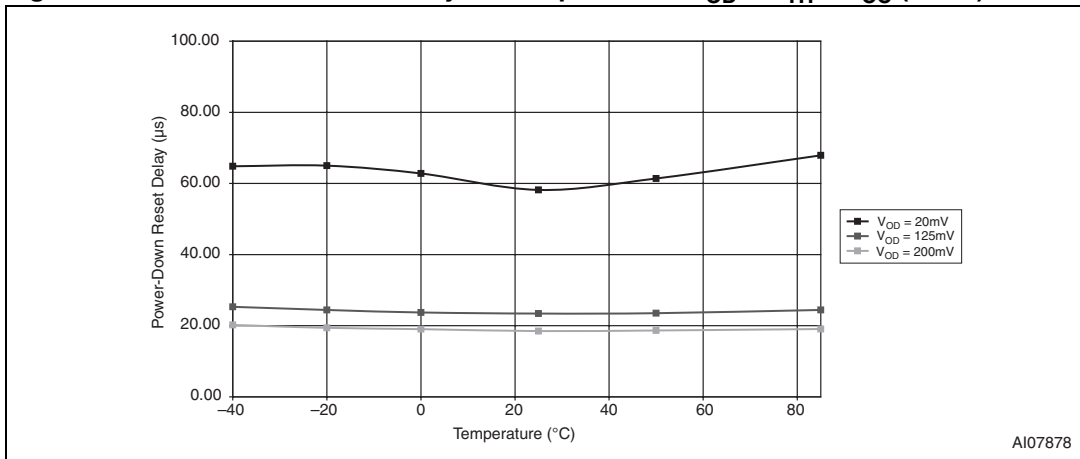

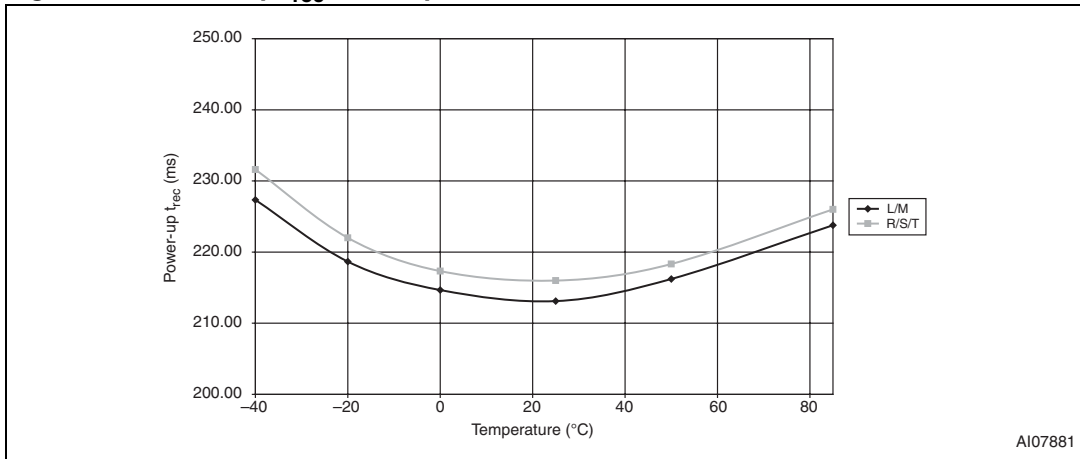

Figure 7. Power-down reset delay vs. temperature -  $V_{OD} = V_{TH} - V_{CC}$  (R/S/T)



AI07878

Figure 8. Power-up  $t_{rec}$  vs. temperature



AI07881

Note: Valid for  $t_{rec} = 210\text{ ms}$  (typ).

**Figure 9. Normalized reset threshold vs. temperature**

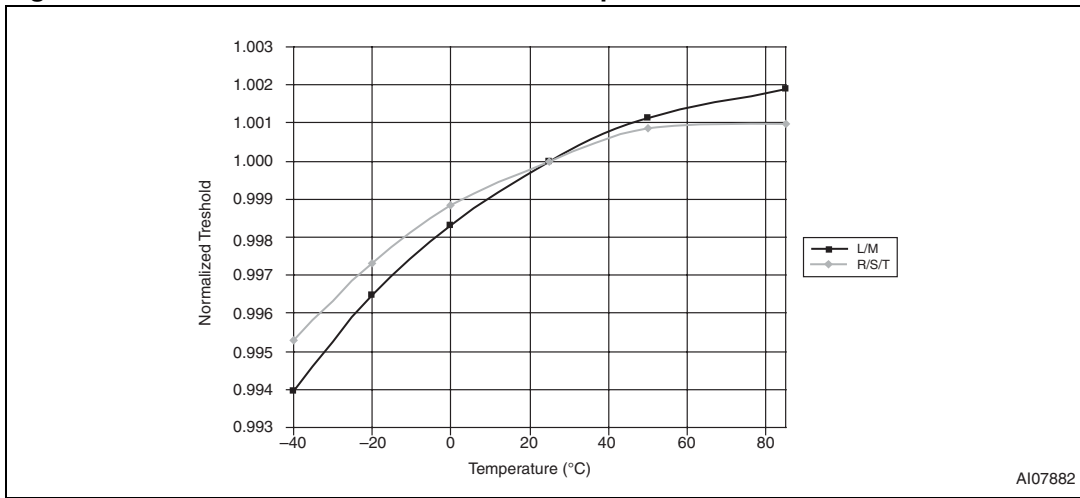

**Figure 10. Max transient duration not causing reset pulse vs. reset comparator overdrive**

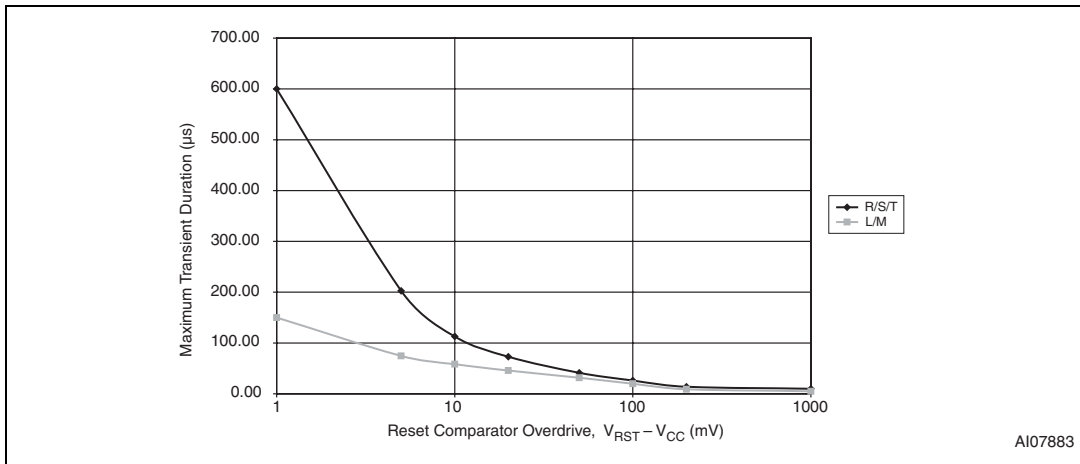

## 4 Maximum ratings

Stressing the device above the rating listed in the absolute maximum ratings table may cause permanent damage to the device. These are stress ratings only and operation of the device at these or any other conditions above those indicated in the operating sections of this specification is not implied. Exposure to absolute maximum rating conditions for extended periods may affect device reliability. Refer also to the STMicroelectronics SURE Program and other relevant quality documents.

**Table 2. Absolute maximum ratings**

Symbol	Parameter	Value	Unit
$T_{STG}$	Storage temperature ( $V_{CC}$ off)	-55 to 150	°C
$T_{SLD}^{(1)}$	Lead solder temperature for 10 seconds	260	°C
$V_{IO}$	Input or output voltage	-0.3 to $V_{CC} + 0.3$	V
$V_{CC}$	Supply voltage	-0.3 to 7.0	V
$I_O$	Output current	20	mA
$P_D$	Power dissipation	320	mW

1. Reflow at peak temperature of 260 °C. The time above 255 °C must not exceed 30 seconds.

## 5 DC and AC parameters

This section summarizes the operating measurement conditions, and the DC and AC characteristics of the device. The parameters in the DC and AC characteristics tables that follow, are derived from tests performed under the measurement conditions summarized in [Table 3: Operating and AC measurement conditions](#). Designers should check that the operating conditions in their circuit match the operating conditions when relying on the quoted parameters.

**Table 3. Operating and AC measurement conditions**

Parameter	STM1001	Unit
V <sub>CC</sub> supply voltage	1.0 to 5.5	V
Ambient operating temperature (T <sub>A</sub> )	-40 to 85	°C
Input rise and fall times	≤ 5	ns
Input pulse voltages	0.2 to 0.8 V <sub>CC</sub>	V
Input and output timing ref. voltages	0.3 to 0.7 V <sub>CC</sub>	V

**Figure 11. AC testing input/output waveforms**

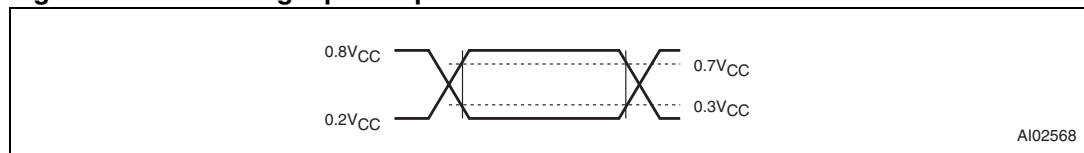

Table 4. DC and AC characteristics

Sym	Description	Test condition <sup>(1)</sup>	Min	Typ	Max	Unit		
V <sub>CC</sub>	Operating voltage	T <sub>A</sub> = -40 to +85 °C	1.2		5.5	V		
		T <sub>A</sub> = 0 to +70 °C	1.0		5.5	V		
I <sub>CC</sub>	V <sub>CC</sub> supply current	V <sub>CC</sub> < 3.6 V		5.5	10	μA		
		V <sub>CC</sub> < 5.5 V		7	15	μA		
I <sub>LO</sub>	Open drain reset output leakage current	V <sub>CC</sub> > V <sub>RST</sub> Reset not asserted	-1		+1	μA		
V <sub>OL</sub>	$\overline{\text{RST}}$ output low voltage	STM1001R/S/T only, I <sub>OL</sub> = 1.2 mA V <sub>CC</sub> = V <sub>RST</sub> (min)			0.3	V		
		STM1001L/M only, I <sub>OL</sub> = 3.2 mA V <sub>CC</sub> = V <sub>RST</sub> (min)			0.4	V		
V <sub>OL</sub>	$\overline{\text{RST}}$ output low voltage	I <sub>OL</sub> = 50 μA; V <sub>CC</sub> > 1.0 V			0.3	V		
<b>RESET thresholds</b>								
V <sub>RST</sub>	Reset threshold	STM1001L	25 °C	4.56	4.63	4.70	V	
			-40 to 85 °C	4.50		4.75	V	
		STM1001M	25 °C	4.31	4.38	4.45	V	
			-40 to 85 °C	4.25		4.50	V	
		STM1001T	25 °C	3.04	3.08	3.11	V	
			-40 to 85 °C	3.00		3.15	V	
		STM1001S	25 °C	2.89	2.93	2.96	V	
			-40 to 85 °C	2.85		3.00	V	
		STM1001R	25 °C	2.59	2.63	2.66	V	
			-40 to 85 °C	2.55		2.70	V	
			V <sub>RST</sub> temperature coefficient	V <sub>CC</sub> = 3.3 V		45		ppm/°C
			V <sub>CC</sub> to $\overline{\text{RST}}$ delay	V <sub>CC</sub> = V <sub>RST</sub> to (V <sub>RST</sub> - 100 mV)	STM1001L/M	40		μs
STM1001R/S/T	20				μs			
t <sub>rec</sub>	$\overline{\text{RST}}$ pulse width	Option B (refer to <a href="#">Table 6</a> )	20	30	40	ms		
		Option "Blank" (refer to <a href="#">Table 6</a> )	140	210	280			

1. Valid for ambient operating temperature: T<sub>A</sub> = -40 to 85 °C; V<sub>CC</sub> = 1.2 V to 5.5 V (except where noted).

## 6 Package mechanical data

In order to meet environmental requirements, ST offers these devices in different grades of ECOPACK® packages, depending on their level of environmental compliance. ECOPACK® specifications, grade definitions and product status are available at: [www.st.com](http://www.st.com). ECOPACK® is an ST trademark.

**Figure 12. SOT23-3 – 3-lead small outline transistor package outline**

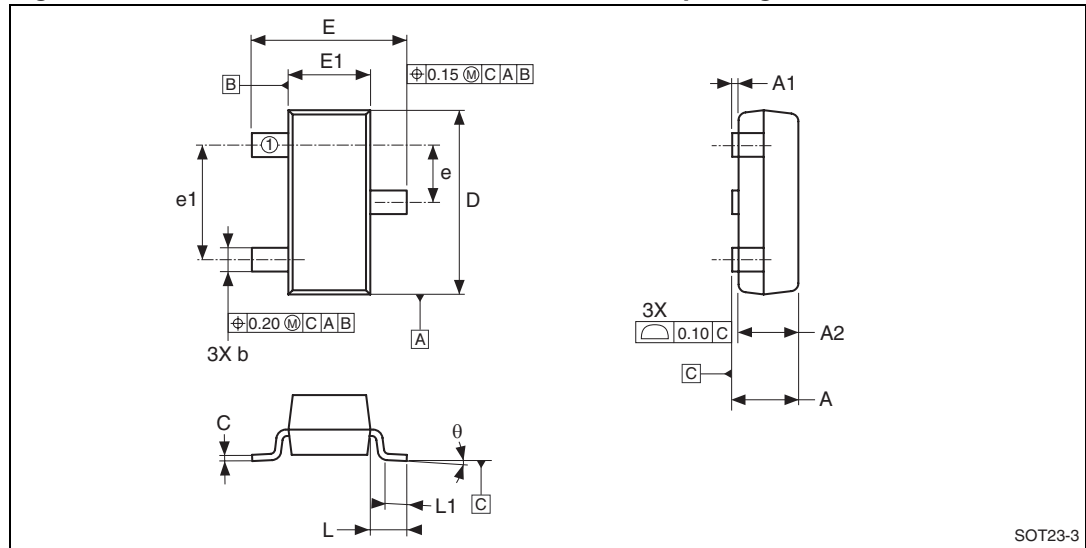

Note: Drawing is not to scale.

**Table 5. SOT23-3 – 3-lead small outline transistor package mechanical data**

Symbol	mm			inches		
	Typ	Min	Max	Typ	Min	Max
A		0.89	1.12		0.035	0.044
A1		0.01	0.10		0.001	0.004
A2		0.88	1.02		0.035	0.042
b		0.30	0.50		0.012	0.020
C		0.08	0.20		0.003	0.008
D		2.80	3.04		0.110	0.120
E		2.10	2.64		0.083	0.104
E1		1.20	1.40		0.047	0.055
e		0.89	1.03		0.035	0.041
e1		1.78	2.05		0.070	0.081
L	0.54			0.021		
L1		0.40	0.60		0.016	0.024
Q		0°	8°		0°	8°
N		3			3	

# 7 Part numbering

**Table 6. Ordering information scheme**

Example:	STM1001	S	B	WX	6	F
<b>Device type</b>						
STM1001						
<b>Reset threshold voltage</b>						
L = $V_{RST} = 4.50\text{ V to }4.75\text{ V}$						
M = $V_{RST} = 4.25\text{ V to }4.50\text{ V}$						
T = $V_{RST} = 3.00\text{ V to }3.15\text{ V}$						
S = $V_{RST} = 2.85\text{ V to }3.00\text{ V}$						
R = $V_{RST} = 2.55\text{ V to }2.70\text{ V}$						
<b>RST pulse width (<math>t_{rec}</math>)</b>						
B = 20 to 40 ms						
Blank = 140 to 280 ms						
<b>Package</b>						
WX = SOT23-3						
<b>Temperature range</b>						
6 = $-40\text{ to }85\text{ }^{\circ}\text{C}$						
<b>Shipping method</b>						
F = ECOPACK® package, tape & reel						

For other options, or for more information on any aspect of this device, please contact the ST sales office nearest you.

**Table 7. Marking description**

Part number	Reset threshold	Output	Topside marking <sup>(1)</sup>
STM1001LWX6F	4.63 V	Open drain $\overline{\text{RST}}$	8BAx
STM1001MWX6F	4.38 V	Open drain $\overline{\text{RST}}$	8BBx
STM1001TWX6F	3.08 V	Open drain $\overline{\text{RST}}$	8BCx
STM1001SWX6F	2.93 V	Open drain $\overline{\text{RST}}$	8BDx
STM1001RWX6F	2.63 V	Open drain $\overline{\text{RST}}$	8BEx
STM1001SBWX6F	2.93 V	Open drain $\overline{\text{RST}}$	8BMx

1. Lowercase "x" indicates date code.



## 8 Revision history

**Table 8. Document revision history**

Date	Revision	Changes
09-Dec-2003	1	First edition
19-Feb-2004	2	Part number changed from STM6301
22-Mar-2004	2.1	Update DC characteristics ( <a href="#">Table 4</a> )
09-Apr-2004	3	Device promoted; reformatted; marking updated ( <a href="#">Table 7</a> )
19-Nov-2004	4	Update dimensions ( <a href="#">Table 5</a> ).
19-Sep-2005	5	Remove "Valid RST Output Down to V <sub>CC</sub> ..." text
17-Feb-2010	6	Updated <a href="#">Features</a> ; footnote in <a href="#">Table 2</a> ; <a href="#">Table 4</a> ; <a href="#">Table 6</a> ; <a href="#">Table 7</a> ; text in <a href="#">Section 6</a> ; added note to <a href="#">Figure 8</a> ; reformatted document.

**Please Read Carefully:**

Information in this document is provided solely in connection with ST products. STMicroelectronics NV and its subsidiaries ("ST") reserve the right to make changes, corrections, modifications or improvements, to this document, and the products and services described herein at any time, without notice.

All ST products are sold pursuant to ST's terms and conditions of sale.

Purchasers are solely responsible for the choice, selection and use of the ST products and services described herein, and ST assumes no liability whatsoever relating to the choice, selection or use of the ST products and services described herein.

No license, express or implied, by estoppel or otherwise, to any intellectual property rights is granted under this document. If any part of this document refers to any third party products or services it shall not be deemed a license grant by ST for the use of such third party products or services, or any intellectual property contained therein or considered as a warranty covering the use in any manner whatsoever of such third party products or services or any intellectual property contained therein.

**UNLESS OTHERWISE SET FORTH IN ST'S TERMS AND CONDITIONS OF SALE ST DISCLAIMS ANY EXPRESS OR IMPLIED WARRANTY WITH RESPECT TO THE USE AND/OR SALE OF ST PRODUCTS INCLUDING WITHOUT LIMITATION IMPLIED WARRANTIES OF MERCHANTABILITY, FITNESS FOR A PARTICULAR PURPOSE (AND THEIR EQUIVALENTS UNDER THE LAWS OF ANY JURISDICTION), OR INFRINGEMENT OF ANY PATENT, COPYRIGHT OR OTHER INTELLECTUAL PROPERTY RIGHT.**

**UNLESS EXPRESSLY APPROVED IN WRITING BY AN AUTHORIZED ST REPRESENTATIVE, ST PRODUCTS ARE NOT RECOMMENDED, AUTHORIZED OR WARRANTED FOR USE IN MILITARY, AIR CRAFT, SPACE, LIFE SAVING, OR LIFE SUSTAINING APPLICATIONS, NOR IN PRODUCTS OR SYSTEMS WHERE FAILURE OR MALFUNCTION MAY RESULT IN PERSONAL INJURY, DEATH, OR SEVERE PROPERTY OR ENVIRONMENTAL DAMAGE. ST PRODUCTS WHICH ARE NOT SPECIFIED AS "AUTOMOTIVE GRADE" MAY ONLY BE USED IN AUTOMOTIVE APPLICATIONS AT USER'S OWN RISK.**

Resale of ST products with provisions different from the statements and/or technical features set forth in this document shall immediately void any warranty granted by ST for the ST product or service described herein and shall not create or extend in any manner whatsoever, any liability of ST.

ST and the ST logo are trademarks or registered trademarks of ST in various countries.

Information in this document supersedes and replaces all information previously supplied.

The ST logo is a registered trademark of STMicroelectronics. All other names are the property of their respective owners.

© 2010 STMicroelectronics - All rights reserved

STMicroelectronics group of companies

Australia - Belgium - Brazil - Canada - China - Czech Republic - Finland - France - Germany - Hong Kong - India - Israel - Italy - Japan - Malaysia - Malta - Morocco - Philippines - Singapore - Spain - Sweden - Switzerland - United Kingdom - United States of America

[www.st.com](http://www.st.com)



Компания «ЭлектроПласт» предлагает заключение долгосрочных отношений при поставках импортных электронных компонентов на взаимовыгодных условиях!

Наши преимущества:

- Оперативные поставки широкого спектра электронных компонентов отечественного и импортного производства напрямую от производителей и с крупнейших мировых складов;
- Поставка более 17-ти миллионов наименований электронных компонентов;
- Поставка сложных, дефицитных, либо снятых с производства позиций;
- Оперативные сроки поставки под заказ (от 5 рабочих дней);
- Экспресс доставка в любую точку России;
- Техническая поддержка проекта, помощь в подборе аналогов, поставка прототипов;
- Система менеджмента качества сертифицирована по Международному стандарту ISO 9001;
- Лицензия ФСБ на осуществление работ с использованием сведений, составляющих государственную тайну;
- Поставка специализированных компонентов (Xilinx, Altera, Analog Devices, Intersil, Interpoint, Microsemi, Aeroflex, Peregrine, Syfer, Eurofarad, Texas Instrument, Miteq, Cobham, E2V, MA-COM, Hittite, Mini-Circuits, General Dynamics и др.);

Помимо этого, одним из направлений компании «ЭлектроПласт» является направление «Источники питания». Мы предлагаем Вам помощь Конструкторского отдела:

- Подбор оптимального решения, техническое обоснование при выборе компонента;
- Подбор аналогов;
- Консультации по применению компонента;
- Поставка образцов и прототипов;
- Техническая поддержка проекта;
- Защита от снятия компонента с производства.



#### Как с нами связаться

**Телефон:** 8 (812) 309 58 32 (многоканальный)

**Факс:** 8 (812) 320-02-42

**Электронная почта:** [org@eplast1.ru](mailto:org@eplast1.ru)

**Адрес:** 198099, г. Санкт-Петербург, ул. Калинина, дом 2, корпус 4, литера А.