

## SDP600 Series (SDP6xx/5xx)

### Low-cost Digital Differential Pressure Sensor

- Accuracy better than 0.2% FS near zero
- Digital output (I<sup>2</sup>C)
- Excellent repeatability, even below 10 Pa
- Calibrated and temperature compensated
- Excellent long-term stability
- Flow measurement in bypass configuration



#### Product Summary

The SDP600 sensor family is Sensirion's series of digital differential pressure sensors designed for high-volume applications. They measure the pressure of **air and non-aggressive gases** with superb accuracy and no offset drift. The sensors cover a **pressure range of up to ±500 Pa** ( $\pm 2$  inch H<sub>2</sub>O /  $\pm 5$  mbar) and deliver **outstanding accuracy** even at the bottom end of the measuring range.

The SDP600 series operates from a 3.3V supply voltage and features a digital 2-wire interface, which makes it easy to connect directly to a microprocessor. The signal is internally **linearized** and **temperature compensated**.

The outstanding performance of these sensors is based on Sensirion's **patented CMOSens® sensor technology**, which combines the sensor element, signal processing and digital calibration on a tiny microchip. The differential pressure is measured by a thermal sensor element using flow-through technology. Compared with membrane-based sensors, the SDP600 features an **extended dynamic range**, better **long-term stability**, and improved repeatability, especially near zero.

The well-proven CMOS technology is perfectly suited for high-quality mass production and is the ideal choice for **demanding** and **cost-sensitive OEM applications**.

#### Applications

- Medical
- HVAC
- Automotive
- Process automation
- Burner control

#### Sensor chip

The SDP600 series features a fourth-generation silicon sensor chip called SF04. In addition to a thermal mass flow sensor element, the chip contains an amplifier, A/D converter, EEPROM memory, digital signal processing circuitry, and interface. The highly sensitive chip requires only a minuscule amount of gas flow through the sensor.

#### OEM options

A variety of custom options can be implemented for high-volume OEM applications. Ask us for more information.

## 1. Sensor Performance

### 1.1 Physical specifications<sup>1</sup>

Parameter	SDP600-500Pa SDP610-500Pa	SDP600-125Pa SDP610-125Pa	SDP600-25Pa SDP610-25Pa	SDP601 SDP611	SDP500 SDP510	SDP501 SDP511
Short Description	Standard	Low DP	Lowest DP	“Mass Flow”	Low cost	Low cost “Mass Flow”
Calibrated range <sup>2</sup>	- 500 Pa to + 500 Pa (± 2.0 in. H <sub>2</sub> O)	- 125 Pa to + 125 Pa (± 0.5 in. H <sub>2</sub> O)	- 25 Pa to + 25 Pa (± 0.1 in. H <sub>2</sub> O)	- 500 to + 500 Pa (± 2.0 in. H <sub>2</sub> O)	0 Pa to +500 Pa (0 to 2.0 in. H <sub>2</sub> O)	
Temperature-compensation	yes	yes	yes	mass flow <sup>3</sup>	yes	mass flow <sup>3</sup>
Resolution	12 bits preset <sup>4</sup> (adjustable from 9 to 16 bit)					
Zero point accuracy <sup>5,6</sup>	0.2 Pa	0.1 Pa		0.2 Pa		
Span accuracy <sup>5,6</sup>	3% of reading				4.5% of reading	
Zero point repeatability <sup>5,6</sup>	0.1 Pa	0.05 Pa	0.03 Pa	0.1 Pa		
Span repeatability <sup>5,6</sup>	0.5% of reading					
Offset shift due to temperature variation	None (less than resolution)					
Span shift due to temperature variation	< 0.5% of reading per 10°C					
Offset stability	< 0.1 Pa/year					
Response time <sup>4</sup>	4.6 ms typical at 12-bit resolution					
Warm-up time for first reliable measurement	Typ. 50 ms (first measurement typically after 16 ms)					

<sup>1</sup> Unless otherwise noted, all sensor specifications are valid at 25°C with V<sub>dd</sub> = 3.3 V and absolute pressure = 966 mbar.

<sup>2</sup> The SDP50x/SDP51x sensors can detect negative differential pressures in the range of -500 to 0Pa. A negative differential pressure is represented by a negative value. The accuracy of the negative differential pressure is not specified and might have significant inter-sensor variation.

<sup>3</sup> Please see chapter 5.3 for details.

<sup>4</sup> See Application Note for response times with other resolutions, e.g. 1.3 ms with 10 bits.

<sup>5</sup> With 12-bit resolution; includes repeatability and hysteresis.

<sup>6</sup> Total accuracy/repeatability is a sum of zero-point and span accuracy/repeatability.

## 1.2 Ambient conditions

Parameter	SDP5xx / SDP6xx Series
Calibrated for <sup>7</sup>	Air, N <sub>2</sub>
Media compatibility	Air, N <sub>2</sub> , O <sub>2</sub>
Calibrated temperature range	-20 °C to +80 °C
Operating temperature	-20 °C to +80 °C
Storage temperature <sup>7</sup>	-40 °C to +80 °C
Position sensitivity	Less than repeatability error

## 1.3 Materials

Parameter	SDP5xx / SDP6xx Series
Wetted materials	PBT (polybutylene terephthalate), glass (silicon nitride, silicon oxide), silicon, gold, FR4, silicone as static sealing, epoxy, copper alloy, lead-free solder
REACH, RoHS	REACH and RoHS compliant

## 2. Electrical Specifications

Parameter	SDP5xx / SDP6xx
Operating voltage	3.0– 3.6 V (A supply voltage of 3.3 V is recommended)
Current drain	< 6 mA typical in operation
Interface	Digital 2-wire interface (I <sup>2</sup> C)
Bus clock frequency	100 kHz typical, 400 kHz max.
Default I <sup>2</sup> C address	64 (binary: 1000 000)
<b>Scale factor<sup>8</sup></b>	
SDP6xx-500Pa & SDP5xx	60 Pa <sup>-1</sup>
SDP6x0-125Pa	240 Pa <sup>-1</sup>
SDP6x0-25Pa	1200 Pa <sup>-1</sup>
Scale factor to alternative units <sup>9</sup>	For all 500 Pa versions: 6'000 mbar <sup>-1</sup> 413'686 psi <sup>-1</sup> 14'945 (inch H <sub>2</sub> O) <sup>-1</sup>
SDP 6x0-125Pa	24'000 mbar <sup>-1</sup> 1'654'744 psi <sup>-1</sup> 59'780 (inch H <sub>2</sub> O) <sup>-1</sup>
SDP6x0-25Pa	120'000 mbar <sup>-1</sup> 8'273'719 psi <sup>-1</sup> 298'900 (inch H <sub>2</sub> O) <sup>-1</sup>

<sup>7</sup> Contact Sensirion for information about other gases, wider calibrated temperature ranges and higher storage temperatures.

<sup>8</sup> See section 5.1. The scale factor may vary with other configurations.

<sup>9</sup> Instead of the standard scale factor (to get the physical value in Pa), the sensor output may be divided by alternative scale factors to receive the physical value in another unit.

### 3. Interface Specifications

The serial interface of the SDP600 series is compatible with I<sup>2</sup>C interfaces. For detailed specifications of the I<sup>2</sup>C protocol, see *The I<sup>2</sup>C Bus Specification* (source: NXP).

#### 3.1 Interface connection – external components

Bi-directional bus lines are implemented by the devices (master and slave) using open-drain output stages and a pull-up resistor connected to the positive supply voltage.

The recommended pull-up resistor value depends on the system setup (capacitance of the circuit or cable and bus clock frequency). In most cases, 10 kΩ is a reasonable choice.

The capacitive loads on SDA and SCL line have to be the same. It is important to avoid asymmetric capacitive loads.

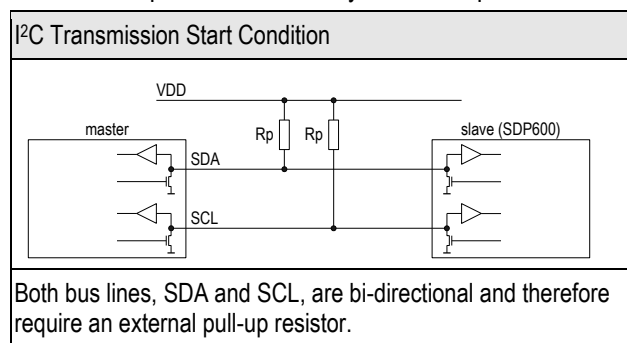

#### 3.2 I<sup>2</sup>C Address

The I<sup>2</sup>C address consists of a 7-digit binary value. By default, the I<sup>2</sup>C address is set to 64 (binary: 1000 000). The address is always followed by a write bit (0) or read bit (1). The default hexadecimal I<sup>2</sup>C header for read access to the sensor is therefore h81.

#### 3.3 Transfer sequences

**Transmission START Condition (S):** The START condition is a unique situation on the bus created by the master, indicating to the slaves the beginning of a transmission sequence (the bus is considered busy after a START).

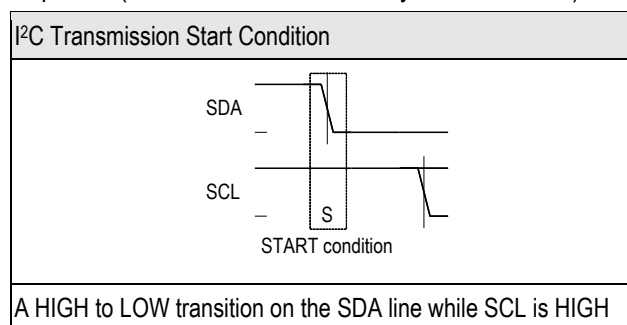

**Transmission STOP Condition (P):** The STOP condition is a unique situation on the bus created by the master, indicating to the slaves the end of a transmission sequence (the bus is considered free after a STOP).

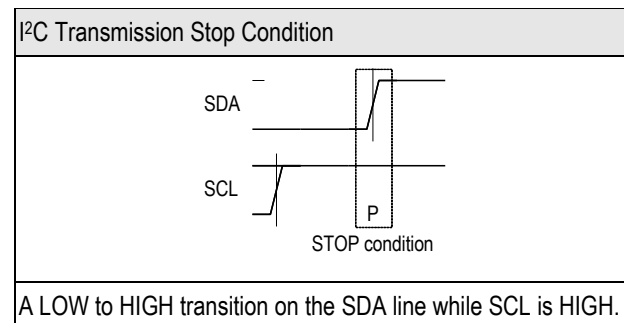

**Acknowledge (ACK) / Not Acknowledge (NACK):** Each byte (8 bits) transmitted over the I<sup>2</sup>C bus is followed by an acknowledge condition from the receiver. This means that after the master pulls SCL low to complete the transmission of the 8th bit, SDA will be pulled low by the receiver during the 9th bit time. If after transmission of the 8th bit the receiver does not pull the SDA line low, this is considered to be a NACK condition.

If an ACK is missing during a slave to master transmission, the slave aborts the transmission and goes into idle mode.

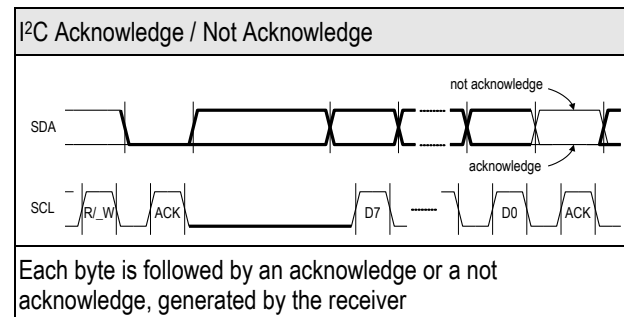

**Handshake procedure (Hold Master):** In a master-slave system, the master dictates when the slaves will receive or transmit data. However, in some situations a slave device may need time to store received data or prepare data to be transmitted. Therefore, a handshake procedure is required to allow the slave to indicate termination of internal processing.

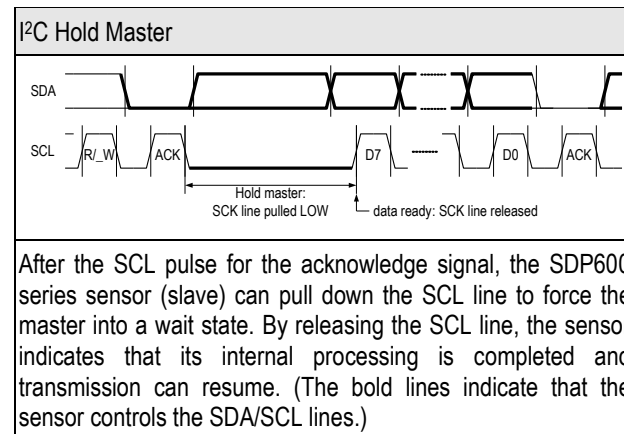

### 3.4 Data transfer format

Data is transferred in byte packets in the I<sup>2</sup>C protocol, which means in 8-bit frames. Each byte is followed by an acknowledge bit. Data is transferred with the most significant bit (MSB) first.

A data transfer sequence is initiated by the master generating the Start condition (S) and sending a header byte. The I<sup>2</sup>C header consists of the 7-bit I<sup>2</sup>C device address and the data direction bit (R/\_W).

The value of the R/\_W bit in the header determines the data direction for the rest of the data transfer sequence. If R/\_W = 0 (WRITE) the direction remains master-to-slave, while if R/\_W = 1 (READ) the direction changes to slave-to-master after the header byte.

## 4. Command Set and Data Transfer Sequences

A command is represented by an 8-bit command code. The data direction may not change after the command byte, since the R/\_W bit of the preceding I<sup>2</sup>C header has already determined the direction to be master-to-slave. In order to execute commands in Read mode using I<sup>2</sup>C, the following principle is used. On successful (acknowledged) receipt of a command byte, the sensor stores the command nibble internally. The Read mode of this command is then invoked by initiating an I<sup>2</sup>C data transfer sequence with R/\_W = 1.

If a correctly addressed sensor recognizes a valid command and access to this command is granted, it responds by pulling down the SDA line during the subsequent SCL pulse for the acknowledge signal (ACK). Otherwise it leaves the SDA line unasserted (NACK).

The two most important commands are described in this data sheet, and the data transfer sequences are specified. Contact Sensirion for advanced sensor options.

### 4.1 Measurement triggering

Each individual measurement is triggered by a separate read operation.

Note that two transfer sequences are needed to perform a measurement. First write command byte hF1 (trigger measurement) to the sensor, and then execute a read operation to trigger the measurement and retrieve the flow or differential pressure information.

On receipt of a header with R/\_W=1, the sensor generates the Hold Master condition on the bus until the first measurement is completed. After the Hold Master condition is released, the master can read the result as two consecutive bytes. A CRC byte follows if the master continues clocking the SCL line after the second result

byte. The sensor checks whether the master sends an acknowledge after each byte and aborts the transmission if it does not.

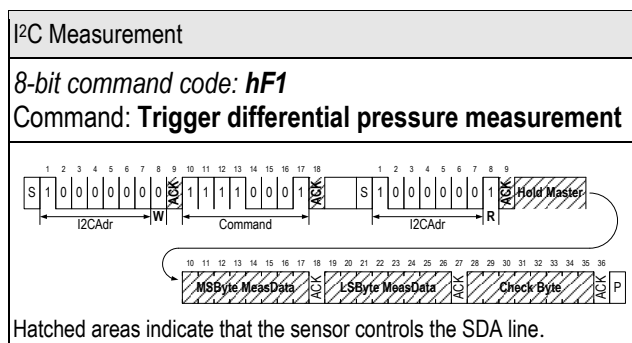

Note that the first measurement result after reset is not valid.

### 4.2 Soft reset

This command forces a sensor reset without switching the power off and on again. On receipt of this command, the sensor reinitializes the control/status register contents from the EEPROM and starts operating according to these settings.

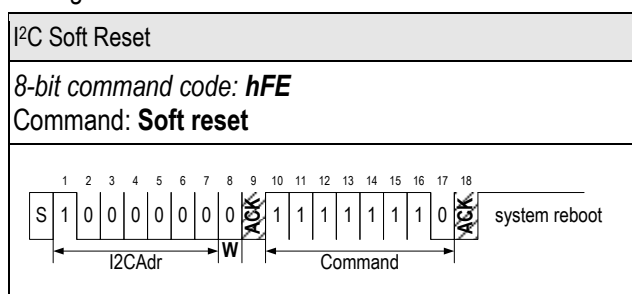

### 4.3 CRC-8 Redundant Data Transmission

Cyclic redundancy checking (CRC) is a popular technique used for error detection in data transmission. The transmitter appends an n-bit checksum to the actual data sequence. The checksum holds redundant information about the data sequence and allows the receiver to detect transmission errors. The computed checksum can be regarded as the remainder of a polynomial division, where the dividend is the binary polynomial defined by the data sequence and the divisor is a "generator polynomial".

The sensor implements the CRC-8 standard based on the generator polynomial

$$x^8 + x^5 + x^4 + 1.$$

Note that CRC protection is only used for data transmitted from the slave to the master.

For details regarding cyclic redundancy checking, please refer to the relevant literature.

## 5. Conversion to Physical Values

### 5.1 Signal scaling and physical unit

The calibrated signal read from the sensor is a signed INTEGER number (two's complement number). The INTEGER value can be converted to the physical value by dividing it by the scale factor (pressure = sensor output ÷ scale factor). The scale factor is specified in Section 2.

### 5.2 Temperature compensation

The SDP600 sensor series features digital temperature compensation. The temperature is measured on the CMOSens® chip by an on-chip temperature sensor. This data is fed to a compensation circuit that is also integrated on the CMOSens® sensor chip. No external temperature compensation is necessary.

### 5.3 Mass flow temperature compensation

A sensor output proportional to mass flow is necessary for measuring mass flow in a bypass configuration. Even though the output of the SDP sensors with mass flow temperature compensation is still differential pressure, the temperature compensation is adapted especially for mass flow measurements in a bypass configuration. At calibration temperature both calibrations are equivalent. Please find the application note "Bypass Configuration Differential Pressure Sensor SDPxxx" on our website.

### 5.4 Altitude correction

The SDP600 sensor series achieves its unsurpassed performance by using a dynamic measurement principle. The applied differential pressure forces a small flow of gas through the sensor, which is measured by the flow sensor element. As a result, any variation in gas density affects the sensor reading. While temperature effects are compensated internally, variations in atmospheric pressure (elevation above sea level) can be compensated by a correction factor according to the following formula:

$$DP_{\text{eff}} = DP_{\text{sensor}} \times (P_{\text{cal}} / P_{\text{amb}})$$

DP<sub>eff</sub>: Effective differential pressure

DP<sub>sensor</sub>: Differential pressure indicated by the sensor

P<sub>cal</sub>: Absolute pressure at calibration (966 mbar)

P<sub>amb</sub>: Actual ambient absolute pressure.

Altitude correction factors:

Altitude [meters]	Ambient pressure (P <sub>amb</sub> ) [mbar]	Correction factor (P <sub>cal</sub> / P <sub>amb</sub> )
0	1013	0.95
250	984	0.98
425	966	1.00
500	958	1.01
750	925	1.04

1500	842	1.15
2250	766	1.26
3000	697	1.38

**Example:** At 750 m above sea level and a sensor reading of 40 Pa, the effective differential pressure is 41.8 Pa.

**Note:** In many HVAC applications such as air flow measurement in a bypass configuration, the described dependence on absolute pressure is actually welcome because the quantity that must effectively be controlled is the mass flow and not the volume flow. Mass flow is dependent on differential pressure and absolute pressure. For details please refer to our application note "Measuring Flow in a Bypass Configuration".

## 6. OEM Options

A variety of custom options can potentially be implemented for high-volume OEM applications. Contact Sensirion for more information.



## 8. Instructions for Use

### 8.1 Soldering instructions

Standard wave soldering systems may be used for soldering SDP600 series sensors. Reflow soldering is **not** feasible and may damage the sensor.

The sensor ports must be protected from solder splash and flux during soldering. Figure 6 shows an appropriate temperature profile with maximum temperature values.

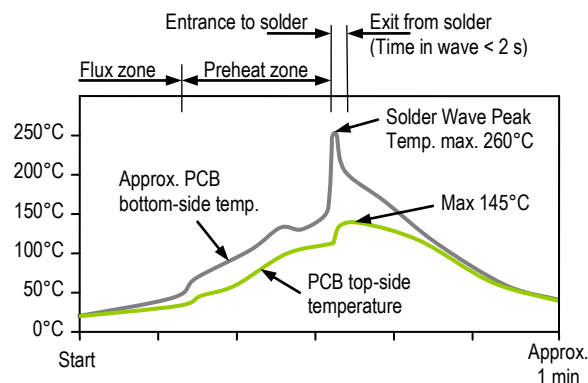

**Figure 6:** Suitable wave soldering profile.

The characteristics of wave soldering machines vary, so any soldering setup must be tested before production use.

### 8.2 Sensor handling

The sensors of the SDP600 series are designed to be robust and vibration resistant. Nevertheless, the accuracy of the high-precision SDP600 series can be degraded by rough handling. Sensirion does not guarantee proper operation in case of improper handling. **Note:** avoid applying any mechanical stress to the solder joints of the sensor during or as a result of PCB assembly.

The sensor ships in an antistatic package to prevent electrostatic discharge (ESD), which can damage the part. To avoid such damage, ground yourself using a grounding strap or by touching a grounded object. Furthermore store the parts in the antistatic package when not in use.

### 8.3 Additional attachment

If necessary, the robustness of the sensor attachment to the PCB can be increased by using a bracket as shown in Figure 7.

Sensirion recommends using this additional bracket when the sensor is fitted to a PCB. The bracket must be secured before the pins are soldered to the PCB, as otherwise sensor performance may be degraded by mechanical stress.

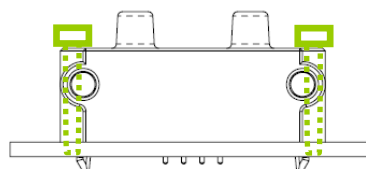

**Figure 7:** Supplementary bracket for the SDP600 series.

### 8.4 Air flow and tubing

Due to the dynamic measurement principle, a small air flow is required.

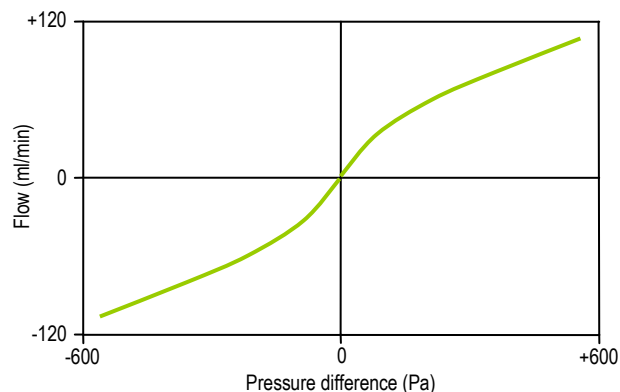

**Figure 8:** Typical air flow through the SDP600 series sensor.  
Note: 1 sccm = 1 cm<sup>3</sup>/min at 0°C and 1013 mbar  
(1 sccm = 0.001 standard liter).

This air flow through the sensor creates a dependence on the tube length. The error is less than 1% with a tube length up to 1 m (with 3/16 inch inside diameter).



## 9. Ordering Information

Use the part names and item numbers shown in the following table when ordering SDP600 series differential pressure sensors. For the latest product information and local distributors, visit [www.sensirion.com](http://www.sensirion.com).

Part name	Description / Output	Calibrated range	"Mass flow"	Span accuracy	Product number 1-10xxxx-xx
SDP500	I <sup>2</sup> C, manifold mount	0 to +500 Pa (0 to +2 in. H <sub>2</sub> O)		4.5%	0601-02
SDP510	I <sup>2</sup> C, tube connection	0 to +500 Pa (0 to +2 in. H <sub>2</sub> O)		4.5%	0602-02
SDP501	I <sup>2</sup> C, manifold mount	0 to +500 Pa (0 to +2 in. H <sub>2</sub> O)	x	4.5%	1314-01
SDP511	I <sup>2</sup> C, tube connection	0 to +500 Pa (0 to +2 in. H <sub>2</sub> O)	x	4.5%	1315-01
SDP600-500Pa	I <sup>2</sup> C, manifold mount	±500 Pa (±2 in. H <sub>2</sub> O)		3%	0456-02
SDP610-500Pa	I <sup>2</sup> C, tube connection	±500 Pa (±2 in. H <sub>2</sub> O)		3%	0455-02
SDP600-125Pa	I <sup>2</sup> C, manifold mount	±125 Pa (±0.5 in. H <sub>2</sub> O)		3%	0760-02
SDP610-125Pa	I <sup>2</sup> C, tube connection	±125 Pa (±0.5 in. H <sub>2</sub> O)		3%	0761-02
SDP600-25Pa	I <sup>2</sup> C, manifold mount	±25 Pa (±0.1 in. H <sub>2</sub> O)		3%	0758-02
SDP610-25Pa	I <sup>2</sup> C, tube connection	±25 Pa (±0.1 in. H <sub>2</sub> O)		3%	0759-02
SDP601-500Pa	I <sup>2</sup> C, manifold mount	±500 Pa (±2 in. H <sub>2</sub> O)	x	3%	0603-02
SDP611-500Pa	I <sup>2</sup> C, tube connection	±500 Pa (±2 in. H <sub>2</sub> O)	x	3%	0604-02

Packaging units: 80 items/tray and 480 items/box.

### 9.1 Packaging

**Housing:** The sensor housing consists of PBT. The device is fully RoHS compliant – it is free of Pb, Cd, Hg, Cr(6+), PBB and PBDE.

Each sensor is labeled by laser printing on the front side:

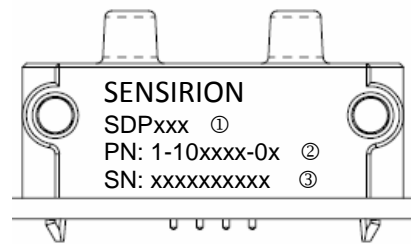

- ① Sensor type
- ② Sensirion product number
- ③ Serial number

Figure 9: Marking of the housing.

**Traceability Information:** SDPxxx are shipped in trays of 80pcs. The tray dimension is 355mm x 255mm x 21.5mm. By piling them up, the height per tray can be considered as 19mm. For traceability, each tray is marked with a label. No information can be derived from the code directly, respective data is stored at Sensirion AG and is provided upon request.

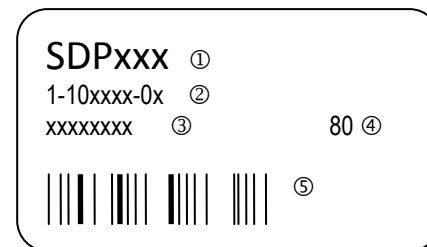

- ① Sensor type
- ② Sensirion item number
- ③ Lot number
- ④ Number of sensors inside tray
- ⑤ Barcode of lot number

Figure 10: Label sticking on each tray

### Revision history

Date	Author	Version	Changes
Sept, 2008	PHA	V1.0	Initial release
Nov, 2008	PHA	V1.1	Small amendments (power consumption, asymmetric lines and US office address)
Jan, 2009	PHA	V1.2	Explanation to SDP5x0 calibration range, media compatibility extended
Feb, 2009	PHA	V1.3	Packaging information added, sensor handling instruction
Nov, 2009	PHA	V1.4	Zero point accuracy changed. Supply voltage requirements and recommendations relaxed.
January, 2011	DAT	V1.5	Introduction of low power versions(SDP6x6) and low differential pressure versions SDP6xx-125Pa / SDP6xx-25Pa.
Feb, 2011	VVO	V1.6	Calibrated Temperature Range is extended, minor corrections
Sept, 2012	ANB	V1.7	Updated Product Number.
June, 2015	ANB	V1.8	Added SDP5x1. Moved SDP6x6 to separate datasheet. Minor updates.
July, 2015	ANB	V1.9	Fixed broken link in chapter 5.

## Important Notices

### Warning, personal injury

**Do not use this product as safety or emergency stop devices or in any other application where failure of the product could result in personal injury (including death). Do not use this product for applications other than its intended and authorized use. Before installing, handling, using or servicing this product, please consult the datasheet and application notes. Failure to comply with these instructions could result in death or serious injury.**

If the Buyer shall purchase or use SENSIRION products for any unintended or unauthorized application, Buyer shall defend, indemnify and hold harmless SENSIRION and its officers, employees, subsidiaries, affiliates and distributors against all claims, costs, damages and expenses, and reasonable attorney fees arising out of, directly or indirectly, any claim of personal injury or death associated with such unintended or unauthorized use, even if SENSIRION shall be allegedly negligent with respect to the design or the manufacture of the product.

### ESD Precautions

The inherent design of this component causes it to be sensitive to electrostatic discharge (ESD). To prevent ESD-induced damage and/or degradation, take customary and statutory ESD precautions when handling this product.

See application note "Handling Instructions" for more information.

### Warranty

SENSIRION warrants solely to the original purchaser of this product for a period of 12 months (one year) from the date of delivery that this product shall be of the quality, material and workmanship defined in SENSIRION's published specifications of the product. Within such period, if proven to be defective, SENSIRION shall repair and/or replace this product, in SENSIRION's discretion, free of charge to the Buyer, provided that:

- notice in writing describing the defects shall be given to SENSIRION within fourteen (14) days after their appearance;

- such defects shall be found, to SENSIRION's reasonable satisfaction, to have arisen from SENSIRION's faulty design, material, or workmanship;
- the defective product shall be returned to SENSIRION's factory at the Buyer's expense; and
- the warranty period for any repaired or replaced product shall be limited to the unexpired portion of the original period.

This warranty does not apply to any equipment which has not been installed and used within the specifications recommended by SENSIRION for the intended and proper use of the equipment. EXCEPT FOR THE WARRANTIES EXPRESSLY SET FORTH HEREIN, SENSIRION MAKES NO WARRANTIES, EITHER EXPRESS OR IMPLIED, WITH RESPECT TO THE PRODUCT. ANY AND ALL WARRANTIES, INCLUDING WITHOUT LIMITATION, WARRANTIES OF MERCHANTABILITY OR FITNESS FOR A PARTICULAR PURPOSE, ARE EXPRESSLY EXCLUDED AND DECLINED.

SENSIRION is only liable for defects of this product arising under the conditions of operation provided for in the datasheet and proper use of the goods. SENSIRION explicitly disclaims all warranties, express or implied, for any period during which the goods are operated or stored not in accordance with the technical specifications.

SENSIRION does not assume any liability arising out of any application or use of any product or circuit and specifically disclaims any and all liability, including without limitation consequential or incidental damages. All operating parameters, including without limitation recommended parameters, must be validated for each customer's applications by customer's technical experts. Recommended parameters can and do vary in different applications.

SENSIRION reserves the right, without further notice, (i) to change the product specifications and/or the information in this document and (ii) to improve reliability, functions and design of this product.

Copyright © 2001-2015, SENSIRION.  
CMOSens® is a trademark of Sensirion  
All rights reserved

## Headquarters and Subsidiaries

SENSIRION AG  
Laubisruetistr. 50  
CH-8712 Staefa ZH  
Switzerland

phone: +41 44 306 40 00  
fax: +41 44 306 40 30  
[info@sensirion.com](mailto:info@sensirion.com)  
[www.sensirion.com](http://www.sensirion.com)

Sensirion AG (Germany)  
phone: +41 44 927 11 66  
[info@sensirion.com](mailto:info@sensirion.com)  
[www.sensirion.com](http://www.sensirion.com)

Sensirion Inc., USA  
phone: +1 805 409 4900  
[info\\_us@sensirion.com](mailto:info_us@sensirion.com)  
[www.sensirion.com](http://www.sensirion.com)

Sensirion Japan Co. Ltd.  
phone: +81 3 3444 4940  
[info@sensirion.co.jp](mailto:info@sensirion.co.jp)  
[www.sensirion.co.jp](http://www.sensirion.co.jp)

Sensirion Korea Co. Ltd.  
phone: +82 31 337 7700~3  
[info@sensirion.co.kr](mailto:info@sensirion.co.kr)  
[www.sensirion.co.kr](http://www.sensirion.co.kr)

Sensirion China Co. Ltd.  
phone: +86 755 8252 1501  
[info@sensirion.com.cn](mailto:info@sensirion.com.cn)  
[www.sensirion.com.cn](http://www.sensirion.com.cn)

To find your local representative, please visit [www.sensirion.com/contact](http://www.sensirion.com/contact)



Компания «ЭлектроПласт» предлагает заключение долгосрочных отношений при поставках импортных электронных компонентов на взаимовыгодных условиях!

Наши преимущества:

- Оперативные поставки широкого спектра электронных компонентов отечественного и импортного производства напрямую от производителей и с крупнейших мировых складов;
- Поставка более 17-ти миллионов наименований электронных компонентов;
- Поставка сложных, дефицитных, либо снятых с производства позиций;
- Оперативные сроки поставки под заказ (от 5 рабочих дней);
- Экспресс доставка в любую точку России;
- Техническая поддержка проекта, помощь в подборе аналогов, поставка прототипов;
- Система менеджмента качества сертифицирована по Международному стандарту ISO 9001;
- Лицензия ФСБ на осуществление работ с использованием сведений, составляющих государственную тайну;
- Поставка специализированных компонентов (Xilinx, Altera, Analog Devices, Intersil, Interpoint, Microsemi, Aeroflex, Peregrine, Syfer, Eurofarad, Texas Instrument, Miteq, Cobham, E2V, MA-COM, Hittite, Mini-Circuits, General Dynamics и др.);

Помимо этого, одним из направлений компании «ЭлектроПласт» является направление «Источники питания». Мы предлагаем Вам помощь Конструкторского отдела:

- Подбор оптимального решения, техническое обоснование при выборе компонента;
- Подбор аналогов;
- Консультации по применению компонента;
- Поставка образцов и прототипов;
- Техническая поддержка проекта;
- Защита от снятия компонента с производства.



#### Как с нами связаться

**Телефон:** 8 (812) 309 58 32 (многоканальный)

**Факс:** 8 (812) 320-02-42

**Электронная почта:** [org@eplast1.ru](mailto:org@eplast1.ru)

**Адрес:** 198099, г. Санкт-Петербург, ул. Калинина, дом 2, корпус 4, литера А.