

THIS DRAWING IS UNPUBLISHED. RELEASED FOR PUBLICATION
 © COPYRIGHT - By - ALL RIGHTS RESERVED.

LOC		DIST		REVISIONS			
P	LTR	DESCRIPTION		DATE	DWN	APVD	
AD	00	A6	REVISED PER ECO-12-014385	28SEP12	KH	PO	

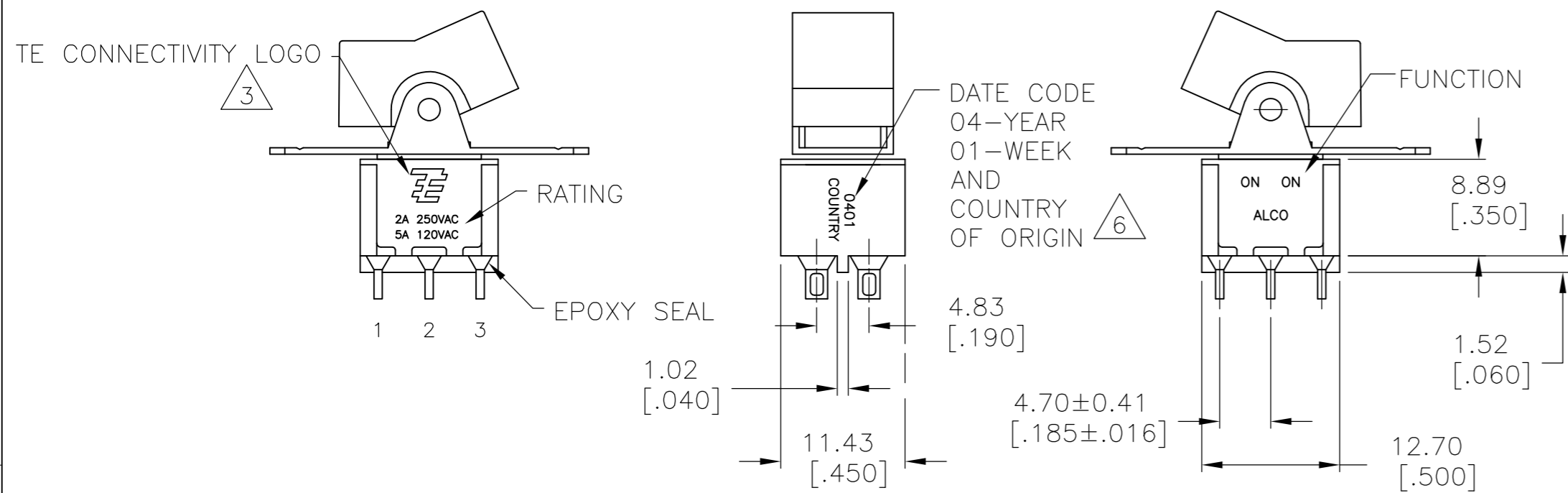

- ALL MATERIALS AND FINISHES SHALL COMPLY WITH EU DIRECTIVE 2002/95/EC OF 27JAN2003 (ROHS).
- G CONTACT OPTION CAN BE USED FOR SIGNAL OR POWER LEVEL SWITCHING. IF SWITCH IS USED AT LEVELS EXCEEDING .4VA @ 20V AC/DC, SWITCH IS RENDERED FOR POWER SWITCHING ONLY DUE TO ARC REMOVAL OF GOLD PLATING. RATING STAMPED ON THE SWITCH IS 2A 250VAC, 5A 120VAC.
- TE CONNECTIVITY LOGO PER PER TEC-202-36.
- SP3T FUNCTION ACHIEVED WITH FUNCTIONS 11, 13, & 15 BY CUSTOMER APPLIED JUMPER BETWEEN TERMINALS 3 & 5.
- DATE CODE AND COUNTRY OF ORIGIN MAY APPEAR ON EITHER SIDE OF SWITCH.
- PANEL MOUNT BRACKET SUPPLIED WITH TERMINALS W, Z AND Z3 ONLY.

FUNCTION CHART

FUNCTION			
01	ON	NONE	ON
03	ON	OFF	ON
05	(ON)	OFF	(ON)
07	ON	OFF	(ON)
08	ON	NONE	(ON)
TERMINALS CONNECTED	2-3, 5-6	---	1-2, 4-5
11	ON	ON	ON
13	ON	ON	(ON)
15	(ON)	ON	(ON)
TERMINALS CONNECTED	2-3, 5-6	2-3, 4-5	1-2, 4-5
SP3T SCHEMATIC (11, 13 & 15 ONLY) NOTE 5			
	IN 2, OUT 6	IN 2, OUT 4	IN 2, OUT 1

NONE: NO MECHANICAL POSITION
 OFF: MECHANICAL POSITION WITH NO ELECTRICAL CONNECTION
 (ON): MOMENTARY ACTION

SPECIFICATIONS

RATING, B CONTACTS	.4VA MAX @20V MAX. AC OR DC
RATING, G CONTACTS--SEE NOTE 2	.4VA MAX @20V MAX. AC OR DC OR 5A @120 VAC OR 28 VDC (RESISTIVE)
	2A @250 VAC (RESISTIVE)
RATING, Q CONTACTS	5A @120 VAC OR 28 VDC (RESISTIVE)
	2A @250 VAC (RESISTIVE)
ELECTRICAL LIFE	6,000 CYCLES AT RATED LOAD
CONTACT RESISTANCE	10 MILLIOHMS MAX INITIAL @ 2-4VDC, 100MA
INSULATION RESISTANCE	1,000 MEGOHMS MIN
DIELECTRIC WITHSTANDING VOLTAGE	1,000 V RMS AT SEA LEVEL
OPERATING TEMPRATURE	-30C TO 85C

PART NUMBER SEQUENCE

MODEL	FUNCTION	ACTUATOR	TERMINAL	CONTACT	ACTUATOR COLOR	FRAME COLOR	ROHS
A2							04
	01	J1	A	B	0 BLACK (STD)	0 BLACK (STD)	
	03	J3	AV2	G	1 BROWN	1 BROWN	
	05	J50	C	Q	2 RED	2 RED	
	07	J51	V3		3 ORANGE	3 ORANGE	
	08	J52	V4		4 YELLOW	4 YELLOW	
	11	J2	V7		5 GREEN	5 GREEN	
	13	J4	W		6 BLUE	6 BLUE	
	15	J60	W4		8 GRAY	8 GRAY	
		J61	Z		9 WHITE	9 WHITE	
		J62	Z3				

THIS DRAWING IS A CONTROLLED DOCUMENT.

DWN	M.BINNER	06JAN05
CHK	M.ZITTO	06JAN05
APVD	M.ZITTO	06JAN05
PRODUCT SPEC		
APPLICATION SPEC		
WEIGHT	-	
CUSTOMER DRAWING		

TE Connectivity

GEMINI A SERIES ROCKER SWITCH DOUBLE POLE

SCALE 2:1 SHEET 1 OF 5 REV A6

THIS DRAWING IS UNPUBLISHED. RELEASED FOR PUBLICATION
 © COPYRIGHT - By - ALL RIGHTS RESERVED.

LOC		DIST		REVISIONS			
P	LTR	DESCRIPTION	DATE	DWN	APVD		
AD	00	SEE SHEET 1	-	-	-		

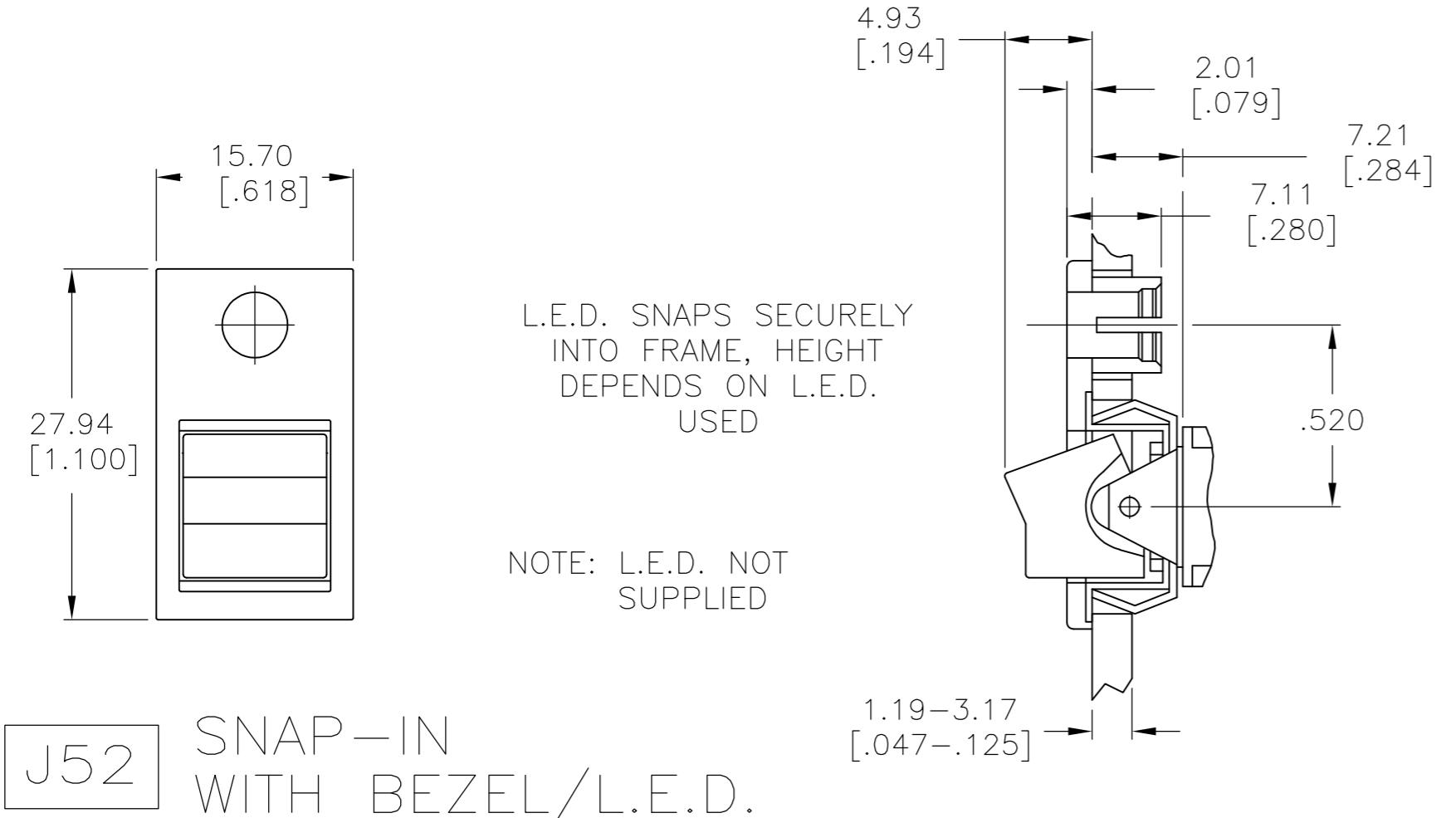
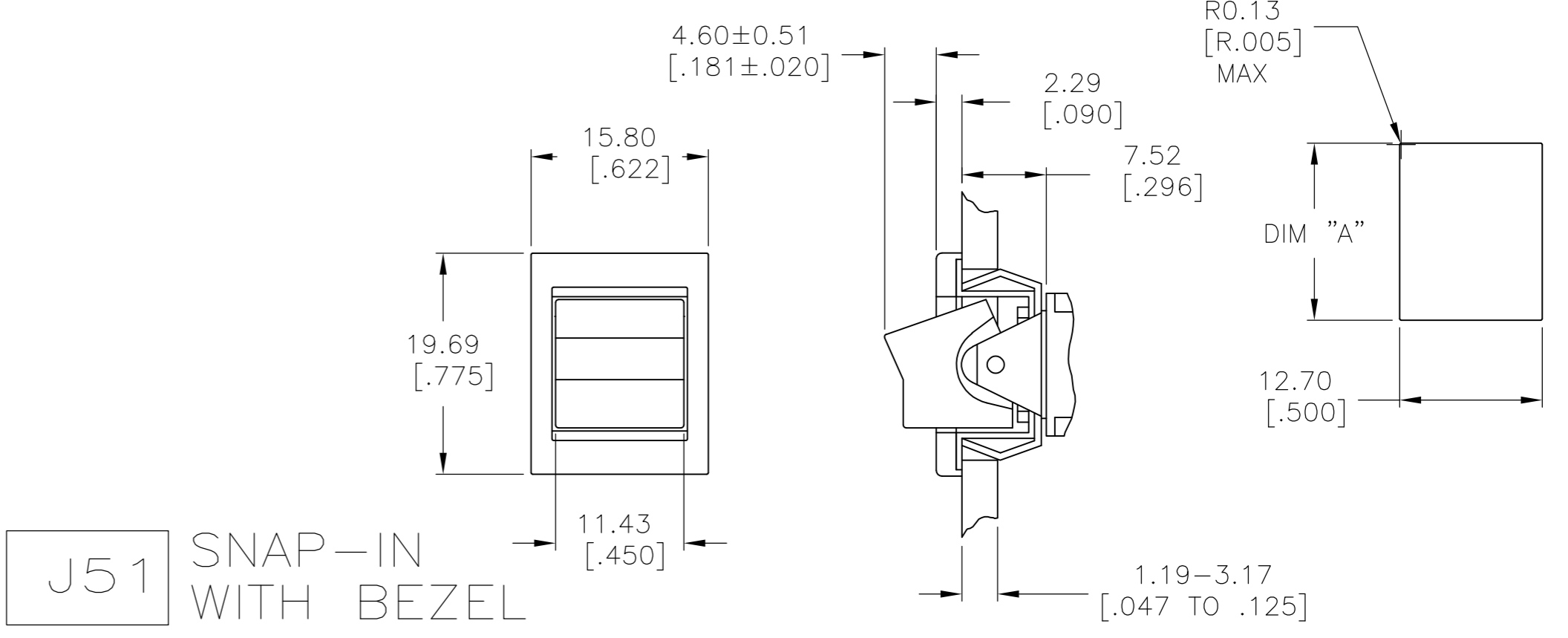
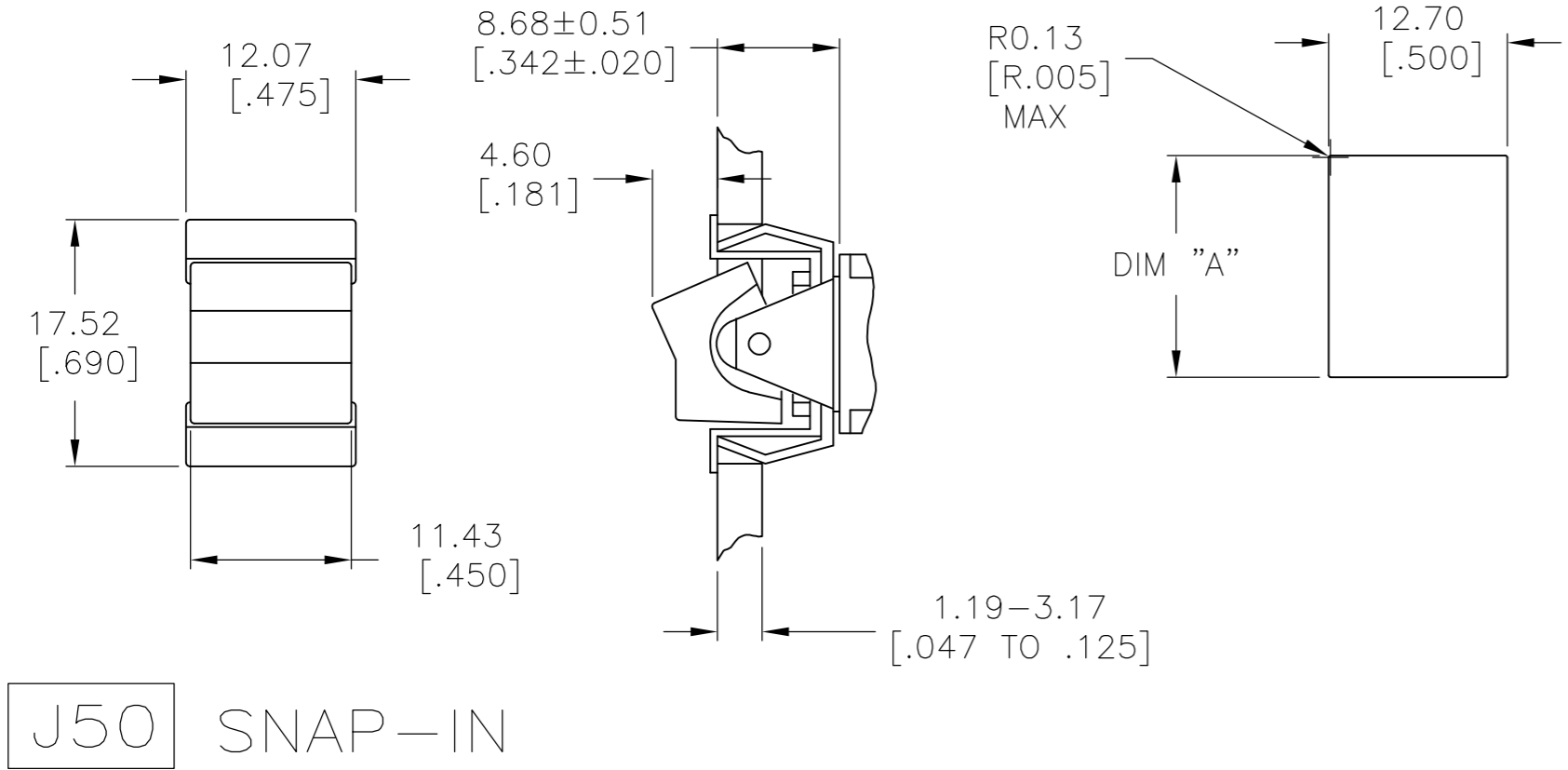
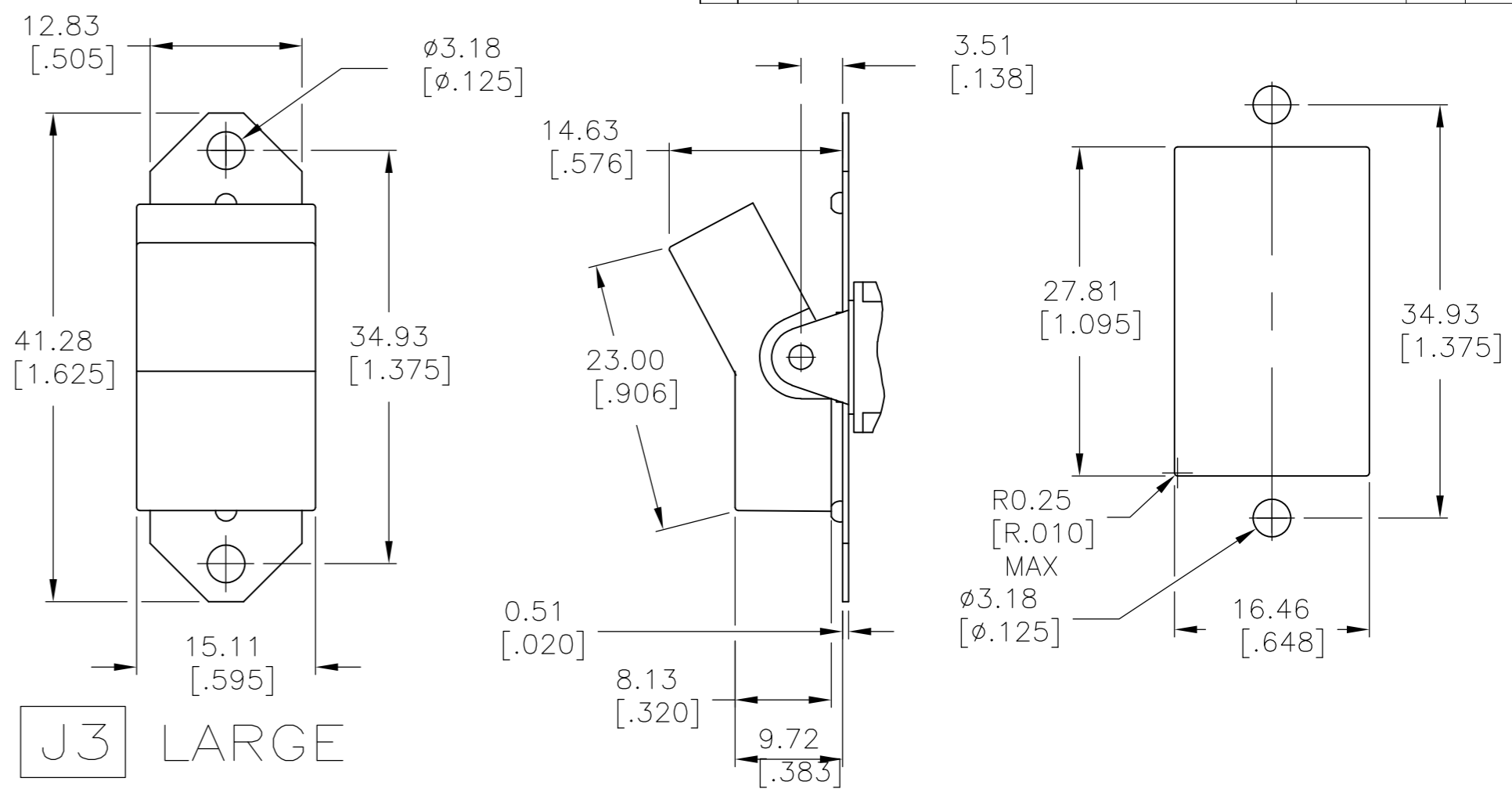
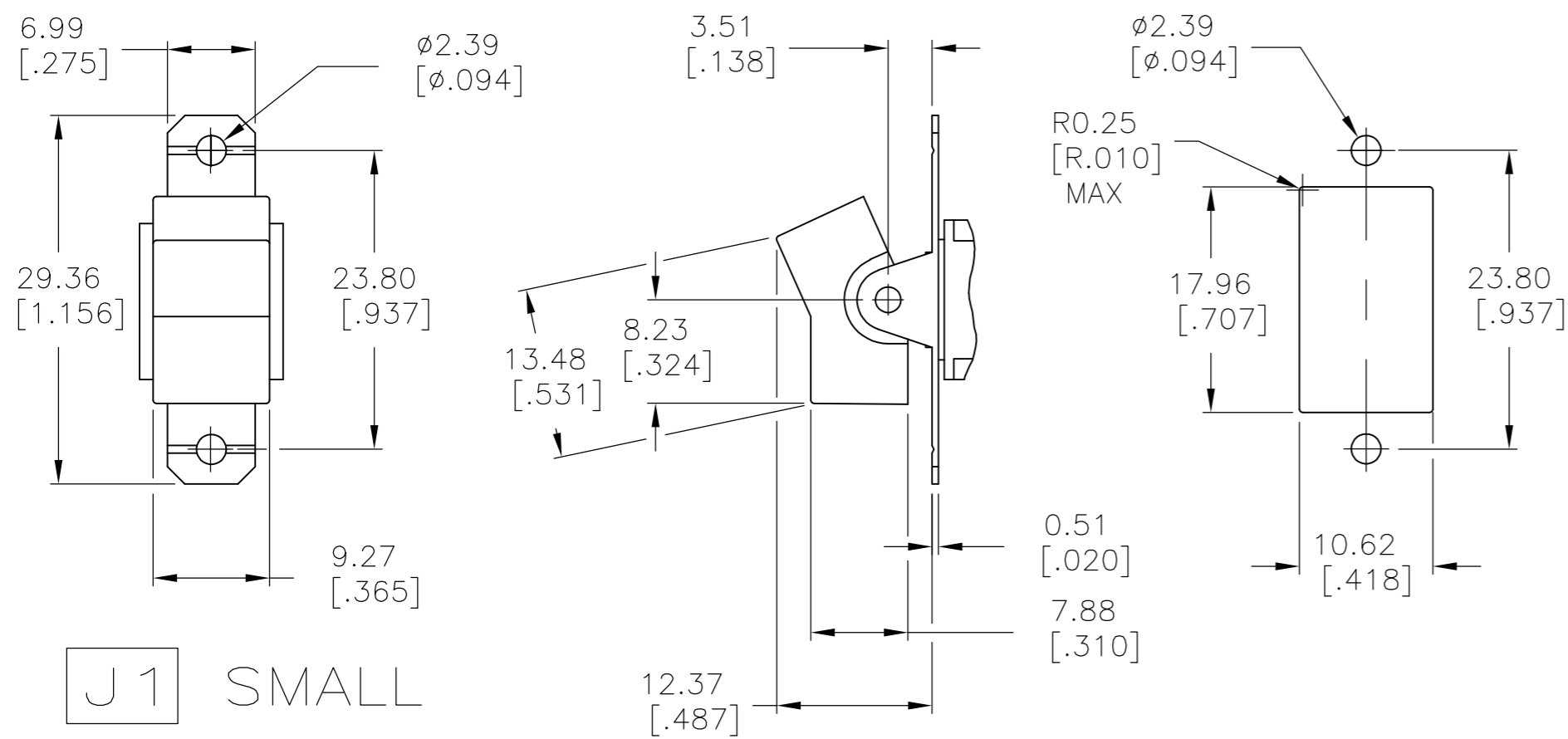

1.52-3.17 [.060-.125]	15.75-15.87 [.620-.625]
1.19-1.50 [.047-.059]	15.72 [.619]
PANEL THICKNESS	DIM "A"

THIS DRAWING IS A CONTROLLED DOCUMENT.		DWN	M.BINNER	06JAN05	 TE Connectivity
DIMENSIONS: mm [INCHES]		CHK	M.ZITTO	06JAN05	
TOLERANCES UNLESS OTHERWISE SPECIFIED:		APVD	M.ZITTO	06JAN05	
0 PLC ± - 1 PLC ± - 2 PLC ± - 3 PLC ± .010 4 PLC ± - ANGLES ± 4°		PRODUCT SPEC	NAME		
MATERIAL	FINISH	APPLICATION SPEC	GEMINI A SERIES ROCKER SWITCH DOUBLE POLE		RESTRICTED TO
CUSTOMER DRAWING		WEIGHT	-	SIZE	A2
SCALE		CAGE CODE		DRAWING NO	00779
SHEET		C=1571987		REV	A6

THIS DRAWING IS UNPUBLISHED. RELEASED FOR PUBLICATION
 © COPYRIGHT - By - ALL RIGHTS RESERVED.

LOC		DIST		REVISIONS			
P	LTR	DESCRIPTION	DATE	DWN	APVD		
AD	00	SEE SHEET 1					

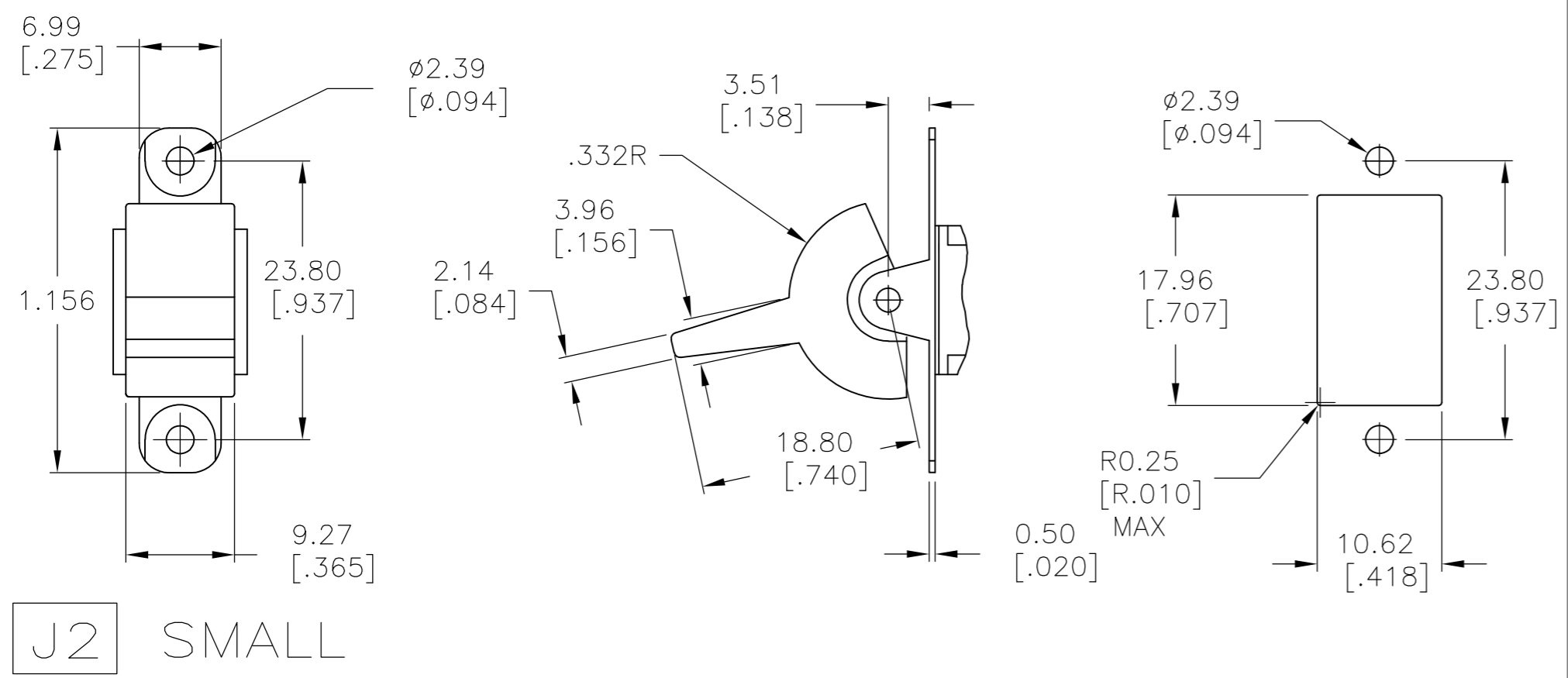

J2 SMALL

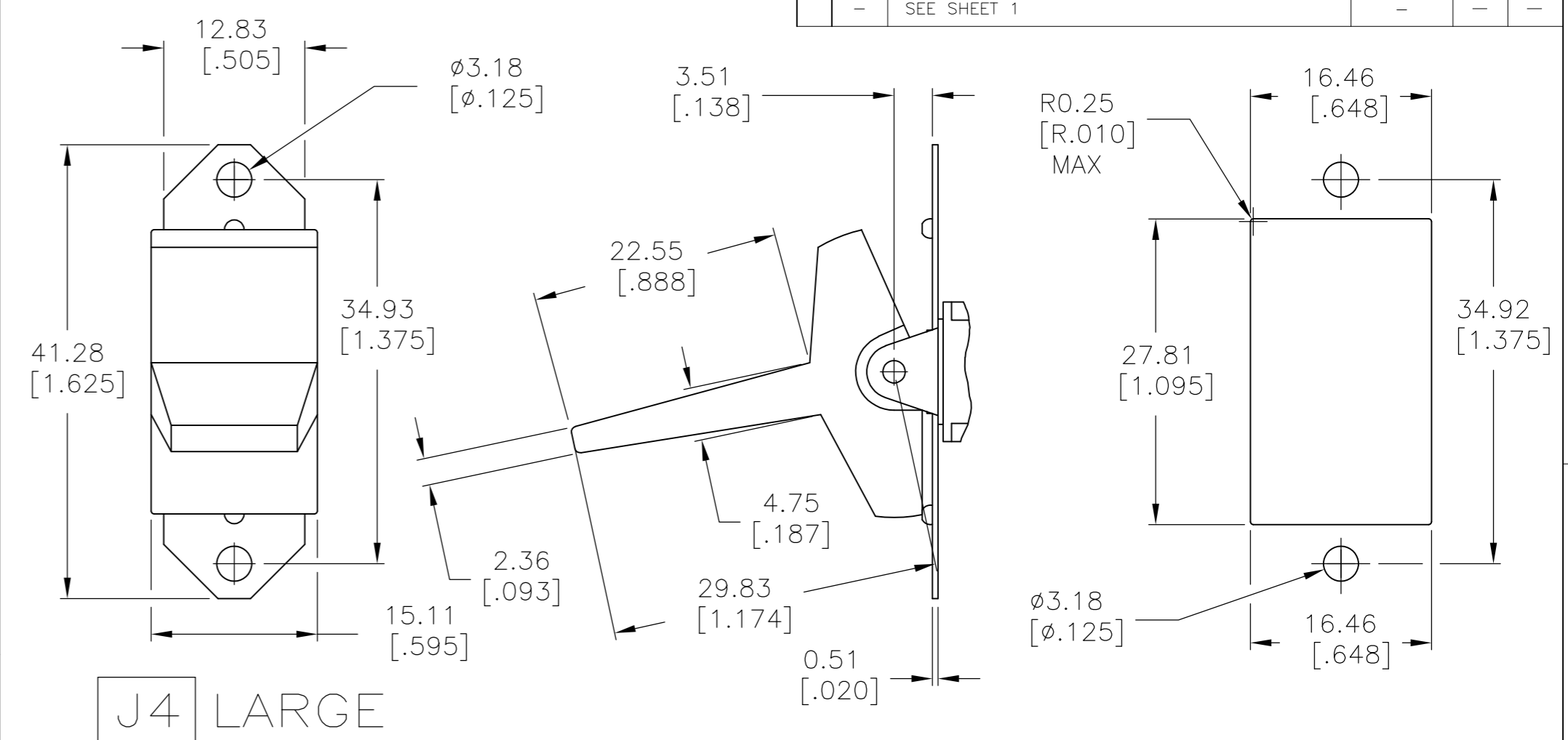

J4 LARGE

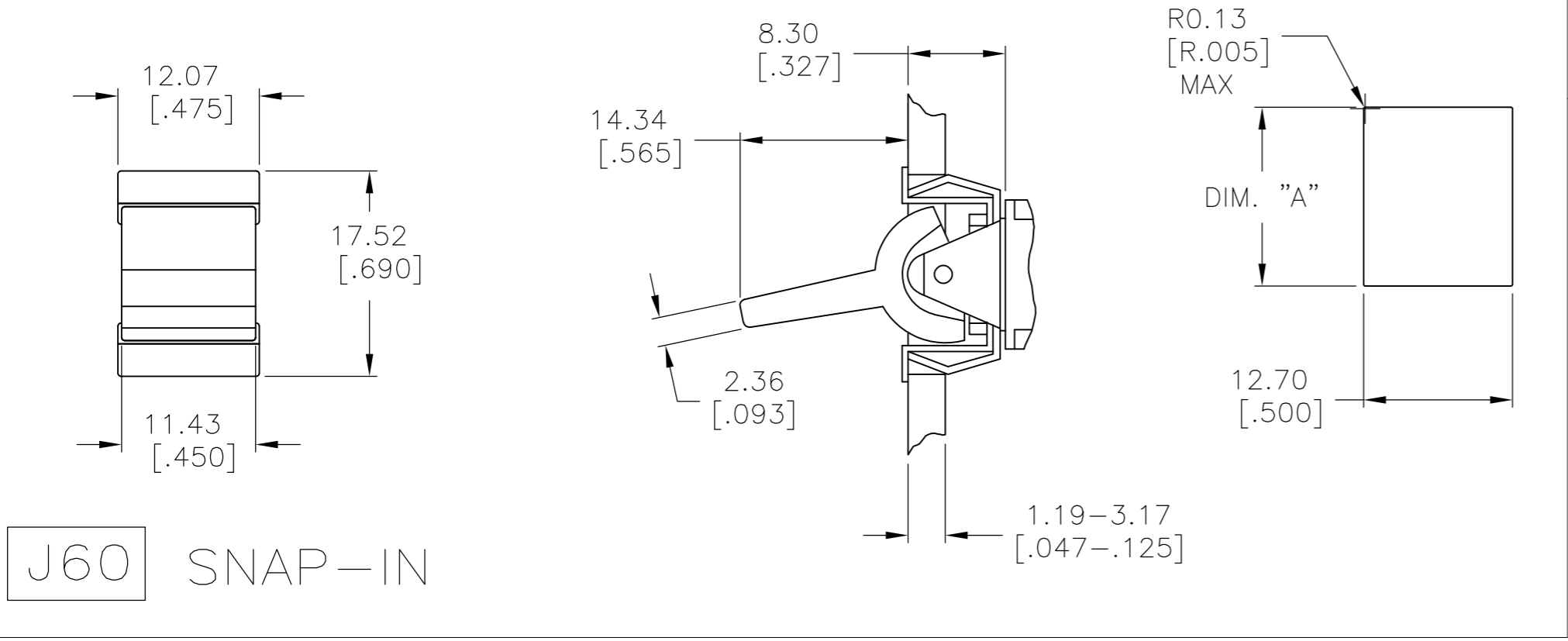

J60 SNAP-IN

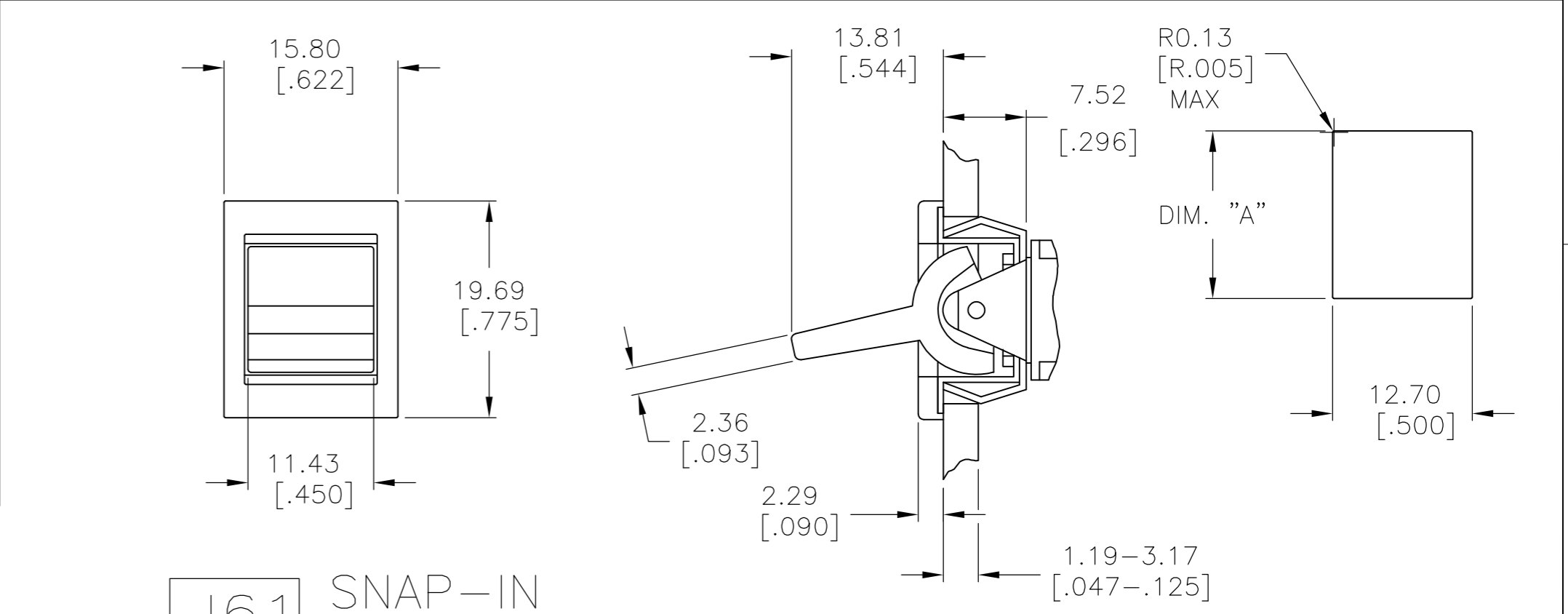

J61 SNAP-IN WITH BEZEL

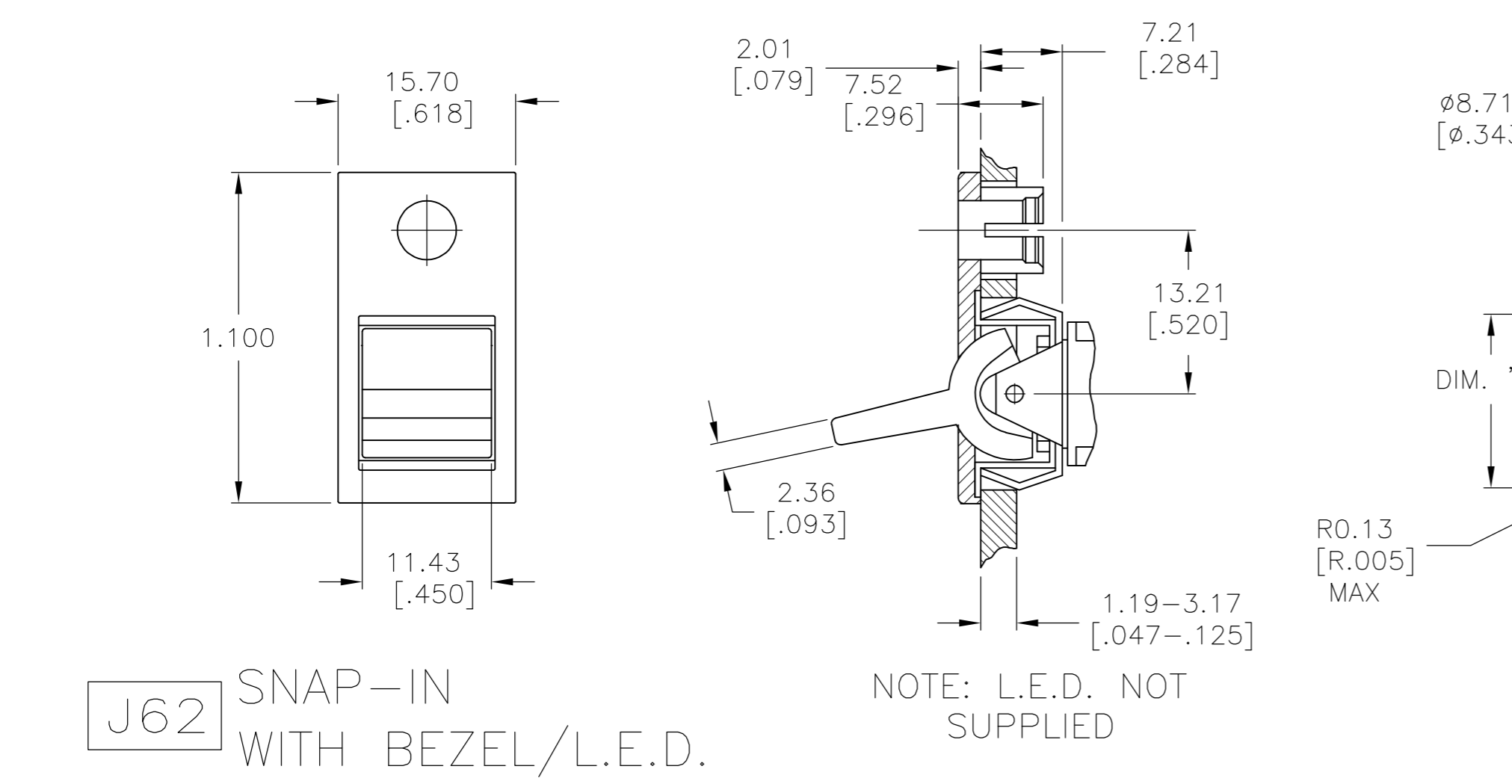

J62 SNAP-IN WITH BEZEL/L.E.D.

NOTE: L.E.D. NOT SUPPLIED

1.52-3.17 [0.060-.125]	15.75-15.87 [0.620-.625]
1.19-1.50 [0.047-.059]	15.72 [0.619]
PANEL THICKNESS	
DIM "A"	

THIS DRAWING IS A CONTROLLED DOCUMENT.		DWN	M.BINNER	06JAN05		TE Connectivity	
DIMENSIONS: mm [INCHES]		CHK	M.ZITTO	06JAN05		NAME	
TOLERANCES UNLESS OTHERWISE SPECIFIED:		APVD	M.ZITTO	06JAN05	GEMINI A SERIES ROCKER SWITCH		
0 PLC	± -	PRODUCT SPEC	APPLICATION SPEC			DOUBLE POLE	
1 PLC	± -	WEIGHT			SIZE	CAGE CODE	DRAWING NO
2 PLC	± -	MATERIAL			A2	00779	1571987
3 PLC	± .010	FINISH			RESTRICTED TO		
4 PLC	± -	CUSTOMER DRAWING			SCALE	SHEET	REV
ANGLES	± 4°	SCALE			2:1	3 OF 5	A6

THIS DRAWING IS UNPUBLISHED. RELEASED FOR PUBLICATION
 © COPYRIGHT - By - ALL RIGHTS RESERVED.

LOC		DIST		REVISIONS			
P	LTR	DESCRIPTION	DATE	DWN	APVD		
AD	00	SEE SHEET 1	-	-	-		

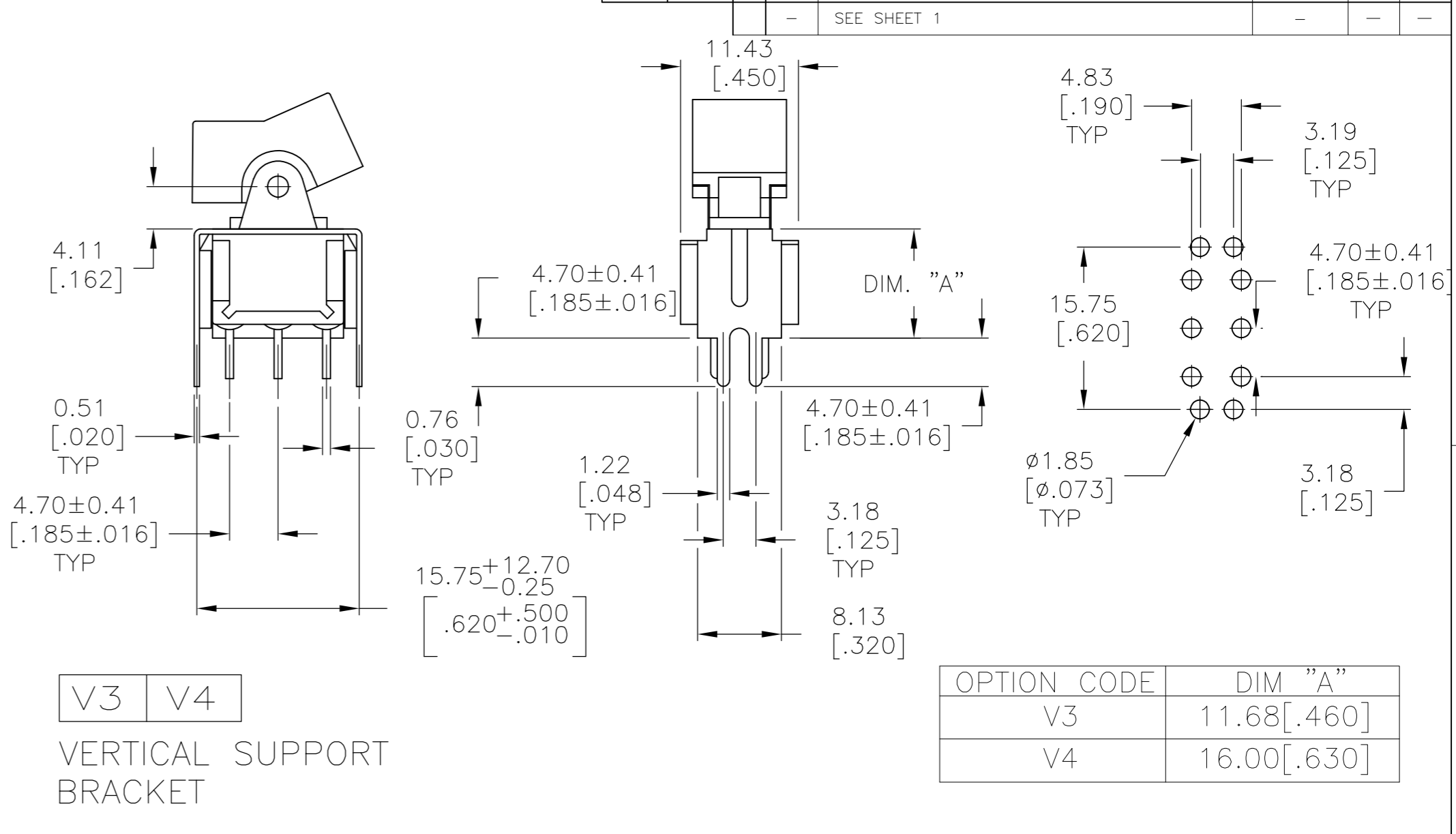
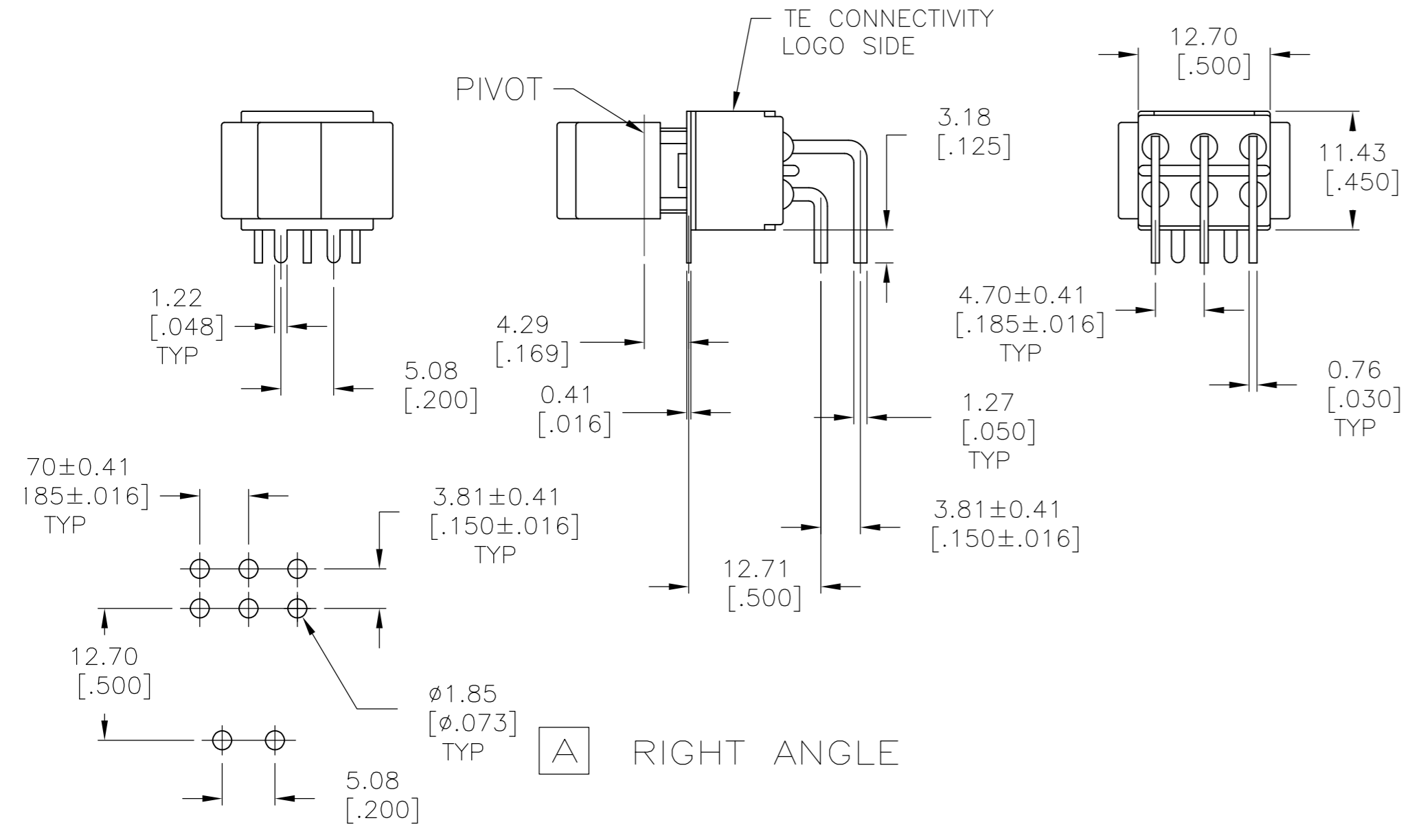

OPTION CODE	DIM "A"
V3	11.68[.460]
V4	16.00[.630]

OPTION CODE	DIM "A"
V6	11.68[.460]
V7	16.00[.630]

AV2 VERTICAL RIGHT ANGLE

THIS DRAWING IS A CONTROLLED DOCUMENT.

DWN	M.BINNER	06JAN05		TE Connectivity		
CHK	M.ZITTO	06JAN05				
APVD	M.ZITTO	06JAN05				
PRODUCT SPEC						
APPLICATION SPEC			NAME			
MATERIAL			GEMINI A SERIES ROCKER SWITCH DOUBLE POLE			
FINISH			SIZE	CAGE CODE	DRAWING NO	RESTRICTED TO
			A2	00779	C=1571987	-
CUSTOMER DRAWING			SCALE	SHEET	REV	
			2:1	4 OF 5	A6	

THIS DRAWING IS UNPUBLISHED. RELEASED FOR PUBLICATION
 © COPYRIGHT - By - ALL RIGHTS RESERVED.

LOC		DIST		REVISIONS			
P	LTR	DESCRIPTION	DATE	DWN	APVD		
-	-	SEE SHEET 1	-	-	-		

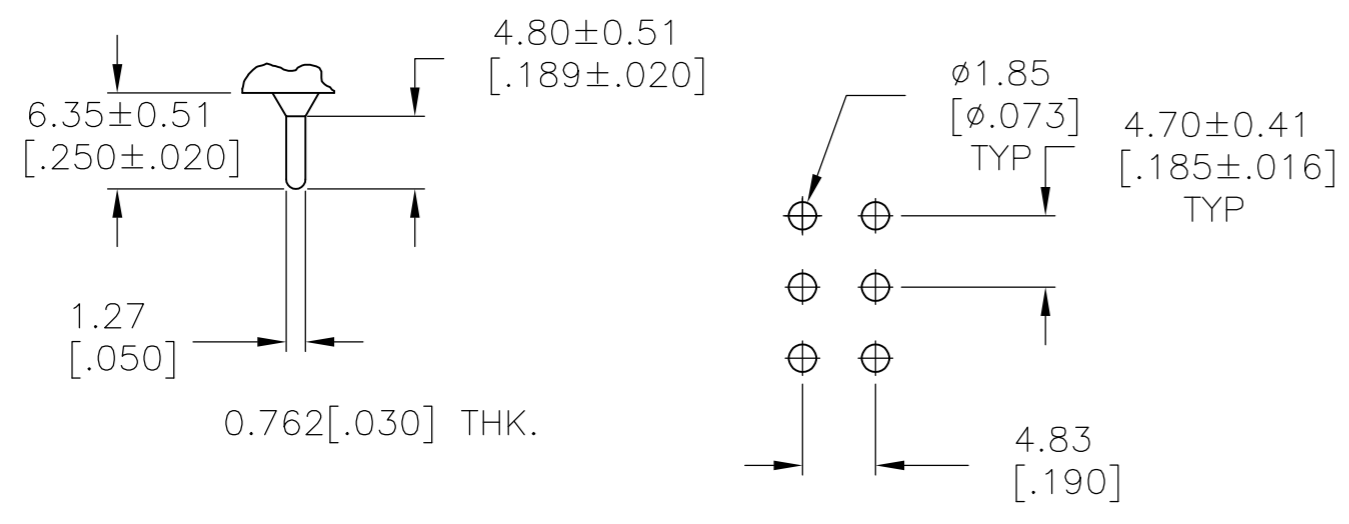

C PRINTED CIRCUIT

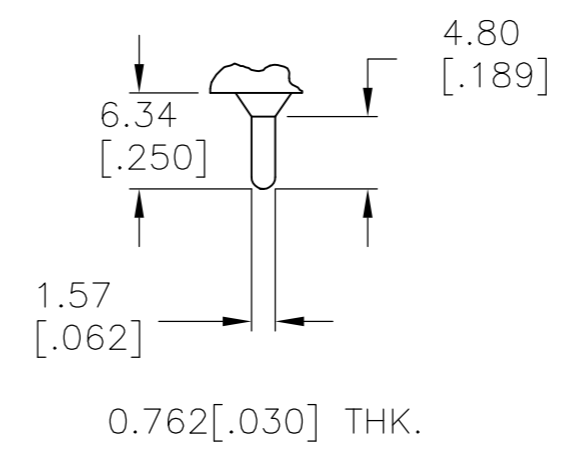

Z3 QUICK CONNECT

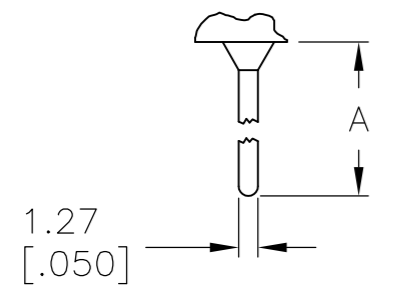

OPTION	DIM A
W	18.69[.736]
W4	26.97[1.062]

0.762[.030] THK.

W **W4** WIRE WRAP

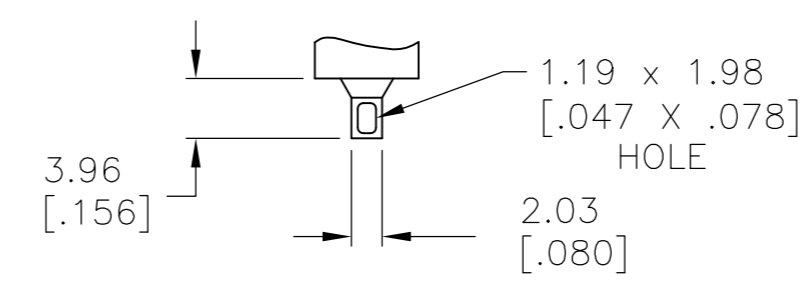

Z WIRE LUG

A213J61ZQ0004	4-1571987-4
A211J51ZQ0004	4-1571987-3
A208J61ZQ0004	4-1571987-2
A208J51ZQ0004	4-1571987-1
A208J1V3Q0004	4-1571987-0
NOT ASSIGNED	3-1571987-9
A207J61ZQ0004	3-1571987-8
A207J51ZQ0004	3-1571987-7
A207J3ZQ0004	3-1571987-6
A207J1ZQ0004	3-1571987-5
A205J61ZQ0004	3-1571987-4
A205J51ZQ0004	3-1571987-3
A205J2ZQ0004	3-1571987-2
A205J2CQ0004	3-1571987-1
A205J1ZQ0004	3-1571987-0
A205J1AV2Q0004	2-1571987-9
NOT ASSIGNED	2-1571987-8
A203J61ZQ0004	2-1571987-7
A203J51ZQ0004	2-1571987-6
NOT ASSIGNED	2-1571987-5
A203J1ZQ0004	2-1571987-4
NOT ASSIGNED	2-1571987-3
A203J1CQ204	2-1571987-2
A203J1AV2Q004	2-1571987-1
A203J1AQ004	2-1571987-0
A201J61ZQ0004	1-1571987-9
A201J61Z3Q0004	1-1571987-8
A201J51ZQ9904	1-1571987-7
NOT ASSIGNED	1-1571987-6
A201J51ZQ0004	1-1571987-5
A201J50ZQ004	1-1571987-4
A201J50AV2Q804	1-1571987-3
A201J50AV2Q004	1-1571987-2
A201J3ZQ004	1-1571987-1
A201J3ZB004	1-1571987-0
A201J2ZQ004	1571987-9
A201J2CQ004	1571987-8
A201J1ZQ004	1571987-7
A201J1V3Q004	1571987-6
A201J1CQ004	1571987-5
A201J1AV2Q004	1571987-4
A201J1AQ204	1571987-3
A201J1AQ004	1571987-2
A211J61Z3Q0004	1571987-1
ALCO P/N	P/N

MATERIALS CHART		
COMPONENT NAME	BASE MATERIAL	FINISH
CASE	DAP, RED, UL94 V-0	
FRAME	STAINLESS STEEL	
B TERMINALS & CONTACTS	COPPER	GOLD OVER NICKEL
G TERMINALS & CONTACTS	COPPER	GOLD OVER SILVER
Q TERMINALS & CONTACTS	COPPER	SILVER
ACTUATOR	PHENOLIC, BLACK, UL94 V-1	
ROCKER CAP	NYLON, BLACK, UL94 V-1	
BUSHING & ACTUATOR LEVER	ZINC ALLOY	NICKEL
SPRING	MUSIC WIRE	
SUPPORT BRACKET	BRASS	TIN
PIVOT PIN	STEEL	NICKEL
TERMINAL SEAL	EPOXY, UL94 V-1	

THIS DRAWING IS A CONTROLLED DOCUMENT.		DWN M.BINNER 06JAN05																				
DIMENSIONS: mm [INCHES]		CHK M.ZITTO 06JAN05																				
TOLERANCES UNLESS OTHERWISE SPECIFIED:		APVD M.ZITTO 06JAN05	NAME GEMINI A SERIES ROCKER SWITCH DOUBLE POLE																			
<table border="1"> <tr><td>0 PLC</td><td>±</td><td>-</td></tr> <tr><td>1 PLC</td><td>±</td><td>-</td></tr> <tr><td>2 PLC</td><td>±</td><td>-</td></tr> <tr><td>3 PLC</td><td>±</td><td>.010</td></tr> <tr><td>4 PLC</td><td>±</td><td>-</td></tr> <tr><td>ANGLES</td><td>±</td><td>4°</td></tr> </table>		0 PLC	±	-	1 PLC	±	-	2 PLC	±	-	3 PLC	±	.010	4 PLC	±	-	ANGLES	±	4°	PRODUCT SPEC -	SIZE A2	CAGE CODE 00779
0 PLC	±	-																				
1 PLC	±	-																				
2 PLC	±	-																				
3 PLC	±	.010																				
4 PLC	±	-																				
ANGLES	±	4°																				
MATERIAL -		FINISH -	WEIGHT -	DRAWING NO 1571987																		
CUSTOMER DRAWING			RESTRICTED TO -	SCALE 2:1																		
			SHEET 5 of 5	REV A6																		



Компания «ЭлектроПласт» предлагает заключение долгосрочных отношений при поставках импортных электронных компонентов на взаимовыгодных условиях!

Наши преимущества:

- Оперативные поставки широкого спектра электронных компонентов отечественного и импортного производства напрямую от производителей и с крупнейших мировых складов;
- Поставка более 17-ти миллионов наименований электронных компонентов;
- Поставка сложных, дефицитных, либо снятых с производства позиций;
- Оперативные сроки поставки под заказ (от 5 рабочих дней);
- Экспресс доставка в любую точку России;
- Техническая поддержка проекта, помощь в подборе аналогов, поставка прототипов;
- Система менеджмента качества сертифицирована по Международному стандарту ISO 9001;
- Лицензия ФСБ на осуществление работ с использованием сведений, составляющих государственную тайну;
- Поставка специализированных компонентов (Xilinx, Altera, Analog Devices, Intersil, Interpoint, Microsemi, Aeroflex, Peregrine, Syfer, Eurofarad, Texas Instrument, Miteq, Cobham, E2V, MA-COM, Hittite, Mini-Circuits, General Dynamics и др.);

Помимо этого, одним из направлений компании «ЭлектроПласт» является направление «Источники питания». Мы предлагаем Вам помощь Конструкторского отдела:

- Подбор оптимального решения, техническое обоснование при выборе компонента;
- Подбор аналогов;
- Консультации по применению компонента;
- Поставка образцов и прототипов;
- Техническая поддержка проекта;
- Защита от снятия компонента с производства.



Как с нами связаться

Телефон: 8 (812) 309 58 32 (многоканальный)

Факс: 8 (812) 320-02-42

Электронная почта: org@eplast1.ru

Адрес: 198099, г. Санкт-Петербург, ул. Калинина, дом 2, корпус 4, литера А.