

REVISIONS				
ZONE	REV.	DESCRIPTION	DATE	APPROVED
ALL	A	TABLE REDRAWN ECO 3290	12/10/86	
	B	REMOVED UNUSED P/N#	02/10/09	
	C	ADDED TS209N	03/04/11	
	D	ADDED TS-425	09/13/12	

DETAIL 1

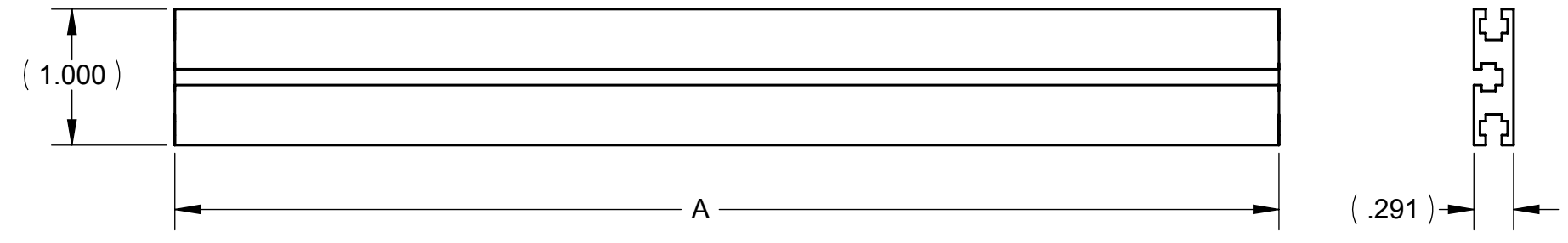

DETAIL 2

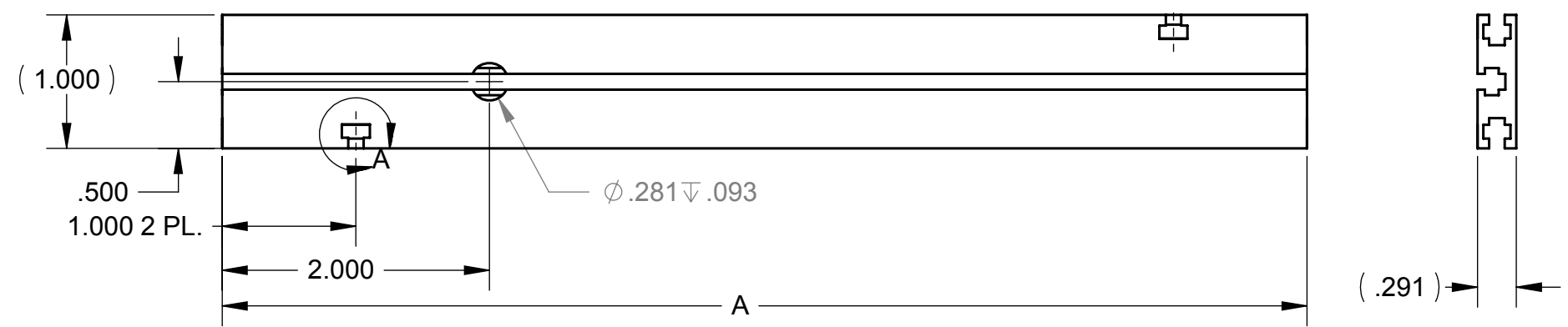

DETAIL 3

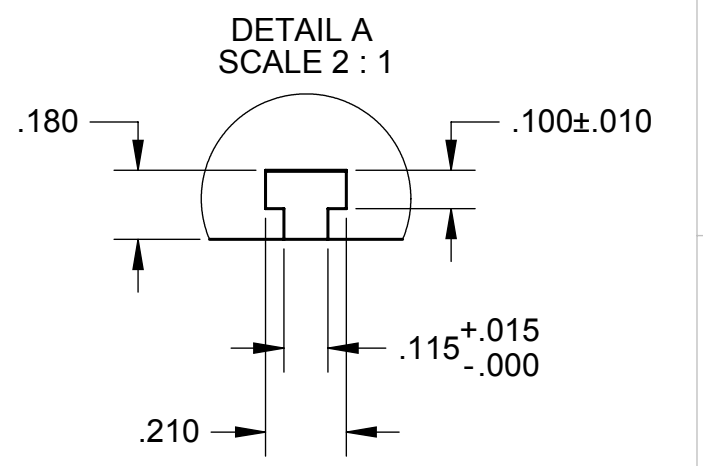
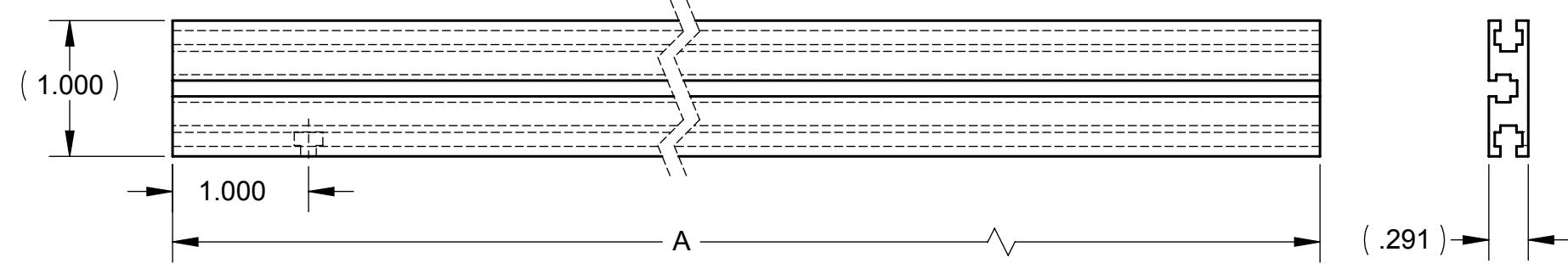

PART NO.	"A" DIM.	DETAIL NO.
TS81	8.120	2
TS169	16.850	2
TS209	20.850	2
TS300	30.00 +1.50/-0.00	1
TS600	60.00 +1.50/-0.00	1
TS169-3	16.850	3
TS209N	20.850	1
TS180	18.000	1
TS190	19.000	2
TS195	19.500	2
TS195-0	19.500	1
TS170	17.000	2
TS-425	4.125	2

- 5. DEGREASE
- 4. STRAIGHT WITHIN .015/10" IN LENGTH
- 3. CUT ENDS TO BE SQUARE WITHIN .0025/INCH IN WIDTH
- 2. REMOVE ALL BURRS
- 1. MAT'L: AL. EXTRUSION, 6063-T6, PRE-ANOD., P/N TS100

NOTES: UNLESS OTHERWISE SPECIFIED.

PROPRIETARY AND CONFIDENTIAL
 THE INFORMATION CONTAINED IN THIS DRAWING IS THE SOLE PROPERTY OF VECTOR ELECTRONICS & TECH., INC. ANY REPRODUCTION IN PART OR AS A WHOLE WITHOUT THE WRITTEN PERMISSION OF VECTOR ELECTRONICS & TECH., INC. IS PROHIBITED.

UNLESS OTHERWISE SPECIFIED:
 DIMENSIONS ARE IN INCHES
 TOLERANCES:
 FRACTIONAL ±
 ANGULAR: ±1°
 TWO PLACE DECIMAL ±.03
 THREE PLACE DECIMAL ±.010
 INTERPRET GEOMETRIC TOLERANCING PER:
 MATERIAL **1**
 FINISH
 DO NOT SCALE DRAWING

	NAME	DATE
DRAWN	TRUSHAR	02/06/09
CHECKED		
ENG APPR.		
MFG APPR.		
Q.A.		

THIRD ANGLE PROJECTION

VECTOR 11115 VANOWEN ST., NORTH HOLLYWOOD, CA 91605
 ELECTRONICS & TECHNOLOGY, INC.

T-STRUT W/O INSERTS

SIZE	DWG. NO.	REV
B	5280006	D
SCALE: 1:1	WEIGHT:	SHEET 1 OF 1

INSPECTION REQUIREMENTS	
1	CHECK OVERALL LENGTH
2	CHECK "C" DIMENSION
3	VERIFY .156 DIA. WILL FIT INTO PUNCHED RADII & .160 DIA. WILL NOT FIT INTO PUNCHED RADII
4	CHECK "B" DIMENSION
5	NO CHIPS IN THE BOTTOM OF SLOT

REVISIONS				
ZONE	REV.	DESCRIPTION	DATE	APPROVED
ALL	-	RELEASED FOR PROTOTYPE 100 UNITS OF CCK13S 50 CCM14S & 50 CCK13S	02/14/80	
	A1	P/N TS81-5 NO. OF HOLES WAS 30 ACTUAL STOCK PARTS HAVE 31	07/31/80	
	B	P/N TS81-5 "B" DIM. WAS 7.500 NO. OF HOLES WERE 31/ ECO2013	03/26/81	
	C	MOVED 1.000 DIM. LOCATION CALLOUT FOR CLARITY NO ECO		
	D	ADDED TS81-6 & -7		
	D	INC ECO 2628	12/17/84	
	E	INC ECO 3924		
	F	REMOVED P/N# TS81-6, -7 TS169-5, TS209-5	02/10/09	
	G	ADDED P/N TS169-5/90	02/13/13	

D

C

B

A

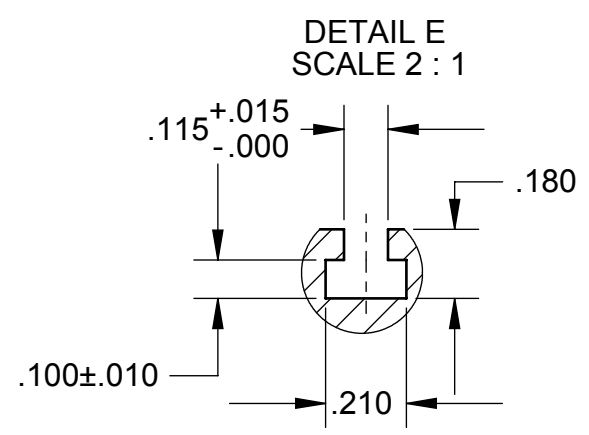
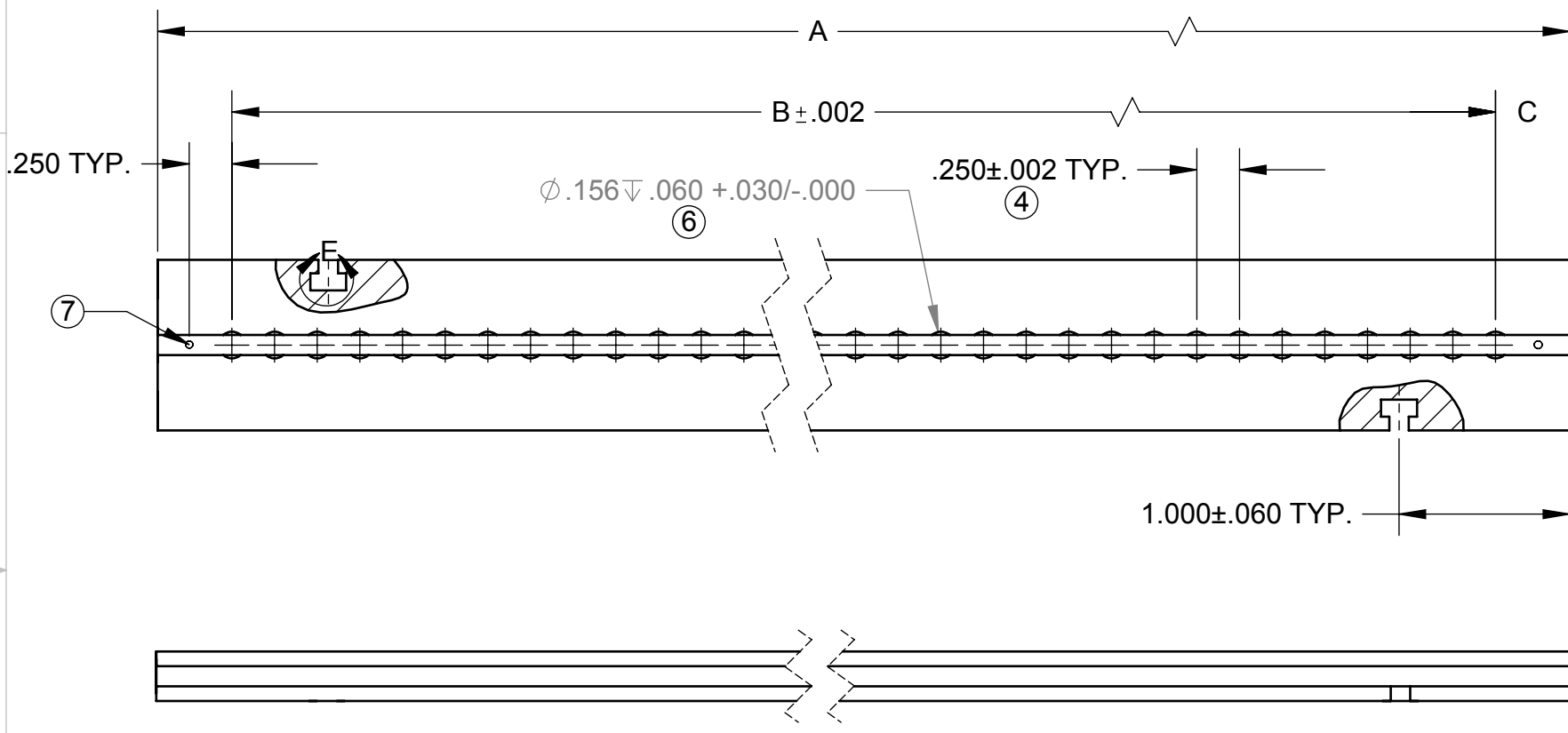

PART NO.	A	B	C	NO. OF HOLES
TS81-5/90	8.120	7.250	.435	30
TS169-6/90	16.850	15.750	.675	64
TS169-5/90	16.850	15.750	.550	64

- ⑦ TOOLING MARK MAY APPEAR
- ⑥ USE .1565 DIA. PUNCH TO FORM RADIUS EQUAL WITHIN ±.005 FROM \bar{C} OF SLOT
- 5. PART TO BE FREE OF BURRS AND SURFACE SCRATCHES
- ④ NON CUMULATIVE TOLERANCE
- 3. PART TO BE STRAIGHT WITHIN .015/10 INCHES IN LENGTH
- 2. CUT ENDS TO BE SQUARE WITHIN .0025/INCH IN WIDTH
- 1. MAT'L: AL. EXTRUSION, 6063-T6, PRE-ANOD., P/N TS100

NOTES: UNLESS OTHERWISE SPECIFIED.

PROPRIETARY AND CONFIDENTIAL
THE INFORMATION CONTAINED IN THIS DRAWING IS THE SOLE PROPERTY OF VECTOR ELECTRONICS & TECH., INC. ANY REPRODUCTION IN PART OR AS A WHOLE WITHOUT THE WRITTEN PERMISSION OF VECTOR ELECTRONICS & TECH., INC. IS PROHIBITED.

UNLESS OTHERWISE SPECIFIED:	NAME	DATE
DIMENSIONS ARE IN INCHES	DRAWN	TRUSHAR
TOLERANCES:	CHECKED	02/10/09
FRACTIONAL ±	ENG APPR.	
ANGULAR: ± X°	MFG APPR.	
TWO PLACE DECIMAL ±.03	Q.A.	
THREE PLACE DECIMAL ±.005		
INTERPRET GEOMETRIC TOLERANCING PER:		
MATERIAL 1	THIRD ANGLE PROJECTION	
FINISH <input type="checkbox"/>		
DO NOT SCALE DRAWING		

VECTOR 11115 VANOWEN ST., NORTH HOLLYWOOD, CA 91605

T-STRUT FOR SNAP-IN CARD GUIDE

SIZE	DWG. NO.	REV
B	M6336D4.2	G
SCALE: 1:1	WEIGHT:	SHEET 1 OF 1



Компания «ЭлектроПласт» предлагает заключение долгосрочных отношений при поставках импортных электронных компонентов на взаимовыгодных условиях!

Наши преимущества:

- Оперативные поставки широкого спектра электронных компонентов отечественного и импортного производства напрямую от производителей и с крупнейших мировых складов;
- Поставка более 17-ти миллионов наименований электронных компонентов;
- Поставка сложных, дефицитных, либо снятых с производства позиций;
- Оперативные сроки поставки под заказ (от 5 рабочих дней);
- Экспресс доставка в любую точку России;
- Техническая поддержка проекта, помощь в подборе аналогов, поставка прототипов;
- Система менеджмента качества сертифицирована по Международному стандарту ISO 9001;
- Лицензия ФСБ на осуществление работ с использованием сведений, составляющих государственную тайну;
- Поставка специализированных компонентов (Xilinx, Altera, Analog Devices, Intersil, Interpoint, Microsemi, Aeroflex, Peregrine, Syfer, Eurofarad, Texas Instrument, Miteq, Cobham, E2V, MA-COM, Hittite, Mini-Circuits, General Dynamics и др.);

Помимо этого, одним из направлений компании «ЭлектроПласт» является направление «Источники питания». Мы предлагаем Вам помощь Конструкторского отдела:

- Подбор оптимального решения, техническое обоснование при выборе компонента;
- Подбор аналогов;
- Консультации по применению компонента;
- Поставка образцов и прототипов;
- Техническая поддержка проекта;
- Защита от снятия компонента с производства.



Как с нами связаться

Телефон: 8 (812) 309 58 32 (многоканальный)

Факс: 8 (812) 320-02-42

Электронная почта: org@eplast1.ru

Адрес: 198099, г. Санкт-Петербург, ул. Калинина, дом 2, корпус 4, литера А.