

IB IL TEMP 4/8 RTD/EF ...

Inline terminal with eight analog input channels for the connection of resistive temperature detectors (RTD)



Data sheet
7567_en_07

© PHOENIX CONTACT 2012-07-07

1 Function description

The terminal is designed for use within an Inline station. This terminal provides an 8-channel input module with three linear resistance ranges for resistance temperature detectors.

This terminal supports, for example:

- Platinum and nickel sensors, e.g., Pt100, Pt1000, Ni100, and Ni1000 according to the DIN IEC 60751 standard and to the SAMA RC 21-4-1966 guideline
- KTY81 and KTY84 sensors
- Cu10, Cu50, and Cu53 sensors

Communication either via

- Parameter channel (PCP), all eight measuring channels, or
- Four process data words; always four channels (four 16-bit values) using the multiplex method

Features

- Connection of eight RTD temperature sensors and linear resistors in 4-wire technology
- High precision and noise immunity
- Temperature stability

- High-resolution temperature and resistance measurement
- Resistance values (R_0) can be preset separately using configuration bits
- Channels are configured independently of one another using the bus system
- Configuring the open circuit detection sensitivity (firmware 1.10 or later)
- Additional representation in float format according to IEEE 754
- Diagnostic and status indicators
- Channel scout functionality, e.g., for optical channel identification during startup
- **IB IL TEMP 4/8 RTD/EF-PAC,**
IB IL TEMP 4/8 RTD/EF:
Hardware version 02 or later:
IB IL TEMP 4/8 RTD/EF 2MBD-PAC
Hardware version 01 or later:
Approved for use in zone 2 potentially explosive areas (observe the notes on page 12)



This data sheet only is valid in connection with the IL SYS INST UM E user manual (see "Documentation" on page 3).



Make sure you always use the latest documentation. It can be downloaded at www.phoenixcontact.net/catalog.



This data sheet is valid for all products listed on page 3.

Table of contents

| | | |
|----|---------------------------------------------------------------------------|----|
| 1 | Function description | 1 |
| 2 | Ordering data..... | 3 |
| 3 | Technical data | 4 |
| 4 | Internal circuit diagram..... | 9 |
| 5 | Local diagnostic and status indicators and terminal point assignment..... | 10 |
| 6 | Safety notes..... | 10 |
| 7 | Installation instructions | 10 |
| 8 | Electrical isolation | 11 |
| 9 | Connection notes..... | 11 |
| 10 | Notes on using the terminal in potentially explosive areas | 12 |
| 11 | Connection examples | 13 |
| 12 | Programming data/configuration data..... | 14 |
| 13 | Process data..... | 15 |
| 14 | Process data output words OUT | 15 |
| 15 | Process data input words IN | 19 |
| 16 | Formats for representing measured values..... | 20 |
| 17 | PCP communication | 22 |
| 18 | Object descriptions | 22 |
| 19 | Configuration and analog values..... | 27 |
| 20 | Temperature and resistance measuring ranges..... | 27 |
| 21 | Measuring errors due to connection cables | 27 |
| 22 | Calculation examples | 29 |
| 23 | Configuration example..... | 31 |
| 24 | Notes on diagnostic behavior in the event of an error | 33 |

2 Ordering data

Products

| Description | Type | Order No. | Pcs./Pkt. |
|----------------------------------------------------------------------------------------------------------------------------------------------|--------------------------------|-----------|-----------|
| Inline terminal for resistive temperature detectors, without accessories, transmission speed: 500 kbps | IB IL TEMP 4/8 RTD/EF | 2897305 | 1 |
| Inline terminal for resistive temperature detectors, complete with accessories (connectors and labeling fields) transmission speed: 500 kbps | IB IL TEMP 4/8 RTD/EF-PAC | 2897402 | 1 |
| Inline terminal for resistive temperature detectors, complete with accessories (connectors and labeling fields) transmission speed: 2 Mbps | IB IL TEMP 4/8 RTD/EF 2MBD-PAC | 2897606 | 1 |



Four of the connectors listed below are needed for the fitting of the IB IL TEMP 4/8 RTD/EF terminal.

Accessories: Connectors

| Description | Type | Order No. | Pcs./Pkt. |
|-----------------------------------------|-------------------------|-----------|-----------|
| Inline connector, with color print | IB IL SCN-8-GY-CP | 2861179 | 10 |
| Inline connector with shield connection | IB IL SCN-6 SHIELD-TWIN | 2740245 | 5 |

Accessories: Other

| Description | Type | Order No. | Pcs./Pkt. |
|--------------------------------------------------------------------------------------------------------------------------------------------------------------------------|-------------|-----------|-----------|
| Shield connection clamp for applying the shield on busbars, contact resistance < 1 mOhm | | | |
| 8 mm diameter | SK8 | 3025163 | 10 |
| 14 mm diameter | SK14 | 3025176 | 10 |
| 20 mm diameter | SK20 | 3025189 | 10 |
| 35 mm diameter | SK35 | 3026463 | 10 |
| Support, Length: 77.35 mm, Width: 6.2 mm, Color: gray | AB-SK | 3025341 | 10 |
| Support, Length: 95.5 mm, Width: 6.2 mm, Color: gray | AB-SK 65 | 3026489 | 10 |
| Support, Length: 10 mm, Width: 56 mm, Height: 20 mm, Color: silver | AB-SK/E | 3026476 | 10 |
| Neutral busbar, Width: 10 mm, Height: 3 mm, Length: 1000 mm, Color: silver | NLS-CU 3/10 | 0402174 | 10 |
| Power terminal block, Connection method Screw connection, Load current : 41 A, Cross section: 0.5 mm ² - 6 mm ² , Width: 7 mm, Color: silver | AK 4 | 0404017 | 50 |
| Power terminal block, Connection method?Screw connection, Load current : 41 A, Cross section: 0.5 mm ² - 6 mm ² , Width: 7 mm, Color: green-yellow | AK G GNYE | 0421029 | 50 |
| Power terminal block, Connection method?Screw connection, Load current : 41 A, Cross section: 0.5 mm ² - 6 mm ² , Width: 7 mm, Color: black | AKG 4 BK | 0421032 | 50 |

Documentation

| Description | Type | Order No. | Pcs./Pkt. |
|-----------------------------------------------------------------------------------|--------------------|-----------|-----------|
| "Automation terminals of the Inline product range" user manual | IL SYS INST UM E | - | - |
| "Inline terminals for use in zone 2 potentially explosive areas" application note | AH EN IL EX ZONE 2 | - | - |

3 Technical data

General data

| | |
|--------------------------------------------------------|------------------------------------------------------------------------------|
| Housing dimensions (width x height x depth) | 48.8 mm x 120 mm x 72 mm |
| Weight | 126 g without connectors; 190 g with connectors |
| Operating mode | Process data mode with 5 words/1 PCP word |
| Connection method for sensors | 4-wire technology |
| Permissible ambient temperature (operation) | |
| At 500 kbps | -25°C to +60°C |
| At 2 Mbps | -25°C to +55°C |
| Permissible ambient temperature (storage/transport) | -25°C to +85°C |
| Permissible humidity (operation/storage/transport) | 10% to 95% according to DIN EN 61131-2 |
| Permissible air pressure (operation/storage/transport) | 70 kPa to 106 kPa (up to 3000 m above sea level) |
| Degree of protection according to IEC 60529 | IP20 |
| Class of protection | III, EN 61131-2, IEC 61131-2 |
| Connection data for Inline connectors | |
| Connection method | Spring-cage terminals |
| Conductor cross-section | 0.08 mm ² to 1.5 mm ² (solid or stranded), 28 - 16 AWG |

Interface

| | |
|-----------|--------------|
| Local bus | Data routing |
|-----------|--------------|

Transmission speed

| | |
|--------------------------------------------------|----------|
| IB IL TEMP 4/8 RTD/EF, IB IL TEMP 4/8 RTD/EF-PAC | 500 kbps |
| IB IL TEMP 4/8 RTD/EF 2MBD-PAC | 2 Mbps |

Power consumption

| | 500 kbps | 2 Mbps |
|------------------------------------------|----------|---------|
| Communications power U_L | 7.5 V | 7.5 V |
| Current consumption from U_L , typical | 95 mA | 115 mA |
| I/O supply voltage U_{ANA} | 24 V DC | 24 V DC |
| Current consumption at U_{ANA} | 6.0 mA | 6.0 mA |
| Total power consumption | 0.85 W | 1.01 W |

Supply of the module electronics and I/O through the bus coupler/power terminal

| | |
|-------------------|-------------------|
| Connection method | Potential routing |
|-------------------|-------------------|

Analog inputs

| | |
|--------------------------------------------|---------------------------------------------------------------------------------------------|
| Number | Eight inputs (4-wire RTD) for resistive temperature detectors |
| Resolution of the analog/digital converter | 24 bits |
| Measured value representation | 16 bits (IL standard 15 bits + sign bit) |
| Standardized representation for | Degrees Celsius (°C), degrees Fahrenheit (°F) and as linear resistance in Ohms (Ω) |
| Resolution (quantization) | Standardized representation of temperature measurement values |
| In the °C range | 0.1 K/LSB (default setting) 0.01K/LSB |
| In the °F range | 0.1 °F/LSB 0.01 °F/LSB |
| In the linear Ohm range | 0.01 Ω /LSB 0.1 Ω /LSB 1 Ω /LSB |
| Connection of signals | 4-wire, shielded sensor cable (e.g., LiYCY (TP)) |
| Maximum permissible cable length | 250 m (4-wire termination with LiYCY (TP) 2 x 2 x 0.5 mm ²) |

Analog inputs (continued)

Crosstalk attenuation (channel/channel) in the sensor type operating mode:

| | |
|---------------------------------------------|------------------------------------------------------------------------|
| Pt100 (resolution 0.01 K/LSB) | 98.6 dB, typical |
| R _{Lin} 500 (resolution 0.01Ω/LSB) | 100 dB, typical |
| R _{Lin} 5000 (resolution 0.1Ω/LSB) | 88 dB, typical |
| Sensor types that can be used | Pt, Ni, Cu, KTY, linear resistors |
| Characteristics standards | According to DIN EN 60751: 07/1996 / According to SAMA RC 21-4-1966 |
| Process data update | Depending on the filter time |

Scan filter times

| Set filter time | Typical scan time for each measuring channel | Typical scan repeat time for all eight measuring channels |
|------------------|----------------------------------------------|-----------------------------------------------------------|
| 480 ms (default) | 482 ms | 3300 ms |
| 200 ms | 201 ms | 2190 ms |
| 120 ms | 121 ms | 1874 ms |
| 100 ms | 100 ms | 1800 ms |

Differential non-linearity (typical)

In all ranges 1 ppm or ±0.0001%

Integral non-linearity (typical)

In the input ranges

| | |
|-------------------------|-------------------|
| Pt100 | 30 ppm or ±0.003% |
| R _{Lin} 500 Ω | 20 ppm or ±0.002% |
| R _{Lin} 5000 Ω | 200 ppm or ±0.02% |

Supported measuring ranges

| Sensor type | Standard or manufacturer specification | Measuring range | |
|-----------------------------------------------------------|----------------------------------------|-----------------|-------------|
| | | Lower limit | Upper limit |
| Pt sensors (e.g., Pt100, Pt500, Pt1000) | DIN IEC 60751 or SAMA RC 21-4-1966 | -200°C | +850°C |
| Ni sensors (e.g., Ni100, Ni1000) | DIN IEC 60751 or SAMA RC 21-4-1966 | -60°C | +180°C |
| Ni500 (Viessmann) | (Viessmann) | -60°C | +250°C |
| Ni1000 (Landis & Gyr) | (Landis & Gyr) | -50°C | +160°C |
| KTY81-110 | (Philips) | -55°C | +150°C |
| KTY81-210 | (Philips) | -55°C | +150°C |
| KTY84 | (Philips) | -40°C | +300°C |
| Cu10 | SAMA RC 21-4-1966 | -70°C | +500°C |
| Cu50 | SAMA RC 21-4-1966 | -50°C | +200°C |
| Cu53 | SAMA RC 21-4-1966 | -50°C | +180°C |
| Linear resistor R _{Lin} 500 Ω (linear range 1) | | 0 Ω | 525 Ω |
| Linear resistor R _{Lin} 5000 Ω (linear range 2) | | 0 Ω | 5250 Ω |
| Linear resistor R _{Lin} 30000 Ω (linear range 3) | | 0 Ω | 31500 Ω |

Tolerances (typical/maximum) at T_A = +25°C

| Sensor type (4-wire termination) | Measuring range (nominal range) | | Absolute tolerance | | Relative tolerance (of measuring range final value) | |
|----------------------------------|---------------------------------|----------------------|--------------------|---------|-----------------------------------------------------|-----------------------|
| | Lower limit | Upper limit | Typical | Maximum | Typical | Maximum |
| Pt100 | -200°C | +200°C ¹⁾ | ±0.05 K | ±0.19 K | ± 0.03% ²⁾ | ± 0.10% ²⁾ |
| Pt100 | -200°C | +850°C | ±0.09 K | ±0.34 K | ± 0.01% | ± 0.04% |
| Pt1000 | -200°C | +850°C | ±0.29 K | ±0.61 K | ± 0.03% | ± 0.07% |

Tolerances (typical/maximum) at T_A = +25°C (continued)

| Sensor type (4-wire termination) | Measuring range (nominal range) | | Absolute tolerance | | Relative tolerance (of measuring range final value) | |
|------------------------------------------|------------------------------------|-------------|--------------------|----------------|--------------------------------------------------------|---------------------------------------------------|
| | Lower limit | Upper limit | Typical | Maximum | Typical | Maximum |
| Ni100 | -60°C | +180°C | ±0.04 K | ±0.10 K | ± 0.02% | ± 0.05% |
| Ni1000 | -60°C | +180°C | ±0.09 K | ±0.39 K | ± 0.05% | ± 0.22% |
| Ni1000 (Landis & Gyr) | -50°C | +160°C | ±0.09 K | ±0.43 K | ± 0.06% | ± 0.27% |
| KTY81-110 | -55°C | +150°C | ±0.08 K | ±0.34 K | ± 0.06% | ± 0.27% |
| KTY81-210 | -55°C | +150°C | ±0.05 K | – | ± 0.03% | – |
| Linear resistor R _{Lin} 500 Ω | 0 Ω | 500 Ω | ± 0.12 Ω | ± 2.05 Ω | ± 0.02% | ± 0.41% |
| Linear resistor R _{Lin} 5000 Ω | 0 Ω | 5000 Ω | ± 1.50 Ω | ± 10.2 Ω | ± 0.03% | ± 0.20% |
| Linear resistor R _{Lin} 30000 Ω | 0 Ω | 30000 Ω | No information | No information | ± 3% | No data, since this range is not calibrated |



The data contains the offset error, gain error, and linearity error in its respective setting (4-wire technology). See separate table for additional temperature values and possible tolerances under EMI. All errors indicated as a percentage are related to the positive measuring range final value. The data is related to nominal operation (preferred mounting position, U_S = 24 V, etc.) using 4-wire operation for RTD inputs. The maximum tolerance values represent the worst case measurement inaccuracy. They contain the maximum tolerances in the corresponding measuring ranges, which are theoretically possible. The maximum tolerances of calibration and test equipment, which are theoretically possible, have also been taken into consideration. This data is valid for at least 24 months.

- ¹⁾ Specified separately, since the measuring range of ±200°C is used for many applications.
- ²⁾ In the more limited measuring range, the relative tolerance is also related to the measuring range final value of +200°C.

Temperature and drift response at T_A = -25°C to +55°C (+60°C)³⁾

| Sensor type | Measuring range | Typical drift | Maximum drift |
|-------------------------|-------------------|--------------------------------|---------------|
| | | Based on T _A = 25°C | |
| Pt100 sensor | -200°C ... +850°C | 5 ppm/K | 18 ppm/K |
| Pt1000 sensor | -200°C ... +850°C | 20 ppm/K | 65 ppm/K |
| Ni100 sensor | -60°C ... +180°C | 5 ppm/K | 20 ppm/K |
| Ni1000 sensor | -60°C ... +180°C | 20 ppm/K | 65 ppm/K |
| R _{Lin1} range | 0 Ω ... 500 Ω | 8 ppm/K | 20 ppm/K |
| R _{Lin2} range | 0 kΩ ... 5 kΩ | 25 ppm/K | 80 ppm/K |

Absolute tolerance values for the ambient temperature range T_A = -25°C to +55°C (60°C)³⁾

| Sensor type | Measuring range | Typical tolerance | Maximum tolerance |
|----------------------------|-------------------|-------------------|-------------------|
| Pt100 DIN and SAMA sensors | -200°C ... +200°C | ±0.10°C | ±0.37°C |

³⁾ Temperature indication is only valid for Inline terminals with 500 kbps.

| EMI behavior | | | | |
|------------------------------------------------------------------|-------------------------------|------------------------------------------------------|-------------------------------------------------------------|-----------|
| Type of electromagnetic interference | Standard | Level | Additional tolerances of measuring range final value (MRFV) | Criterion |
| Electromagnetic fields | EN 61000-4-3 IEC61000-4-3 | 10 V/m | < 0.1% | A |
| Fast transients (burst) | EN 61000-4-4 IEC61000-4-4 | 1,1 kV | No additional tolerances | A |
| Conducted interference | EN 61000-4-6 IEC 61000-4-6 | 150 kHz ... 80 MHz, 10 V, 80% AM (1 kHz) | No additional tolerances | A |
| Conducted interference (with parameterized ODS = 3, see note) | EN 61000-4-6 IEC 61000-4-6 | 150 kHz ... 300 MHz, 30 V , 80% AM (1 kHz) | No additional tolerances | A |



The values are valid for the default settings of the module (Pt100, resolution 0.1 K/LSB). Even under EMI indicated above is the accuracy class of 0.1 retained.



Additional low tolerances may occur due to the influence of high-frequency electromagnetic interference caused by radio transmission systems in the near vicinity. The values specified refer to nominal operation in the event of direct interference to components without additional shielding such as a steel cabinet, etc.

The above tolerances can be reduced by further shielding the I/O module (e.g., use of a shielded control box/control cabinet, etc.). Please refer to the recommended measures in the IL SYS INST UM E Inline system manual.



Activation of the "open circuit detection sensitivity" (ODS) function is possible with firmware version 1.10 or later. When activating this function, please observe the "Notes on diagnostic behavior in the event of an error" on page 33.

| Common mode rejection with different filter times | | | |
|---------------------------------------------------|-------------|---------------------------------------------------------------|----------------------------------------------------------------------------------------|
| Filter process data encoding | Filter time | Optimization for common mode interference with $F_{interfer}$ | Typical common mode rejection for measuring inputs of analog/digital converters (CMRR) |
| 00 | 480 ms | 50 Hz and 60 Hz | 74 dB |
| 01 | 120 ms | 50 Hz | 80 dB |
| 10 | 101 ms | 60 Hz | 90 dB |
| 11 | 200 ms | 50 Hz and 60 Hz | 69 dB |

Safety equipment

| | |
|----------------------|-----|
| Transient protection | |
| Measuring inputs | Yes |
| Sensor supply | Yes |

Electrical isolation/isolation of the voltage areas

To provide electrical isolation between the logic level and the I/O area, it is necessary to supply the station bus coupler and the sensors connected to the analog input terminal described here from separate power supply units. Interconnection of the power supply units in the 24 V area is not permitted (see also IL SYS INST UM E user manual).

Common potentials

The 24 V main voltage, 24 V segment voltage, and GND have the same potential. FE is a separate potential area.

Separate potentials in the system consisting of bus coupler/power terminal and I/O terminal

| Test distance | Test voltage |
|---------------------------------------------------------------------------|------------------------|
| 5 V supply incoming remote bus/7.5 V supply (bus logic) | 500 V AC, 50 Hz, 1 min |
| 5 V supply outgoing remote bus/7.5 V supply (bus logic) | 500 V AC, 50 Hz, 1 min |
| 7.5 V supply (bus logic), 24 V supply U_{ANA} / I/O | 500 V AC, 50 Hz, 1 min |
| 7.5 V supply (bus logic), 24 V supply U_{ANA} / functional earth ground | 500 V AC, 50 Hz, 1 min |
| I/O / functional earth ground | 500 V AC, 50 Hz, 1 min |

Error messages to the higher-level control or computer system

Failure of the internal, electrically isolated I/O voltage supply Yes, peripheral fault

Failure of or insufficient communications power U_L Yes, peripheral fault

Error messages via process data

Peripheral fault/user error Yes (see Section 16 "Formats for representing measured values")

Approvals

For the latest approvals, please visit www.phoenixcontact.net/catalog.

4 Internal circuit diagram

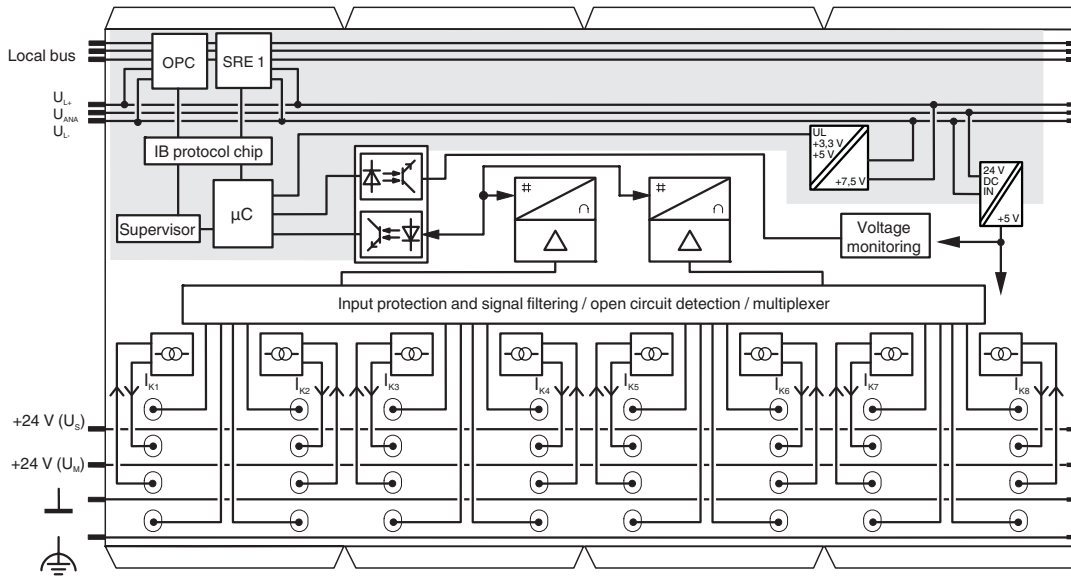

7567B002

Figure 1 Internal wiring of the terminal points

Key:



Protocol chip



Register expansion



Hardware monitoring

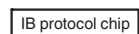

Hardware monitoring



Microcontroller



Optocoupler



Analog/digital converter



Amplifier



Voltage monitoring



DC/DC converter with electrical isolation

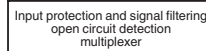

Input protection and signal filter, open circuit detection, multiplexer



Constant current source



Other symbols used are explained in the IL SYS INST UM E user manual.

5 Local diagnostic and status indicators and terminal point assignment

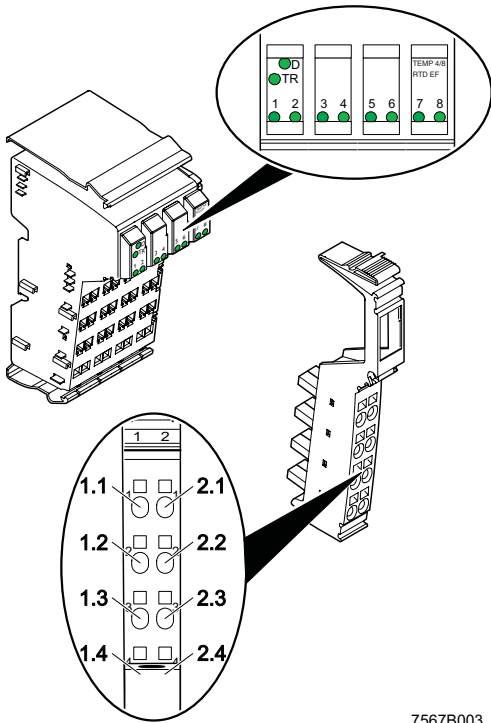

7567B003

Figure 2 Terminal with an appropriate connector

5.1 Local diagnostic and status indicators

| Des. | Color | Meaning |
|--------------------|--------------------|------------------------------------------------------------------------------------------------------------------------------------------|
| D | Green | Diagnostics |
| TR | Green | PCP |
| LED 1 ... 8 | Green ON | Measuring channel in operation |
| | Red ON | Open circuit, over-/underrange |
| | Orange | Channel scout |
| | Flashing at 0.5 Hz | Channel "n" is selected for startup purposes with the PCP object (see Section "Channel Scout object (0090 _{hex})" on page 26). |

5.2 Function identification

Green

2 Mbps: white stripe in the vicinity of the D LED

5.3 Terminal point assignment with 4-wire termination

| Terminal points | Signal | Assignment |
|-----------------|----------|-------------------------|
| 1.1 | U_{1+} | RTD sensor 1 |
| 1.2 | I_{1+} | Constant current supply |
| 1.3 | I_{1-} | |
| 1.4 | U_{1-} | RTD sensor 1 |
| 2.1 | U_{2+} | RTD sensor 2 |
| 2.2 | I_{2+} | Constant current supply |
| 2.3 | I_{2-} | |
| 2.4 | U_{2-} | RTD sensor 2 |

6 Safety notes



WARNING: Electric shock

During configuration, ensure that no isolating voltage for safe isolation is specified between the analog inputs and the bus. During thermistor detection, for example, this means that the user has to provide signals with **safe isolation**, if applicable.

7 Installation instructions

High current flowing through potential jumpers U_M and U_S leads to a temperature rise in the potential jumpers and inside the terminal. To keep the current flowing through the potential jumpers of the analog terminals as low as possible, always place the analog terminals after all the other terminals at the end of the main circuit (for the sequence of the Inline terminals: see also IL SYS INST UM E user manual).

8 Electrical isolation

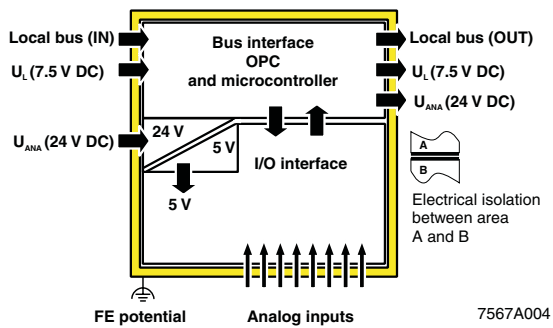

Figure 3 Electrical isolation of the individual function areas

9 Connection notes

Always connect temperature detectors using shielded, twisted-pair cables.

The connection examples show how to connect the shield (Figure 4).

Insulate the shield at the sensor.

Short-circuit unused channels (see Figure 4 on page 13, channel 4).

10 Notes on using the terminal in potentially explosive areas

Approval according to directive 94/9/EC

Ⓢ II 3 G Ex nA II T4 X

Installation notes

- This Inline terminal can be installed in zone 2.
- 1. The Inline terminal must only be installed, operated, and maintained by qualified personnel.
- 2. Please follow the installation instructions given in the IL SYS INST UM E user manual and the package slip.
- 3. Observe all applicable safety directives (even national safety regulations), accident prevention regulations, as well as general rules of technology when installing and operating the equipment.
- 4. Please refer to the corresponding documentation (user manual, data sheet, package slip) and the certificates (EC type examination and other approvals, if applicable) for safety-related data.
- 5. It is not permitted to access the circuits inside the Inline terminal. Do not repair the Inline terminal by yourself but replace it with a terminal of the same type. Repairs may only be carried out by the manufacturer.
- 6. IP20 (EN 60529) protection of the device is provided for a clean and dry environment.
- 7. Do not subject the Inline terminal to mechanical strain and/or thermal loads, which exceed the limits specified in the product documentation.
- 8. The Inline terminal has not been designed for use in dust potentially explosive atmospheres.

Installation in zone 2

1. Observe the specified conditions for use in potentially explosive areas.
2. When installing the terminal, use an appropriate and approved housing with a minimum protection of IP54. Please observe the EN 60079-14 requirements, e.g., a steel housing with a wall thickness of 3 mm.
3. In potentially explosive areas, only snap the Inline terminal onto the rail and connect the cables when the power is switched off.
4. In zone 2, only connect devices to the supply and signal circuits that are suitable for operation in potentially explosive areas of zone 2 and the conditions at the installation location.

Restrictions/limit values

1. **Only Inline terminals that are approved for use in potentially explosive areas may be snapped next to this Inline terminal.**
Before using an Inline terminal in a zone 2 potentially explosive area, first check that the terminal has been approved for installation in this area.
For a list of terminals approved for use in zone 2 potentially explosive areas, please refer to the AH EN IL EX ZONE 2 application note.
2. Please make sure that the **maximum permissible current of 4 A** flowing through potential jumpers U_M and U_S (total current) is not exceeded when using the Inline terminals in potentially explosive areas.
3. Also ensure that the **maximum permissible current of 2 A** flowing through potential jumper U_L is not exceeded.
4. The maximum permissible current for each tension spring contact is 2 A.

11 Connection examples



Connect the braided shield of the sensor cable at **one end** only.
 For the assignments illustrated below, it is absolutely necessary to connect the cable shield at a central point in the control cabinet. The braided shield can be connected to a shield busbar using, for example, a shield connection clamp of SK8 type, Order No. 3025163.

11.2 3-wire termination



Manufacturer recommendation
 To improve the measured results of a 3-wire sensor on long sensor cables, Phoenix Contact recommends always combining 4-wire termination with the 3-wire sensor (see Figure 6 on page 14).

11.1 4-wire termination

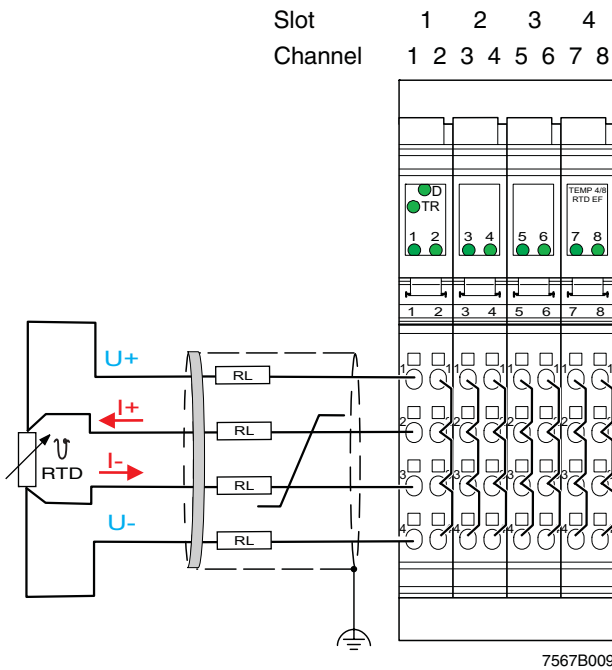

Figure 4 4-wire termination example

Example assignment:

| Channel | Connection method | Remark |
|---------|--------------------|----------------------------------|
| 1 | 4-wire termination | |
| 2 ... 8 | Not used | Insert the short-circuit jumper. |

| | | | | |
|---------|-----|-----|-----|-----|
| Slot | 1 | 2 | 3 | 4 |
| Channel | 1 2 | 3 4 | 5 6 | 7 8 |

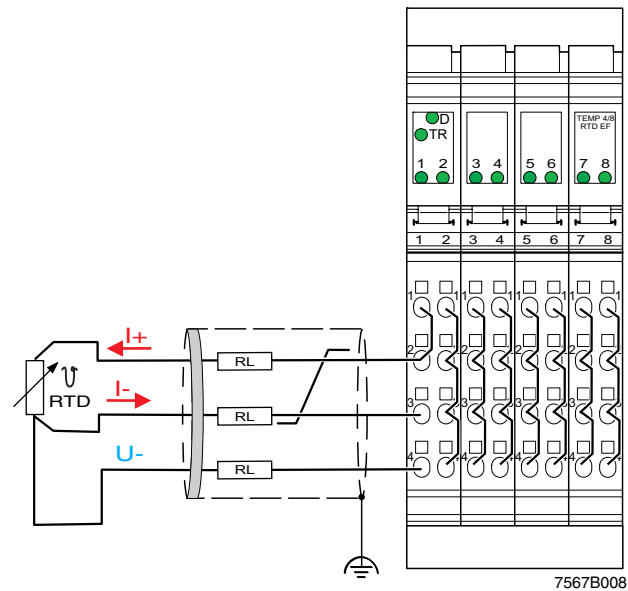

Figure 5 3-wire termination example

11.3 4-wire termination using a sensor in 3-wire technology

According to the assignment example illustrated below, RTD 3-wire sensors can also be used for long sensor cables with optimum accuracy using 4-wire termination of the terminal. This compensates for possible cable interferences, which may occur in conjunction with very long sensor cable lengths due, for example, to cable resistances, capacitances and inductances. In addition, the temperature drift of the connection cable is eliminated.

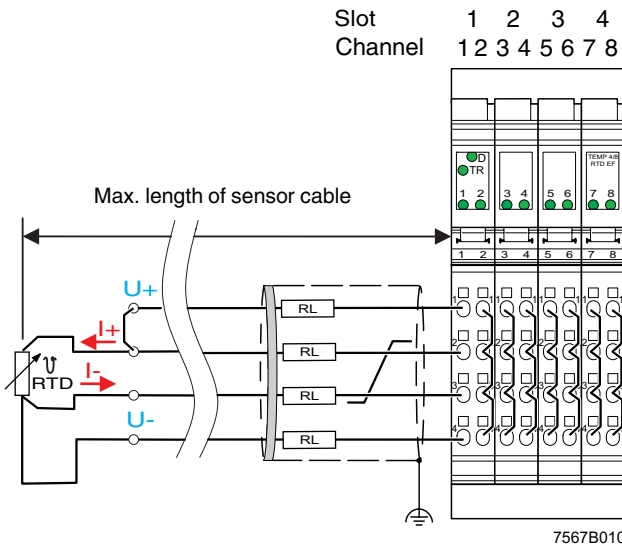

Figure 6 4-wire termination example using a sensor in 3-wire technology

11.4 2-wire termination

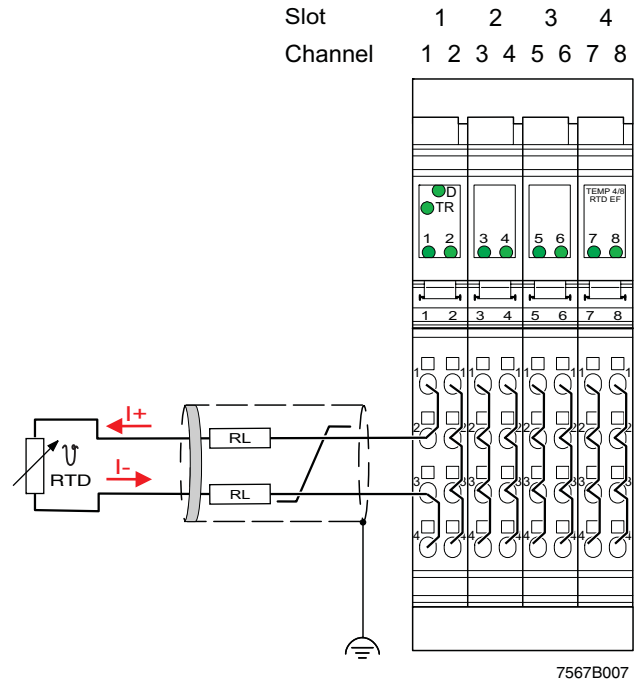

Figure 7 2-wire termination example

12 Programming data/ configuration data

Local bus (INTERBUS)

| | |
|-------------------------|-----------------------------------------|
| ID code | DF _{hex} (223 _{dec}) |
| Length code | 05 _{hex} |
| Process data channel | 80 bits |
| Input address area | 5 words |
| Output address area | 5 words |
| Parameter channel (PCP) | 1 word |
| Register length (bus) | 6 words |

Other bus systems



For the programming/configuration data of other bus systems, please refer to the corresponding electronic device data sheet (e.g., GSD, EDS).

13 Process data

The module has five process data words. The first word is the control word, which is used to execute all actions. As confirmation for an action, the first input word contains a partial copy of the control word. The error bit indicates whether a command was carried out without errors. For the command codes 4x, 5x and 60, a set error bit indicates an invalid configuration. For the commands used to read the measured values (command codes 00 ... 09), the error bit represents a group error message. If the error bit is set, there will be an error message on one or more channels.

The terminal has five process data words and one PCP word.

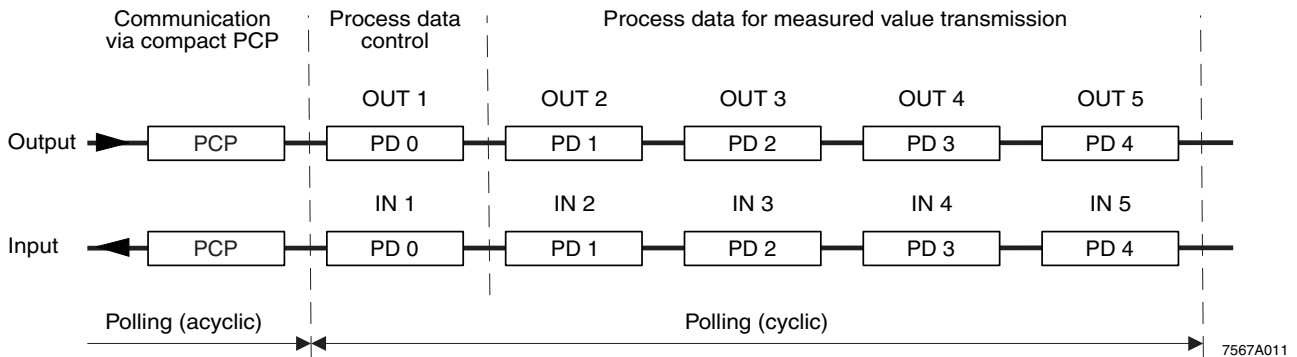

Figure 8 Order of the PCP word and the process data words

14 Process data output words OUT

Five process data output words are available.

Configure the terminal channels via the process data output words OUT1 and OUT2. In this context, the output word OUT1 contains the command and output word OUT2 the parameters belonging to this command.

Configuration errors are indicated in the status word. The configuration settings are stored in a volatile memory.

If you change the configuration, the message "Measured value invalid" appears (diagnostic code 8004_{hex}), until new measured values are available.



Please note that extended diagnostics is only possible if the IB IL format is configured as the format for the representation of measured values. As this format is preset on the terminal, it is available immediately after the voltage has been applied.

14.1 Output word OUT1 (control word)

| | | OUT1 | | | | | | | | | | | | | | | |
|-----|------------|--------------|----|----|----|----|----|---|---|---|---|-----|---|---|---|---|---|
| Bit | Assignment | 15 | 14 | 13 | 12 | 11 | 10 | 9 | 8 | 7 | 6 | 5 | 4 | 3 | 2 | 1 | 0 |
| | | Command code | | | | | | | | 0 | 0 | ODS | | 0 | 0 | 0 | 0 |

Bit 15 to bit 8 (command code):

| Bit | | | | | | | | OUT1 | Command function |
|-----|----|----|----|----|----|---|---|---------------------|--------------------------------------------------------------------------------------------------------------------------------------|
| 15 | 14 | 13 | 12 | 11 | 10 | 9 | 8 | | |
| 0 | 0 | 0 | 0 | 0 | C | C | C | 0x00 _{hex} | Read measured value in IN2 channel-by-channel. |
| 0 | 0 | 0 | 0 | 1 | 0 | 0 | 0 | 0800 _{hex} | Read measured values of channels 1 to 4 in IN2 to IN5. |
| 0 | 0 | 0 | 0 | 1 | 0 | 0 | 1 | 0900 _{hex} | Read measured values of channels 5 to 8 in IN2 to IN5. |
| 0 | 0 | 0 | 1 | 0 | C | C | C | 1x00 _{hex} | Read configuration in IN2 channel-by-channel. |
| 0 | 0 | 1 | 1 | 1 | 1 | 0 | 0 | 3C00 _{hex} | Read device data. The firmware version and the device ID number are represented in IN2 (see Section 15.2 "Input words IN2 to IN5"). |
| 0 | 1 | 0 | 0 | 0 | C | C | C | 4x00 _{hex} | Configure channel, configuration in OUT2. |
| 0 | 1 | 0 | 1 | 0 | C | C | C | 5x00 _{hex} | Configure channel and read measured value of the channel, configuration in OUT2, measured value in IN2. |
| 0 | 1 | 1 | 0 | 0 | 0 | 0 | 0 | 6000 _{hex} | Configure entire terminal (all channels); configuration in OUT2. |

CCC = channel number

Channel assignment:

| Bit | | | Channel number |
|-----|---|---|----------------|
| 10 | 9 | 8 | |
| 0 | 0 | 0 | 1 |
| 0 | 0 | 1 | 2 |
| 0 | 1 | 0 | 3 |
| 0 | 1 | 1 | 4 |
| 1 | 0 | 0 | 5 |
| 1 | 0 | 1 | 6 |
| 1 | 1 | 0 | 7 |
| 1 | 1 | 1 | 8 |

Bits 5 and 4 (ODS: open circuit detection sensitivity;
firmware version 1.10 or later)

| Bit | | ODS: open circuit detection sensitivity |
|-----|---|-----------------------------------------|
| 5 | 4 | |
| 0 | 0 | High sensitivity |
| 0 | 1 | Medium sensitivity |
| 1 | 0 | Reserved |
| 1 | 1 | OFF |



Please also observe the "Notes on diagnostic behavior in the event of an error" on page 33.

14.2 Output word OUT2 (parameter word)

The parameters for the commands 4x00_{hex}, 5x00_{hex}, and 6000_{hex} must be specified in OUT2. This parameter word is only evaluated for these commands.

| | | OUT2 | | | | | | | | | | | | | | | |
|------------|--|------|-------------|----|----|----------------|----|---|------------|---|--------|---|-------------|---|---|---|---|
| Bit | | 15 | 14 | 13 | 12 | 11 | 10 | 9 | 8 | 7 | 6 | 5 | 4 | 3 | 2 | 1 | 0 |
| Assignment | | 0 | Filter time | | 0 | R ₀ | | | Resolution | | Format | | Sensor type | | | | |

- R₀ Selection of sensor resistance at 0°C.
Here, for example, you can select whether Pt100, Pt500 or Pt1000 are to be used for the platinum sensor type.
- Resolution Quantization of the measured value, select between °Celsius or °Fahrenheit.
- Format Representation of the measured value in the IN process data
- Sensor type Sensor type setting



If invalid parameters are specified in the parameter word, the command will not be executed. The command is acknowledged in the input words with the error bit set.

14.3 Parameters for configuration

The module can be configured either via process data or PCP. The error code "Measured value invalid" is output during configuration. If the configuration is invalid, the error bit is set in the status word. The configuration is only stored in a volatile memory. The first output word must contain the command, the second output word must contain the configuration value.

| | | OUT2 | | | | | | | | | | | | | | | |
|------------|--|------|-------------|----|----|----------------|----|---|------------|---|--------|---|-------------|---|---|---|---|
| Bit | | 15 | 14 | 13 | 12 | 11 | 10 | 9 | 8 | 7 | 6 | 5 | 4 | 3 | 2 | 1 | 0 |
| Assignment | | 0 | Filter time | | 0 | R ₀ | | | Resolution | | Format | | Sensor type | | | | |

Default settings are marked in **bold**.

Bits 14 and 13:

| Code | Filter time |
|------|---------------|
| 00 | 480 ms |
| 01 | 120 ms |
| 10 | 101 ms |
| 11 | 200 ms |

Bits 11 to 8:

| Code | | R ₀ [Ω] |
|----------|-------------|--------------------|
| dec | bin | |
| 0 | 0000 | 100 |
| 1 | 0001 | 10 |
| 2 | 0010 | 20 |
| 3 | 0011 | 30 |
| 4 | 0100 | 50 |
| 5 | 0101 | 120 |
| 6 | 0110 | 150 |
| 7 | 0111 | 200 |

| Code | | R ₀ [Ω] |
|------|------|--------------------|
| dec | bin | |
| 8 | 0008 | 240 |
| 9 | 0009 | 300 |
| 10 | 000A | 400 |
| 11 | 000B | 500 |
| 12 | 000C | 1000 |
| 13 | 000D | 1500 |
| 14 | 000E | 2000 |
| 15 | 000F | 10000 |

Bits 7 and 6:

| Code | | Resolution for sensor type | | | |
|----------|-----------|----------------------------|----------------------|---------------------|----------------------|
| dec | bin | All temperature sensors | Linear R 0 ... 500 Ω | Linear R 0 ... 5 kΩ | Linear R 0 ... 30 kΩ |
| 0 | 00 | 0.1°C | 0.1 Ω | 1 Ω | 1 Ω |
| 1 | 01 | 0.01°C | 0.01 Ω | 0.1 Ω | res. |
| 2 | 10 | 0.1°F | Reserved | | |
| 3 | 11 | 0.01°F | | | |

Bits 5 and 4:

| Code | | Format |
|----------|-----------|--------------------------------------------------------------------|
| dec | bin | |
| 0 | 00 | IB IL format (15 bits + sign bit with extended diagnostics) |
| 1 | 01 | Reserved |
| 2 | 10 | S7 format compatible (15 bits + sign bit) |
| 3 | 11 | Reserved |

Bits 3 to 0:

| Code | | Sensor type |
|------|------|------------------------------|
| dec | bin | |
| 0 | 0000 | Pt DIN |
| 1 | 0001 | Pt SAMA |
| 2 | 0010 | Ni DIN |
| 3 | 0011 | Ni SAMA |
| 4 | 0100 | Cu10 |
| 5 | 0101 | Cu50 |
| 6 | 0110 | Cu53 |
| 7 | 0111 | Ni1000 (Landis & Gyr) |
| 8 | 1000 | Ni500 (Viessmann) |
| 9 | 1001 | KTY 81-110 |
| 10 | 1010 | KTY 84 |
| 11 | 1011 | KTY 81-210 |
| 12 | 1100 | Linear R 0 ... 30 k Ω |
| 13 | 1101 | Reserved |
| 14 | 1110 | Linear R 0 ... 500 Ω |
| 15 | 1111 | Linear R 0 ... 5 k Ω |

15 Process data input words IN

15.1 Input word IN1 (status word)

Input word IN1 performs the task of a status word.

| | | IN1 | | | | | | | | | | | | | | | |
|------------|----|-------------------------------|----|----|----|----|----|---|---|---|---|---|---|---|---|---|---|
| Bit | | 15 | 14 | 13 | 12 | 11 | 10 | 9 | 8 | 7 | 6 | 5 | 4 | 3 | 2 | 1 | 0 |
| Assignment | EB | Mirroring of the command code | | | | | | | | 0 | 0 | 0 | 0 | 0 | 0 | 0 | 0 |

EB: Error bit

EB = 0 No error has occurred.

EB = 1 An error has occurred.

Mirroring of the command code:

A command code mirrored from the control word. Here, the MSB is suppressed.

15.2 Input words IN2 to IN5

The measured values, the configuration or the firmware version are transmitted to the controller board or the PC using the process data input words IN2 to IN5 in accordance with the configuration.

For the control word **3C00_{hex}**, IN2 supplies the firmware version and the module ID.

Example: Firmware version 1.23:

| | | IN2 | | | | | | | | | | | | | | | |
|------------------|--|-----------------------|----|----|----|----|----|---|---|---|---|---|---|------------------|---|---|---|
| Bit | | 15 | 14 | 13 | 12 | 11 | 10 | 9 | 8 | 7 | 6 | 5 | 4 | 3 | 2 | 1 | 0 |
| Assignment (hex) | | 1 | | | | 2 | | | | 3 | | | | E _{hex} | | | |
| Meaning | | Firmware version 1.23 | | | | | | | | | | | | Module ID | | | |

Basically two formats are available for the representation of the measured values. For more detailed information on the formats, please refer to Section "Formats for representing measured values" on page 20.

| MSB | | | | | | | | | | | | | | | LSB |
|-----|--------------|----|----|----|----|---|---|---|---|---|---|---|---|---|---------------------------------------|
| 15 | 14 | 13 | 12 | 11 | 10 | 9 | 8 | 7 | 6 | 5 | 4 | 3 | 2 | 1 | 0 |
| SB | Analog value | | | | | | | | | | | | | | IB IL format, S7 format compatible |

MSB Most significant bit

LSB Least significant bit

SB Sign bit

AV Analog value

16 Formats for representing measured values

16.1 IB IL format (default setting)

The measured value is represented in bits 14 to 0. An additional bit (bit 15) is available as a sign bit. This format supports extended diagnostics. Values $>8000_{\text{hex}}$ and $<8100_{\text{hex}}$ indicate an error.

Measured value representation in IB IL format, 15 bits

| | | | | | | | | | | | | | | | | | |
|-----|--------------|----|----|----|----|----|---|---|---|---|---|---|---|---|---|---|-----|
| MSB | 15 | 14 | 13 | 12 | 11 | 10 | 9 | 8 | 7 | 6 | 5 | 4 | 3 | 2 | 1 | 0 | LSB |
| SB | Analog value | | | | | | | | | | | | | | | | |

SB Sign bit

| IB input word | | All temperature sensors [°C/°F] | | R ₀ up to 500 Ω | | R ₀ up to 5 kΩ | |
|---------------|------------|---------------------------------|---------------|----------------------------|---------|---------------------------|---------|
| Code (hex) | dec | Resolution | Resolution | Resolution | | Resolution | |
| | | 0.1°C/°F | 0.01°C/°F | 0.1 Ω | 0.01 Ω | 1 Ω | 0.1 Ω |
| 8001 | Overrange | > Limit value | > Limit value | >525 | >325.12 | >5250 | >3251.2 |
| 0FA0 | 1000 | +100.0 | +10.0 | 100.0 | 10.0 | 1000.0 | 100.0 |
| 0001 | 1 | +0.1 | +0.01 | +0.1 | +0.01 | +1.0 | +0.1 |
| 0000 | 0 | 0 | 0 | ≤ 0 | ≤ 0 | ≤ 0 | ≤ 0 |
| FFFF | -1 | -0.1 | -0.01 | - | - | - | - |
| FC18 | -1000 | -100.0 | -10.0 | - | - | - | - |
| 8080 | Underrange | < Limit value | < Limit value | - | - | - | - |

The following diagnostic codes are supported:

| Code (hex) | Error |
|------------|--------------------------------------------------------------------------------------------------------------|
| 8001 | Overrange |
| 8002 | Open circuit |
| 8004 | Measured value invalid/no valid measured value available (e.g., because the channel has not been configured) |
| 8010 | Invalid configuration |
| 8020 | I/O supply voltage faulty |
| 8040 | Terminal faulty |
| 8080 | Underrange |



If the measured value is outside the representation area of the process data, the error message "Overrange" or "Underrange" is displayed.

16.2 S7 format compatible

The measured value for temperature and resistance values is represented in bits 14 through 0. An additional bit (bit 15) is available as a sign bit.

Measured value representation in S7 format, 15 bits

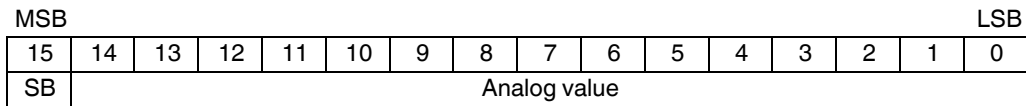

SB Sign bit

| IB input word | | All temperature sensors [°C/°F] | | 0 to 500 Ω | | 0 to 5 kΩ | |
|---------------|------------|---------------------------------|---------------|------------|---------|------------|---------|
| Code (hex) | dec | Resolution | Resolution | Resolution | | Resolution | |
| | | 0.1°C/°F | 0.01°C/°F | 0.1 Ω | 0.01 Ω | 1 Ω | 0.1 Ω |
| 7FFF | Overrange | > Limit value | > Limit value | >525 | >325.12 | >5250 | >3251.2 |
| 0FA0 | 1000 | +100.0 | +10.0 | 100.0 | 10.0 | 1000.0 | 100.0 |
| 0001 | 1 | +0.1 | +0.01 | +0.1 | +0.01 | +1.0 | +0.1 |
| 0000 | 0 | 0 | 0 | ≤ 0 | ≤ 0 | ≤ 0 | ≤ 0 |
| FFFF | -1 | -0.1 | -0.01 | - | - | - | - |
| FC18 | -1000 | -100.0 | -10.0 | - | - | - | - |
| 8000 | Underrange | < Limit value | < Limit value | - | - | - | - |

The following diagnostic codes are possible:

| Code (hex) | Error |
|------------|--------------------------------------------------------------------------------------------------------------|
| 7FFF | Overrange |
| 8002 | Open circuit |
| 8004 | Measured value invalid/no valid measured value available (e.g., because the channel has not been configured) |
| 8010 | Invalid configuration |
| 8020 | I/O supply voltage faulty |
| 8040 | Terminal faulty |
| 8000 | Underrange |



If the measured value is outside the representation area of the process data, the error message "Overrange" or "Underrange" is displayed.

17 PCP communication



For information on PCP communication, please refer to the IBS SYS PCP G4 UM E (Order No. 2745169) and IBS PCP COMPACT UM E (Order No. 9015349) user manuals.

By default upon delivery, the terminal is configured according to the default settings. To adapt the configuration, the terminal can be configured via process data or PCP.

In PCP mode, the terminal is configured using the "Config Table" object.



The programs IBS CMD (for standard controller boards) and IBS PC WORX (for Field Controllers [FC] and Remote Field Controllers [RFC]) are available for the configuration and parameterization of your INTERBUS system.

For additional information, please refer to the IBS CMD SWT G4 UM E user manual and the documentation for the version of PC WorX used.

17.1 Object dictionary

| Index | Object name | Meaning | Data type | N | L | Rights |
|---------------------|----------------------|-----------------------------------------|----------------------|----|---|--------|
| 0018 _{hex} | DiagState | Diagnostic status | Record | | 6 | rd |
| 0080 _{hex} | Config Table | Configuration table | Array of Unsigned 16 | 12 | 2 | rd/wr |
| 0081 _{hex} | Analog Values | Measured value in 16-bit format | Array of Unsigned 16 | 8 | 2 | rd |
| 0082 _{hex} | Measured Value Float | Measured value in extended float format | Record | 8 | 6 | rd |
| 0090 _{hex} | Channel Scout | Channel scout | Unsigned 8 | 1 | 1 | rd/wr |

N: Number of elements rd: Read access permitted
 L: Length of an element in bytes wr: Write access permitted

18 Object descriptions

18.1 DiagState object (0018_{hex})

Object description:

The object is used for structured error reporting and is defined in the basic profile.

| Subindex | Data type | Meaning | Contents |
|----------|-------------|----------------------|-----------------------------------------------------------------------------------------------------------------------------------------------------------------------------------------------------------------------|
| 1 | Unsigned 16 | Error number | 0 ... 65535 |
| 2 | Unsigned 8 | Priority | ErrorCode = 0000 _{hex} -> prio: 00 _{hex} , otherwise 02 _{hex} |
| 3 | Unsigned 8 | Channel | ErrorCode = 0000 _{hex} -> channel: 00 _{hex} , otherwise 01 _{hex} ... 08 _{hex} |
| 4 | Unsigned 16 | Error code | 0000 _{hex} : OK, 8910 _{hex} : Overrange, 8920 _{hex} : Underrange, 7710 _{hex} : Open circuit, 5160 _{hex} : Powerfail, 5010 _{hex} : Hardware fault |
| 5 | Unsigned 8 | More follows | 00 |
| 6 | OctetString | Text (10 characters) | ErrorCode=0000-> Text: 'Status OK', otherwise error-specific |

18.2 Config Table object (0080_{hex})

Configure the terminal using this object.

Object description:

| | | | |
|----------------|-------------------------------------------------------------------------------------------------------------------------------------------------------------------------------------------------------------------------------------------------------------------------------|----------------------------------------------------------------------------------------------------------------------------------------------------------------------------------------------------------------------------------------------------------------------------------------------------------------------------------------------------|--|
| Object | Config Table | | |
| Access | Read, write | | |
| Data type | Array of unsigned 16 | 12 x 2 bytes | |
| Index | 0080 _{hex} | | |
| Subindex | 00 _{hex} 01 _{hex} 02 _{hex} 03 _{hex} 04 _{hex} 05 _{hex} 06 _{hex} 07 _{hex} 08 _{hex} 09 _{hex} 0A _{hex} 0B _{hex} 0C _{hex} | Write all elements Configuration of channel 1 Configuration of channel 2 Configuration of channel 3 Configuration of channel 4 Configuration of channel 5 Configuration of channel 6 Configuration of channel 7 Configuration of channel 8 Reserved ODS (open circuit detection sensitivity) Reserved Reserved | |
| Length (bytes) | 18 _{hex} 02 _{hex} | Subindex 00 _{hex} Subindex 01 _{hex} to 0C _{hex} | |
| Data | Terminal configuration | | |

Value range:

ODS (firmware 1.10 or later)

| | | | | | | | | | | | | | | | | |
|------------|----|----|----|----|----|----|---|---|---|---|-----|---|---|---|---|---|
| Bit | 15 | 14 | 13 | 12 | 11 | 10 | 9 | 8 | 7 | 6 | 5 | 4 | 3 | 2 | 1 | 0 |
| Assignment | 0 | 0 | 0 | 0 | 0 | 0 | 0 | 0 | 0 | 0 | ODS | | 0 | 0 | 0 | 0 |

Bits 5 and 4 (ODS: open circuit detection sensitivity)

| Bit | ODS: open circuit detection sensitivity |
|-----|-----------------------------------------|
| 5 4 | |
| 0 0 | High sensitivity |
| 0 1 | Medium sensitivity |
| 1 0 | Reserved |
| 1 1 | OFF |

18.3 Analog Values object (0081_{hex})

The elements of this object contain the analog values of the channels in a format that has been selected for this channel.

Object description:

| | | |
|----------------|-------------------------------------------------------------------------------------------------------------------------------------------------------------------------------------------|-----------------------------------------------------------------------------------------------------------------------------------------------------------------------------------------------------------------------------------------------------------|
| Object | Analog Values | |
| Access | Read | |
| Data type | Array of unsigned 16 | 8 x 2 bytes |
| Index | 0081 _{hex} | |
| Subindex | 00 _{hex} 01 _{hex} 02 _{hex} 03 _{hex} 04 _{hex} 05 _{hex} 06 _{hex} 07 _{hex} 08 _{hex} | Read all elements Analog value of channel 1 Analog value of channel 2 Analog value of channel 3 Analog value of channel 4 Analog value of channel 5 Analog value of channel 6 Analog value of channel 7 Analog value of channel 8 |
| Length (bytes) | 10 _{hex} 02 _{hex} | Subindex 00 _{hex} Subindex 01 _{hex} to 08 _{hex} |
| Data | Analog values of the channels | |

18.4 Measured Value Float object (0082_{hex})



This format provides the highest internal module accuracy and is independent of the configured resolution.

Object description:

| | | | |
|----------------|----------------------------------------------------------------------------------------------------------------------------------------------------------------------|--------------------------------------------------------------------------------------------------------------------------------------------------------------------------------------------------------------------------------------|--|
| Object | Measured Value Float | | |
| Access | Read | | |
| Data type | Array of record | 8 x 6 bytes | |
| Index | 0082 _{hex} | | |
| Subindex | 01 _{hex} 02 _{hex} 03 _{hex} 04 _{hex} 05 _{hex} 06 _{hex} 07 _{hex} 08 _{hex} | Analog value of channel 1 Analog value of channel 2 Analog value of channel 3 Analog value of channel 4 Analog value of channel 5 Analog value of channel 6 Analog value of channel 7 Analog value of channel 8 | |
| Length (bytes) | 30 _{hex} 06 _{hex} | Subindex 00 _{hex} Subindex 01 _{hex} to 08 _{hex} | |
| Data | Analog values of the channels | | |

The extended float format is a specific format from Phoenix Contact and consists of the measured value, the status and the unit code. The status is required as there are no patterns informing about the status of the value defined in the float format. The status corresponds to the lower bytes of the Inline error codes. For example, if status = 01 with overrange, the Inline error code is 8001 hex. If status = 0, the measured value is valid.

Measured value record:

| Element | Data type | Length in bytes | Meaning |
|---------|------------|-----------------|------------------------------------------------------|
| .1 | Float | 4 | Measured value in float format according to IEEE 754 |
| .2 | Unsigned 8 | 1 | Status |
| .3 | Unsigned 8 | 1 | Unit code: 32: °C, 33: °F, 37: Ω |

Structure of the float format according to IEEE 754

| | | | | | | | | |
|------------|------|------|------|------|------|------|------|------|
| Bit | 25 | | 17 | | 9 | | 1 | |
| Assignment | SEEE | EEEE | EMMM | MMMM | MMMM | MMMM | MMMM | MMMM |

S = 1 sign bit, 0: positive, 1: negative

E = 8 bits, exponent with offset 7F_{hex}

M = 23 bits, mantissa

Example values for the float format

| | |
|------------|----------------------------|
| 1.0 | 3F 80 00 00 _{hex} |
| -1.0 | BF 80 00 00 _{hex} |
| 10 | 41 20 00 00 _{hex} |
| 1.03965528 | 3F 85 13 6D _{hex} |

18.5 Channel Scout object (0090_{hex})

The channel scout function supports the fast discovery of a measuring channel on the Inline terminal (e.g., during startup).



The channel scout functionality is superior to all diagnostic messages of the selected LED and must be disabled separately by the user. In comparison, the configuration of a channel automatically causes this functionality to be aborted.

Object description:

| | | | |
|----------------|----------------------------|----------------------------|--|
| Object | Channel Scout | | |
| Access | Read/write | | |
| Data type | Unsigned | 1 bytes | |
| Index | 0090 _{hex} | | |
| Length (bytes) | 01 _{hex} | Subindex 00 _{hex} | |
| Data | Control of the channel LED | | |

Value range:

| | |
|---------|-----------------------------------------------------------------------------|
| 0 | Disable all channel scout processes |
| 1 ... 8 | Orange LED of the channel is flashing at 0.5 Hz (1 second ON, 1 second OFF) |

19 Configuration and analog values

The terminal only needs to be configured if the channels are not to be operated with the default values (see "Parameters for configuration" on page 17).

You can configure the terminal **either** using process data **or** using PCP and transmit the analog values accordingly.

If you have configured the terminal via PCP, the configuration can no longer be modified using the process data.

Examples for the terminal configuration via process data



For easy terminal configuration a function block can be downloaded at www.phoenixcontact.net/catalog.

20 Temperature and resistance measuring ranges

20.1 Measuring ranges depending on the resolution (IB IL format)

| Resolution | Temperature sensors |
|------------|----------------------------------------------|
| 00 | -273°C up to +3276.8°C Resolution: 0.1°C |
| 01 | -273°C up to +327.68°C Resolution: 0.01°C |
| 10 | -459°F up to +3276.8°F Resolution: 0.1°F |
| 11 | -459°F up to +327.68°F Resolution: 0.01°F |



Temperature values can be converted from °C to °F with this formula:

$$T [^{\circ}\text{F}] = T [^{\circ}\text{C}] \times \frac{9}{5} + 32$$

Where:

- T [°F] Temperature in °F
- T [°C] Temperature in °C

21 Measuring errors due to connection cables

21.1 4-wire technology

The terminal provides 4-wire technology for all eight channels and supports the maximum connection length of 250 meters for each sensor. Additional measuring tolerances caused by the cable length do not occur.

21.2 Systematic errors during temperature measurement using 2-wire technology

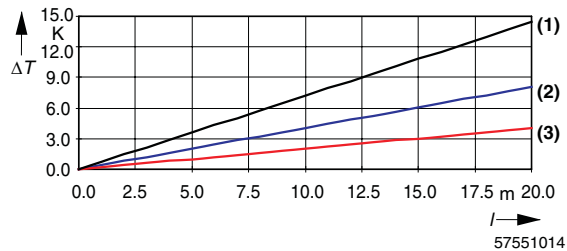

Figure 9 Systematic temperature measuring error ΔT depending on the cable length l

Curves depending on the cable cross-section A

- (1) Temperature measuring error for $A = 0.14 \text{ mm}^2$
- (2) Temperature measuring error for $A = 0.25 \text{ mm}^2$
- (3) Temperature measuring error for $A = 0.50 \text{ mm}^2$

(Measuring error valid for: copper cable $\chi = 57 \text{ m}/\Omega\text{mm}^2$, $T_A = 25^{\circ}\text{C}$ and Pt100 sensor)

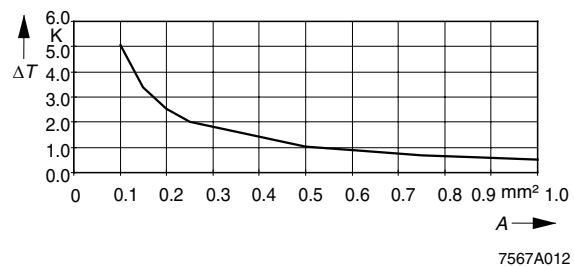

Figure 10 Systematic temperature measuring error ΔT depending on the cable cross-section A

(Measuring error valid for: copper cable $\chi = 57 \text{ m}/\Omega\text{mm}^2$, $T_A = 25^{\circ}\text{C}$, $l = 5 \text{ m}$ and Pt100 sensor)

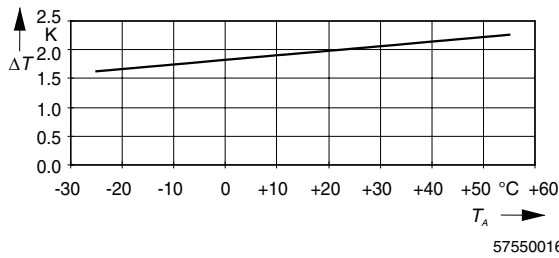

Figure 11 Systematic temperature measuring error ΔT depending on the cable temperature T_A

(Measuring error valid for: copper cable $\chi = 57 \text{ m}/\Omega\text{mm}^2$, $l = 5 \text{ m}$, $A = 0.25 \text{ mm}^2$ and Pt100 sensor)

All diagrams show that the measuring error is due to the increase in cable resistance.

A considerable improvement is made through the use of Pt1000 sensors. Due to the 10-fold higher temperature coefficient α ($\alpha = 0.385 \Omega/\text{K}$ for Pt100 to $\alpha = 3.85 \Omega/\text{K}$ for Pt1000) the effect of the cable resistance on the measurement is decreased by factor 10. All errors in the diagrams above would be reduced by a factor of 10.

Figure 9 clearly shows the effect of the cable length on the cable resistance and therefore on the measuring error. The solution is to use the shortest possible sensor cables.

Figure 10 shows the influence of the cable cross-section on the cable resistance. It can be seen that cables with a diameter of less than 0.5 mm^2 cause the error to increase exponentially.

Figure 11 shows the influence of the ambient temperature on the cable resistance. This parameter is of minor importance and can hardly be influenced. It is mentioned here only in the interest of completeness.

The equation for calculating the cable resistance is as follows:

$$R_L = R_{L20} \times \left(1 + 0.0039 \frac{1}{\text{K}} \times (T_A - 20^\circ\text{C}) \right)$$

$$R_L = \frac{l}{\chi \times A} \times \left(1 + 0.0039 \frac{1}{\text{K}} \times (T_A - 20^\circ\text{C}) \right)$$

Where:

| | |
|----------------------|--------------------------------------------------------------------------|
| R_L | Cable resistance in Ω |
| R_{L20} | Cable resistance at 20°C in Ω |
| l | Cable length in m |
| χ | Specific electrical resistance of copper in $\text{m}/\Omega\text{mm}^2$ |
| A | Cable cross-section in mm^2 |
| 0.0039 1/K | Temperature coefficient for copper (percentage purity of 99.9%) |
| T_A | Ambient temperature (cable temperature) in $^\circ\text{C}$ |

Since there are two cable resistances in the measuring system (forward and return), the value must be doubled. Using the average temperature coefficient α ($\alpha = 0.385 \Omega/\text{K}$ for Pt100; $\alpha = 3.85 \Omega/\text{K}$ for Pt1000), the absolute measuring error in Kelvin [K] can be determined for platinum sensors according to DIN standards.

22 Calculation examples

22.1 Typical temperature behavior

Task:

Temperatures of up to +45°C are achieved in the control cabinet.

1. What typical drift values of the measuring inputs are to be expected for temperature measurement with a Pt100 sensor using 4-wire technology at a measuring temperature of +180°C for this terminal?
2. What typical measuring tolerance is to be expected at +45°C?

Calculation of typical drift values:

The temperature difference is calculated using the formula (1):

$$\Delta T_A = T_S - 25\text{ °C} \quad (1)$$

Where:

ΔT_A Temperature difference (difference between current switch cabinet temperature and reference temperature of +25°C)

T_S Current temperature in the switch cabinet

Value for this example:

$$T_S = 45\text{ °C}$$

According to formula (1)

$$\begin{aligned} \Delta T_A &= T_S - 25\text{ °C} \\ &= 45\text{ °C} - 25\text{ °C} \\ &= 20\text{ K} \end{aligned}$$

The temperature drift of the Pt100 sensor is calculated according to formula (2):

$$T_{\text{Drift}} = \Delta T_A \times T_C \times T_M \quad (2)$$

Where:

T_{Drift} Temperature drift of the Pt100 sensor

ΔT_A Temperature difference; from formula (1)

T_C Temperature coefficient; see "Temperature and drift response at $T_A = -25\text{ °C}$ to $+55\text{ °C}$ ($+60\text{ °C}$)³⁾" on page 6

T_M Measuring temperature

Values for this example:

$$\Delta T_A = 20\text{ K}$$

$$T_C = \pm 5\text{ ppm/K (typical drift)}$$

$$T_M = 180\text{ °C}$$

According to formula (2)

$$\begin{aligned} T_{\text{Drift}} &= \Delta T_A \times T_C \times T_M \\ &= 20\text{ K} \times \pm 5\text{ ppm/K} \times 180\text{ °C} \\ &= 20 \times \pm 5 \times 10^{-6} \times 180\text{ °C} \\ &= \pm 0.018\text{ K} \\ T_{\text{Drift}} &= \pm 0.02\text{ K} \end{aligned}$$

Solution:

Under these marginal conditions, a typical temperature drift of 0.02 K is to be expected.

Calculation of the typical measuring tolerance:

The measuring tolerance is calculated using the formula (3):

$$\Delta T_{\text{Tot}} = \Delta T_{25} + T_{\text{Drift}} \quad (3)$$

Where:

ΔT_{Tot} Total tolerance

ΔT_{25} Tolerance at 25°C; see "Tolerances (typical/maximum) at $T_A = +25\text{ °C}$ " on page 5

T_{Drift} Drift at 45°C; from formula (2)

Values for this example:

$$\Delta T_{25} = \pm 0.05\text{ K}$$

$$T_{\text{Drift}} = \pm 0.02\text{ K}$$

According to formula (3)

$$\begin{aligned} \Delta T_{\text{Tot}} &= \Delta T_{25} + T_{\text{Drift}} \\ &= \pm 0.05\text{ K} + \pm 0.02\text{ K} \\ &= \pm 0.07\text{ K} \end{aligned}$$

Solution:

With an ambient temperature of +45°C, a typical measuring tolerance of ±0.07 K is to be expected.

22.2 Maximum temperature behavior (worst case)

Task:

Temperatures of up to +40°C are achieved in the control cabinet.

What typical drift values of the measuring inputs are to be expected for temperature measurement with a Pt100 sensor using 4-wire technology at a measuring temperature of +200°C for this terminal?

Calculation:

The measuring tolerance is calculated using the formula (3):

$$\Delta T_{\text{Tot}} = \Delta T_{25} + T_{\text{Drift}} \quad (3)$$

Values for this example:

$$\Delta T_{25} = \pm 0.19 \text{ K}$$

$$T_{\text{Drift}} \text{ Must be calculated}$$

To calculate the drift, proceed as described in the example for the typical temperature response.

The temperature difference is calculated using the formula (1):

$$\Delta T_A = T_S - 25^\circ\text{C} \quad (1)$$

Value for this example:

$$T_S = 40^\circ\text{C}$$

According to formula (1)

$$\begin{aligned} \Delta T_A &= T_S - 25^\circ\text{C} \\ &= 40^\circ\text{C} - 25^\circ\text{C} \\ &= 15 \text{ K} \end{aligned}$$

The maximum temperature drift of the Pt100 sensor is calculated according to formula (2):

$$T_{\text{Drift}} = \Delta T_A \times T_C \times T_M \quad (2)$$

Values for this example:

$$\Delta T_A = 15 \text{ K}$$

$$T_C = \pm 18 \text{ ppm/K (maximum drift)}$$

$$T_M = 200^\circ\text{C}$$

According to formula (2)

$$\begin{aligned} T_{\text{Drift max.}} &= \Delta T_A \times T_C \times T_M \\ &= 15 \text{ K} \times \pm 18 \text{ ppm/K} \times 200^\circ\text{C} \\ &= 15 \times \pm 18 \times 10^{-6} \times 200^\circ\text{C} \\ &= \pm 0.054 \text{ K} \end{aligned}$$

$$T_{\text{Drift max.}} = \pm 0.05 \text{ K}$$

The measuring tolerance is calculated using the formula (3):

$$\Delta T_{\text{Tot}} = \Delta T_{25} + T_{\text{Drift}} \quad (3)$$

Values for this example:

$$\Delta T_{25} = \pm 0.19 \text{ K}$$

$$T_{\text{Drift}} = \pm 0.05 \text{ K}$$

According to formula (3)

$$\begin{aligned} \Delta T_{\text{Tot}} &= \Delta T_{25} + T_{\text{Drift}} \\ &= \pm 0.19 \text{ K} + \pm 0.05 \text{ K} \\ &= \pm 0.24 \text{ K} \end{aligned}$$

Solution:

With an ambient temperature of +40°C, a **maximum worst case** measuring tolerance of 0.24 K is to be expected.

23 Configuration example

All eight channels of the terminal are preset to a Pt100 sensor and a filter time of 480 ms. In order to change default settings, the new configuration data should be transferred to the terminal.

Please refer to the following examples for the configuration procedure.

| Channel No. | Sensor type | Filter time | Resolution | Configuration |
|-------------|-------------|-------------|------------|---------------------|
| 1 | Pt100 DIN | 480 ms | 0.1°C | 0000 _{hex} |
| 2 | Ni100 DIN | 480 ms | 0.1°C | 0002 _{hex} |
| 3 | Lin 500 Ω | 480 ms | 0,01Ω | 004E _{hex} |
| 4 | Cu10 | 480 ms | 0.1°C | 0004 _{hex} |
| 5 | Pt100 DIN | 480 ms | 0.01°C | 0040 _{hex} |
| 6 | Pt1000 DIN | 480 ms | 0.1°C | 0C00 _{hex} |
| 7 | Ni500 DIN | 480 ms | 0.1°C | 0B02 _{hex} |
| 8 | Lin 500 kΩ | 480 ms | 1.0 Ω | 000F _{hex} |

| Step No. | Process data | Configuration |
|----------|-------------------------------------------------------------------------|-------------------------------------------|
| 1 | Out1 = 0000 _{hex} , 0800 _{hex} or 0900 _{hex} | Specify a passive command first |
| 2 | Wait until In1 = Out1 | Wait for confirmation |
| 3 | Out2 = 0000 _{hex} Out1 = 4000 _{hex} | Configuration for channel 1 |
| 4 | Wait until In1 = Out1 | Wait for confirmation |
| 5 | Out2 = 0002 _{hex} Out1 = 4100 _{hex} | Configuration for channel 2 |
| 6 | Wait until In1 = Out1 | Wait for confirmation |
| 7 | Out2 = 004E _{hex} Out1 = 4200 _{hex} | Configuration for channel 3 |
| 8 | Wait until In1 = Out1 | Wait for confirmation |
| 9 | Out2 = 0004 _{hex} Out1 = 4300 _{hex} | Configuration for channel 4 |
| 10 | Wait until In1 = Out1 | Wait for confirmation |
| 11 | Out2 = 0040 _{hex} Out1 = 4400 _{hex} | Configuration for channel 5 |
| 12 | Wait until In1 = Out1 | Wait for confirmation |
| 13 | Out2 = 0C00 _{hex} Out1 = 4500 _{hex} | Configuration for channel 6 |
| 14 | Wait until In1 = Out1 | Wait for confirmation |
| 15 | Out2 = 0B02 _{hex} Out1 = 4600 _{hex} | Configuration for channel 7 |
| 16 | Wait until In1 = Out1 | Wait for confirmation |
| 17 | Out2 = 000F _{hex} Out1 = 4700 _{hex} | Configuration for channel 8 |
| 18 | Wait until In1 = Out1 | Wait for confirmation |
| 19 | Wait 4 seconds | Wait until all channels have settled |
| 20 | Out1 = 0800 _{hex} | Request measured values of channels 1 - 4 |
| 21 | Wait until In1 = Out1 | Wait for confirmation |

| Step No. | Process data | Configuration |
|----------|--------------------------------------------------------------------------------------------------------------------------------------|-------------------------------------------|
| 22 | Measured value channel 1 = In2 Measured value channel 2 = In3 Measured value channel 3 = In4 Measured value channel 4 = In5 | Read measured values of channels 1 - 4 |
| 23 | Out1 = 0900 _{hex} | Request measured values of channels 5 - 8 |
| 24 | Wait until In1 = Out1 | Wait for confirmation |
| 25 | Measured value channel 5 = In2 Measured value channel 6 = In3 Measured value channel 7 = In4 Measured value channel 8 = In5 | Read measured values of channels 5 - 8 |

24 Notes on diagnostic behavior in the event of an error



The diagnostic system detects and reports single interrupted sensor wires or multiple interrupted sensor wires as well as completely disconnected sensor cables, see sections 24.1 to 24.4.

24.1 Diagnostic behavior in the event of an error with ODS = 0 or ODS = 1

The following error states are detected and indicated by the terminal itself. The errors are partly represented via the process input data and/or the corresponding diagnostic LEDs on the module.

| No. | Malfunction/error | Indication in the process data or other messages | Diagnostic and status indicators |
|-----|----------------------------------------------------------------------------------------|-------------------------------------------------------------------------------------------------------------------|---------------------------------------------------------------|
| 1 | U_L (7.5 V) missing | None, bus error | No LED is ON. |
| 2 | Measured value is above the valid measuring range (e.g., 500 Ω at Pt100 input). | 8001 _{hex} , overrange Error bit set in the first process data input word. | The LED of the relevant channel (1 ... 8) is red. |
| 3 | Sensor connector is not plugged in and/or the sensor cable is completely interrupted. | 8002 _{hex} , open circuit Error bit set in the first process data input word. | The LED of the relevant channel (1 ... 8) is red. |
| 4 | Measured value invalid (e.g., during the reconfiguration of a channel). | 8004 _{hex} , measured value invalid Error bit set in the first process data input word. | The LED of the relevant channel (1 ... 8) is temporarily red. |
| 5 | U_{ANA} (+24 V) is missing or failure of internal I/O voltages. | I/O error message is triggered. | The D LED is green and flashes at 2 Hz. |
| 6 | Internal component faulty. | 8040 _{hex} , self diagnostics Component error and error bit set in the first process data input word. | |
| 7 | Measured value is below the valid measuring range (e.g., 5 Ω at Pt100 input). | 8080 _{hex} , underrange Error bit set in the first process data input word. | The LED of the relevant channel (1 ... 8) is temporarily red. |

24.2 Diagnostic behavior in the event of an error with ODS = 3

For applications with particularly high EMC requirements (significantly higher than the standardized limit values) the ODS function can be set to value 3. This deactivates the open circuit detection function and allows for error-free measurements even under particularly high EMI conditions.

| Malfunction/error | Indication in the process data or other messages | Diagnostic and status indication |
|---------------------------------------------------------------------------------------|----------------------------------------------------------------------------------------|---------------------------------------------------|
| Sensor connector is not plugged in and/or the sensor cable is completely interrupted. | 8001 _{hex} , overrange Error bit set in the first process data input word. | The LED of the relevant channel (1 ... 8) is red. |

24.3 Diagnostics response times in the event of an open circuit

The following table lists the typical diagnostics response times if the sensor connector is not plugged in and/or the sensor cable is completely interrupted.

| Settings for ODS (open circuit detection sensitivity) | Settings recommended for | Diagnostic message in the process data | Typical response time of all eight channels |
|-------------------------------------------------------|-------------------------------------------------------------------------------|----------------------------------------|---------------------------------------------|
| 0 _{hex} / High sensitivity | Interference coupling within the standardized level | 8002 _{hex} (open circuit) | 2 s ... 5 s |
| 1 _{hex} / Medium sensitivity | Interference coupling slightly above the standardized level | 8002 _{hex} (open circuit) | 6 s |
| 3 _{hex} / OFF | Interference coupling significantly higher than the standardized level | 8001 _{hex} (overrange) | 15 s ... 17 s |



The typical response time of the diagnostic messages was determined between the error event and the message in the process data. The time also includes transmission of the data to the control system/controller board in the test system used.

24.4 Diagnostics response times if single sensor wires are interrupted

The following table lists the typical diagnostics response times if single sensor wires are interrupted.

| Settings for ODS (open circuit detection sensitivity) | Settings recommended for | Diagnostic message in the process data | Typical response time of all eight channels |
|-------------------------------------------------------|-------------------------------------------------------------------------------|------------------------------------------------------------------------|---------------------------------------------|
| 0 _{hex} / High sensitivity | Interference coupling within the standardized level | 8002 _{hex} (open circuit) or 8080 _{hex} (underrange) | 2 s ... 5 s |
| 1 _{hex} / Medium sensitivity | Interference coupling slightly above the standardized level | 8002 _{hex} (open circuit) or 8080 _{hex} (underrange) | 2 s ... 5 s |
| 3 _{hex} / OFF (see note below the table) | Interference coupling significantly higher than the standardized level | 8001 _{hex} (overrange) or 8080 _{hex} (underrange) | 2 s ... 60 s |



CAUTION:

In the event of an ODS = 3 configuration:

Please note that the response time of the diagnostic message can be up to 60 seconds longer in your application if a single wire is broken.

During this time the measured values are either rising or falling.



Компания «ЭлектроПласт» предлагает заключение долгосрочных отношений при поставках импортных электронных компонентов на взаимовыгодных условиях!

Наши преимущества:

- Оперативные поставки широкого спектра электронных компонентов отечественного и импортного производства напрямую от производителей и с крупнейших мировых складов;
- Поставка более 17-ти миллионов наименований электронных компонентов;
- Поставка сложных, дефицитных, либо снятых с производства позиций;
- Оперативные сроки поставки под заказ (от 5 рабочих дней);
- Экспресс доставка в любую точку России;
- Техническая поддержка проекта, помощь в подборе аналогов, поставка прототипов;
- Система менеджмента качества сертифицирована по Международному стандарту ISO 9001;
- Лицензия ФСБ на осуществление работ с использованием сведений, составляющих государственную тайну;
- Поставка специализированных компонентов (Xilinx, Altera, Analog Devices, Intersil, Interpoint, Microsemi, Aeroflex, Peregrine, Syfer, Eurofarad, Texas Instrument, Miteq, Cobham, E2V, MA-COM, Hittite, Mini-Circuits, General Dynamics и др.);

Помимо этого, одним из направлений компании «ЭлектроПласт» является направление «Источники питания». Мы предлагаем Вам помощь Конструкторского отдела:

- Подбор оптимального решения, техническое обоснование при выборе компонента;
- Подбор аналогов;
- Консультации по применению компонента;
- Поставка образцов и прототипов;
- Техническая поддержка проекта;
- Защита от снятия компонента с производства.



Как с нами связаться

Телефон: 8 (812) 309 58 32 (многоканальный)

Факс: 8 (812) 320-02-42

Электронная почта: org@eplast1.ru

Адрес: 198099, г. Санкт-Петербург, ул. Калинина, дом 2, корпус 4, литера А.