



Features

- Long life carbon element
- Assortment of resistance tapers
- 60 and 100 mm travel lengths
- Touch sense lever
- PC terminals or snap-in connector option



PSM Series Motorized Slide Potentiometer

Electrical Characteristics

Standard Resistance Range
 1K ohms to 1 megohm
 Standard Resistance Tolerance... ±20 %
 End Resistance 20 ohms max.
 Insulation Resistance @ 250 VDC
 100 megohms min.
 Dielectric Withstanding Voltage
 250 VAC
 Standard Taper Linear, Audio
 Power Rating - Linear 0.5 watt
 Power Rating - Audio 0.25 watt
 Slider Noise 47 mV max.
 Touch Sense Track
 Conductive Resistance
 Snap-in Connector..... 2 ohms max.
 PC Terminal
 TR > 30k ohms...0.1 % of TR max.
 TR ≤ 30k ohms..... 30 ohms max.

Environmental Characteristics

Operational Life 100,000 cycles
 TR Shift ±15 %
 Operating Temperature Range
 -10 °C to +55 °C
 Resistance to Solder Heat..... ±5 %

Mechanical Characteristics

Mechanical Travel
 See Product Dimensions
 Operating Force
 100 mm Travel..... 30-130 gf
 60 mm Travel..... 10-110 gf
 Stop Strength 5 kgf min.
 Shaft Wobble
 100 mm Travel..... 1.3 mm p-p max.
 60 mm Travel..... 1.6 mm p-p max.
 Soldering Condition
 Manual 350 °C ±5 °C for 3 sec.
 Wave 260 °C ±5 °C for 5 sec.
 Wash Not recommended

Motor Drive Characteristics

Rated Voltage 10 VDC
 Operating Voltage Supply .. 6 to 11 VDC
 Starting Current 800 mA max.
 Lever Speed @ 10 VDC
 20 mm/0.1 sec.

Product Dimensions

PC Terminals - 100 mm Travel

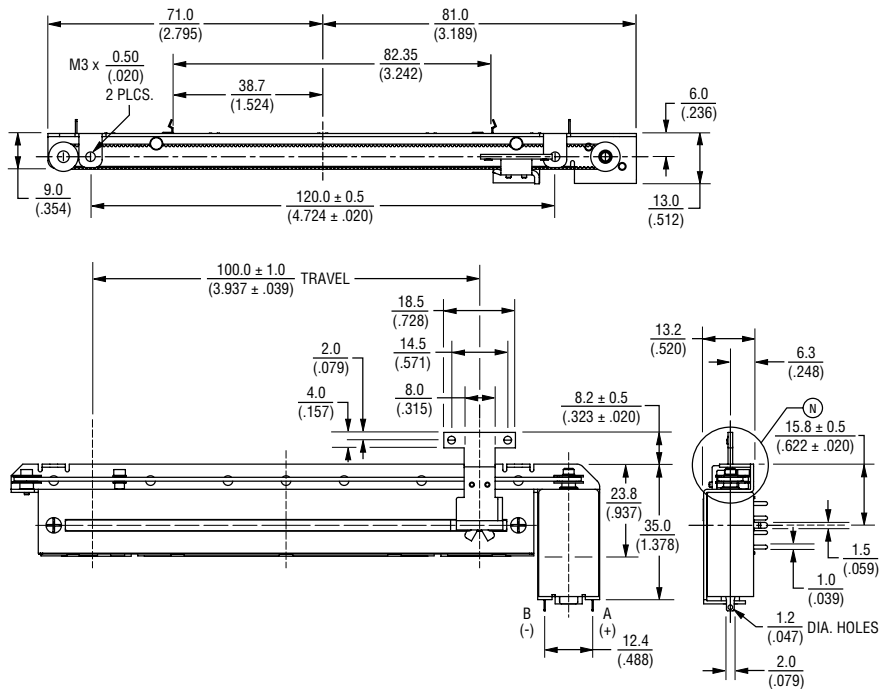

Mounting Hole Detail

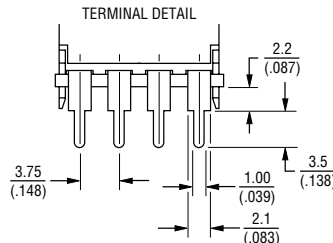
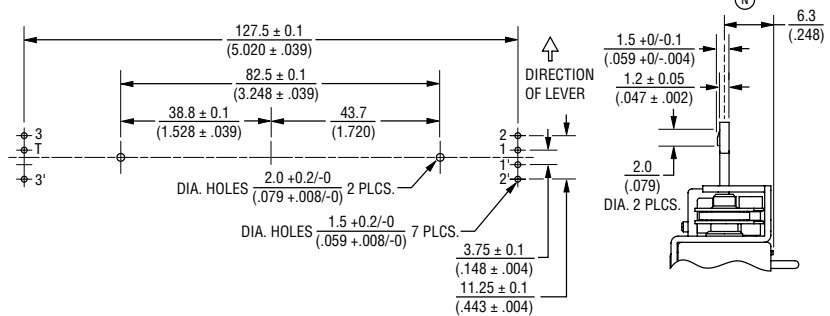

DIMENSIONS: $\frac{\text{MM}}{\text{(INCHES)}}$

*RoHS Directive 2002/95/EC Jan. 27, 2003 including annex and RoHS Recast 2011/65/EU June 8, 2011.
 Specifications are subject to change without notice.
 The device characteristics and parameters in this data sheet can and do vary in different applications and actual device performance may vary over time.
 Users should verify actual device performance in their specific applications.

Applications

- Audio mixing consoles
- Broadcast mixing consoles

PSM Series Motorized Slide Potentiometer

BOURNS®

Product Dimensions

PC Terminals - 60 mm Travel

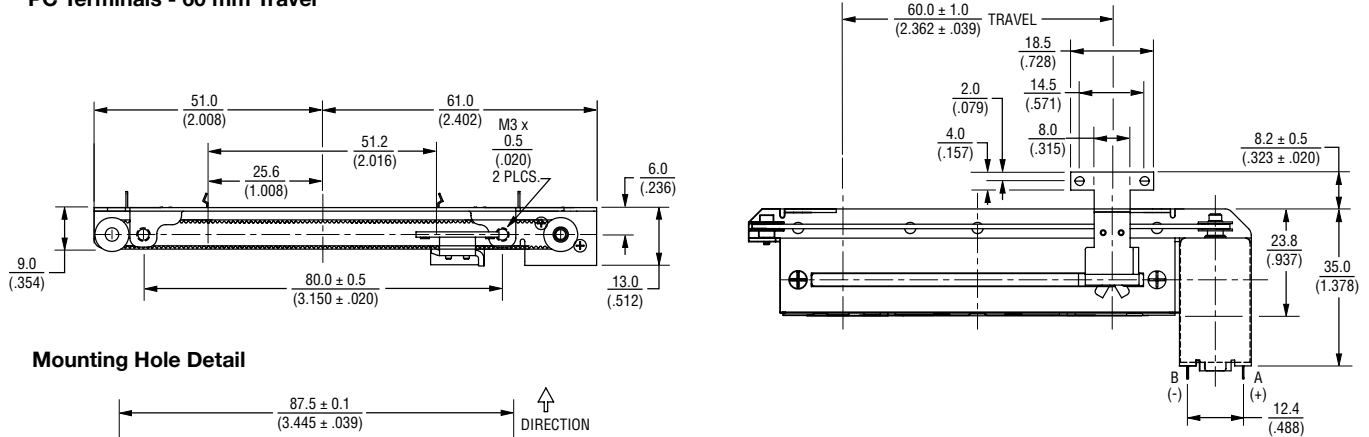

Snap-in Connector - 100 mm Travel

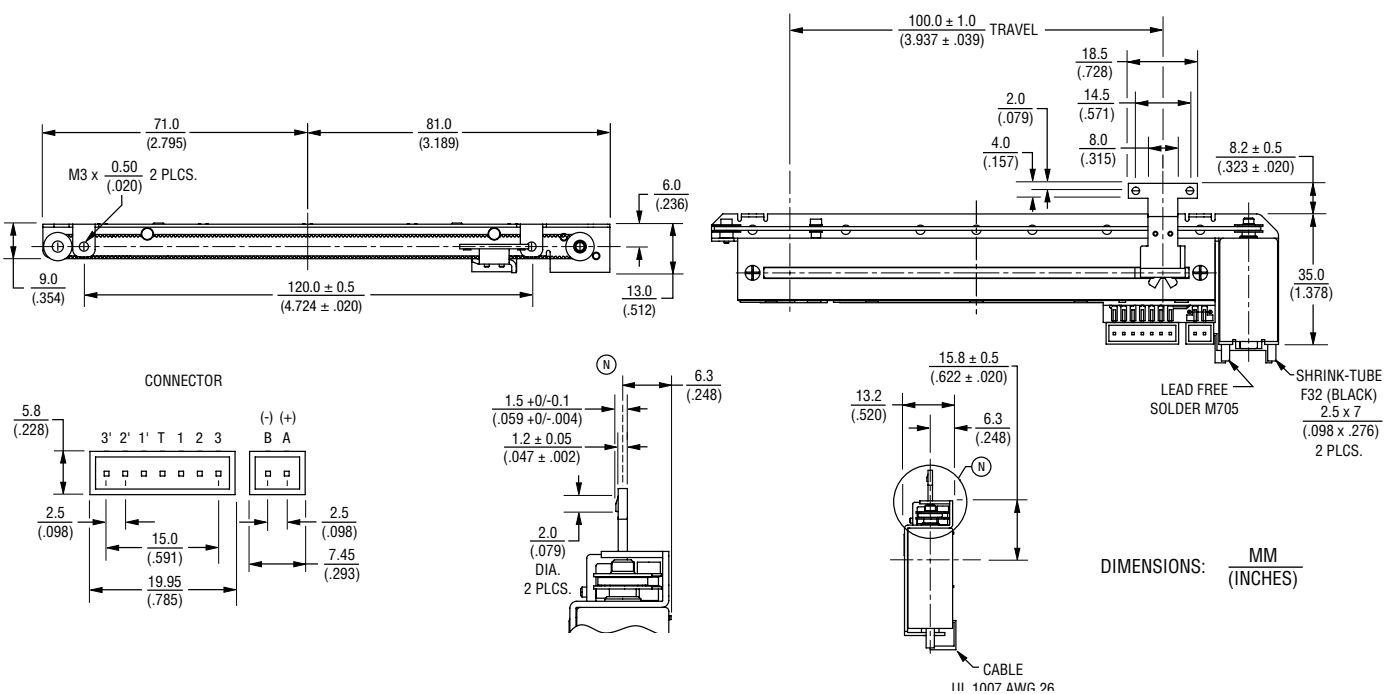

Specifications are subject to change without notice.
The device characteristics and parameters in this data sheet can and do vary in different applications and actual device performance may vary over time.
Users should verify actual device performance in their specific applications.

PSM Series Motorized Slide Potentiometer

BOURNS®

Product Dimensions

Snap-in Connector - 60 mm Travel

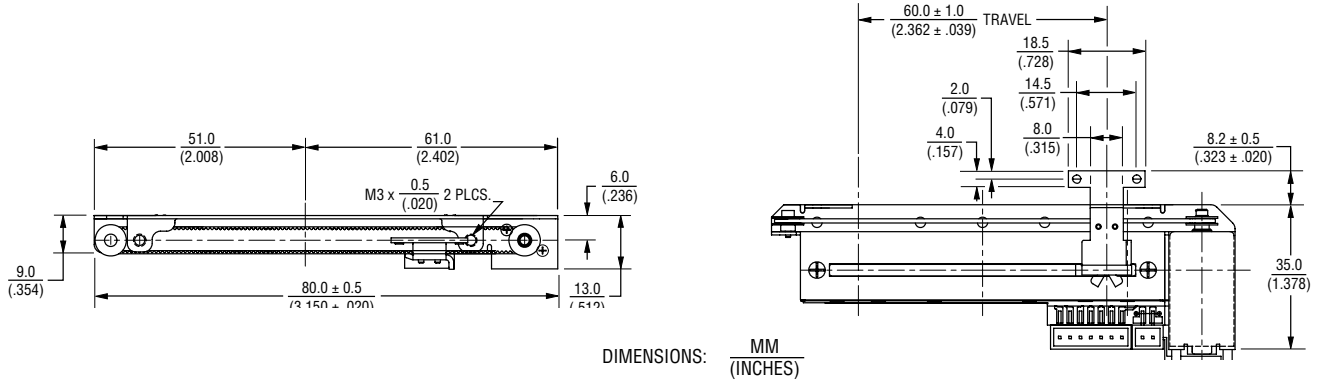

Schematics

Motor

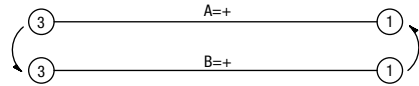
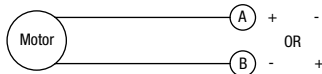

Line Track (R1)



Servo Track (R2)

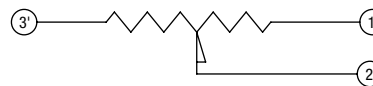

Touch Sense Track

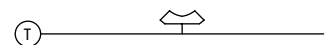

Standard Resistance Table

Resistance (Ohms)	Resistance Code
1,000	102
2,000	202
5,000	502
10,000	103
20,000	203
50,000	503
100,000	104
200,000	204
500,000	504
1,000,000	105

How To Order

PSM 01 - 08 2 A - 103 B2

Model Number _____

Designator _____
PSM = Motorized Slide Potentiometer

Length of Travel _____
01 = 100 mm
60 = 60 mm

Lever Length _____
08 = 8.2 mm

Terminal Type _____
1 = PC Terminals
2 = Snap-in Connector

Lever End Style _____
A = Metal Lever (Refer to Drawing)

Resistance Code _____
(See Standard Resistance Table)

Resistance Taper (See Taper Charts) _____
Taper Series followed by Curve Number

Servo Track Output Chart

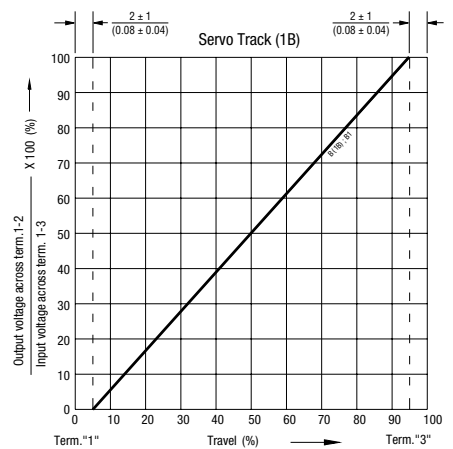

Specifications are subject to change without notice.

The device characteristics and parameters in this data sheet can and do vary in different applications and actual device performance may vary over time. Users should verify actual device performance in their specific applications.

PSM Series Motorized Slide Potentiometer

BOURNS®

Tapers

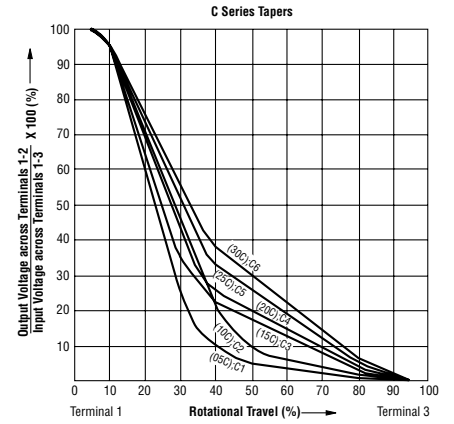
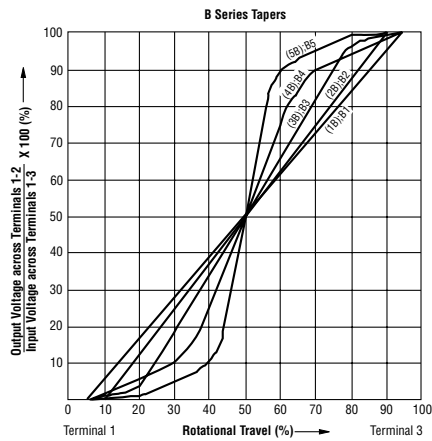
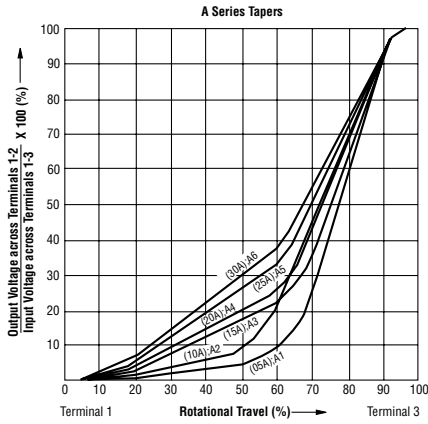

BOURNS®

Asia-Pacific: Tel: +886-2 2562-4117 • Fax: +886-2 2562-4116

EMEA: Tel: +36 88 520 390 • Fax: +36 88 520 211

The Americas: Tel: +1-951 781-5500 • Fax: +1-951 781-5700

www.bourns.com

REV. 01/16

Specifications are subject to change without notice.
The device characteristics and parameters in this data sheet can and do vary in different applications and actual device performance may vary over time.
Users should verify actual device performance in their specific applications.



Компания «ЭлектроПласт» предлагает заключение долгосрочных отношений при поставках импортных электронных компонентов на взаимовыгодных условиях!

Наши преимущества:

- Оперативные поставки широкого спектра электронных компонентов отечественного и импортного производства напрямую от производителей и с крупнейших мировых складов;
- Поставка более 17-ти миллионов наименований электронных компонентов;
- Поставка сложных, дефицитных, либо снятых с производства позиций;
- Оперативные сроки поставки под заказ (от 5 рабочих дней);
- Экспресс доставка в любую точку России;
- Техническая поддержка проекта, помощь в подборе аналогов, поставка прототипов;
- Система менеджмента качества сертифицирована по Международному стандарту ISO 9001;
- Лицензия ФСБ на осуществление работ с использованием сведений, составляющих государственную тайну;
- Поставка специализированных компонентов (Xilinx, Altera, Analog Devices, Intersil, Interpoint, Microsemi, Aeroflex, Peregrine, Syfer, Eurofarad, Texas Instrument, Miteq, Cobham, E2V, MA-COM, Hittite, Mini-Circuits, General Dynamics и др.);

Помимо этого, одним из направлений компании «ЭлектроПласт» является направление «Источники питания». Мы предлагаем Вам помощь Конструкторского отдела:

- Подбор оптимального решения, техническое обоснование при выборе компонента;
- Подбор аналогов;
- Консультации по применению компонента;
- Поставка образцов и прототипов;
- Техническая поддержка проекта;
- Защита от снятия компонента с производства.



Как с нами связаться

Телефон: 8 (812) 309 58 32 (многоканальный)

Факс: 8 (812) 320-02-42

Электронная почта: org@eplast1.ru

Адрес: 198099, г. Санкт-Петербург, ул. Калинина, дом 2, корпус 4, литера А.