

# General Specifications

Toggles

Rockers  
B

Pushbuttons

Illuminated PB

Programmable

Keylocks

Rotaries

Slides

Tactiles

Tilt

Touch

Indicators

Accessories

Supplement

## Electrical Capacity (Resistive Load)

**Power Level:** 9A @ 125V AC or 6A @ 250V AC

## Other Ratings

**Contact Resistance:** 20 milliohms maximum

**Insulation Resistance:** 500 megohms minimum @ 500V DC

**Dielectric Strength:** 1,500V AC minimum between contacts for 1 minute minimum;  
3,000V AC minimum between contacts & case for 1 minute minimum

**Mechanical Life:** 30,000 operations minimum

**Electrical Life:** 10,000 operations minimum

**Nominal Operating Force:** Single Pole 4.50N; Double Pole 10.0N

**Angle of Throw:** 33°

## Materials & Finishes

**Rocker:** Polycarbonate

**Housing:** Polyamide

**Movable Contactor:** Beryllium copper with silver plating

**Movable Contacts:** Silver alloy

**Stationary Contacts:** Silver alloy

**Switch Terminals:** Brass with silver plating

**Lamp Terminals:** Brass with silver plating

## Environmental Data

**Operating Temp Range:** -10°C through +50°C (+14°F through +122°F)

**Humidity:** 90 ~ 95% humidity for 96 hours @ 40°C (104°F)

**Vibration:** 10 ~ 55Hz with peak-to-peak amplitude of 1.5mm traversing the frequency range & returning in 1 minute; 3 right angled directions for 2 hours

**Shock:** 50G (490m/s<sup>2</sup>) acceleration (tested in 6 right angled directions, with 5 shocks in each direction)

## Installation

**Soldering Time & Temp:** Manual Soldering: See Profile A in Supplement section.

## Standards & Certifications

**UL:** File No. E44145

All models recognized at 9A @ 125V AC & 6A @ 250V AC.  
cULus marking on case is standard.

# Distinctive Characteristics

Full face, bright LED illumination in choice of red, amber, or green for visible status indication.

9-amp or 6-amp electrical capacity in compact body.

Interior shield prevents contamination of the rocker by carbon from arcing.

Front panel, snap-in mounting assures labor-saving installation.

Single-break, snap-acting contact mechanism gives smooth actuation and audible feedback.

Quick-make, quick-break characteristic limits arcing and prolongs electrical life.

Stable stationary contact construction for high reliability.

Offset terminal alignment gives outstanding insulation resistance and dielectric strength.

Solder lug/.110" quick connect terminals can be used with connectors.



Actual Size

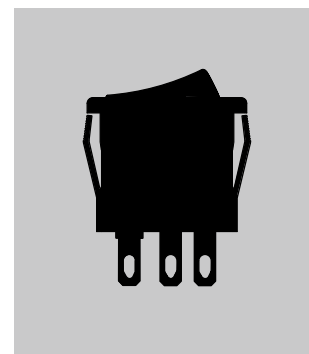

### TYPICAL SWITCH ORDERING EXAMPLE

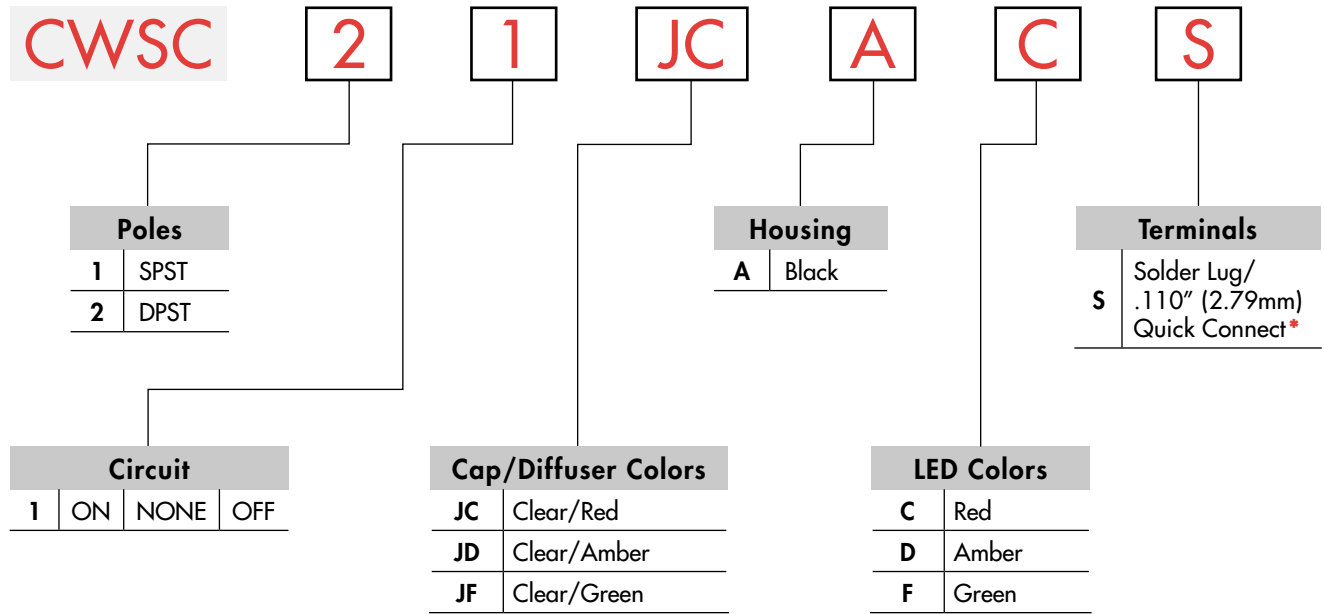

\* Wire harness & cable assemblies offered only in Americas

### TYPICAL ORDERING EXAMPLE

**CWSC21JCACS**

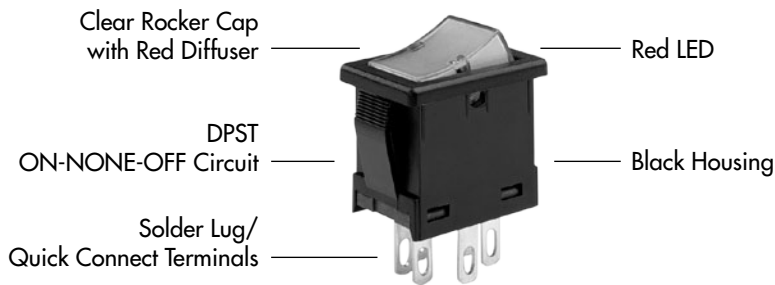



### IMPORTANT:



Switches are supplied with cULus marking on case. Specific models & ratings noted on General Specifications page.

## POLE & CIRCUITS

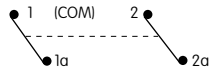
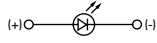
Pole	Model	Rocker Position			Connected Terminals			Throw & Switch/Lamp Schematics
		Down	Center	Up	Down	Center	Up	
SP	CWSC11	ON	NONE	OFF	1-1a	OPEN	OPEN	Notes: Terminal numbers and polarity are actually on the switch. SPST  
DP	CWSC21	ON	NONE	OFF	1-1a 2-2a	OPEN	OPEN	DPST  

## CAP TYPES & COLORS

### Rocker Cap/Diffuser

Caps are factory assembled and are not available separately.



### Cap/Diffuser Colors Available

- JC** Clear/Red
- JD** Clear/Amber
- JF** Clear/Green

## HOUSING

- A** Black Housing with Snap-in Mounting

On Off (I O) symbols are molded on the bezel.



## TERMINALS

- S** Solder Lug/.110" (2.79mm) Quick Connect

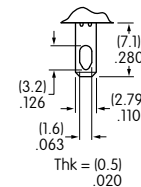

## LED SPECIFICATIONS & COLORS

The LED is factory assembled and not available separately. LED circuit is isolated and requires an external power source. Polarity marks are on the bottom of the switch.

The electrical specifications shown are determined at a basic temperature of 25°C.

If the source voltage exceeds the rated voltage, a ballast resistor is required. The resistor value can be calculated by using the formula in the Supplement.

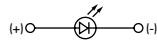
		<b>C</b> Red	<b>D</b> Amber	<b>F</b> Green
 Colors:				
Forward Peak Current	$I_{FM}$	30mA	30mA	30mA
Typical Forward Current	$I_F$	20mA	20mA	20mA
Forward Voltage	$V_F$	1.95V	2.0V	2.1V
Reverse Peak Voltage	$V_{RM}$	5V	5V	5V
Current Reduction Rate above 25°C	$\Delta I_F$	0.41mA/°C	0.29mA/°C	0.39mA/°C
Ambient Temperature Range		-10°C ~ +50°C		

### TYPICAL SWITCH DIMENSIONS

#### LED Illuminated

#### Single Pole

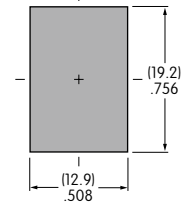
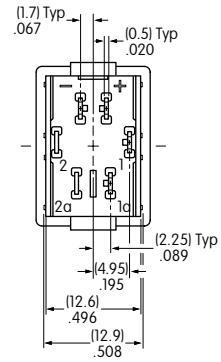
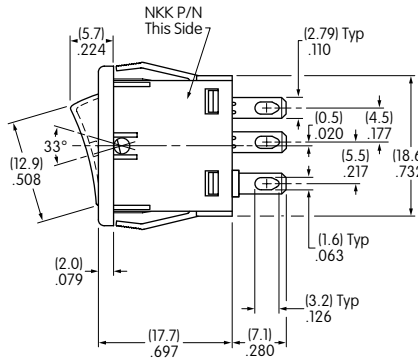
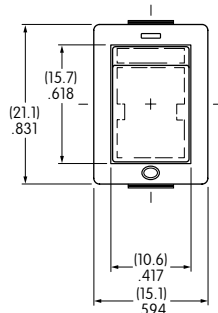

**CWSC11JCACS**

Panel Thickness  
.030" ~ .079"  
(0.75mm ~ 2.0mm)

#### LED Illuminated

#### Double Pole

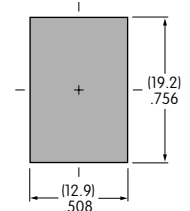
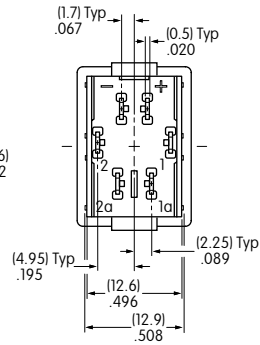
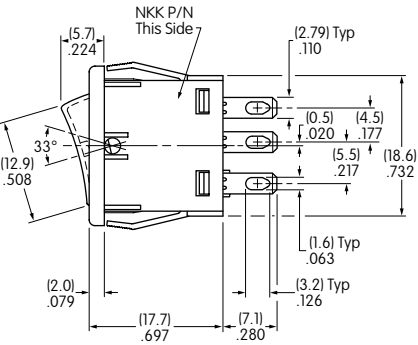
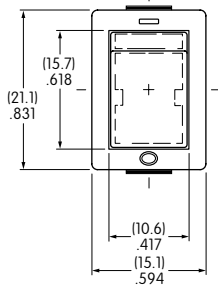

**CWSC21JCACS**

Panel Thickness  
.030" ~ .079"  
(0.75mm ~ 2.0mm)

Toggles

Rockers  
**B**

Pushbuttons

Illuminated PB

Programmable

Keylocks

Rotaries

Slides

Tactiles

Tilt

Touch

Indicators

Accessories

Supplement



Компания «ЭлектроПласт» предлагает заключение долгосрочных отношений при поставках импортных электронных компонентов на взаимовыгодных условиях!

Наши преимущества:

- Оперативные поставки широкого спектра электронных компонентов отечественного и импортного производства напрямую от производителей и с крупнейших мировых складов;
- Поставка более 17-ти миллионов наименований электронных компонентов;
- Поставка сложных, дефицитных, либо снятых с производства позиций;
- Оперативные сроки поставки под заказ (от 5 рабочих дней);
- Экспресс доставка в любую точку России;
- Техническая поддержка проекта, помощь в подборе аналогов, поставка прототипов;
- Система менеджмента качества сертифицирована по Международному стандарту ISO 9001;
- Лицензия ФСБ на осуществление работ с использованием сведений, составляющих государственную тайну;
- Поставка специализированных компонентов (Xilinx, Altera, Analog Devices, Intersil, Interpoint, Microsemi, Aeroflex, Peregrine, Syfer, Eurofarad, Texas Instrument, Miteq, Cobham, E2V, MA-COM, Hittite, Mini-Circuits, General Dynamics и др.);

Помимо этого, одним из направлений компании «ЭлектроПласт» является направление «Источники питания». Мы предлагаем Вам помощь Конструкторского отдела:

- Подбор оптимального решения, техническое обоснование при выборе компонента;
- Подбор аналогов;
- Консультации по применению компонента;
- Поставка образцов и прототипов;
- Техническая поддержка проекта;
- Защита от снятия компонента с производства.



#### Как с нами связаться

**Телефон:** 8 (812) 309 58 32 (многоканальный)

**Факс:** 8 (812) 320-02-42

**Электронная почта:** [org@eplast1.ru](mailto:org@eplast1.ru)

**Адрес:** 198099, г. Санкт-Петербург, ул. Калинина, дом 2, корпус 4, литера А.