

# Amphenol Connex

Broadcast  
Solutions



**Broadcast Solutions**

**Amphenol Connex** is an industry leading supplier of RF connectors, cable assemblies and adapters servicing a diverse customer base worldwide. Our high-quality, yet cost effective 75 ohm BNC and 1.0/2.3 DIN product range is ideal for high performance broadcast video applications requiring data transfer rates of 3 Gb/s or more. Standard off-the-shelf solutions are available from inventory and custom solutions can be developed, sampled and proven within just a few short weeks.

**Contact us today for your next Broadcast Solution.**



**Amphenol Connex  
Corporation:**

**Uncompromised Quality,  
Vast Selection, Superb  
Technical Support**

## Amphenol Connex

---

5069 Maureen Lane, Unit B  
Moorpark, CA 93021 USA  
805.378.6464  
800.942.6639  
[www.amphenolconnex.com](http://www.amphenolconnex.com)

---

Copyright 2011 Amphenol Connex Corporation. All Rights Reserved.

The content of this brochure must not be used in any form or manner without prior approval in writing. The names, logos and text within this document are protected by intellectual property law, fair trading and other laws. We reserve the right to modify designs and/or specifications in order to improve quality, keep pace with technological advances, or to meet particular requirements in production. We periodically review content and check for inaccuracies. Nevertheless, the contents are solely for information and are not to be construed as an offer, a warranty, an implied warranty or a contractual commitment of any kind.



The BNC product line is a miniature, quick connect/disconnect RF connector. It features two bayonet lugs on the female connector, and locking is achieved with a quick quarter-turn of the coupling nut.

BNCs are ideally suited for cable termination of miniature and subminiature coaxial cable. BNCs are designed to accommodate a large variety of industry-standard cables, including all standard 75 Ohm broadcast video cables offered by popular manufacturers.

Our BNC product line includes cable mount connectors with crimp attachments, PCB mount and panel mount / bulkhead receptacles, adapters, terminators, and tooling.

**Features & Benefits**

- Industry standard for over 50 years
- Innovative bayonet coupling system ensures positive locking and allows quick and easy mating and un-mating of connectors
- True 75 ohm connectors are designed to meet SMPTE return loss requirements
- Durable high temperature PTFE insulators and low-cost Delrin dielectrics are available
- Broad product line. Many options and features available with stock available.

**Common Applications**

- High performance broadcast applications including video routing and distribution, content management and storage.
- Instrumentation and test applications



**ELECTRICAL SPECIFICATIONS**

Impedance	75 Ohms
Frequency Range	0 to 4 GHz
Working Voltage	500 Volts
Dielectric Withstanding Voltage	1500 Volts
VSWR	Typically 1.15:1 or better at 3 Ghz. Contact the factory
Contact Resistance	Center Contact: 1.5 Milliohms Max
	Outer Contact: 1.0 Milliohms Max
Insulation Resistance	5000 Megohms Min

**MATERIAL SPECIFICATIONS**

Component	Material	Finish
Center Contact – Male	Brass Alloy	Gold
Center Contact – Female	Beryllium Copper or Phosphor Bronze	Gold
Coupling Nut and Body	Brass or Zinc Die Cast	Nickel or Gold
Dielectric	PTFE or Delrin	Natural
Gaskets	Silicone Rubber	Red
Crimp Ferrule	Annealed Copper	Nickel

# BNC CONNECTORS

## CABLE GROUP LEGEND

01	58/ 58A/ 58C/ 141/ 303/ LMR195™/ B7806A	06A	179/ U DOUBLE BRAIDED	11	.085 SEMI-RIGID/ 405/U
01A	55/ 142/ 223/ 400	07	8/ 8A/ 213/ 393	12	.250 SEMI-RIGID
01B	LMR200™/ B7807A	07A	214/ 225	13	.047 SEMI-RIGID/ B1674A
01C	LMR300™/ B7809A	07B	8X/ LMR240™/ B7808A	14	178/ 196
02	58 PLENUM/ THINNET/ 122U/ B88240/ B89907	07C	B9913/ LMR400™/ B7810A/ B8214	15	B8281/ B9231/ B9141
03	59/ 62/ 140/ 210	07D	B89913	15A	B88281
03A	59/ U-20AWG/ B1505	07E	11	16	180/ 195/ 122/ B8218/ B1865A/ B1855
04	59/ U PLENUM/ B9108/ B9104	07F	11/ U-14AWG/ B8213/ B9292/ B7731/ B1859A	17	LMR600™
04A	59/ U PLENUM-20AWG	08	6/ U B3093A QUADSHIELD	18	AT&T734A/ B1505A/ B9145
05	174/ 188A/ 316/ B7805A/ LMR100™	08A	B1694A/ B9248/ B3093A QUAD SHIELD	19	AT&T735A/ B735A1
05A	316/ U DOUBLE BRAIDED	08B	6 PLENUM/ B1695A/ B89248	20	AMC 1.13mm cable
06	179/ 187/ B9221	09	B8227/ 89207	21	AMC 1.32mm cable
		10	.141 SEMI-RIGID/ 402/U	22	AMC 1.37mm cable

## PCB MOUNT, VERTICAL RECEPTACLE

P.N.	Cable Group	Finish	Insulation	Impedance	Crimp Tool	Notes
112515-75	N/A	Nickel	PTFE	75	N/A	4-Legs, 0.788 Inch Profile
112405	N/A	Nickel	PTFE	75	N/A	4-Legs, 0.638 Inch Profile
112586	N/A	Nickel	PTFE	75	N/A	4-Legs, 0.737 Inch Profile, Small Footprint
112586-13	N/A	Nickel	PTFE	75	N/A	3-Legs, 0.737 Inch Profile, Small Footprint



112515-75

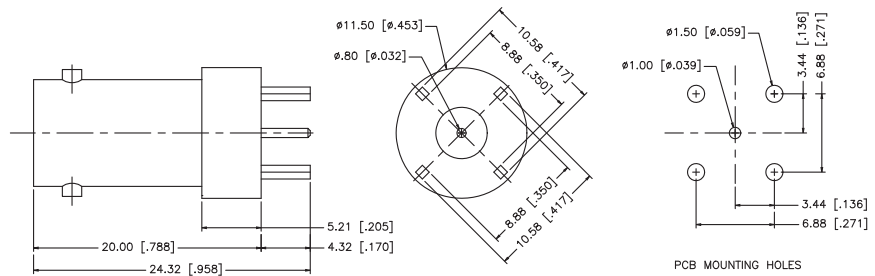

112586

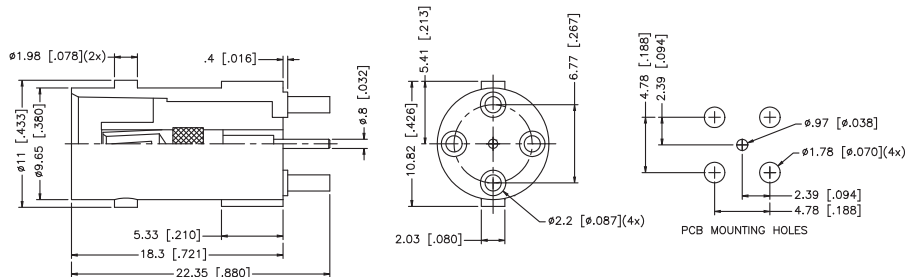

# BNC CONNECTORS

## PCB MOUNT, RIGHT ANGLE RECEPTACLE

P.N.	Cable Group	Finish	Insulation	Impedance	Crimp Tool	Notes
112778	N/A	Nickel	PTFE	75	N/A	Standard Profile with Through-Hole Center Contact

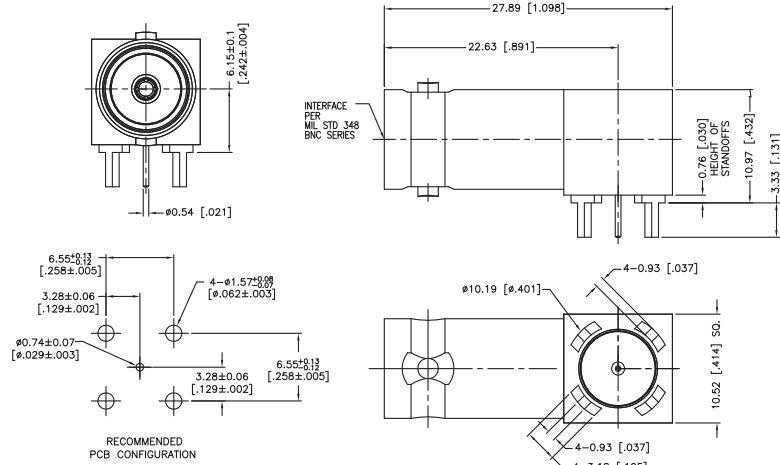

## PCB MOUNT, RIGHT ANGLE BULKHEAD RECEPTACLE

P.N.	Cable Group	Finish	Insulation	Impedance	Crimp Tool	Notes
112659-75-12	N/A	Nickel	PTFE	75	N/A	Low Profile with SMT Center Contact
112800	N/A	Nickel	PTFE	75	N/A	High Profile with SMT Center Contact
112804	N/A	Nickel	PTFE	75	N/A	High Profile with Through-Hole Center Contact
112809-75	N/A	Nickel/Tin	PTFE	75	N/A	Standard Profile with Through-Hole Center Contact

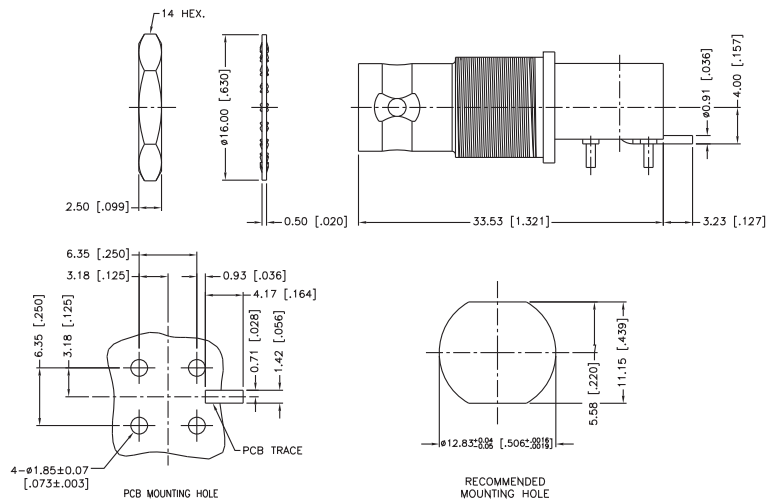

# BNC CONNECTORS

## PCB MOUNT, END LAUNCH BULKHEAD RECEPTACLE

P.N.	Cable Group	Finish	Insulation	Impedance	Crimp Tool	Notes
112740-13	N/A	Gold	PTFE	75	N/A	for 0.062 Inch Thick PCB
112740-16	N/A	Gold	PTFE	75	N/A	for 0.084 Inch Thick PCB
112806-75	N/A	Gold	PTFE	75	N/A	for 0.062 Inch Thick PCB, Isolated

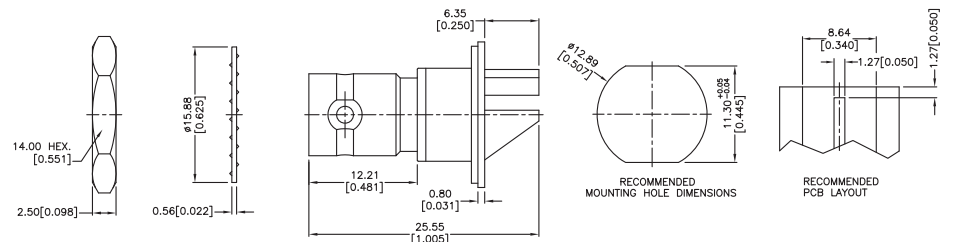
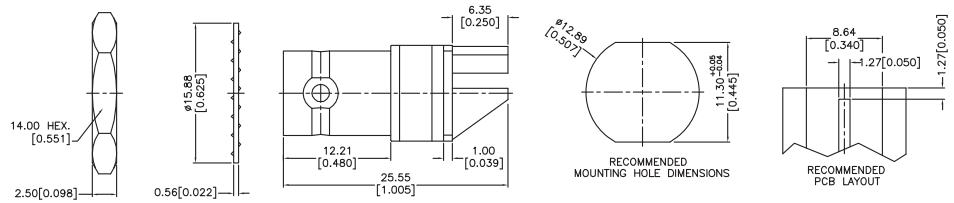

## PCB MOUNT, END LAUNCH BULKHEAD RECEPTACLE WITH PCB LOCKS

P.N.	Cable Group	Finish	Insulation	Impedance	Crimp Tool	Notes
112775-75	N/A	Nickel	PTFE	75	N/A	for 0.062 Inch Thick PCB with PCB Clips

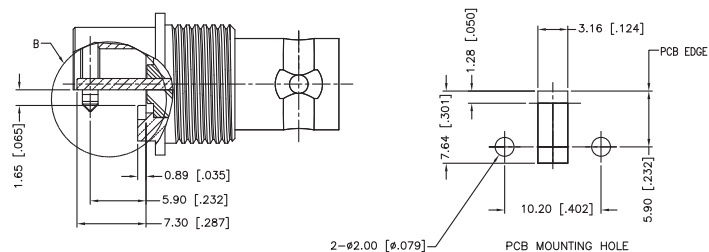

# BNC CONNECTORS

## PCB MOUNT, END LAUNCH RECEPTACLE

P.N.	Cable Group	Finish	Insulation	Impedance	Crimp Tool	Notes
112801	N/A	Gold	PTFE	75	N/A	for 0.062 Inch Thick PCB
112641	N/A	Nickel	PTFE	75	N/A	for 0.062 Inch Thick PCB

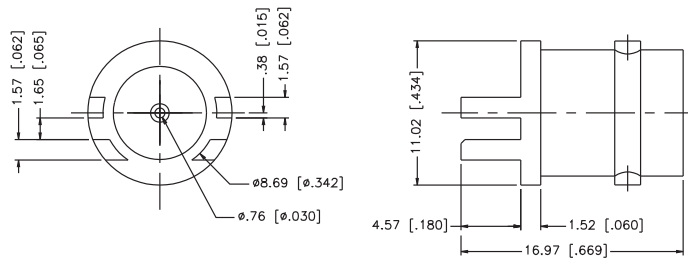
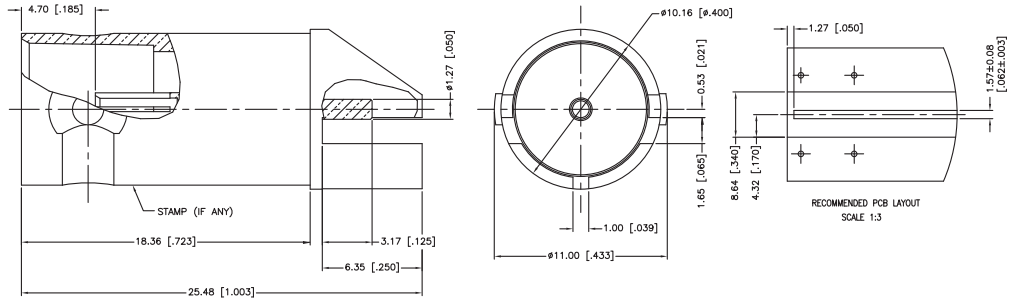

## PCB MOUNT, END LAUNCH BULKHEAD PLUG, PUSH-ON

P.N.	Cable Group	Finish	Insulation	Impedance	Crimp Tool	Notes
112770-10	N/A	Nickel	PTFE	75	N/A	for 0.062 Inch Thick PCB

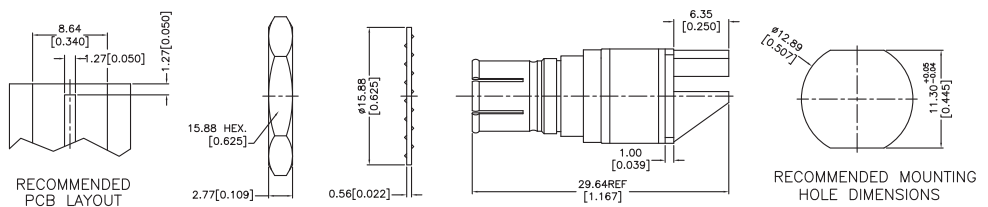

# BNC CONNECTORS

## CABLE MOUNT, STRAIGHT PLUGS

P.N.	Cable Group	Finish	Insulation	Impedance	Crimp Tool	Notes
112952	03	Nickel	PTFE	75	47-10110	
112956	03A	Nickel	PTFE	75	47-10110	
112957	08A	Nickel	PTFE	75	47-10110	
112958	08B	Nickel	PTFE	75	47-10110	
112955	16	Nickel	PTFE	75	47-10120	
112950	19	Nickel	PTFE	75	47-10120	
112951	18	Nickel	PTFE	75	47-10110	
112983	15	Nickel	PTFE	75	47-10110	
112981	-	Nickel	PTFE	75	47-10110	for B1794A
112954	06	Nickel	PTFE	75	47-10120	
112954-10	06	Nickel	PTFE	75	47-10120	
112491-10	-	Nickel	PTFE	75	47-10150	for 100 MHz RGB Cable
112975	04	Nickel	PTFE	75	47-10110	



112954-10

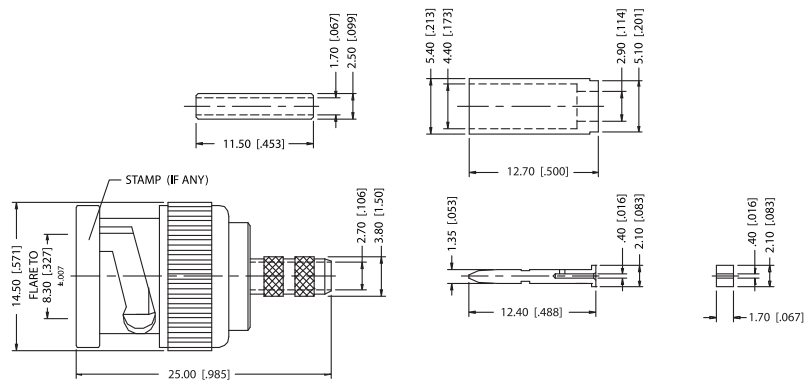

## CABLE MOUNT, RIGHT ANGLE PLUGS

P.N.	Cable Group	Finish	Insulation	Impedance	Crimp Tool	Notes
112960	03	Nickel	PTFE	75	47-10070	
112961	18	Nickel	PTFE	75	47-10070	
112962	19	Nickel	PTFE	75	47-10150	
112990	08A	Nickel	PTFE	75	47-10100	



112961

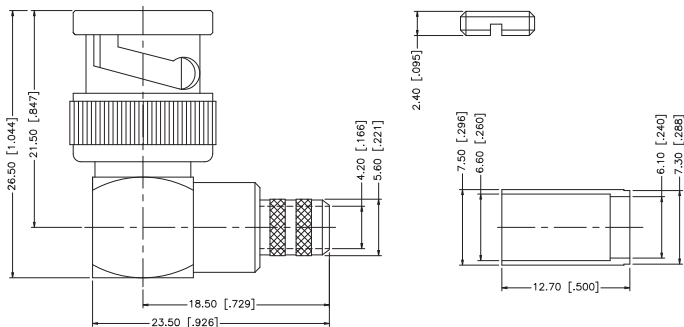



# BNC CONNECTORS

## CABLE MOUNT, STRAIGHT JACK

P.N.	Cable Group	Finish	Insulation	Impedance	Crimp Tool	Notes
112989	16	Nickel	PTFE	75	47-10120	
112974	19	Nickel	PTFE	75	47-10120	
112973	18	Nickel	PTFE	75	47-10110	
112966	08B	Nickel	PTFE	75	47-10110	
112965	08A	Nickel	PTFE	75	47-10110	

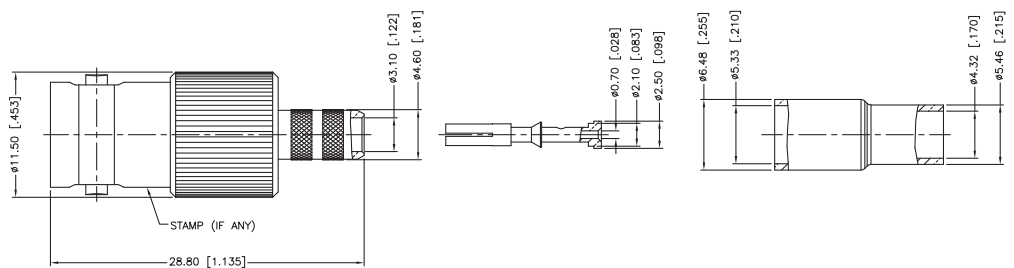

## CABLE MOUNT, STRAIGHT BULKHEAD JACK

P.N.	Cable Group	Finish	Insulation	Impedance	Crimp Tool	Notes
112970	18	Nickel	PTFE	75	47-10110	
112969	19	Nickel	PTFE	75	47-10120	
112662-10	08A	Nickel	PTFE	75	47-10110	

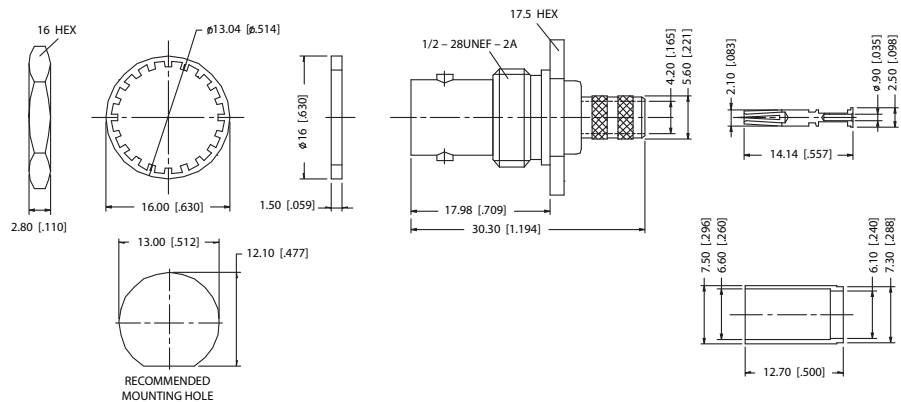

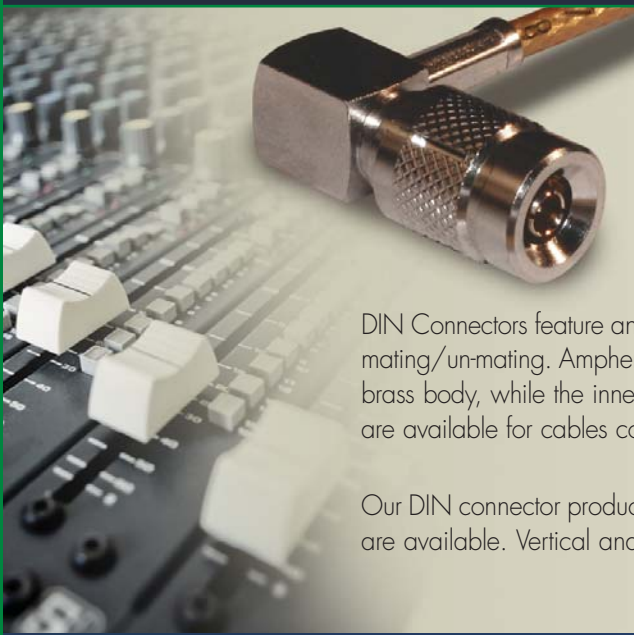

Our comprehensive line of 75 Ohm 1.0 /2.3 DIN Coaxial Connectors are ideal for use in high-performance 3Gb/s HD/SDI video applications. DIN Connectors are smaller in size than the BNC connectors commonly used in the broadcast industry, allowing up to four times as many signals in the same area.

DIN Connectors feature an innovative push-pull coupling mechanism that allows for quick and easy mating/un-mating. Amphenol Connex's DIN connectors feature a precision-machined, nickel-plated brass body, while the inner/outer contacts feature gold-over-nickel plating. Crimp plugs and jacks are available for cables commonly used in the broadcast and video industry.

Our DIN connector product line includes cable mount plugs and jacks. Bulkhead mounting options are available. Vertical and right angle PCB mount receptacles are also available.

### Features & Benefits

- Innovative push-pull coupling mechanism allows quick and easy mating and un-mating
- 75 Ohm versions operate to 3+ GHz and meet the SMPTE return-loss requirements
- Complies with DIN 41626, DIN 47297, INFC 93569, INFC 93571 and CECC 22230 requirements
- Ideal for high-density applications where space is limited

### Common Applications

- High-definition video routers (3 Gb/s applications)
- Audio/video switching devices
- Digital video recorders and playback systems
- Mobile video units

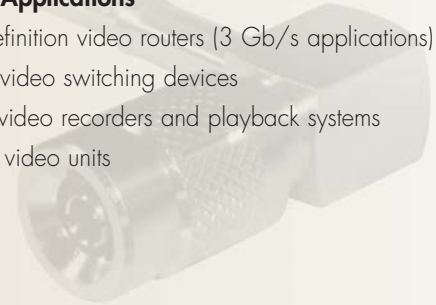

### ELECTRICAL SPECIFICATIONS

Impedance	75 ohms
Frequency Range	0 to 4 GHz
Voltage Rating (at sea level)	≥ 250 Vrms (depending on cable)
Contact resistance	Center contact, 6 Milliohm Max Outer contact, 3 Milliohm Max
Insulation resistance	10,000 Megohms Min

### MATERIAL SPECIFICATIONS

Component	Material	Finish
Contact – Male	Brass	Gold plated
Center – Female (center and outer)	Beryllium Copper	Gold plated
Other Metal Parts	Brass	Nickel
Dielectric	PTFE	Natural
Crimp Ferrule	Copper Alloy	Nickel

# 1.0/2.3 DIN COAXIAL CONNECTORS

C A B L E G R O U P L E G E N D		
01	58/ 58A/ 58C/ 141/ 303/ LMR195™/ B7806A	06A 179/ U DOUBLE BRAIDED
01A	55/ 142/ 223/ 400	07 8/ 8A/ 213/ 393
01B	LMR200™/ B7807A	07A 214/ 225
01C	LMR300™/ B7809A	07B 8X/ LMR240™/ B7808A
02	58 PLENUM/ THINNET/ 122U/ B88240/ B89907	07C B9913/ LMR400™/ B7810A/ B8214
03	59/ 62/ 140/ 210	07D B89913
03A	59/ U-20AWG/ B1505	07E 11
04	59/ U PLENUM/ B9108/ B9104	07F 11/ U-14AWG/ B8213/ B9292/ B7731/ B1859A
04A	59/ U PLENUM-20AWG	08 6/ U B3093A QUADSHIELD
05	174/ 188A/ 316/ B7805A/ LMR100™	08A B1694A/ B9248/ B3093A QUAD SHIELD
05A	316/ U DOUBLE BRAIDED	08B 6 PLENUM/ B1695A/ B89248
06	179/ 187/ B9221	09 B8227/ 89207
		10 .141 SEMI-RIGID/ 402/U
		11 .085 SEMI-RIGID/ 405/U
		12 .250 SEMI-RIGID
		13 .047 SEMI-RIGID/ B1674A
		14 178/ 196
		15 B8281/ B9231/ B9141
		15A B88281
		16 180/ 195/ 122/ B8218/ B1865A/ B1855
		17 LMR600™
		18 AT&T734A/ B1505A/ B9145
		19 AT&T735A/ B735A1
		20 AMC 1.13mm cable
		21 AMC 1.32mm cable
		22 AMC 1.37mm cable

## PCB MOUNT, VERTICAL RECEPTACLE

P.N.	Cable Group	Finish	Insulation	Impedance	Crimp Tool	Notes
282127-75	N/A	Gold	PTFE	75	N/A	4-Legs
282127-75-10	N/A	Gold	PTFE	75	N/A	3-Legs

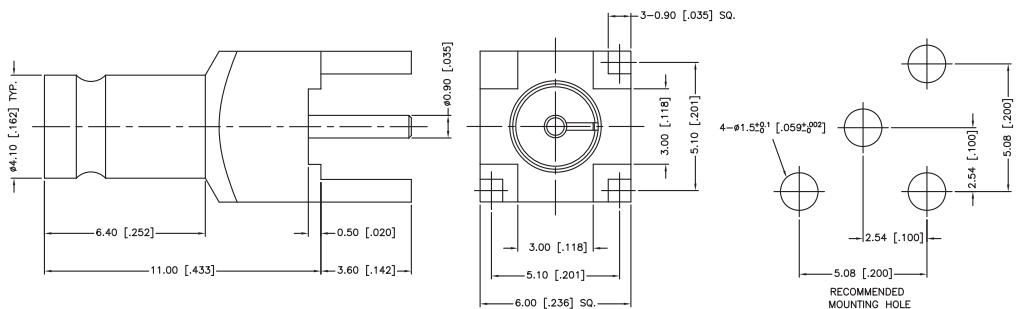
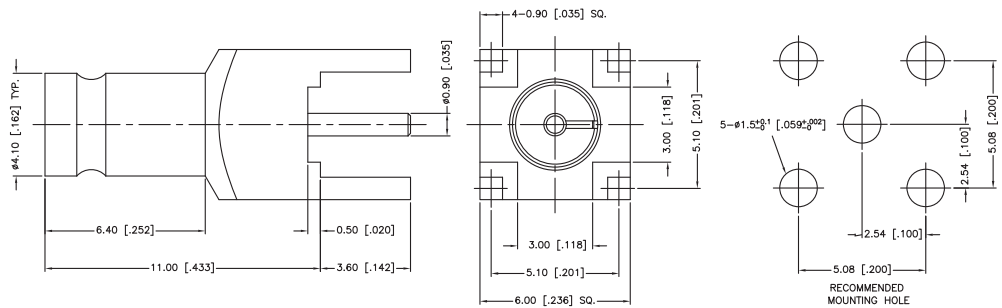

# 1.0/2.3 DIN COAXIAL CONNECTORS

## PCB MOUNT, VERTICAL BULKHEAD RECEPTACLE

P.N.	Cable Group	Finish	Insulation	Impedance	Crimp Tool	Notes
282121-75	N/A	GOLD	PTFE	75	N/A	



282121-75

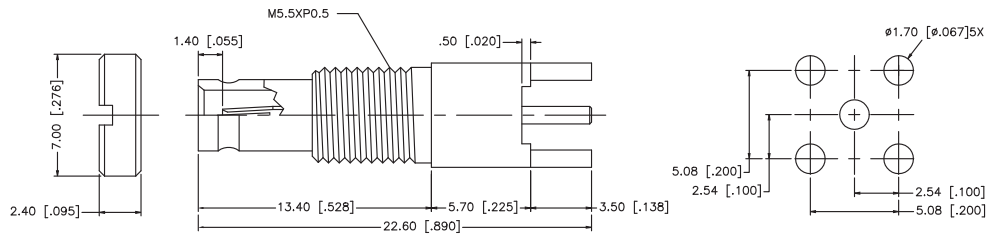

## PCB MOUNT, VERTICAL BULKHEAD RECEPTACLE, SMT

P.N.	Cable Group	Finish	Insulation	Impedance	Crimp Tool	Notes
282134-75	N/A	Gold	PTFE	75	N/A	



282134-75

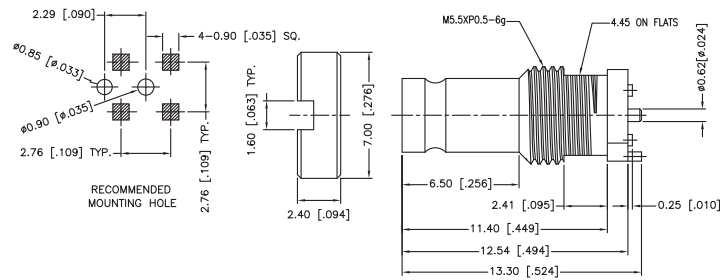

## PCB MOUNT, RIGHT ANGLE BULKHEAD RECEPTACLE

P.N.	Cable Group	Finish	Insulation	Impedance	Crimp Tool	Notes
282139-75	N/A	Gold/Tin	PTFE	75	N/A	



282139-75

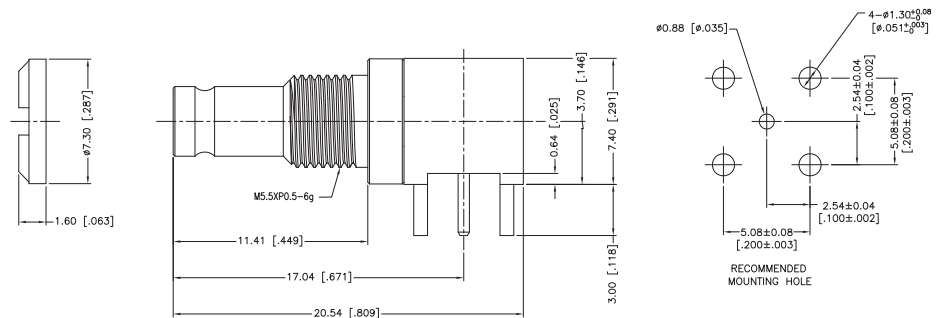

# 1.0/2.3 DIN COAXIAL CONNECTORS

## PCB MOUNT, END LAUNCH RECEPTACLE

P.N.	Cable Group	Finish	Insulation	Impedance	Crimp Tool	Notes
282132-75	N/A	GOLD	PTFE	75	N/A	for 0.062 Inch Thick PCB

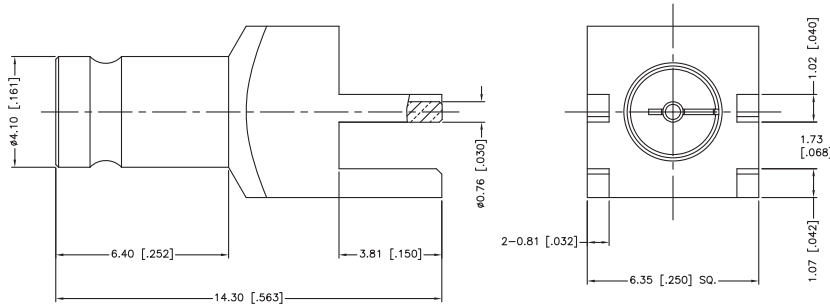

## PCB MOUNT, END LAUNCH BULKHEAD RECEPTACLE

P.N.	Cable Group	Finish	Insulation	Impedance	Crimp Tool	Notes
282133-75	N/A	GOLD	PTFE	75	N/A	for 0.062 Inch Thick PCB

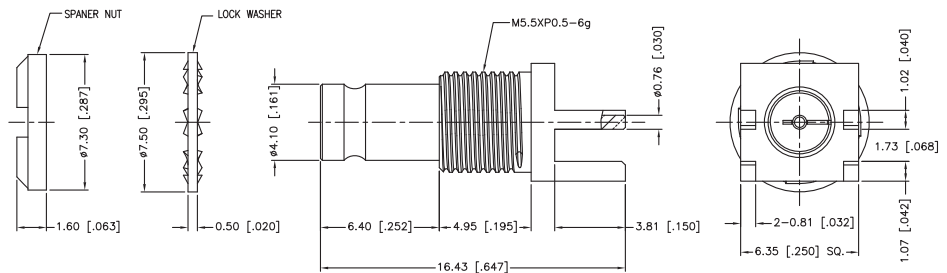

# 1.0/2.3 DIN COAXIAL CONNECTORS

## CABLE MOUNT, STRAIGHT PLUGS

P.N.	Cable Group	Finish	Insulation	Impedance	Crimp Tool	Notes
282103-75	06	Nickel	PTFE	75	47-10120	
282118-75	19	Nickel	PTFE	75	47-10120	
282135-75	18	Nickel	PTFE	75	47-10110	
282136-75	08B	Nickel	PTFE	75	47-10110	
282137-75	08A	Nickel	PTFE	75	47-10240	
282138-75	16	Nickel	PTFE	75	47-10120	



282138-75

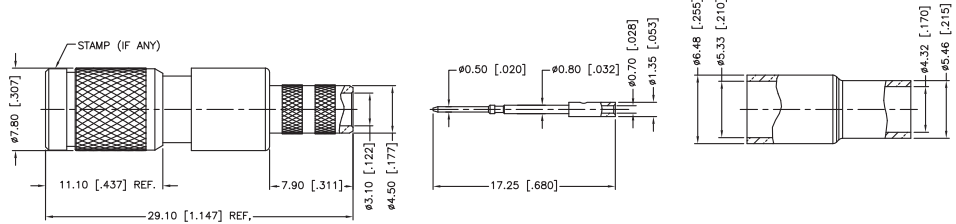

## CABLE MOUNT, RIGHT ANGLE PLUGS

P.N.	Cable Group	Finish	Insulation	Impedance	Crimp Tool	Notes
282119-75	19	Nickel	PTFE	75	47-10150	



282119-75

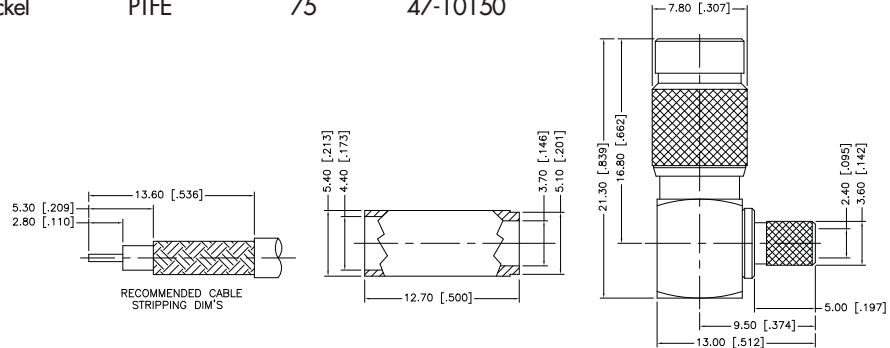

## CABLE MOUNT, STRAIGHT BULKHEAD JACKS

P.N.	Cable Group	Finish	Insulation	Impedance	Crimp Tool	Notes
282102-75	06	Gold/Nickel	PTFE	75	47-10150	



282102-75

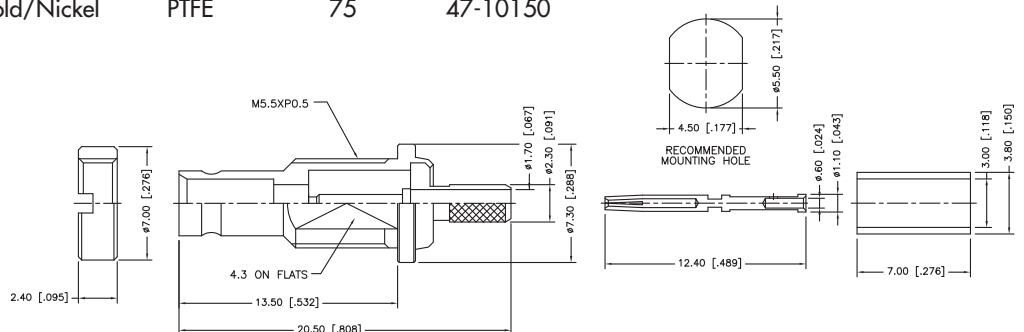



Amphenol Connex offers a wide range of 75 ohm BNC and 1.0/2.3 DIN coaxial adapters. In-series adapters, often used to change gender, are available. Additionally, between series adapters in a variety of configurations are available.

The adapters in this section are designed for high performance video applications and offer low return loss for fast 3 Gb/s data transfer rates. Various mounting features and custom solutions are also available.

P.N.	Cable Group	Finish	Insulation	Impedance	Crimp Tool	Notes
242229-75	N/A	Gold/Nickel	PTFE	75	N/A	1.0/2.3 DIN Jack to BNC Jack Adapter, 75 Ohm

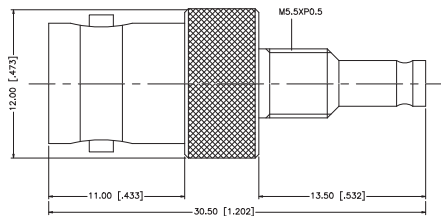

P.N.	Cable Group	Finish	Insulation	Impedance	Crimp Tool	Notes
242231-75	N/A	Gold/Nickel	PTFE	75	N/A	1.0/2.3 DIN Jack to BNC Plug Adapter, 75 Ohm

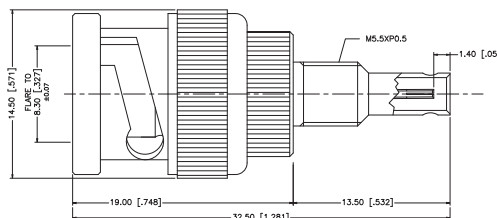

# ADAPTERS

P.N.	Cable Group	Finish	Insulation	Impedance	Crimp Tool	Notes
242238-75	N/A	Nickel	PTFE	75	N/A	1.0/2.3 DIN Plug to BNC Jack Adapter, 75 Ohm



242238-75

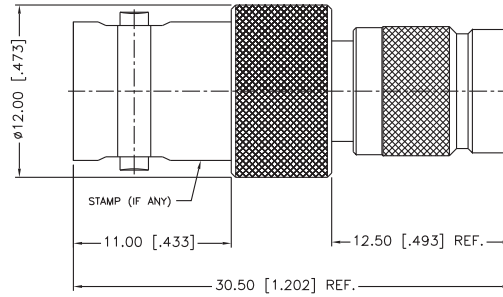

P.N.	Cable Group	Finish	Insulation	Impedance	Crimp Tool	Notes
112769	N/A	Nickel	PTFE	75	N/A	BNC Jack to BNC Bulkhead Push-On Plug, 75 Ohm



112769

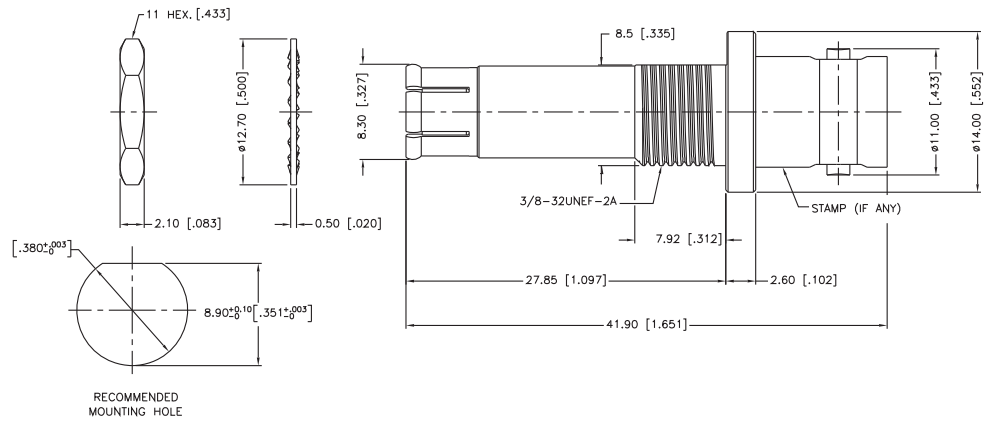

P.N.	Cable Group	Finish	Insulation	Impedance	Crimp Tool	Notes
112446	N/A	Nickel	Delrin	75	N/A	BNC Jack to BNC Jack Barrel Adapter, 75 ohm



112446

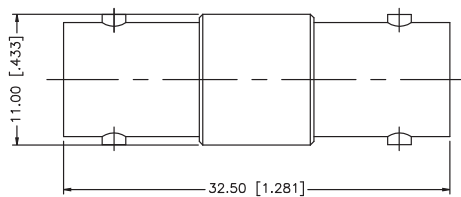



# ADAPTERS

P.N.	Cable Group	Finish	Insulation	Impedance	Crimp Tool	Notes
112448	N/A	Nickel	Delrin	75	N/A	BNC Plug to BNC Plug Barrel Adapter, 75 ohm

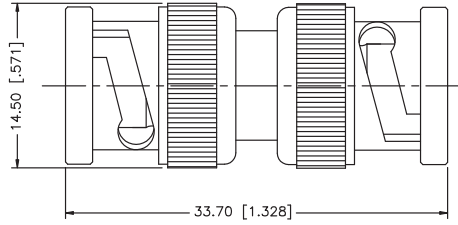

P.N.	Cable Group	Finish	Insulation	Impedance	Crimp Tool	Notes
112668	N/A	Nickel	PTFE	75	N/A	BNC Plug to BNC Jack Barrel Adapter, 75 ohm

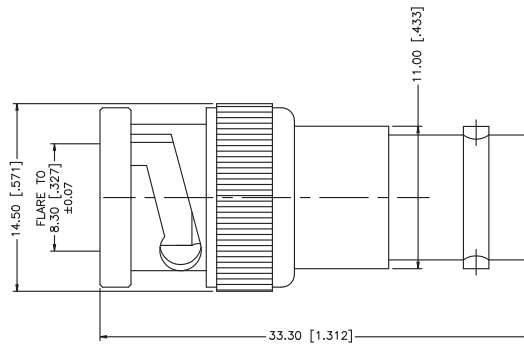

P.N.	Cable Group	Finish	Insulation	Impedance	Crimp Tool	Notes
112434	N/A	Nickel	Delrin	75	N/A	BNC Jack to BNC Jack Bulkhead Adapter for 8.0 mm Max Panel Thickness, 75 ohm

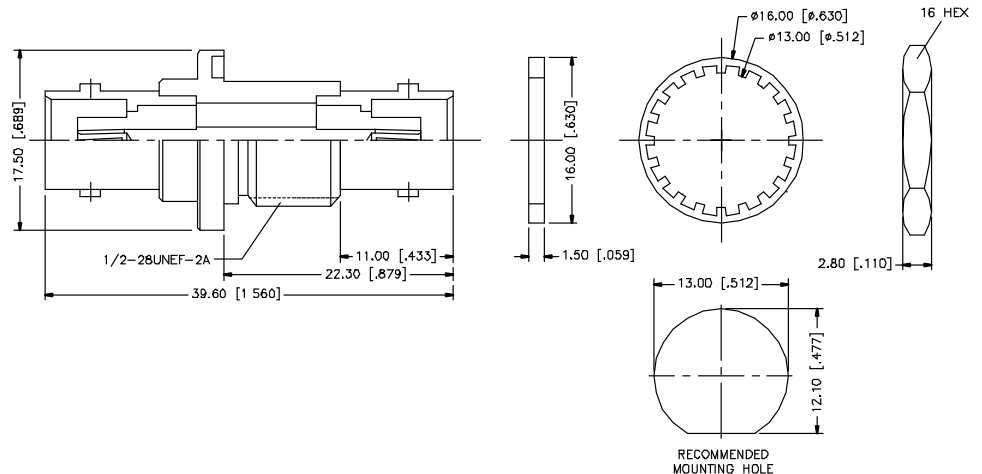

# ADAPTERS

P.N.	Cable Group	Finish	Insulation	Impedance	Crimp Tool	Notes
112438	N/A	Nickel	Delrin	75	N/A	BNC Jack to BNC Jack Bulkhead Adapter for 5.5 mm Max Panel Thickness, 75 ohm

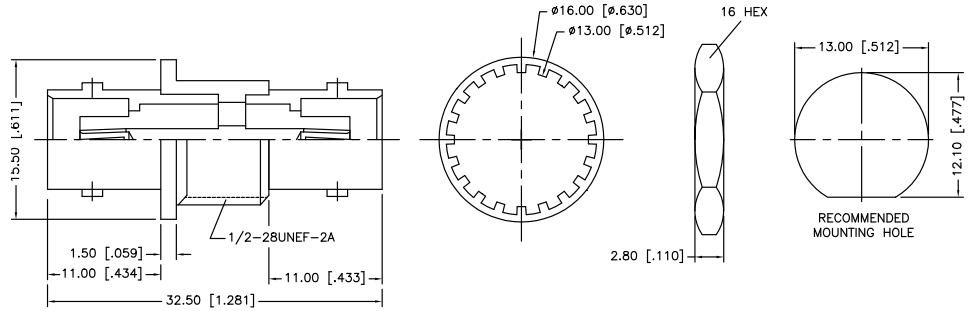

P.N.	Cable Group	Finish	Insulation	Impedance	Crimp Tool	Notes
112532	N/A	Nickel	PTFE	75	N/A	BNC Bulkhead Jack to BNC Push-On Plug Adapter, 75 ohm

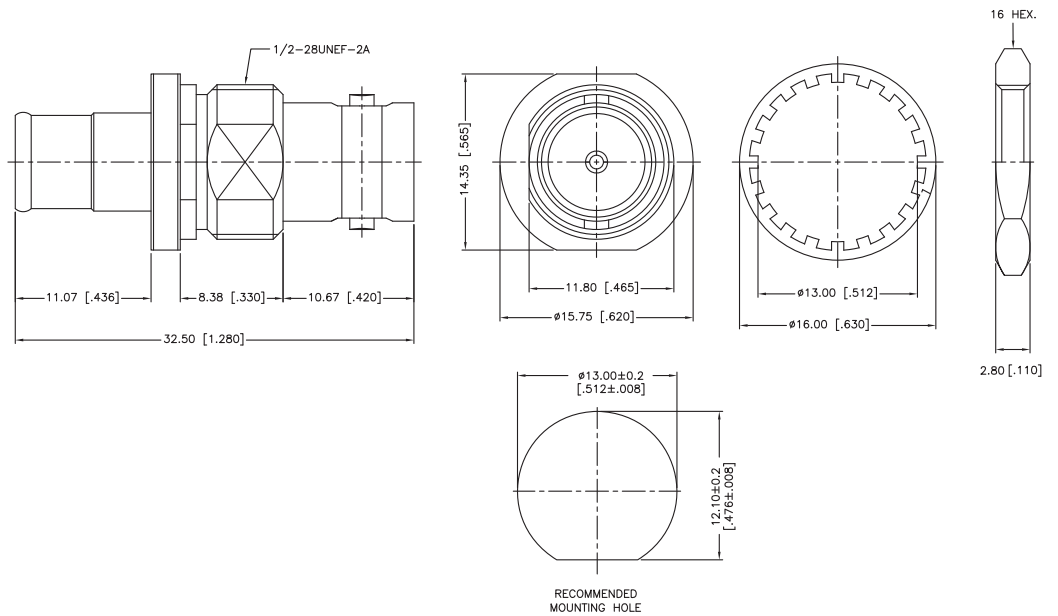

## TERMINATORS

P.N.	Cable Group	Finish	Insulation	Impedance	Crimp Tool	Notes
202119	N/A	Nickel	PTFE	75	N/A	



202119

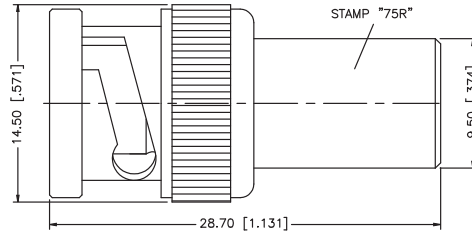

## UNIVERSAL HAND CRIMP TOOLS

Amphenol Connex 47-XXXXX Series Crimp Tools utilize industry standard crimp die set dimensions. Tool handle can be purchased separately or with die set installed. Die sets listed below will terminate all popular coaxial cables. Full ratchet crimp action assures a complete crimp before tool releases. Call Amphenol Connex for custom die configurations.



### Standard Coax Tools Available from Amphenol Connex

#### 47-10000 UNIVERSAL TOOL FRAME WITHOUT DIE SET

CRIMP TOOL WITH DIE SET	DIE SET ONLY	DIE CAVITIES	CABLE GROUPS
<b>47-10070</b>	<b>47-20000</b>	.255/.213/.068	RG 55/ 58/ 59/ 62/ 141/ 142/ 233/ 303/ 400
<b>47-10100</b>	<b>47-20026</b>	.350/.320/.255	RG59/6
<b>47-10150</b>	<b>47-20004</b>	.178/.128/.068	RG 174/ 188/ 316/ 179/ 187/ 180/ 195/ 178/ 196
<b>47-10110</b>	<b>47-20001</b>	.324/.255/.068/.042	RG 6/ 59/ B8281
<b>47-10120</b>	<b>47-20002</b>	.213/.178/.068/.042	RG 58/ 174/ 188/ 316/ 179/ 187/ 142/ 141/ 223/ 400/ 55
<b>47-10240</b>	<b>47-20030</b>	.278/.255/.068/.042	B1505A/ B1694A (FOR KINGS 2065-10-9)
<b>47-10270</b>	<b>47-20250</b>	.178/.128/.068/.042	BNC/ TNC/ .068 AND .042 CRIMP CENTER CONTACT



**Amphenol Connex**

5069 Maureen Lane, Unit B  
Moorpark, CA 93021 USA

**805.378.6464**

**800.942.6639**

**[www.amphenolconnex.com](http://www.amphenolconnex.com)**



Компания «ЭлектроПласт» предлагает заключение долгосрочных отношений при поставках импортных электронных компонентов на взаимовыгодных условиях!

Наши преимущества:

- Оперативные поставки широкого спектра электронных компонентов отечественного и импортного производства напрямую от производителей и с крупнейших мировых складов;
- Поставка более 17-ти миллионов наименований электронных компонентов;
- Поставка сложных, дефицитных, либо снятых с производства позиций;
- Оперативные сроки поставки под заказ (от 5 рабочих дней);
- Экспресс доставка в любую точку России;
- Техническая поддержка проекта, помощь в подборе аналогов, поставка прототипов;
- Система менеджмента качества сертифицирована по Международному стандарту ISO 9001;
- Лицензия ФСБ на осуществление работ с использованием сведений, составляющих государственную тайну;
- Поставка специализированных компонентов (Xilinx, Altera, Analog Devices, Intersil, Interpoint, Microsemi, Aeroflex, Peregrine, Syfer, Eurofarad, Texas Instrument, Miteq, Cobham, E2V, MA-COM, Hittite, Mini-Circuits, General Dynamics и др.);

Помимо этого, одним из направлений компании «ЭлектроПласт» является направление «Источники питания». Мы предлагаем Вам помощь Конструкторского отдела:

- Подбор оптимального решения, техническое обоснование при выборе компонента;
- Подбор аналогов;
- Консультации по применению компонента;
- Поставка образцов и прототипов;
- Техническая поддержка проекта;
- Защита от снятия компонента с производства.



#### Как с нами связаться

**Телефон:** 8 (812) 309 58 32 (многоканальный)

**Факс:** 8 (812) 320-02-42

**Электронная почта:** [org@eplast1.ru](mailto:org@eplast1.ru)

**Адрес:** 198099, г. Санкт-Петербург, ул. Калинина, дом 2, корпус 4, литера А.