

**3M™ LATCH/EJECT HEADER, 1552 SERIES**  
 2MM X 2MM STRAIGHT & RIGHT ANGLE, THROUGH-HOLE, STRAIGHT & SURFACE MOUNT



5 1552XX-X20X  
 LATCH MATING FOR  
 MOLDED-ON SOCKET  
 WITH LATCHING EAR



5 1552XX-X30X  
 LATCH MATING FOR  
 PRESS-ON SOCKET



5 1552XX-X40X  
 LATCH MATING FOR  
 2MM SCI CARRIER

**3 ELECTRICAL PERFORMANCE:**

CURRENT RATING: 4.75A, 1 LINE POWERED  
 2.00A, 6 ADJACENT LINES POWERED  
 1.25A, ALL LINES POWERED

RATING CONDITIONS: EIA-364-070 METHOD 2, 30°C MAXIMUM TEMPERATURE  
 RISE, 20% DERATED. REFERENCE APPROPRIATE 3M PRODUCT  
 SPECIFICATION FOR DETAILED CURRENT DERATING CURVES.

INSULATION RESISTANCE: > 1X10<sup>9</sup> OHMS AT 500 V<sub>DC</sub>  
 WITHSTANDING VOLTAGE (1552XX): 1000 V<sub>RMS</sub> AT SEA LEVEL  
 WITHSTANDING VOLTAGE (G1552XX): 750 V<sub>RMS</sub> AT SEA LEVEL

**3 ENVIRONMENTAL:**

TEMPERATURE RATING: -55°C TO +105°C  
 PROCESS RATING: MAXIMUM 260°C (PER J-STD-020)  
 MOISTURE SENSITIVITY LEVEL: 1 (PER J-STD-020)

- \* 14 PIN COUNTS RANGING FROM 06 TO 50 POSITIONS.
- \* LATCH/EJECT MECHANISM SECURELY LATCHES TO SOCKET.
- \* ROLL PINS RETAIN LATCHES TO BODY IN SHIPPING AND HIGH VIBRATION ENVIRONMENTS.
- \* EJECTOR HELPS MAKE UNMATING OF CABLE ASSEMBLIES EASIER.
- \* HIGH TEMPERATURE INSULATORS SUITABLE FOR LEAD FREE PROCESSING.
- \* ROBUST SYSTEM SOLUTION WHEN USED WITH 3M IDC WIREMOUNT SOCKETS OR 3M MOLDED CABLE ASSEMBLIES.
- \* SMT LATCH/EJECT HEADERS ARE AVAILABLE IN TAPE AND REEL WITH VACUUM CAP FOR AUTOMATIC PLACEMENT.

- NOTES
1. MATERIAL:  
 PLASTIC:  
 GLASS FILLED POLYESTER (LCP)  
 UL94V-0, BLACK  
 CONTACT: COPPER ALLOY.
  2. PLATING:  
 50μ NICKEL UNDERPLATING  
 WIPE AREA: SEE ORDERING INFO.  
 SOLDER TAIL: 200μ MATTE TIN.
  3. IN THE EVENT OF CONFLICT BETWEEN THIS DATA AND THAT CONTAINED IN THE PRODUCT SPECIFICATION, THE PRODUCT SPECIFICATION TAKES PRECEDENT.
  4. REGULATORY INFORMATION:  
 VISIT 3M.com/regs OR CONTACT YOUR 3M REPRESENTATIVE TO FIND THE RoHS COMPLIANCE STATUS OF THE 3M PART YOU ARE INTERESTED IN.
  5. SEE TABLE 1 FOR LATCH AVAILABILITY.
  6. MATING COMPATIBILITY SERIES:  
 1522, 870, 2M AND 2MM SCI CARRIER (93XX).
  7. SURFACE MOUNT VERSION:  
 ORDER CODE APPLIES TO THE TAPE AND REEL WIDTH.

TABLE 1

CONTACT QTY.	DIM. "A"	DIM. "B"	DIM. "D"	LATCH OPTION	TAPE WIDTH	ORDER CODE	CONTACT QTY.
06	.673 [17.09]	.157 [4.00]	.333 [8.45]	2, 4	44 MM	WD	06
08	.752 [19.10]	.236 [6.00]	.411 [10.44]	2, 4	44 MM	WD	08
10	.831 [21.10]	.315 [8.00]	.490 [12.45]	2, 3, 4	44 MM	WD	10
12	.910 [23.10]	.394 [10.00]	.569 [14.45]	3, 4	44 MM	WD	12
16	1.067 [27.10]	.551 [14.00]	.726 [18.44]	2, 4	56 MM	WE	16
20	1.224 [31.09]	.709 [18.00]	.884 [22.45]	2, 3, 4	56 MM	WE	20
22	1.303 [33.10]	.787 [20.00]	.963 [24.46]	2, 4	56 MM	WE	22
24	1.382 [35.10]	.866 [22.00]	1.041 [26.44]	2, 4	56 MM	WE	24
26	1.461 [37.10]	.945 [24.00]	1.120 [28.45]	2, 3, 4	72 MM	WF	26
30	1.618 [41.10]	1.102 [28.00]	1.278 [32.46]	2, 4	72 MM	WF	30
34	1.774 [45.09]	1.260 [32.00]	1.435 [36.46]	2, 4	72 MM	WF	34
40	2.012 [51.10]	1.496 [38.00]	1.671 [42.44]	2, 3, 4	72 MM	WF	40
44	2.169 [55.09]	1.654 [42.00]	1.829 [46.46]	2, 3, 4	88 MM	WG	44
50	2.405 [61.09]	1.980 [48.00]	2.065 [54.45]	2, 3, 4	88 MM	WG	50

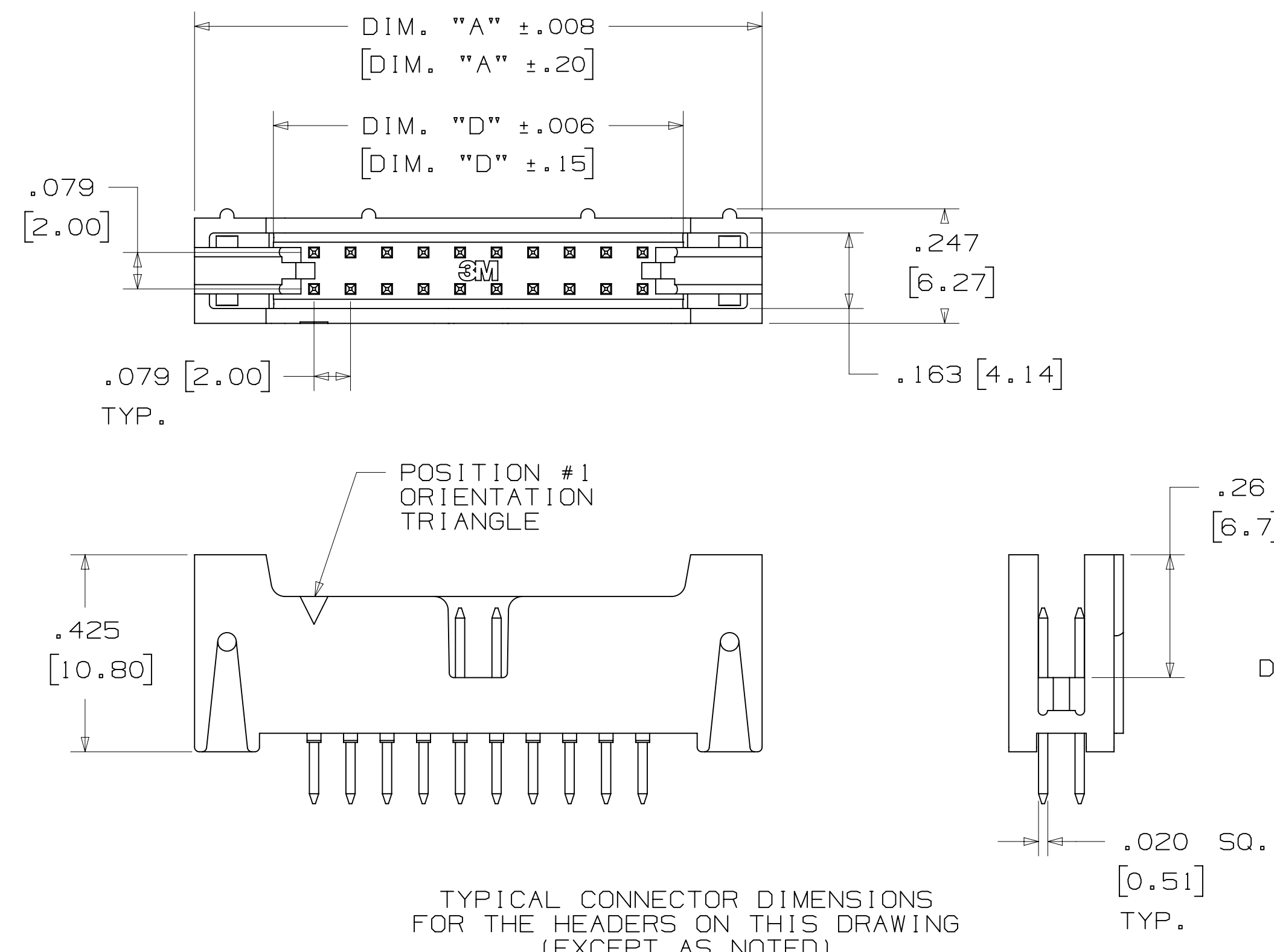

TYPICAL CONNECTOR DIMENSIONS FOR THE HEADERS ON THIS DRAWING (EXCEPT AS NOTED)

DIMENSIONS: MM [ INCHES ]

DESIGN REFERENCE	NEXT ASSEMBLY	REV	ECO	ISSUE DATE AND DESCRIPTION	DRFT	CHKD
DIVISION	DIVISION CODE	DATE	DATE	DATE	DATE	DATE
	EMSD	JAN 21, 2015	JAN 21, 2015	JAN 21, 2015		
DO NOT SCALE DRAWING	SCALE 4/1	TOLERANCES EXCEPT AS NOTED		INCHES .00 ± .01 .000 ± .008 .0000 ±		
THIRD ANGLE PROJECTION	INTERPRET PER ASME Y14.5 - 2009	MILLIMETERS		0 ± .3 .00 ± .20 .000 ±		
MAX SURFACE ROUGHNESS	1.6 SURFACES	CAGE NUMBER	SIZE	DRAWING NO.	REV.	
✓ MARKED ONLY	ANGLER	D		78-5100-2199-7	L	
		MODEL	1552	DET	ISTS	YES X NO
						SHT 1 OF 4

3M ELECTRONICS MATERIALS SOLUTIONS DIVISION  
 INTERCONNECT SOLUTIONS  
<http://www.3mconnectors.com>

3M IS A TRADEMARK OF 3M COMPANY.  
 FOR TECHNICAL, SALES OR ORDERING  
 INFORMATION CALL 800-225-5373

78-5100-2199-7  
 DRAWING NUMBER  
 1552  
 TIME: 5/17/2017 10:45:00 AM  
 OFFSET

3M™ LATCH/EJECT HEADER, 1552 SERIES  
2MM X 2MM STRAIGHT & RIGHT ANGLE, THROUGH-HOLE, STRAIGHT & SURFACE MOUNT

STRAIGHT VERSION



ORDERING INFORMATION  
1552XX-6X0X-XX

CONTACT QUANTITY:  PLATING OPTIONS:  
 RB = 30µIN [.76µm] GOLD  
 RA = 10µIN [.25µm] GOLD  
 (RIA E1 & C1 APPLY) FOR BOTH PLATINGS

LATCHING OPTIONS:  
 2 = LATCH, MOLDED-ON SOCKET WITH LATCHING EARS, SERIES: 870, 2MM  
 3 = LATCH, PRESS-ON SOCKET, SERIES: 1522  
 4 = LATCH, 2MM SCI CARRIER ONLY, SERIES: 93XX

SOLDER TAIL LENGTH:  
 DIMENSION "E"  
 2 = .112 [2.84]  
 3 = .155 [3.94]

STRAIGHT VERSION WITH INTERSTITIAL GROUNDS



ORDERING INFORMATION  
G1552XX-6X0X-XX

CONTACT QUANTITY:  PLATING OPTIONS:  
 RB = 30µIN [.76µm] GOLD  
 RA = 10µIN [.25µm] GOLD  
 (RIA E1 & C1 APPLY) FOR BOTH PLATINGS

LATCHING OPTIONS:  
 4 = LATCH, 2MM SCI CARRIER ONLY, SERIES 93XX

SOLDER TAIL LENGTH:  
 DIMENSION "E"  
 2 = .112 [2.84]

DESIGN REFERENCE	NEXT ASSEMBLY	REV	ECO	ISSUE DATE AND DESCRIPTION	DRFT	CHKD
DATE	DATE	DATE	DATE	DATE	DATE	DATE
CHKD	DATE	APPV	DATE	DATE	DATE	DATE
DIVISION	DIVISION CODE	© 3M COPYR [GHT] 2017 This document and the information it contains are 3M property and may not be reproduced or further distributed without 3M permission, or used or disclosed other than for 3M authorized purposes. All rights reserved.				
DO NOT SCALE DRAWING	SCALE 4/1	TOLERANCES EXCEPT AS NOTED	<b>3M</b> Center St. Paul, MN 55144			
THIRD ANGLE PROJECTION	INCHES .00 ±.01 .000 ±.008 .0000 ±	MILLIMETERS 0 ± .0 ±.3 .00 ±.20	TITLE LATCH/EJECT HEADER, 2MM, STRAIGHT, RIGHT ANGLE & SMT			
MAX SURFACE ROUGHNESS	INCHES SURFACES .000 ±	MARKED ONLY	CAGE NUMBER	SIZE	DRAWING NO.	REV.
			D	78-5100-2199-7	L	
			MODEL	1552	DET	ISTS <input type="checkbox"/> YES <input checked="" type="checkbox"/> NO SHT 2 OF 4

78-5100-2199-7 DRAWING NUMBER  
 Revision  
 Standard Time5/17/2017UTC Offset

3M™ LATCH/EJECT HEADER, 1552 SERIES  
2MM X 2MM STRAIGHT & RIGHT ANGLE, THROUGH-HOLE, STRAIGHT & SURFACE MOUNT

RIGHT ANGLE VERSION



RECOMMENDED PC BOARD PATTERN  
(VIEWED FROM CONNECTOR SIDE)

ORDERING INFORMATION

1552XX-5X0X-XX

CONTACT QUANTITY: \_\_\_\_\_

LATCHING OPTIONS:  
2 = LATCH, MOLDED-ON SOCKET WITH LATCHING EARS, SERIES: 870, 2MM  
3 = LATCH, PRESS-ON SOCKET, SERIES: 1522  
4 = LATCH, 2MM SCI CARRIER ONLY, SERIES 93XX

PLATING OPTIONS:  
RB = 30µIN [.76µm] GOLD  
RA = 10µIN [.25µm] GOLD  
(RIA E1 & C1 APPLY) FOR BOTH PLATINGS

SOLDER TAIL LENGTH:  
DIMENSION "E"  
2 = .112 [2.84]  
3 = .155 [3.94]

SURFACE MOUNT VERSION

NOTES:

- 1) TAPE & REEL PARTS ALWAYS SUPPLIED WITH VACUUM PICK-UP CAP.
- 2) TAPE & REEL NOT AVAILABLE WITH SCI LATCH OPTION.
- 3) TRAY PARTS SUPPLIED WITHOUT VACUUM PICK-UP CAP.



RECOMMENDED PC BOARD PATTERN  
(VIEWED FROM CONNECTOR SIDE)

ORDERING INFORMATION

1552XX-2X00-XX-XX

CONTACT QUANTITY: \_\_\_\_\_

LATCHING OPTIONS:  
2 = LATCH, MOLDED-ON SOCKET WITH LATCHING EARS, SERIES: 870, 2MM  
3 = LATCH, PRESS-ON SOCKET, SERIES: 1522  
4 = LATCH, 2MM SCI CARRIER ONLY, SERIES 93XX

PACKAGING:  
BLANK = TRAYS  
WX = TAPE & REEL  
(SEE TABLE 1 ORDER CODE)

PLATING OPTIONS:  
RB = 30µIN [.76µm] GOLD  
RA = 10µIN [.25µm] GOLD  
(RIA E1 & C1 APPLY) FOR BOTH PLATINGS

DESIGN REFERENCE	NEXT ASSEMBLY	REV	ECO	ISSUE DATE AND DESCRIPTION	DRFT	CHKD
DATE	DATE	DATE	DATE	DATE	DATE	DATE
CHKD	DATE	APPV	DATE			
		R. SCHERER	JAN 21, 2015			
DIVISION	DIVISION CODE	This document and the information it contains are 3M property and may not be reproduced or further distributed without 3M permission, or used or disclosed other than for 3M authorized purposes. All rights reserved.				
DO NOT SCALE DRAWING	SCALE 4/1	TOLERANCES EXCEPT AS NOTED	INCHES .00 ±.01 .000 ±.008 .0000 ±			
THIRD ANGLE PROJECTION	INTERPRET PER ASME Y14.5 - 2009	MILLIMETERS	0 ±.3 .00 ±.20 .000 ±			
MAX SURFACE ROUGHNESS	MARKED ONLY	ANGLE	CAGE NUMBER	SIZE	DRAWING NO.	REV.
			D	78-5100-2199-7	L	
			MODEL	1552	DET	ISTS
					YES	NO
					SHT	3 OF 4

L 58601 AUG 11, 2016  
8-11-16 ADD SHT 4  
REVISE TRADEMAKE NOTE  
JUN 01, 2016  
PRODUCTION RELEASE,  
APR 29, 2016

Imaged: L.6 Central Standard Time 5/17/2017 UTC OffSet





Компания «ЭлектроПласт» предлагает заключение долгосрочных отношений при поставках импортных электронных компонентов на взаимовыгодных условиях!

Наши преимущества:

- Оперативные поставки широкого спектра электронных компонентов отечественного и импортного производства напрямую от производителей и с крупнейших мировых складов;
- Поставка более 17-ти миллионов наименований электронных компонентов;
- Поставка сложных, дефицитных, либо снятых с производства позиций;
- Оперативные сроки поставки под заказ (от 5 рабочих дней);
- Экспресс доставка в любую точку России;
- Техническая поддержка проекта, помощь в подборе аналогов, поставка прототипов;
- Система менеджмента качества сертифицирована по Международному стандарту ISO 9001;
- Лицензия ФСБ на осуществление работ с использованием сведений, составляющих государственную тайну;
- Поставка специализированных компонентов (Xilinx, Altera, Analog Devices, Intersil, Interpoint, Microsemi, Aeroflex, Peregrine, Syfer, Eurofarad, Texas Instrument, Miteq, Cobham, E2V, MA-COM, Hittite, Mini-Circuits, General Dynamics и др.);

Помимо этого, одним из направлений компании «ЭлектроПласт» является направление «Источники питания». Мы предлагаем Вам помощь Конструкторского отдела:

- Подбор оптимального решения, техническое обоснование при выборе компонента;
- Подбор аналогов;
- Консультации по применению компонента;
- Поставка образцов и прототипов;
- Техническая поддержка проекта;
- Защита от снятия компонента с производства.



#### Как с нами связаться

**Телефон:** 8 (812) 309 58 32 (многоканальный)

**Факс:** 8 (812) 320-02-42

**Электронная почта:** [org@eplast1.ru](mailto:org@eplast1.ru)

**Адрес:** 198099, г. Санкт-Петербург, ул. Калинина, дом 2, корпус 4, литера А.