

**3M™ LATCH/EJECT HEADER, 1552 SERIES**  
 2MM X 2MM STRAIGHT & RIGHT ANGLE, THROUGH-HOLE, STRAIGHT & SURFACE MOUNT



5 1552XX-X20X  
 LATCH MATING FOR  
 MOLDED-ON SOCKET  
 WITH LATCHING EAR



5 1552XX-X30X  
 LATCH MATING FOR  
 PRESS-ON SOCKET



5 1552XX-X40X  
 LATCH MATING FOR  
 2MM SCI CARRIER

- \* 14 PIN COUNTS RANGING FROM 06 TO 50 POSITIONS.
- \* LATCH/EJECT MECHANISM SECURELY LATCHES TO SOCKET.
- \* ROLL PINS RETAIN LATCHES TO BODY IN SHIPPING AND HIGH VIBRATION ENVIRONMENTS.
- \* EJECTOR HELPS MAKE UNMATING OF CABLE ASSEMBLIES EASIER.
- \* HIGH TEMPERATURE INSULATORS SUITABLE FOR LEAD FREE PROCESSING.
- \* ROBUST SYSTEM SOLUTION WHEN USED WITH 3M IDC WIREMOUNT SOCKETS OR 3M MOLDED CABLE ASSEMBLIES.
- \* SMT LATCH/EJECT HEADERS ARE AVAILABLE IN TAPE AND REEL WITH VACUUM CAP FOR AUTOMATIC PLACEMENT.

3 ELECTRICAL PERFORMANCE:

CURRENT RATING: 4.75A, 1 LINE POWERED  
 2.00A, 6 ADJACENT LINES POWERED  
 1.25A, ALL LINES POWERED

RATING CONDITIONS: EIA-364-070 METHOD 2, 30°C MAXIMUM TEMPERATURE RISE, 20% DERATED. REFERENCE APPROPRIATE 3M PRODUCT SPECIFICATION FOR DETAILED CURRENT DERATING CURVES.

INSULATION RESISTANCE: > 1X10<sup>9</sup> OHMS AT 500 V<sub>DC</sub>  
 WITHSTANDING VOLTAGE (1552XX): 1000 V<sub>RMS</sub> AT SEA LEVEL  
 WITHSTANDING VOLTAGE (G1552XX): 750 V<sub>RMS</sub> AT SEA LEVEL

3 ENVIRONMENTAL:

TEMPERATURE RATING: -55°C TO +105°C  
 PROCESS RATING: MAXIMUM 260°C (PER J-STD-020)  
 MOISTURE SENSITIVITY LEVEL: 1 (PER J-STD-020)

CONTACT QTY.	DIM. "A"	DIM. "B"	DIM. "D"	LATCH OPTION	TAPE WIDTH	ORDER CODE	CONTACT QTY.
06	.673 [17.09]	.157 [4.00]	.333 [8.45]	2, 4	44 MM	WD	06
08	.752 [19.10]	.236 [6.00]	.411 [10.44]	2, 4	44 MM	WD	08
10	.831 [21.10]	.315 [8.00]	.490 [12.45]	2, 3, 4	44 MM	WD	10
12	.910 [23.10]	.394 [10.00]	.569 [14.45]	3, 4	44 MM	WD	12
16	1.067 [27.10]	.551 [14.00]	.726 [18.44]	2, 4	56 MM	WE	16
20	1.224 [31.09]	.709 [18.00]	.884 [22.45]	2, 3, 4	56 MM	WE	20
22	1.303 [33.10]	.787 [20.00]	.963 [24.46]	2, 4	56 MM	WE	22
24	1.382 [35.10]	.866 [22.00]	1.041 [26.44]	2, 4	56 MM	WE	24
26	1.461 [37.10]	.945 [24.00]	1.120 [28.45]	2, 3, 4	72 MM	WF	26
30	1.618 [41.10]	1.102 [28.00]	1.278 [32.46]	2, 4	72 MM	WF	30
34	1.774 [45.09]	1.260 [32.00]	1.435 [36.46]	2, 4	72 MM	WF	34
40	2.012 [51.10]	1.496 [38.00]	1.671 [42.44]	2, 3, 4	72 MM	WF	40
44	2.169 [55.09]	1.654 [42.00]	1.829 [46.46]	2, 3, 4	88 MM	WG	44
50	2.405 [61.09]	1.980 [48.00]	2.065 [54.45]	2, 3, 4	88 MM	WG	50

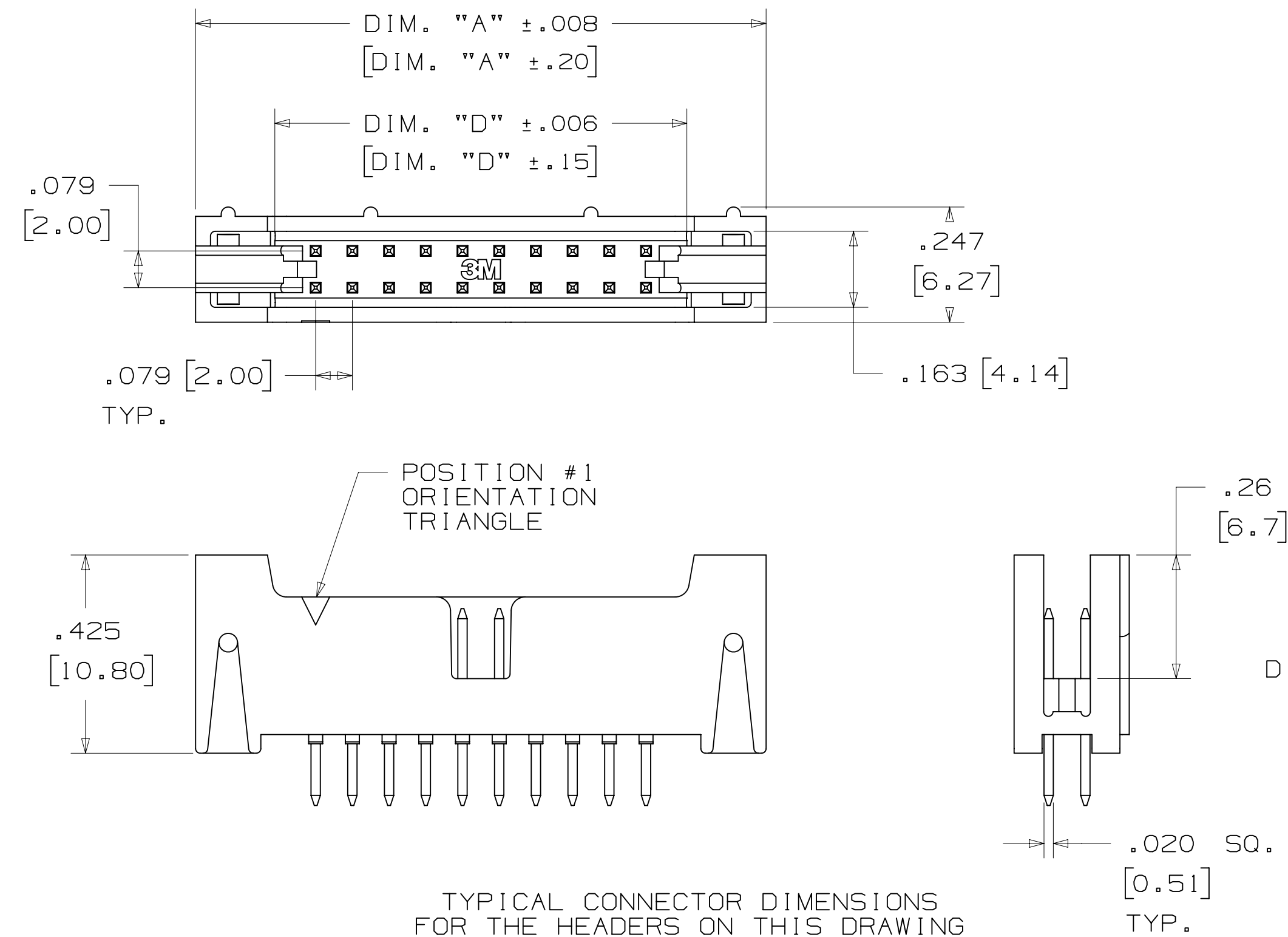

TYPICAL CONNECTOR DIMENSIONS FOR THE HEADERS ON THIS DRAWING (EXCEPT AS NOTED)

- NOTES
- MATERIAL:  
 PLASTIC:  
 GLASS FILLED POLYESTER (LCP)  
 UL94V-0, BLACK  
 CONTACT: COPPER ALLOY.
  - PLATING:  
 50μ NICKEL UNDERPLATING  
 WIPE AREA: SEE ORDERING INFO.  
 SOLDER TAIL: 200μ MATTE TIN.
  - IN THE EVENT OF CONFLICT BETWEEN THIS DATA AND THAT CONTAINED IN THE PRODUCT SPECIFICATION, THE PRODUCT SPECIFICATION TAKES PRECEDENT.
  - REGULATORY INFORMATION:  
 VISIT 3M.com/regs OR CONTACT YOUR 3M REPRESENTATIVE TO FIND THE RoHS COMPLIANCE STATUS OF THE 3M PART YOU ARE INTERESTED IN.
  - SEE TABLE 1 FOR LATCH AVAILABILITY.
  - MATING COMPATIBILITY SERIES:  
 1522, 870, 2M AND 2MM SCI CARRIER (93XX).
  - SURFACE MOUNT VERSION:  
 ORDER CODE APPLIES TO THE TAPE AND REEL WIDTH.

3M ELECTRONICS MATERIALS SOLUTIONS DIVISION  
 INTERCONNECT SOLUTIONS  
<http://www.3mconnectors.com>

3M IS A TRADEMARK OF 3M COMPANY.  
 FOR TECHNICAL, SALES OR ORDERING  
 INFORMATION CALL 800-225-5373

DESIGN REFERENCE	NEXT ASSEMBLY	REV	ECO	ISSUE DATE AND DESCRIPTION	DRFT	CHKD
DIVISION	DIVISION CODE	DATE	DATE	DATE	DATE	DATE
	EMSD	JAN 21, 2015	JAN 21, 2015	JAN 21, 2015	JAN 21, 2015	JAN 21, 2015
DO NOT SCALE DRAWING	SCALE 4/1	TOLERANCES EXCEPT AS NOTED		INCHES		
				.00 ± .01		
				.000 ± .008		
				.0000 ±		
				MILLIMETERS		
				0 ± .3		
				.00 ± .20		
				.000 ±		
				ANGLES		
				MARKED ONLY		
3M		© 3M COPYR[IGHT] 2017		This document and the information it contains are 3M property and may not be reproduced or further distributed without 3M permission, or used or disclosed other than for 3M authorized purposes. All rights reserved.		
L 58601		AUG 11, 2016		JNC		RS
		8-11-16 ADD SHT 4		REVISE TRADEMAKING NOTE JUN 01, 2016		
		PRODUCTION RELEASE, APR 29, 2016				
TITLE		LATCH/EJECT HEADER, 2MM, STRAIGHT, RIGHT ANGLE & SMT				
CAGE NUMBER	SIZE	DRAWING NO.	REV.			
D		78-5100-2199-7	L			
MODEL	1552	DET	ISTS	YES	NO	SHT 1 OF 4

78-5100-2199-7  
 DRAWING NUMBER  
 1552  
 TIME5/17/2017UTC Offset

3M™ LATCH/EJECT HEADER, 1552 SERIES  
2MM X 2MM STRAIGHT & RIGHT ANGLE, THROUGH-HOLE, STRAIGHT & SURFACE MOUNT

STRAIGHT VERSION



ORDERING INFORMATION  
1552XX-6X0X-XX

CONTACT QUANTITY:  2  3  4

LATCHING OPTIONS:  
2 = LATCH, MOLDED-ON SOCKET WITH LATCHING EARS, SERIES: 870, 2MM  
3 = LATCH, PRESS-ON SOCKET, SERIES: 1522  
4 = LATCH, 2MM SCI CARRIER ONLY, SERIES: 93XX

PLATING OPTIONS:  
RB = 30µIN [.76µm] GOLD  
RA = 10µIN [.25µm] GOLD (RIA E1 & C1 APPLY) FOR BOTH PLATINGS

SOLDER TAIL LENGTH: DIMENSION "E"  
2 = .112 [2.84]  
3 = .155 [3.94]

STRAIGHT VERSION WITH INTERSTITIAL GROUNDS



ORDERING INFORMATION  
G1552XX-6X0X-XX

CONTACT QUANTITY:  2  3  4

LATCHING OPTIONS:  
4 = LATCH, 2MM SCI CARRIER ONLY, SERIES 93XX

PLATING OPTIONS:  
RB = 30µIN [.76µm] GOLD  
RA = 10µIN [.25µm] GOLD (RIA E1 & C1 APPLY) FOR BOTH PLATINGS

SOLDER TAIL LENGTH: DIMENSION "E"  
2 = .112 [2.84]

DESIGN REFERENCE	NEXT ASSEMBLY	REV	ECO	ISSUE DATE AND DESCRIPTION	DRFT	CHKD
DATE	DATE	DATE	DATE	DATE	DATE	DATE
CHKD	DATE	APPV	DATE	DATE	DATE	DATE
DIVISION	DIVISION CODE					
DO NOT SCALE DRAWING	SCALE 4/1	TOLERANCES EXCEPT AS NOTED INCHES .0 ±.01 .000 ±.008 .0000 ±.0000 MILLIMETERS 0 ±.3 .00 ±.20 .000 ±.000				
THIRD ANGLE PROJECTION	INTERPRET PER ASME Y14.5 - 2009	TITLE LATCH/EJECT HEADER, 2MM, STRAIGHT, RIGHT ANGLE & SMT				
MAX SURFACE ROUGHNESS	MARKED SURFACES	CAGE NUMBER	SIZE	DRAWING NO.	REV.	
MARKED ONLY	ANGLES	D		78-5100-2199-7	L	
		MODEL		1552	DET	ISTS <input type="checkbox"/> YES <input checked="" type="checkbox"/> NO <input type="checkbox"/> SHT 2 OF 4

78-5100-2199-7  
DRAWING NUMBER  
Revision  
Standard Time5/17/2017UTC Offset

**3M™ LATCH/EJECT HEADER, 1552 SERIES**  
 2MM X 2MM STRAIGHT & RIGHT ANGLE, THROUGH-HOLE, STRAIGHT & SURFACE MOUNT

**RIGHT ANGLE VERSION**

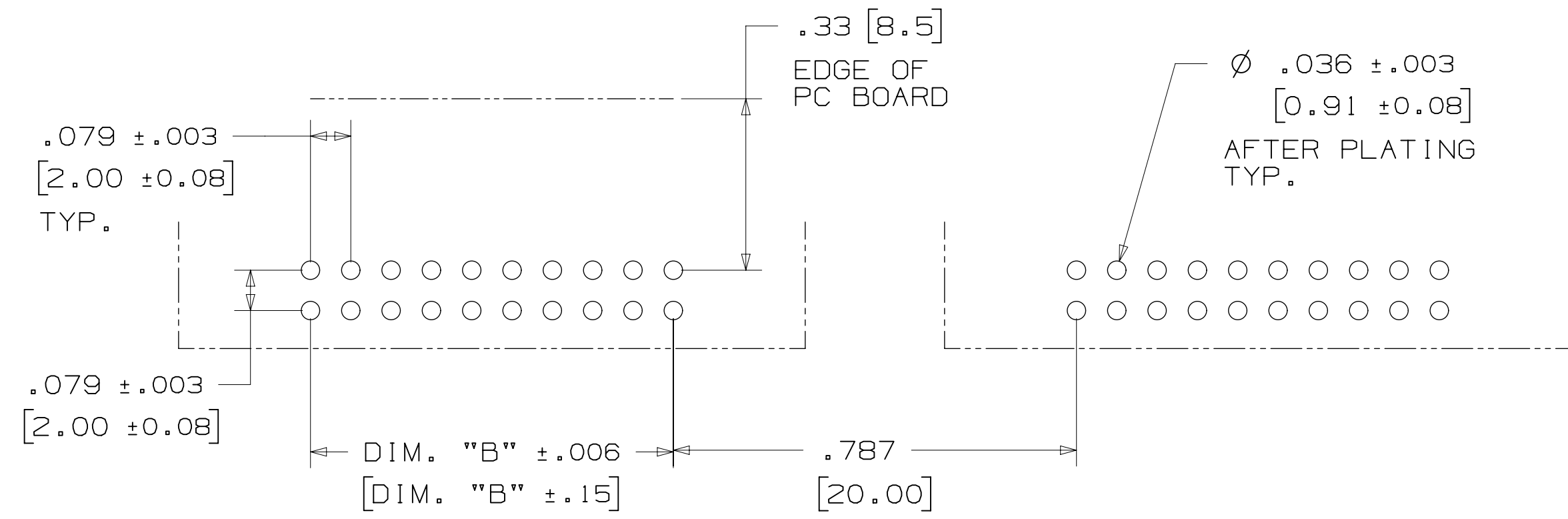
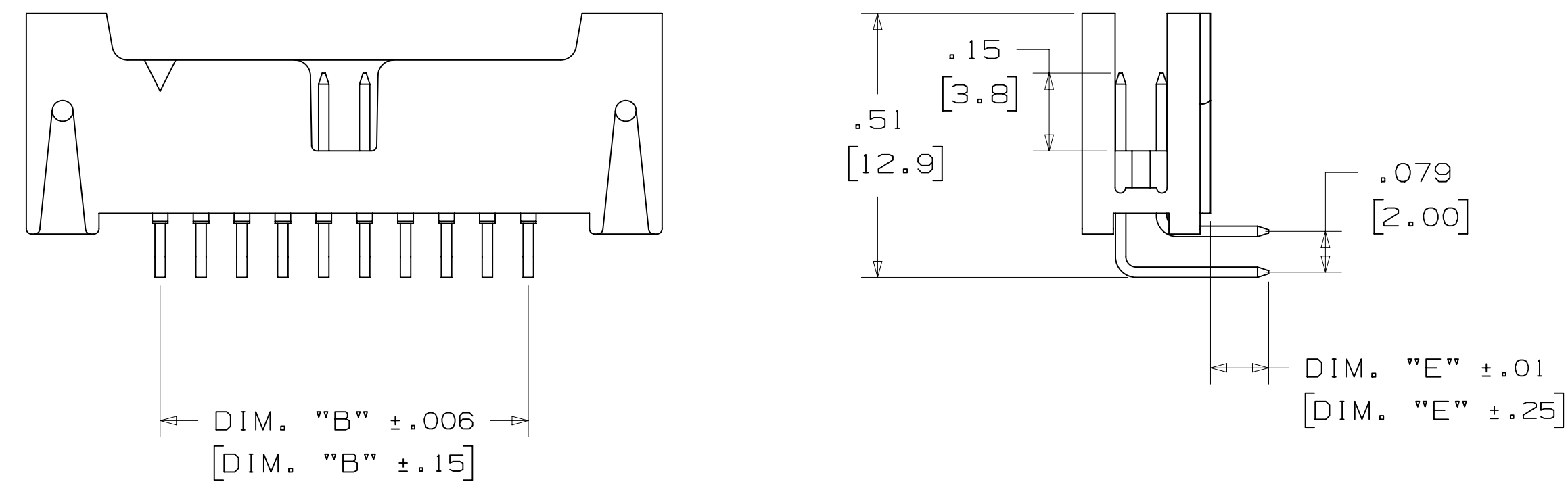

RECOMMENDED PC BOARD PATTERN  
 (VIEWED FROM CONNECTOR SIDE)

**ORDERING INFORMATION**

1552XX-5X0X-XX  
 CONTACT QUANTITY: \_\_\_\_\_

LATCHING OPTIONS:  
 2 = LATCH, MOLDED-ON SOCKET WITH LATCHING EARS, SERIES: 870, 2MM  
 3 = LATCH, PRESS-ON SOCKET, SERIES: 1522  
 4 = LATCH, 2MM SCI CARRIER ONLY, SERIES 93XX

PLATING OPTIONS:  
 RB = 30µIN [.76µm] GOLD  
 RA = 10µIN [.25µm] GOLD (RIA E1 & C1 APPLY) FOR BOTH PLATINGS

SOLDER TAIL LENGTH:  
 DIMENSION "E"  
 2 = .112 [2.84]  
 3 = .155 [3.94]

**SURFACE MOUNT VERSION**

NOTES:  
 1) TAPE & REEL PARTS ALWAYS SUPPLIED WITH VACUUM PICK-UP CAP.  
 2) TAPE & REEL NOT AVAILABLE WITH SCI LATCH OPTION.  
 3) TRAY PARTS SUPPLIED WITHOUT VACUUM PICK-UP CAP.

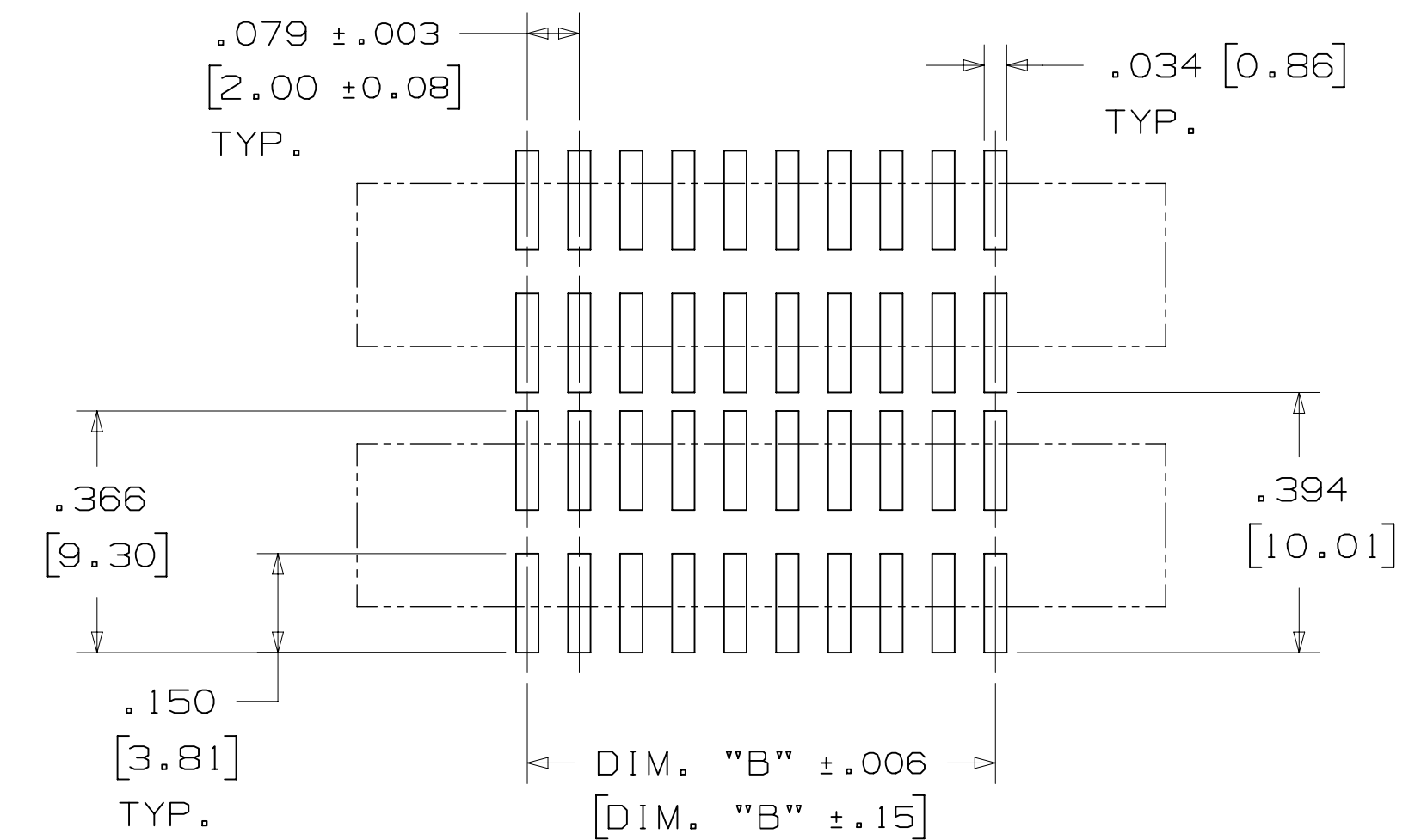
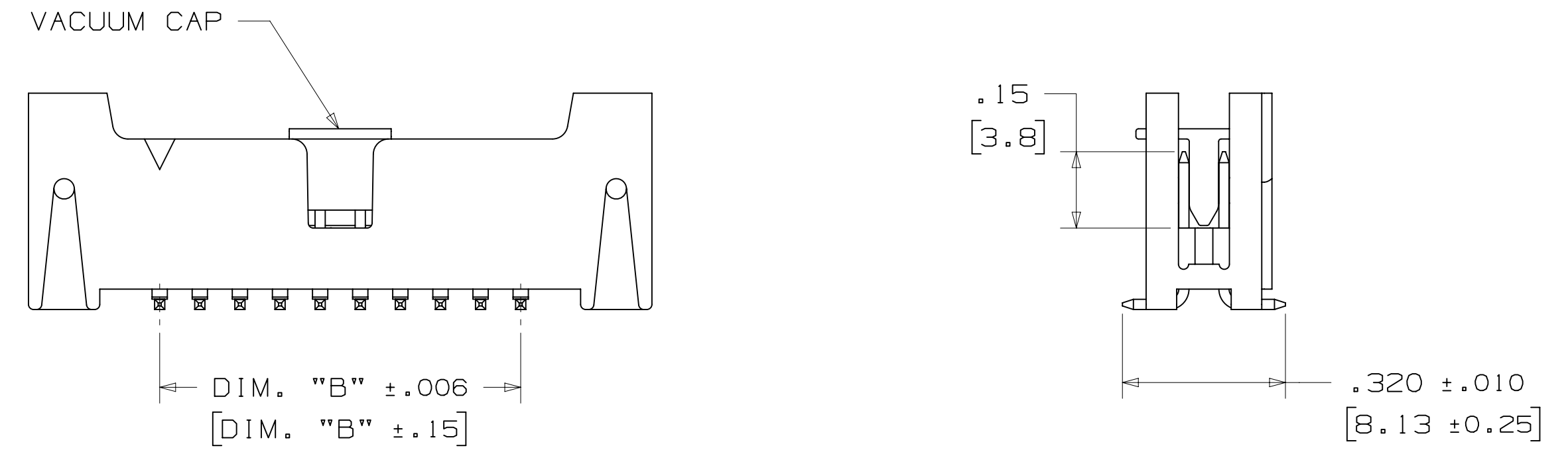

RECOMMENDED PC BOARD PATTERN  
 (VIEWED FROM CONNECTOR SIDE)

**ORDERING INFORMATION**

1552XX-2X00-XX-XX  
 CONTACT QUANTITY: \_\_\_\_\_

LATCHING OPTIONS:  
 2 = LATCH, MOLDED-ON SOCKET WITH LATCHING EARS, SERIES: 870, 2MM  
 3 = LATCH, PRESS-ON SOCKET, SERIES: 1522  
 4 = LATCH, 2MM SCI CARRIER ONLY, SERIES 93XX

PLATING OPTIONS:  
 RB = 30µIN [.76µm] GOLD  
 RA = 10µIN [.25µm] GOLD (RIA E1 & C1 APPLY) FOR BOTH PLATINGS

PACKAGING:  
 BLANK = TRAYS  
 WX = TAPE & REEL (SEE TABLE 1 ORDER CODE)

DESIGN REFERENCE	NEXT ASSEMBLY	REV	ECO	ISSUE DATE AND DESCRIPTION	DRFT	CHKD
DATE	DATE	DATE	DATE	DATE	DATE	DATE
CHKD	APPV	DATE	DATE	DATE	DATE	DATE
DIVISION		DIVISION CODE		DATE		
DO NOT SCALE DRAWING		SCALE		TOLERANCES EXCEPT AS NOTED		
THIRD ANGLE PROJECTION		INCHES		MILLIMETERS		
INTERPRET PER ASME Y14.5 - 2009		SURFACES		MARKED ONLY		
MAX SURFACE ROUGHNESS		SURFACES		MARKED ONLY		
MARKED ONLY		ANGLES		MARKED ONLY		
CAGE NUMBER		SIZE		DRAWING NO.		REV.
1552		D		78-5100-2199-7		L
MODEL		SHT		REV.		
1552		3 OF 4		REV.		

Imaged: L.6 Central Standard Time 5/17/2017 UTC OffSet

3M™ LATCH/EJECT HEADER, 1552 SERIES  
 2MM X 2MM STRAIGHT & RIGHT ANGLE, THROUGH-HOLE, STRAIGHT & SURFACE MOUNT

**Technical Information:** The technical information, recommendations and other statements contained in this document are based upon tests or experience that 3M believes are reliable, but the accuracy or completeness of such information is not guaranteed.

**Product Use:** Many factors beyond 3M's control and uniquely within user's knowledge and control can affect the use and performance of a 3M product in a particular application. Given the variety of factors that can affect the use and performance of a 3M product, user is solely responsible for evaluating the 3M product and determining whether it is fit for a particular purpose and suitable for user's method of application.

**Warranty, Limited Remedy, and Disclaimer:** Unless an additional warranty is specifically stated on the applicable 3M product packaging or product literature, 3M warrants that each 3M product meets the applicable 3M product specification at the time 3M ships the product. 3M MAKES NO OTHER WARRANTIES OR CONDITIONS, EXPRESS OR IMPLIED, INCLUDING, BUT NOT LIMITED TO, ANY IMPLIED WARRANTY OR CONDITION OF MERCHANTABILITY OR FITNESS FOR A PARTICULAR PURPOSE OR ANY IMPLIED WARRANTY OR CONDITION ARISING OUT OF A COURSE OF DEALING, CUSTOM OR USAGE OF TRADE. If the 3M product does not conform to this warranty, then the sole and exclusive remedy is, at 3M's option, replacement of the 3M product or refund of the purchase price.

**Limitation of Liability:** Except where prohibited by law, 3M will not be liable for any loss or damage arising from the 3M product, whether direct, indirect, special, incidental or consequential, regardless of the legal theory asserted, including warranty, contract, negligence or strict liability.

Unless otherwise noted, references to industry specifications are intended to indicate substantial compliance to the material elements of the specification. Such references should not be construed as a guarantee of compliance to all requirements in a given specification.

DESIGN REFERENCE	NEXT ASSEMBLY	REV	ECO	ISSUE DATE AND DESCRIPTION	DRFT	CHKD
				AUG 11, 2016	JNC	RS
				8-11-16 ADD SHT 4		
				REVISE TRADEMAKE NOTE		
				JUN 01, 2016		
				PRODUCTION RELEASE,		
				APR 29, 2016		
NAME	DATE	DATE	DATE	DATE	DATE	DATE
CASTIGLIONE	JAN 21, 2015	MFG				
CHKD	DATE	APPRV	DATE	DATE	DATE	DATE
		R. SCHERER	JAN 21, 2015			
DIVISION	DIVISION CODE	 3M Center St. Paul, MN 55144				
	EMSD	© 3M COPYRIGHT 2017 This document and the information it contains are 3M property and may not be reproduced or further distributed without 3M permission, or used or disclosed other than for 3M authorized purposes. All rights reserved.				
DO NOT SCALE DRAWING	SCALE 1/1	TOLERANCES EXCEPT AS NOTED		TITLE		
		INCHES		LATCH/EJECT HEADER,		
		.00 ± .01		2MM, STRAIGHT, RIGHT		
		.000 ± .008		ANGLE & SMT		
		.0000 ±				
THIRD ANGLE PROJECTION		MILLIMETERS		CAGE NUMBER		
		0 ±		D 78-5100-2199-7		
		.0 ± .3		DRAWING NO.		
		.00 ± .20		L		
		.000 ±		REV.		
MAX SURFACE ROUGHNESS		MARKED ONLY		MODEL		
1552				1552		
				DET		
				LISTS		
				YES		
				NO		
				SHT 4 OF 4		

78-5100-2199-7  
 DRAWING NUMBER  
 1552  
 Standard Time5/17/2017UTC Offrset



Компания «ЭлектроПласт» предлагает заключение долгосрочных отношений при поставках импортных электронных компонентов на взаимовыгодных условиях!

Наши преимущества:

- Оперативные поставки широкого спектра электронных компонентов отечественного и импортного производства напрямую от производителей и с крупнейших мировых складов;
- Поставка более 17-ти миллионов наименований электронных компонентов;
- Поставка сложных, дефицитных, либо снятых с производства позиций;
- Оперативные сроки поставки под заказ (от 5 рабочих дней);
- Экспресс доставка в любую точку России;
- Техническая поддержка проекта, помощь в подборе аналогов, поставка прототипов;
- Система менеджмента качества сертифицирована по Международному стандарту ISO 9001;
- Лицензия ФСБ на осуществление работ с использованием сведений, составляющих государственную тайну;
- Поставка специализированных компонентов (Xilinx, Altera, Analog Devices, Intersil, Interpoint, Microsemi, Aeroflex, Peregrine, Syfer, Eurofarad, Texas Instrument, Miteq, Cobham, E2V, MA-COM, Hittite, Mini-Circuits, General Dynamics и др.);

Помимо этого, одним из направлений компании «ЭлектроПласт» является направление «Источники питания». Мы предлагаем Вам помощь Конструкторского отдела:

- Подбор оптимального решения, техническое обоснование при выборе компонента;
- Подбор аналогов;
- Консультации по применению компонента;
- Поставка образцов и прототипов;
- Техническая поддержка проекта;
- Защита от снятия компонента с производства.



#### Как с нами связаться

**Телефон:** 8 (812) 309 58 32 (многоканальный)

**Факс:** 8 (812) 320-02-42

**Электронная почта:** [org@eplast1.ru](mailto:org@eplast1.ru)

**Адрес:** 198099, г. Санкт-Петербург, ул. Калинина, дом 2, корпус 4, литера А.