

SMD 360.0MHz SAW FILTER



5.0 x 5.0 x 1.5mm

AFS360.0N01-SE



RoHS
Compliant

FEATURES:

- Low loss 6dB max
- 5.0 x 5.0 x 1.5mm seam sealed package
- Suitable for RoHS reflow profile

APPLICATIONS:

- Telecommunication

STANDARD SPECIFICATIONS:

ABSOLUTE MAXIMUM RATING

DC Permissive Voltage	10V DC max.
Operating Temperature Range	-30°C to +80°C
Storage Temperature Range	-45°C to +85°C
Source Power	0dBm

ELECTRICAL CHARACTERISTICS

Item	Units	Minimum	Typical	Maximum
Center Frequency (f_0)	MHz	--	360.0	--
Pass-band Width	KHz	--	315.0	--
Minimum Insertion Loss	dB	--	3.8	5.0
Ripple Deviation (Pass-band)				
$f_0 \pm 67.7\text{KHz}$	dB	--	0.6	2.0
$f_0 \pm 80.0\text{KHz}$	dB	--	0.9	3.0
Group Delay Ripple				
$f_0 \pm 67.7\text{KHz}$	μsec	--	0.5	1.8
Stop Band Suppression				
$f_0 - 30.0\text{MHz} \sim f_0 - 5.0\text{MHz}$	dB	55.0	62.0	--
$f_0 - 5.0\text{MHz} \sim f_0 - 1.6\text{MHz}$	dB	52.0	54.0	--
$f_0 - 1.6\text{MHz} \sim f_0 - 800\text{KHz}$	dB	42.0	48.0	--
$f_0 - 800\text{KHz} \sim f_0 - 600\text{KHz}$	dB	38.0	48.0	--
$f_0 - 600\text{KHz} \sim f_0 - 400\text{KHz}$	dB	24.0	32.0	--
$f_0 + 400\text{KHz} \sim f_0 + 600\text{KHz}$	dB	24.0	32.0	--
$f_0 + 600\text{KHz} \sim f_0 + 800\text{KHz}$	dB	38.0	48.0	--
$f_0 + 800\text{KHz} \sim f_0 + 1.6\text{MHz}$	dB	42.0	48.0	--
$f_0 + 1.6\text{MHz} \sim f_0 + 5.0\text{MHz}$	dB	*52.0	54.0	--
$f_0 + 5.0\text{MHz} \sim f_0 + 30.0\text{MHz}$	dB	55.0	62.0	--
Impedance within the pass band				
Input: $Z_{IN} = R_{IN}/C_{IN}$	$\Omega//\text{pF}$	--	340//1.9	--
Output: $Z_{OUT} = R_{OUT}/C_{OUT}$	$\Omega//\text{pF}$	--	340//1.9	--
Temperature coefficient of frequency	Ppm/K^2	--	-0.036	--

*This value is not including the spurious response in the frequency range from 362.5MHz to 364.0MHz

TEST CIRCUIT:

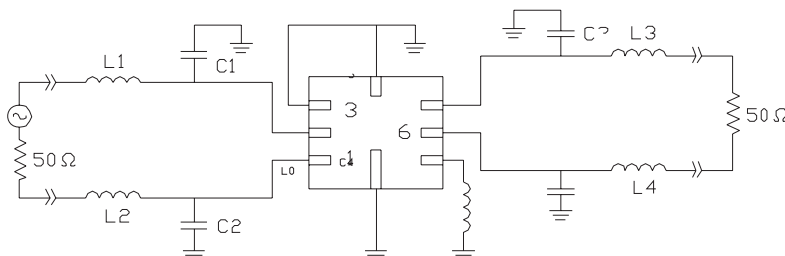

$L1 = L2 = L3 = L4 = 18\text{nH}$
 $L0 = 68\text{nH}$
 $C1 = C2 = C3 = C4 = 1.2\text{pF}$



SMD 360.0MHz SAW FILTER

AFS360.0N01-SE



RoHS
Compliant



5.0 x 5.0 x 1.5mm

FREQUENCY CHARACTERISTICS:

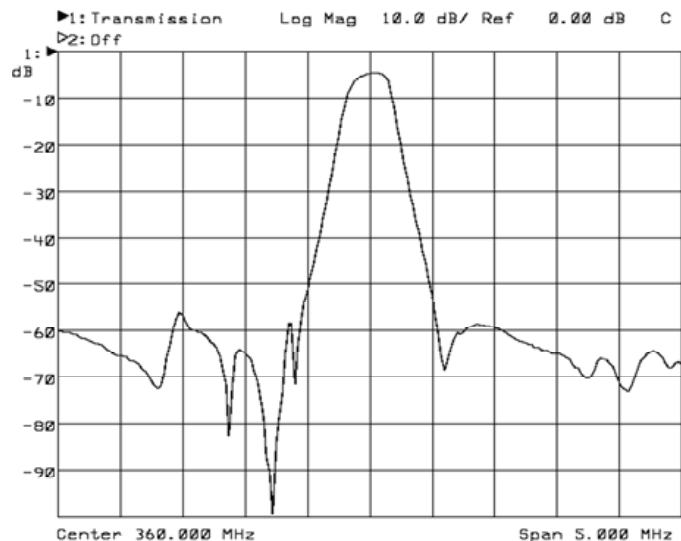

OUTLINE DIMENSIONS:

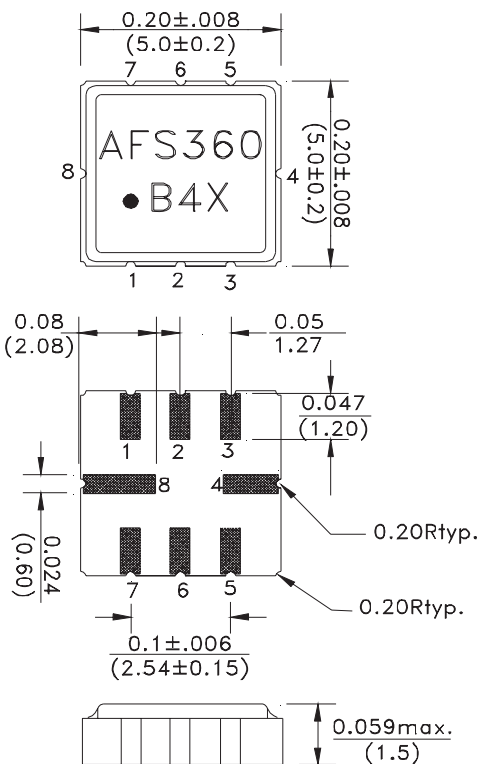

B Month code 4 Last figure of year

Month	1	2	3	4	5	6	7	8	9	10	11	12
Month code	A	B	C	D	E	F	G	H	I	J	K	L

e.g.: "B4" means February of 2004

X = Traceability Code

Pin No.	Function
1	Input Ground
2	Input
3	Ground
4	Case Ground
5	Output
6	Output Ground
7	Ground
8	Case Ground

Unit: inch (mm)



SMD 360.0MHz SAW FILTER



5.0 x 5.0 x 1.5mm

AFS360.0N01-SE



RoHS
Compliant

TAPE & REEL:

Taping Structure

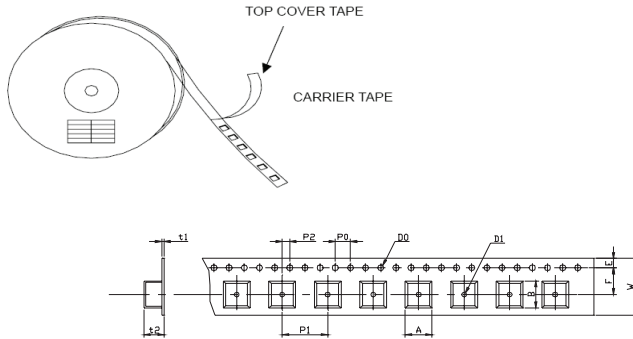

Leader part and vacant position specification

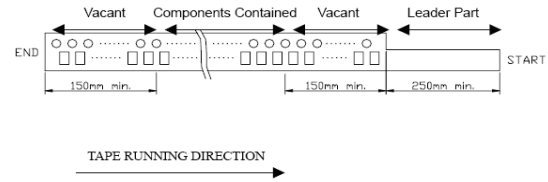

W	F	E	P0	P1	P2	D0	D1	t1	t2	A	B
12.0	5.5	1.75	4.0	8.0	2.0	Φ 1.5	Φ 1.5	0.31	1.95	5.5	5.5
±0.3	±0.1	±0.1	±0.2	±0.1	±0.2	±0.1	±0.25	max.	max.	max.	max.

TAPE SPECIFICATIONS

- Tensile Strength of carrier tape: 4.4N/mm width.
- Top Cover Tape Adhesion
 - 1) pull off angle: 0~15°
 - 2) speed: 300mm/min.
 - 3) force 20~70g

Device Name	
Type	
Quantity	
Lot No.	

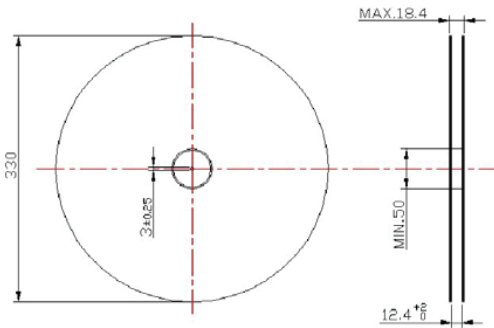

REFLOW PROFILE:

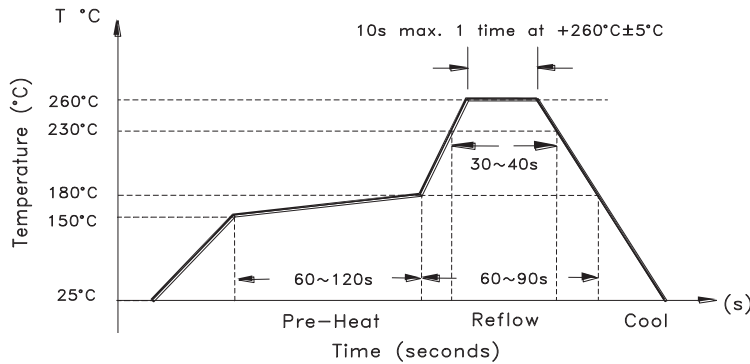

ATTENTION: Abracon Corporation's products are COTS – Commercial-Off-The-Shelf products; suitable for Commercial, Industrial and, where designated, Automotive Applications. Abracon's products are not specifically designed for Military, Aviation, Aerospace, Life-dependant Medical applications or any application requiring high reliability where component failure could result in loss of life and/or property. For applications requiring high reliability and/or presenting an extreme operating environment, written consent and authorization from Abracon Corporation is required. Please contact Abracon Corporation for more information.

ABRACON IS
ISO9001:2008
CERTIFIED



ABRACON
CORPORATION

Visit www.abracon.com for Terms & Conditions of Sale **Revised: 09.19.12**
30332 Esperanza, Rancho Santa Margarita, California 92688
tel 949-546-8000 | fax 949-546-8001 | www.abracon.com



Компания «ЭлектроПласт» предлагает заключение долгосрочных отношений при поставках импортных электронных компонентов на взаимовыгодных условиях!

Наши преимущества:

- Оперативные поставки широкого спектра электронных компонентов отечественного и импортного производства напрямую от производителей и с крупнейших мировых складов;
- Поставка более 17-ти миллионов наименований электронных компонентов;
- Поставка сложных, дефицитных, либо снятых с производства позиций;
- Оперативные сроки поставки под заказ (от 5 рабочих дней);
- Экспресс доставка в любую точку России;
- Техническая поддержка проекта, помощь в подборе аналогов, поставка прототипов;
- Система менеджмента качества сертифицирована по Международному стандарту ISO 9001;
- Лицензия ФСБ на осуществление работ с использованием сведений, составляющих государственную тайну;
- Поставка специализированных компонентов (Xilinx, Altera, Analog Devices, Intersil, Interpoint, Microsemi, Aeroflex, Peregrine, Syfer, Eurofarad, Texas Instrument, Miteq, Cobham, E2V, MA-COM, Hittite, Mini-Circuits, General Dynamics и др.);

Помимо этого, одним из направлений компании «ЭлектроПласт» является направление «Источники питания». Мы предлагаем Вам помощь Конструкторского отдела:

- Подбор оптимального решения, техническое обоснование при выборе компонента;
- Подбор аналогов;
- Консультации по применению компонента;
- Поставка образцов и прототипов;
- Техническая поддержка проекта;
- Защита от снятия компонента с производства.



Как с нами связаться

Телефон: 8 (812) 309 58 32 (многоканальный)

Факс: 8 (812) 320-02-42

Электронная почта: org@eplast1.ru

Адрес: 198099, г. Санкт-Петербург, ул. Калинина, дом 2, корпус 4, литера А.