

Description

The SVS04 power distribution system for symmetrical DIN rail mounting is designed to distribute power from a switch-mode power supply to 4 or 8 channels. Selective protection of the load output circuits is provided by the plug-in type circuit breakers installed. With a max. load current of 8A per channel and a max. total current of 40A the SVS04 provides ease of wiring in short circuit current limited DC24V applications. Five protected "L+" load outputs per way and 15 or 30 minus terminals significantly reduce wiring time enormously.

Electronic circuit breaker ESS20-003, electronic circuit protector ESX10-103 and thermal-magnetic circuit breakers 2210-S21 are all suitable for use with the SVS04, plugging directly into the sockets provided for each of the 4 or 8 outputs.

Ordering information

Type

- SVS04** power distribution system for types ESS20-003, ESX10-103, 2210-S21
- for short circuit current limited DC 24 V applications
 - max. 40 A continuous load
 - one integral circuit breaker (CB1): overcurrent protection of group signalisation, red LED flashes upon trip of CB1
 - including 1 insulated wire bridge Y 303 881 08
 - accessories: jumper SB-S11-P1-01-1-1A
for unused ways, please order separately

Version, max. number of circuit breakers on the power distribution system

- 04** 4 circuit breakers F1...F4
- 08** 8 circuit breakers (F1...F8)

Fitted versions

- B10** standard: fitted with screwless spring-loaded terminals (max. 2.5 mm², without wire end ferrule)
- B20** fitted with plug-in type screw terminals (max. 2.5 mm², without wire end ferrule)
- C10** fitted with pcb terminals, spring-loaded terminals (max. 2.5 mm², without wire end ferrule)

Minus terminals

- 15 minus terminals
- K01** 30 minus terminals (only for SVS04-08)

Special marking

- SB01** with marked terminals
entry line +++/---
remaining terminals 1/2/3/4/5

SVS04 - 04 - B10 - K01 - SB01

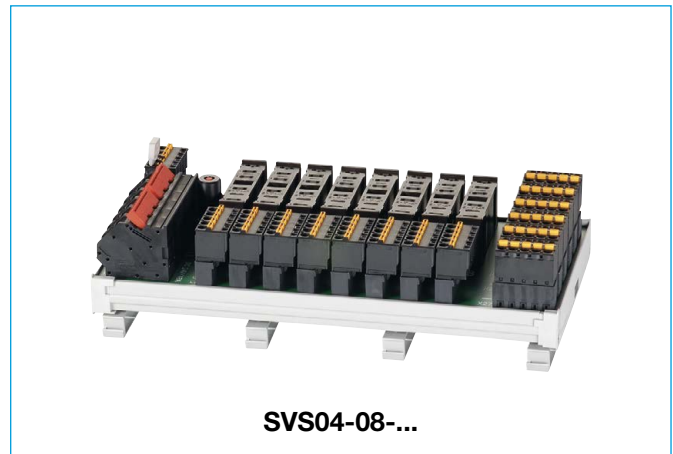

Technical data

DC 24 V supply

DC 24 V terminals, 2x3 terminals (screwless terminals max. 10 mm²), for current supply

- DC 24 V (+) = (X21) +/+/+
- DC 24 V (-) = (X21) -/-/-

Integral loop-through, for wiring and additional connection of an external buffer module.

F positions

Number of ways for circuit breakers, suitable for types ESS20-003, ESX10-103, 2210-S21

- SVS04-04... F1...F4 = terminals X1...X4
- SVS04-08... F1...F8 = terminals X1...X8

Plug jumper SB-S11-P1-01-1-1A into unused ways (please order separately, see accessories)

Load outputs

5 x L+ protected per position F1...F4 (F1...F8), led through terminals X1...X4 (X1...X8), max. 2.5 mm² load current max. 8 A per position

Signalisation

signalisation terminal X31, 5-pole, max. 2.5 mm²

- +: DC 24 V feed from terminal X21, protected by integral circuit breaker CB1
total current max. 0.5 A
group signalisation:
- S: line feed DC 24 V, insert insulated wire bridge Y 303 881 08 (bulk shipped) between + and GR
- AS: output of group signalisation
two-group signalisation
- GR: line feed, insert insulated wire bridge Y 303 881 08 (bulk shipped) between + and GR
- AS: output group A (X5...X8)
- B: output group B (X1...X4)

Minus terminals

3 x 5 terminals (X22, X23, X24) or
6 x 5 terminals (X22, X23, X24, X25, X26, X27): version K01

Termination

For signalisation, load outputs and minus terminals:

- B10: screwless spring-loaded terminals max. 2.5 mm², with integral test socket
- B20: plug-in type screw terminals max 2.5 mm², with integral test socket
- C10: pcb terminal/spring-loaded terminal max. 2.5 mm², with integral test socket

General data

- protection class to DIN 40050: IP20
- insulation co-ordination to IEC 60934: 0.5 kV
- pollution degree 2
- dielectric strength AC 500 V
- temperature range: 0...50 °C (without condensation)
- for symmetrical DIN rail mounting EN50022 – 35 x 7.5
- dimensions: see dimensional drawings

Wiring example: SVS04-04... with ESS20-003 and group signalisation

Signal path of group signalisation from F1 to F4

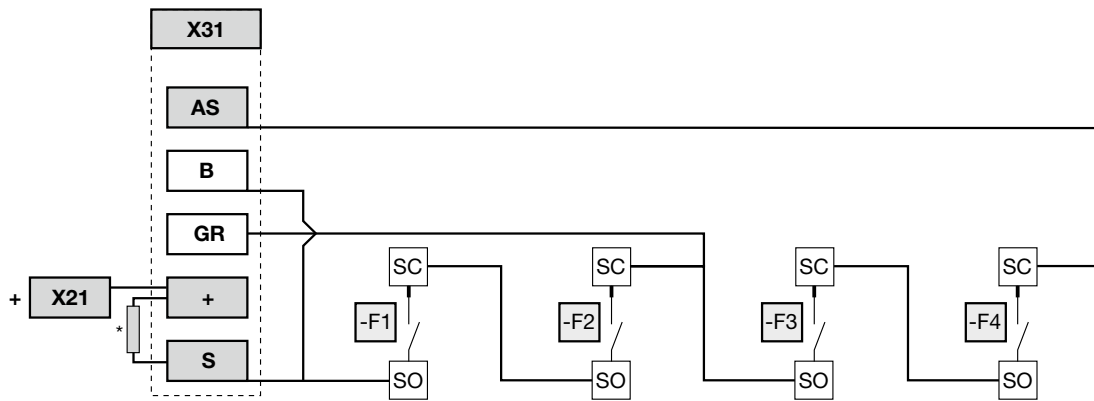

- X 31** **signalisation terminal**
- AS signal output group signal
- + +DC 24 V from terminal 21, internally prewired and protected by CB1
- S line feed group signalisation with insulation bridge*
- SC / SO auxiliary contact ESS20-003, make contact

Wiring example: SVS04-08... with ESS20-003 and group signalisation

Signal path of group signalisation from F1 to F8

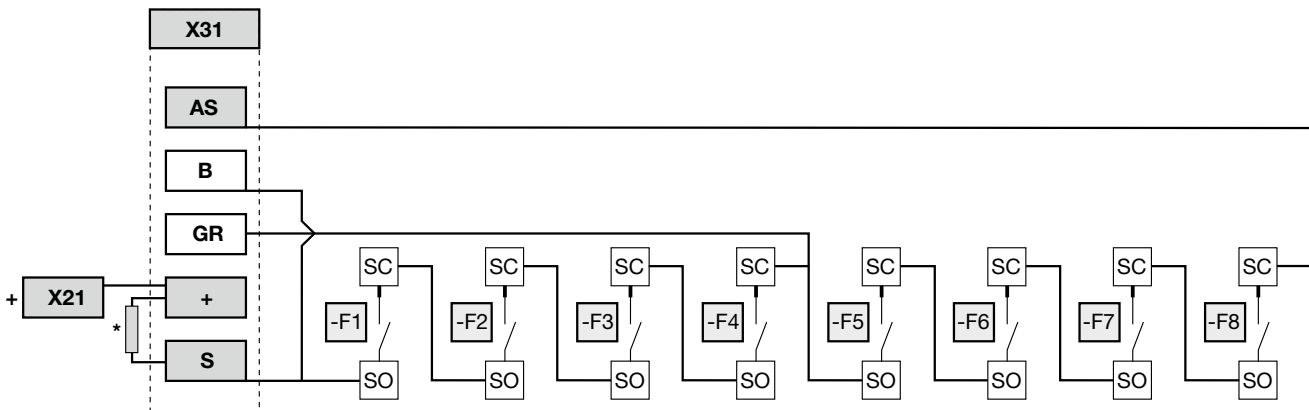

- X 31** **signalisation terminal**
- AS signal output group signal
- + +DC 24 V from terminal 21, internally prewired and protected by CB1
- S line feed group signalisation with insulation bridge*
- SC / SO auxiliary contact ESS20-003, make contact

6

Wiring example: SVS04-04... with ESS20-003 and two-group signalisation

Signal path of two-group signalisation
from F1 to F2 = group B, from F3 to F4 = group A

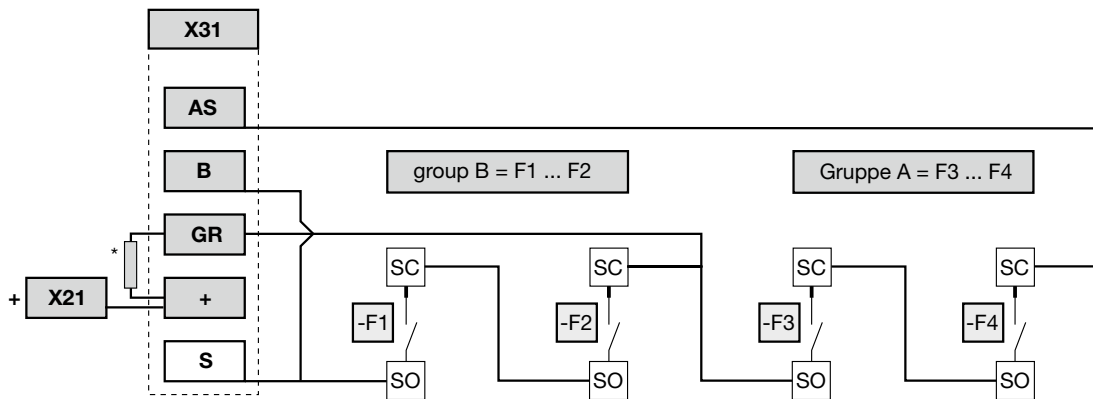

- X31** signalisation terminal
- AS signal output group A (F3 ... F4)
- B signal output group B (F1 ... F2)
- + +DC 24 V from terminal 21, internally prewired and protected by CB1
- GR line feed two-group signalisation with insulation bridge*
- SC/SO auxiliary contact ESS20-003, make contact

Wiring example: SVS04-08... with ESS20-003 and two-group signalisation

Signal path of two-group signalisation
from F1 to F4 = group B, from F5 to F8 = group A

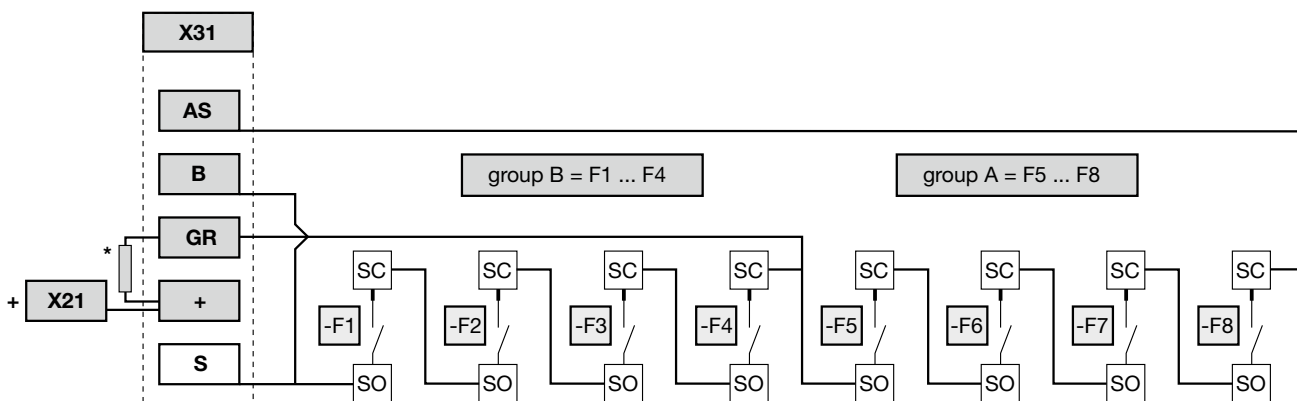

- X31** signalisation terminal
- AS signal output group A (F5 ... F8)
- B signal output group B (F1 ... F4)
- + +DC 24 V from terminal 21, internally prewired and protected by CB1
- GR line feed two-group signalisation with insulation bridge*
- SC/SO auxiliary contact ESS20-003, make contact

Dimensions SVS04-04-... (with 15 minus terminals)

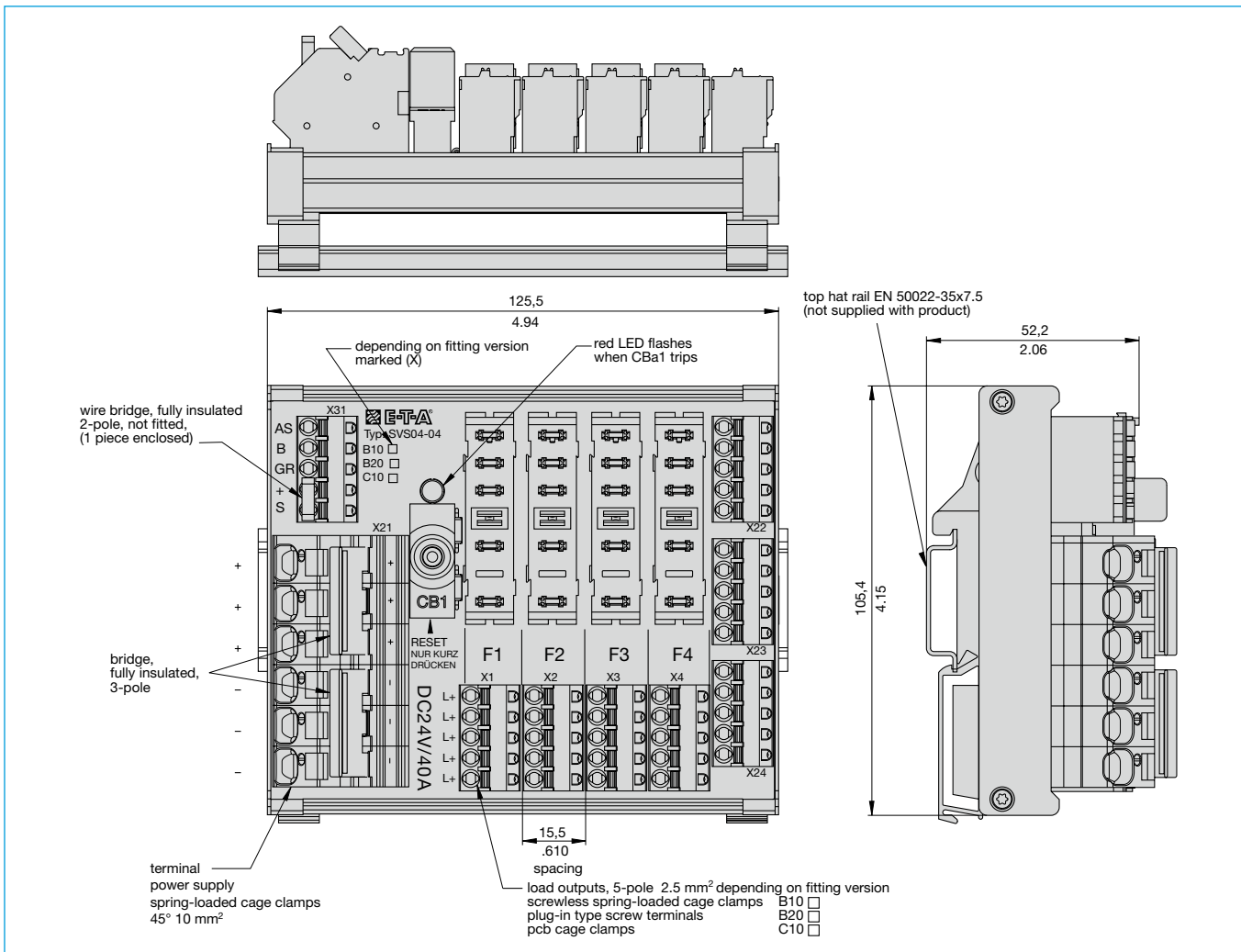

Schematic diagram SVS04-04-... (fitted with ESS20-003)

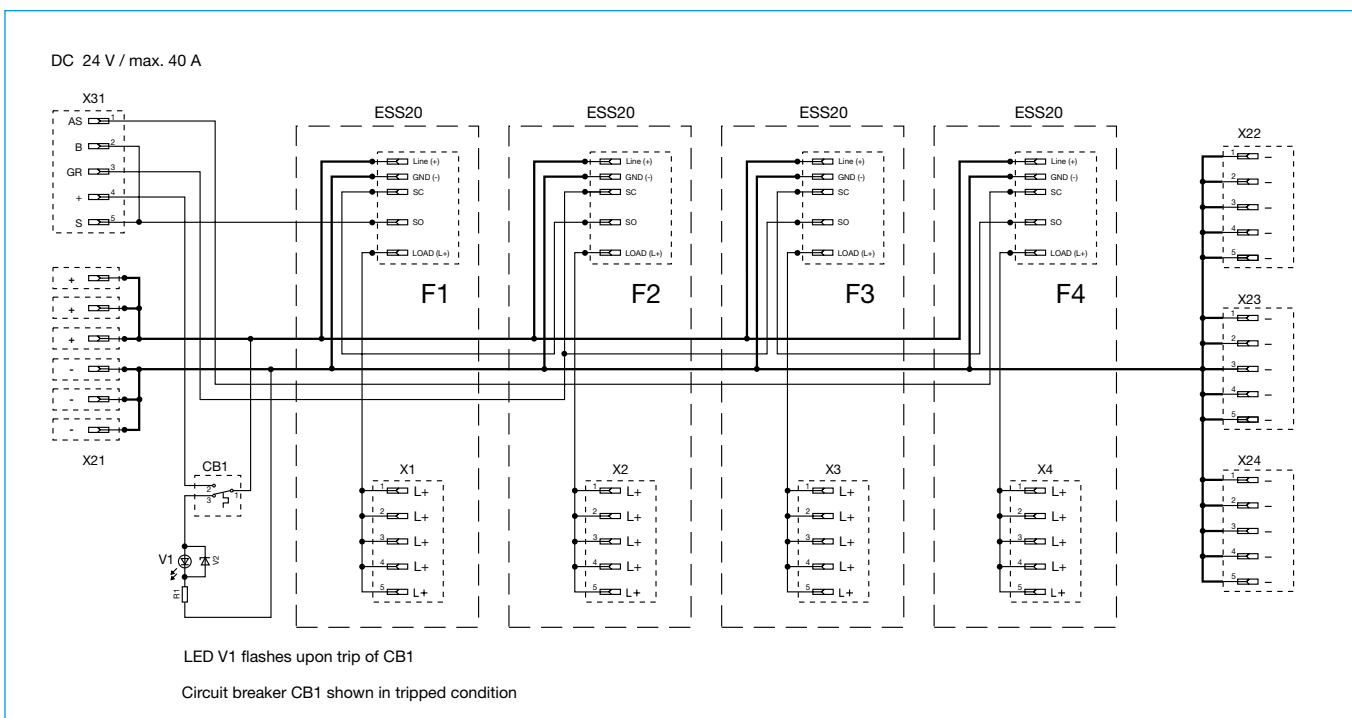

6

Dimensions SVS04-04-..., fitted with ESS20-003

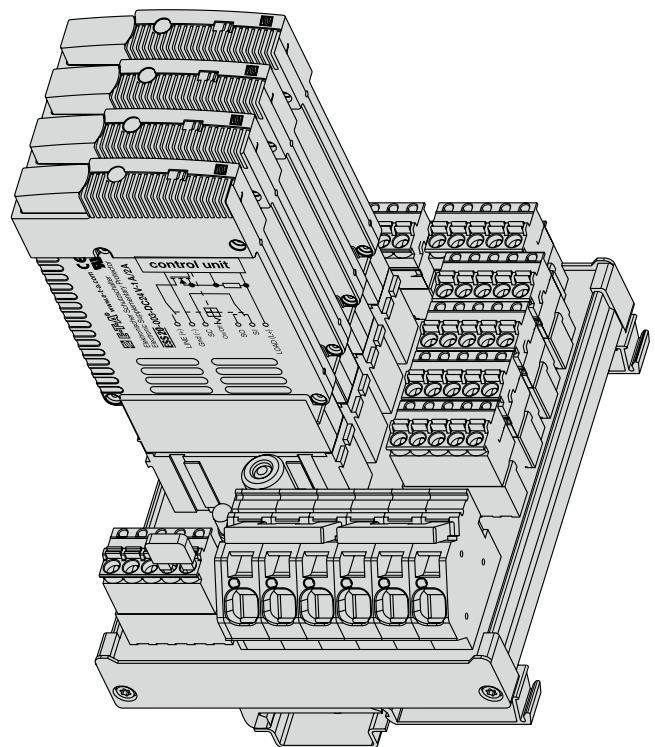
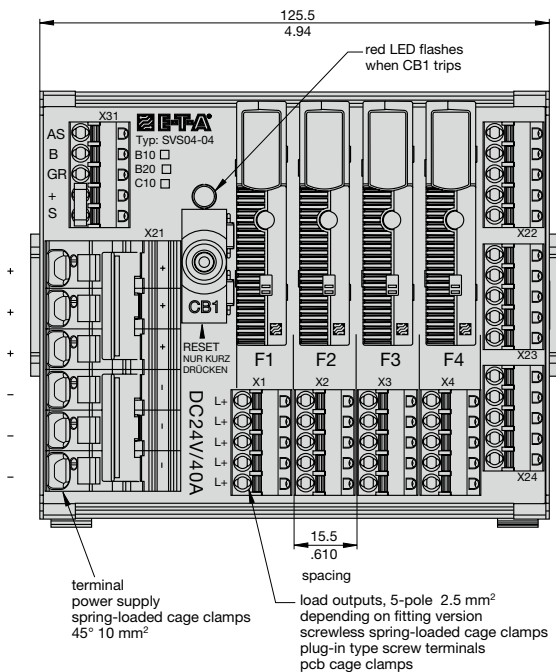
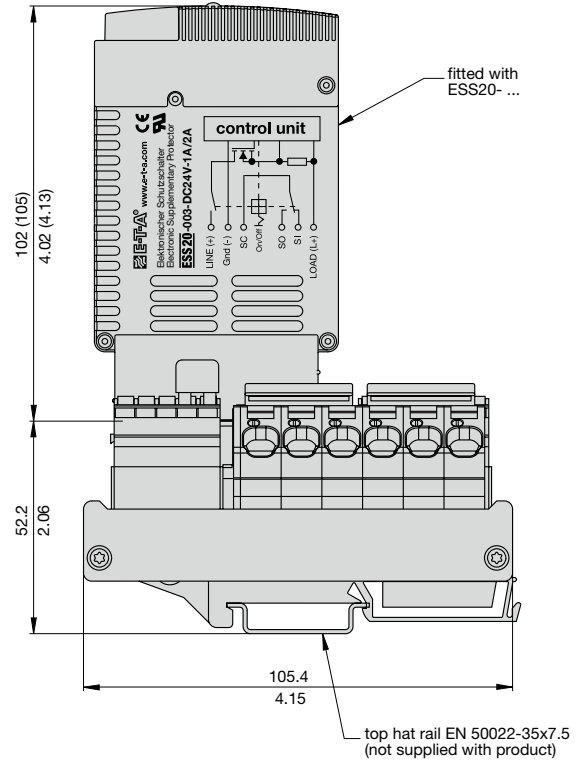
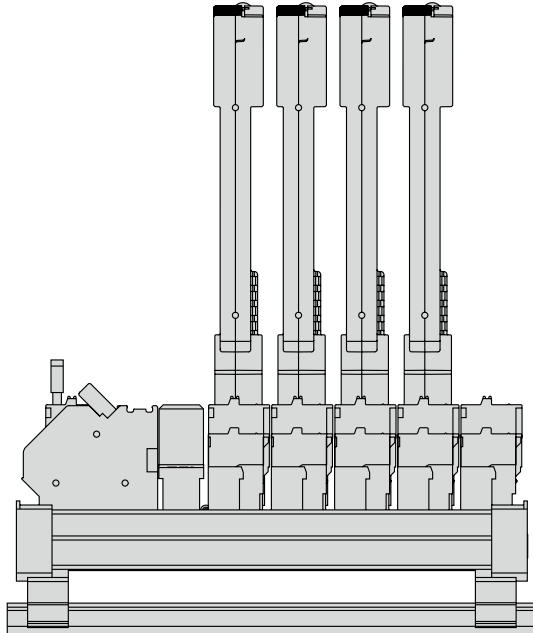

This is a metric design and millimeter dimensions take precedence ($\frac{mm}{inch}$)

Dimensions SVS04-08-... (with 15 minus terminals)

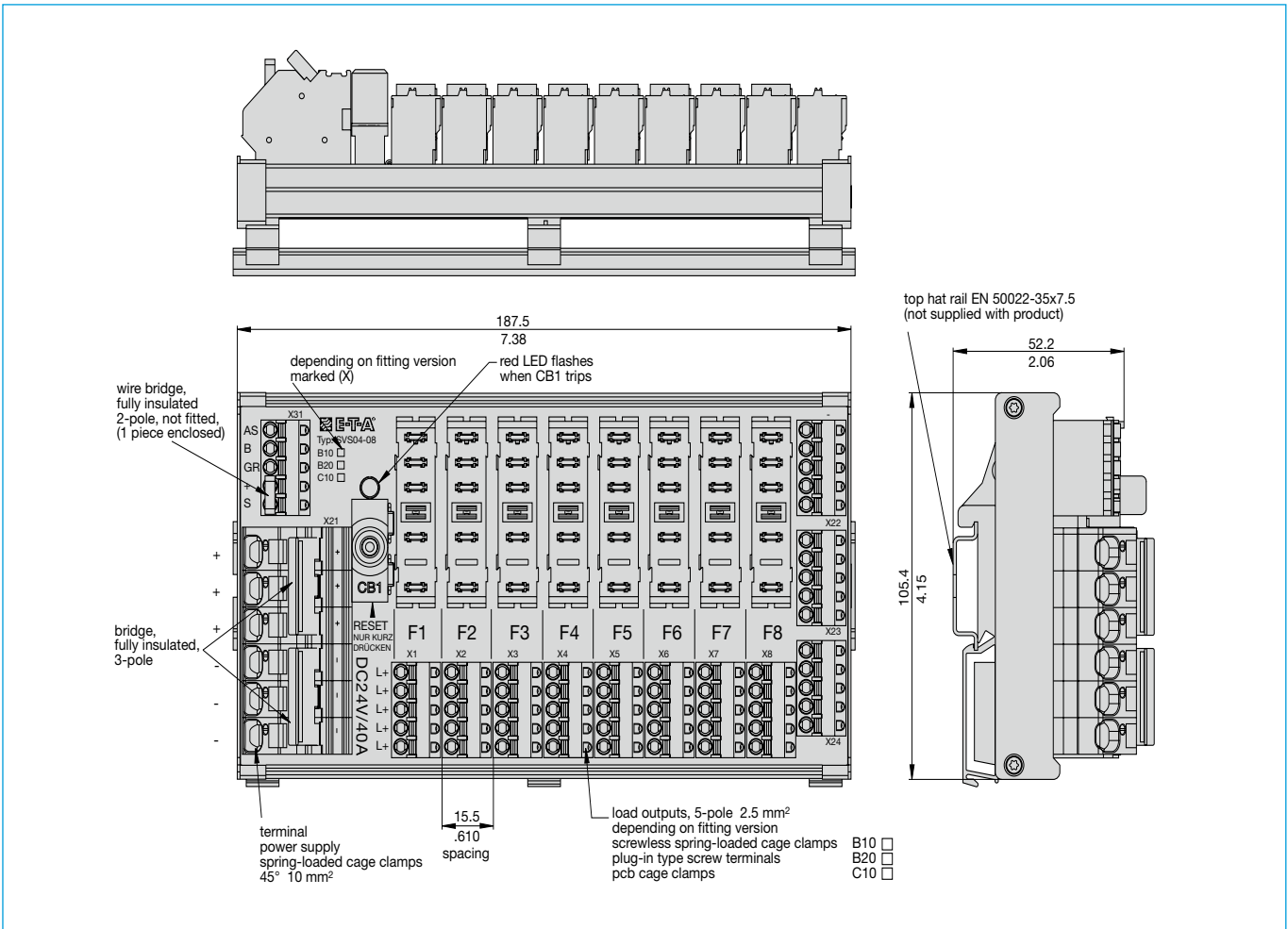

Dimensions SVS04-08... K01 (with 30 minus terminals)

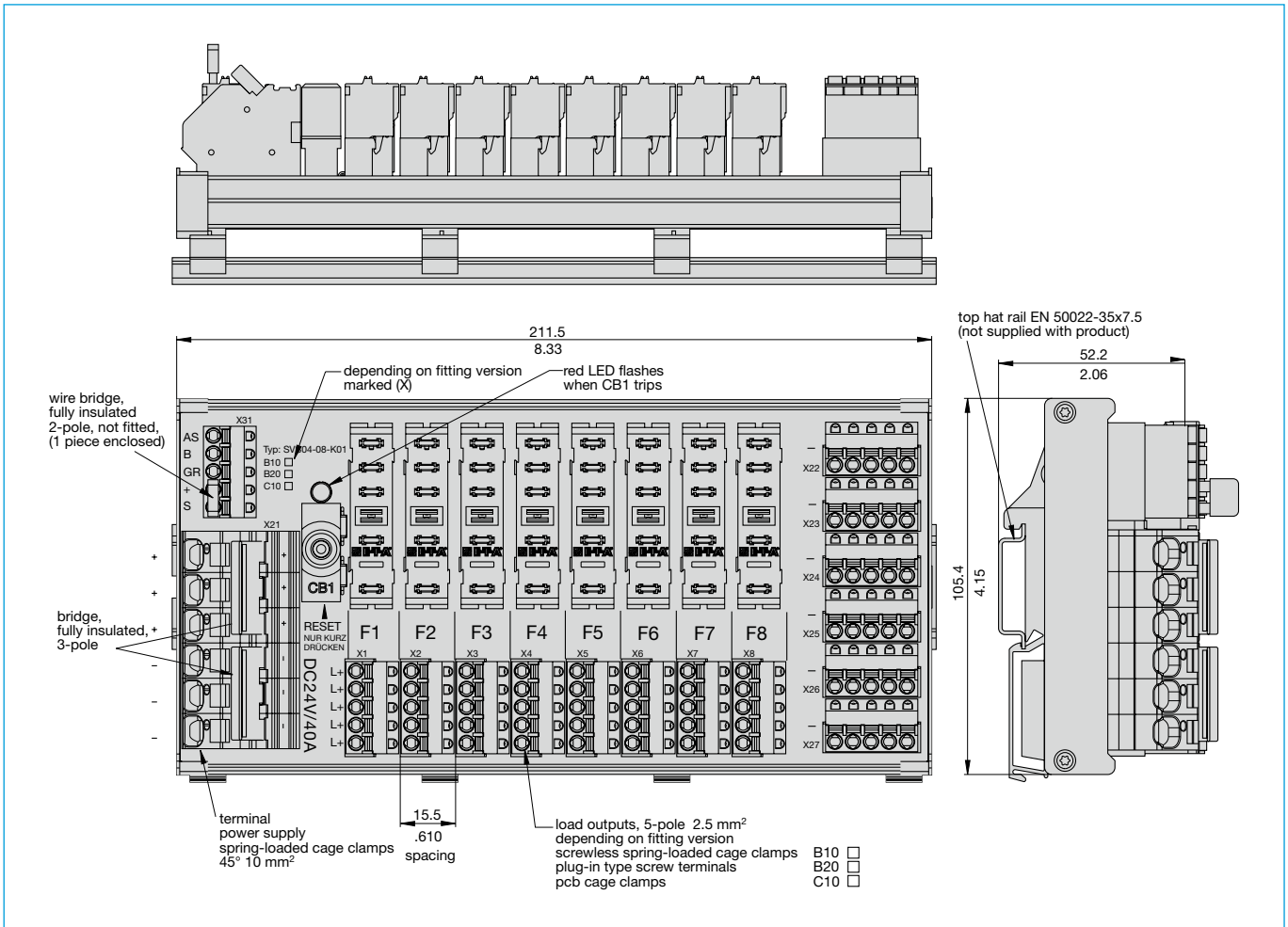

Schematic diagram SVS04-08... K01 (fitted with ESS20-003)

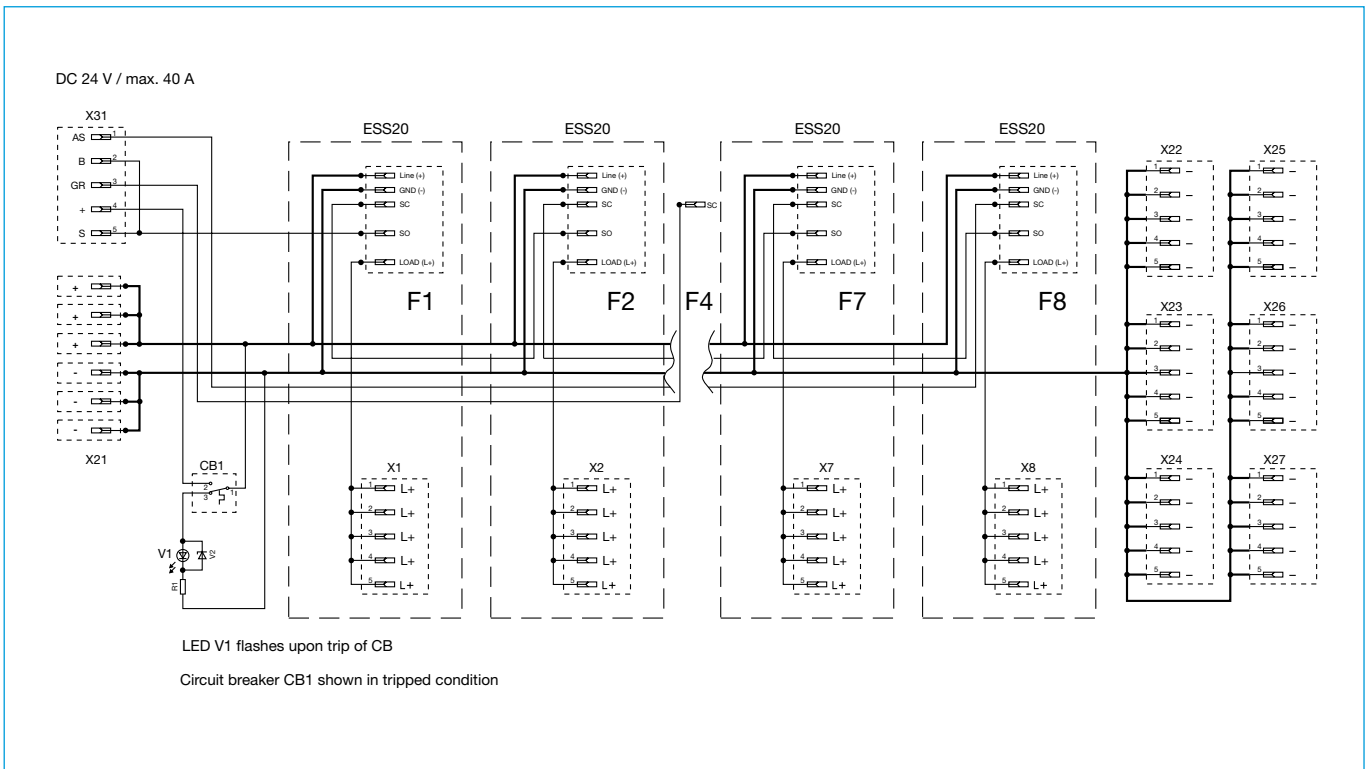

Dimensions SVS04-08... K01, fitted with ESX10-103

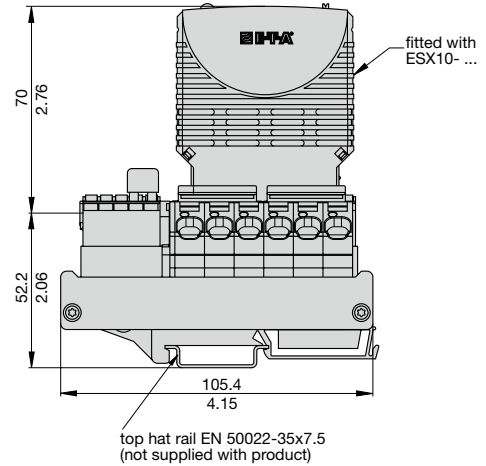
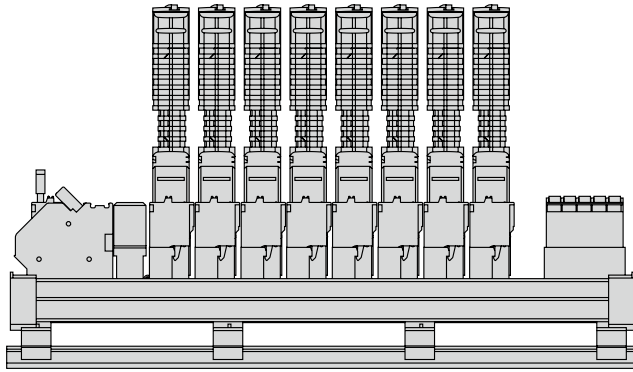

wire bridge, fully insulated 2-pole, not fitted, (1 piece enclosed)

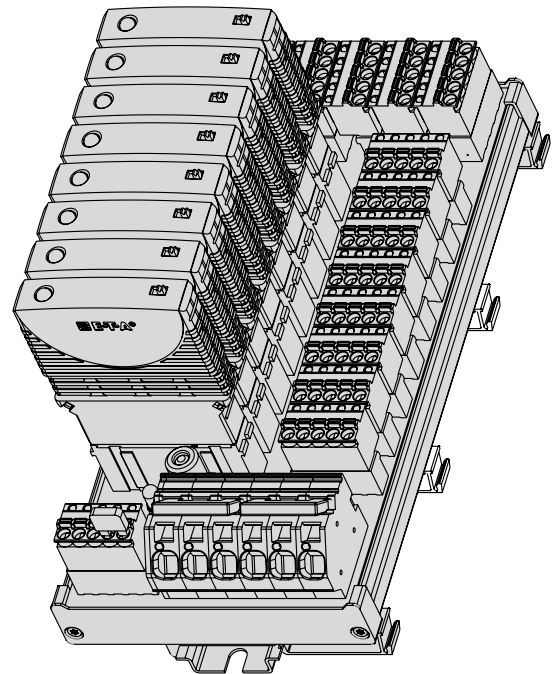
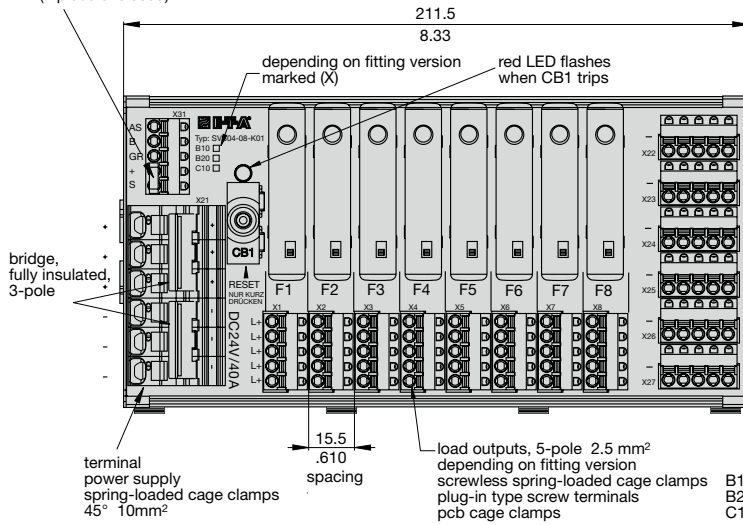

6

This is a metric design and millimeter dimensions take precedence (mm / inch)

Application example for jumper to replace

The signalling pathway of the group signalisation is as follows:

- feed-in of +DC 24 V potential in X31 (»+« terminal) via in-built overcurrent protection CB1
- via all signal contacts of the fitted circuit breakers type ESS20-003
- back to signal output of group signalisation X31 (»AS«)

In operating condition (i.e. all circuit breakers plugged in and functional) the signalling pathway X31 from »+« to »AS« is closed.

If the distribution rail is not completely fitted with ESS20-003, the open pathway »+« to »AS« may be closed by means of a jumper type SB-S11-P1-01-1-1A

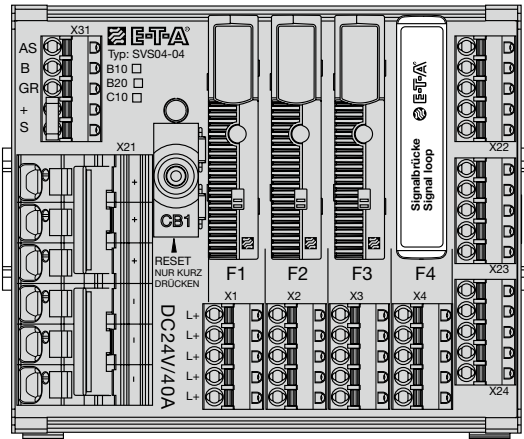

Accessories

Jumper SB-S11-P1-01-1-1A

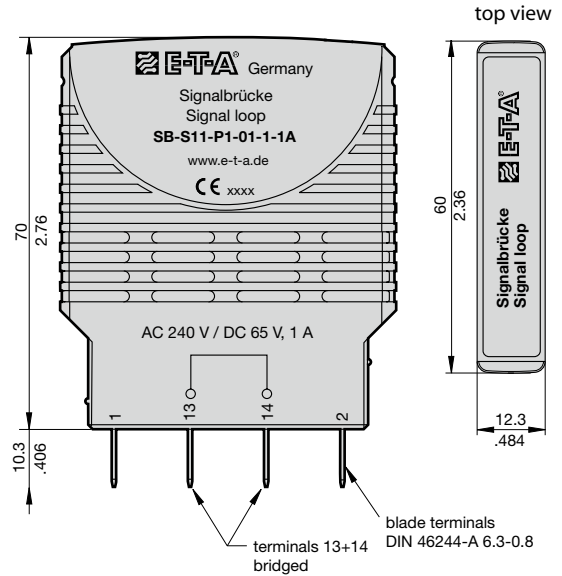

Insulated wire bridge Y 303 881 08

1 piece of the insulated wire bridge are supplied with the power distribution system. The insulated wire bridges may be used for:

- terminal X31: internal DC 24 V feed for group signalisation wire bridge from (+) to (S) signal path protected by CB1
- terminal X31: internal DC 24 V feed for two-group signalisation wire bridge from (+) to (GR) signal path protected by CB1

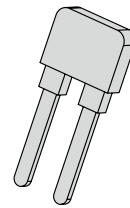

Application example for insulated wire bridge

Terminal X31 (group signalisation)
wire bridge from (+) to (S)
internal +DC24V feed for signalisation
Thus plus potential of terminal X21+ is connected to (S)

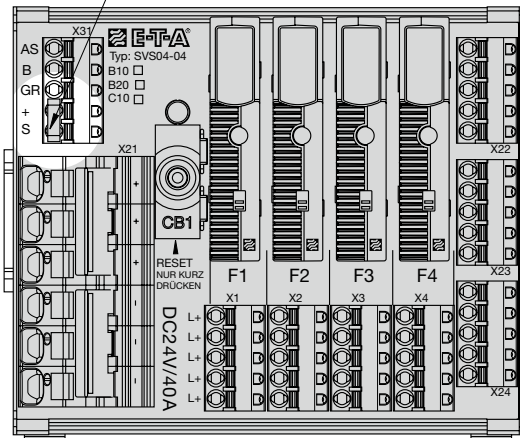

This is a metric design and millimeter dimensions take precedence (mm / inch)

All dimensions without tolerances are for reference only. In the interest of improved design, performance and cost effectiveness the right to make changes in these specifications without notice is reserved. Product markings may not be exactly as the ordering codes. Errors and omissions excepted.



Компания «ЭлектроПласт» предлагает заключение долгосрочных отношений при поставках импортных электронных компонентов на взаимовыгодных условиях!

Наши преимущества:

- Оперативные поставки широкого спектра электронных компонентов отечественного и импортного производства напрямую от производителей и с крупнейших мировых складов;
- Поставка более 17-ти миллионов наименований электронных компонентов;
- Поставка сложных, дефицитных, либо снятых с производства позиций;
- Оперативные сроки поставки под заказ (от 5 рабочих дней);
- Экспресс доставка в любую точку России;
- Техническая поддержка проекта, помощь в подборе аналогов, поставка прототипов;
- Система менеджмента качества сертифицирована по Международному стандарту ISO 9001;
- Лицензия ФСБ на осуществление работ с использованием сведений, составляющих государственную тайну;
- Поставка специализированных компонентов (Xilinx, Altera, Analog Devices, Intersil, Interpoint, Microsemi, Aeroflex, Peregrine, Syfer, Eurofarad, Texas Instrument, Miteq, Cobham, E2V, MA-COM, Hittite, Mini-Circuits, General Dynamics и др.);

Помимо этого, одним из направлений компании «ЭлектроПласт» является направление «Источники питания». Мы предлагаем Вам помощь Конструкторского отдела:

- Подбор оптимального решения, техническое обоснование при выборе компонента;
- Подбор аналогов;
- Консультации по применению компонента;
- Поставка образцов и прототипов;
- Техническая поддержка проекта;
- Защита от снятия компонента с производства.



Как с нами связаться

Телефон: 8 (812) 309 58 32 (многоканальный)

Факс: 8 (812) 320-02-42

Электронная почта: org@eplast1.ru

Адрес: 198099, г. Санкт-Петербург, ул. Калинина, дом 2, корпус 4, литера А.