

PRODUCT NUMBER
SEE SHEET 3

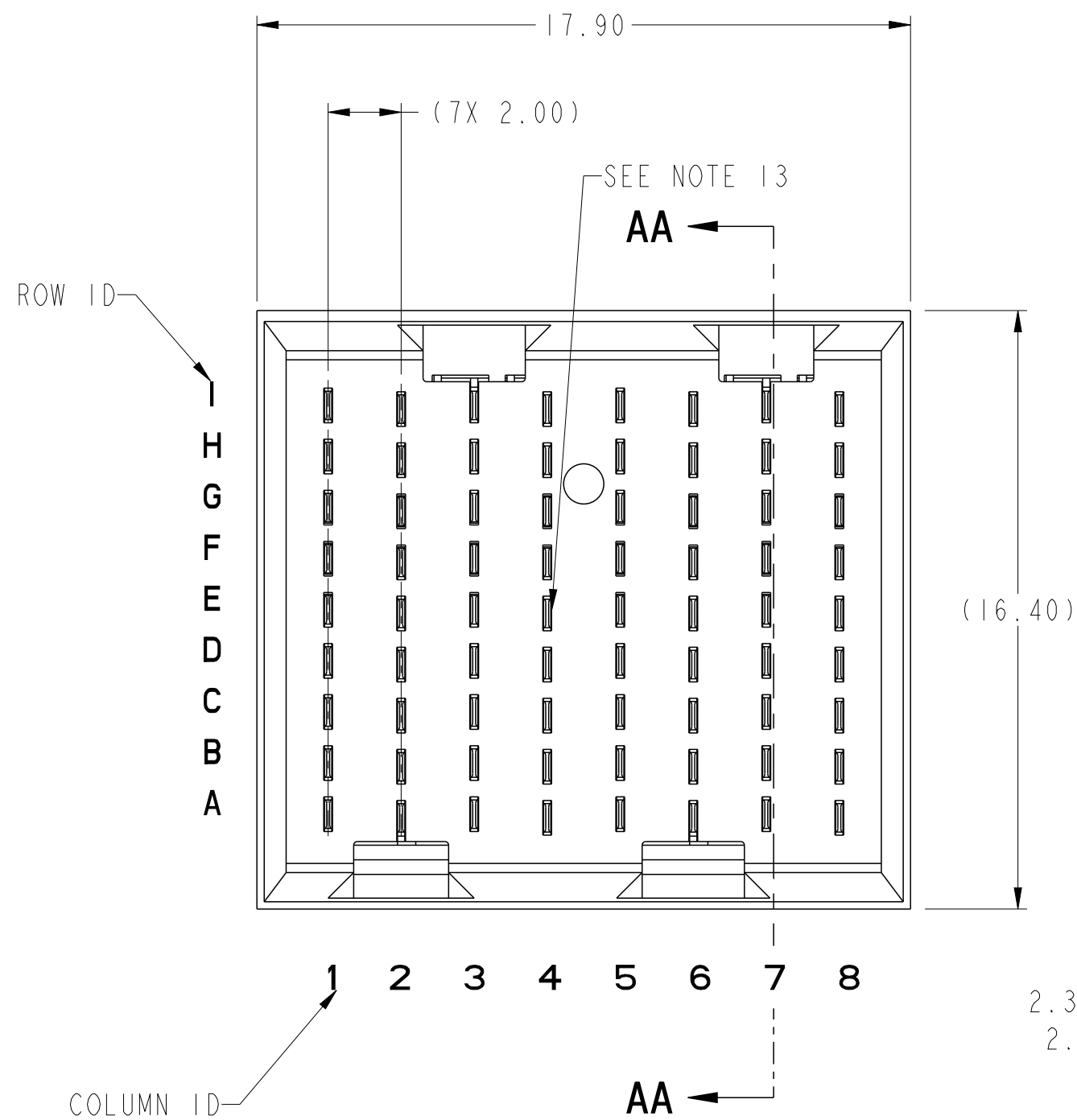

TOP SURFACE OF MOTHER BOARD

TOP SURFACE OF DAUGHTER CARD

2.35 ϕ OF EVEN COLUMNS
2.25 ϕ OF ODD COLUMNS

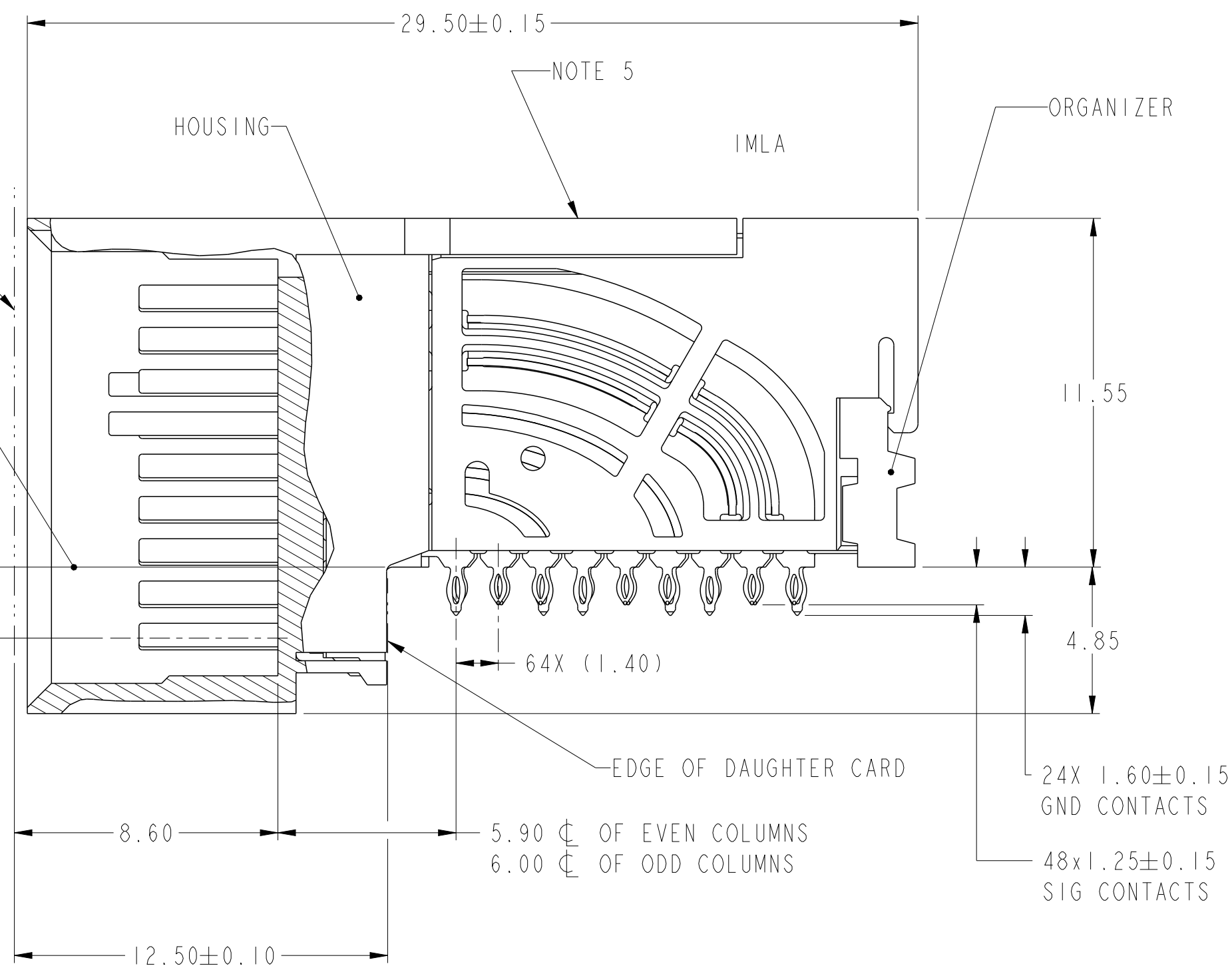

SECTION AA-AA

spec ref	---	dr	Lin-Soe Ngwe	2013/03/20	projection	MM	size	A2	scale	6:1												
tolerance std	ASME Y14.5M	eng	Art Lin	2016/11/15			ecn no	ELX-DG-25255-1	rel level	Released												
TOLERANCES UNLESS OTHERWISE SPECIFIED		chr	Heaven Cen	2016/11/17			product family	AirMax VSE														
surface	<table border="1"> <tr> <td>linear</td> <td>0.X</td> <td>±.3</td> </tr> <tr> <td></td> <td>0.XX</td> <td>±.15</td> </tr> <tr> <td></td> <td>0.XXX</td> <td>±.050</td> </tr> <tr> <td>angular</td> <td>0°</td> <td>±2°</td> </tr> </table>	linear	0.X	±.3				0.XX			±.15		0.XXX	±.050	angular	0°	±2°	appr	Pai-Ming Zheng	2016/11/18	title	AirMax VS2 R.A. HEADER
linear	0.X	±.3																				
	0.XX	±.15																				
	0.XXX	±.050																				
angular	0°	±2°																				
		www.fci.com		cat. no.	Product - Customer Drw		sheet 1 of 3															

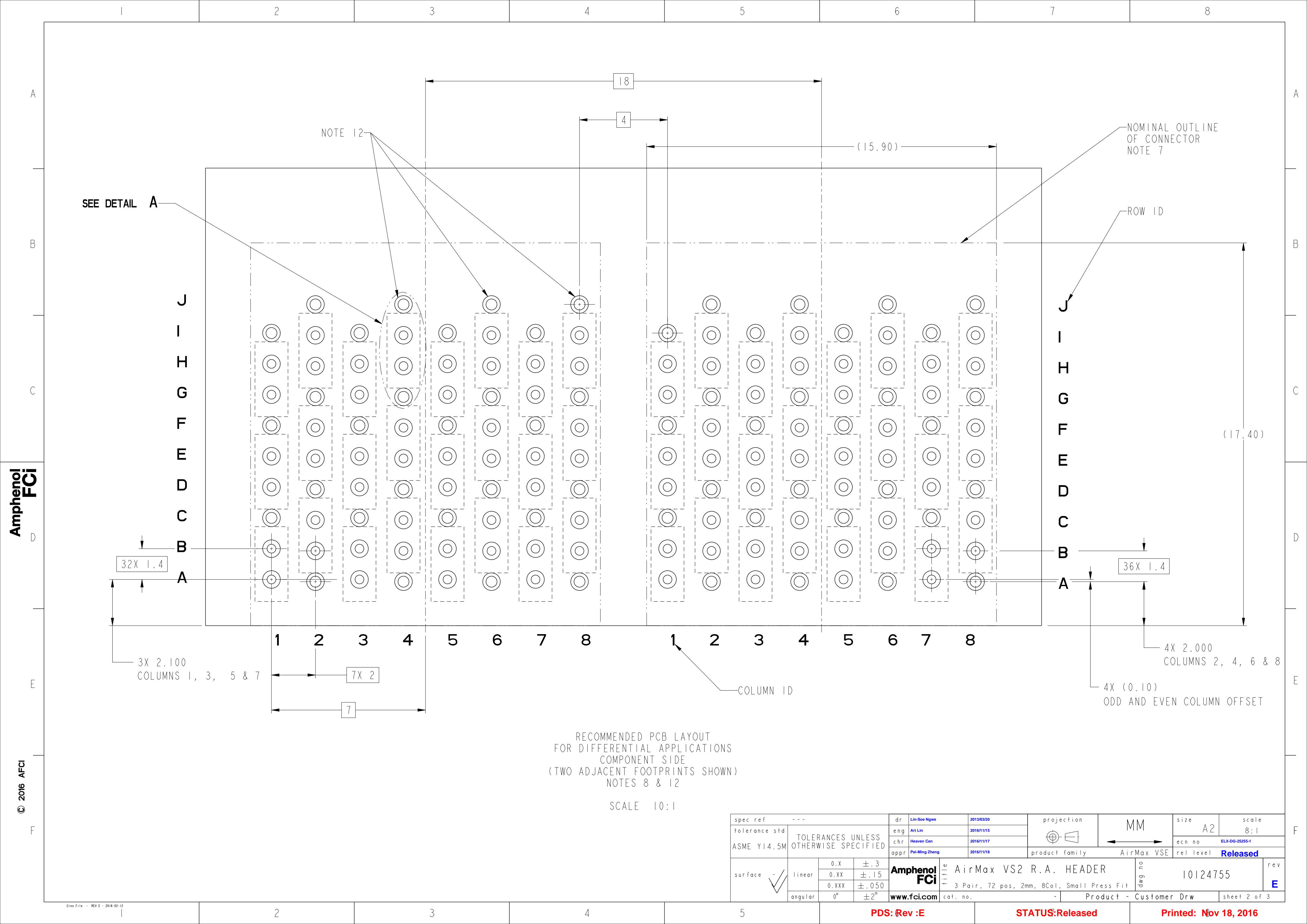

Amphenol
FCi

© 2016 APCI

RECOMMENDED PCB LAYOUT
FOR DIFFERENTIAL APPLICATIONS
COMPONENT SIDE
(TWO ADJACENT FOOTPRINTS SHOWN)
NOTES 8 & 12

SCALE 10:1

spec ref	---	dr	Lin-Soc Ngwe	2013/03/20	projection	MM	size	A2	scale	8:1												
tolerance std	ASME Y14.5M	eng	Art Lin	2016/11/15			ecn no	ELX-DG-25255-1	rel level	Released												
TOLERANCES UNLESS OTHERWISE SPECIFIED		chr	Heaven Cen	2016/11/17			product family	AirMax VSE														
surface	<table border="1"> <tr> <td>linear</td> <td>0.X</td> <td>±.3</td> </tr> <tr> <td></td> <td>0.XX</td> <td>±.15</td> </tr> <tr> <td></td> <td>0.XXX</td> <td>±.050</td> </tr> <tr> <td>angular</td> <td>0°</td> <td>±2°</td> </tr> </table>	linear	0.X	±.3				0.XX		±.15		0.XXX	±.050	angular	0°	±2°	appr	Pai-Ming Zheng	2016/11/18	title	AirMax VS2 R.A. HEADER	dwg no
linear	0.X	±.3																				
	0.XX	±.15																				
	0.XXX	±.050																				
angular	0°	±2°																				
		www.fci.com	cat. no.	-	Product - Customer Drw		sheet 2 of 3															

PDS: Rev :E

STATUS:Released

Printed: Nov 18, 2016

PRODUCT NUMBER	PRESS-FIT TAIL PLATING TYPE	SHORT DETECT CONTACT	REMARK
10124755-101	TIN/LEAD ALLOY OVER NICKEL	NO	ONE SIDE PLATING (CUSTOMER SPECIAL)
10124755-101LF	TIN OVER NICKEL (LEAD FREE)		
10124755-111	TIN/LEAD ALLOY OVER NICKEL	YES (SEE NOTE 13)	
10124755-111LF	TIN OVER NICKEL (LEAD FREE)		
10124755-102	TIN/LEAD ALLOY OVER NICKEL	NO	TWO SIDE PLATING
10124755-102LF	TIN OVER NICKEL (LEAD FREE)		
10124755-112	TIN/LEAD ALLOY OVER NICKEL	YES (SEE NOTE 13)	
10124755-112LF	TIN OVER NICKEL (LEAD FREE)		

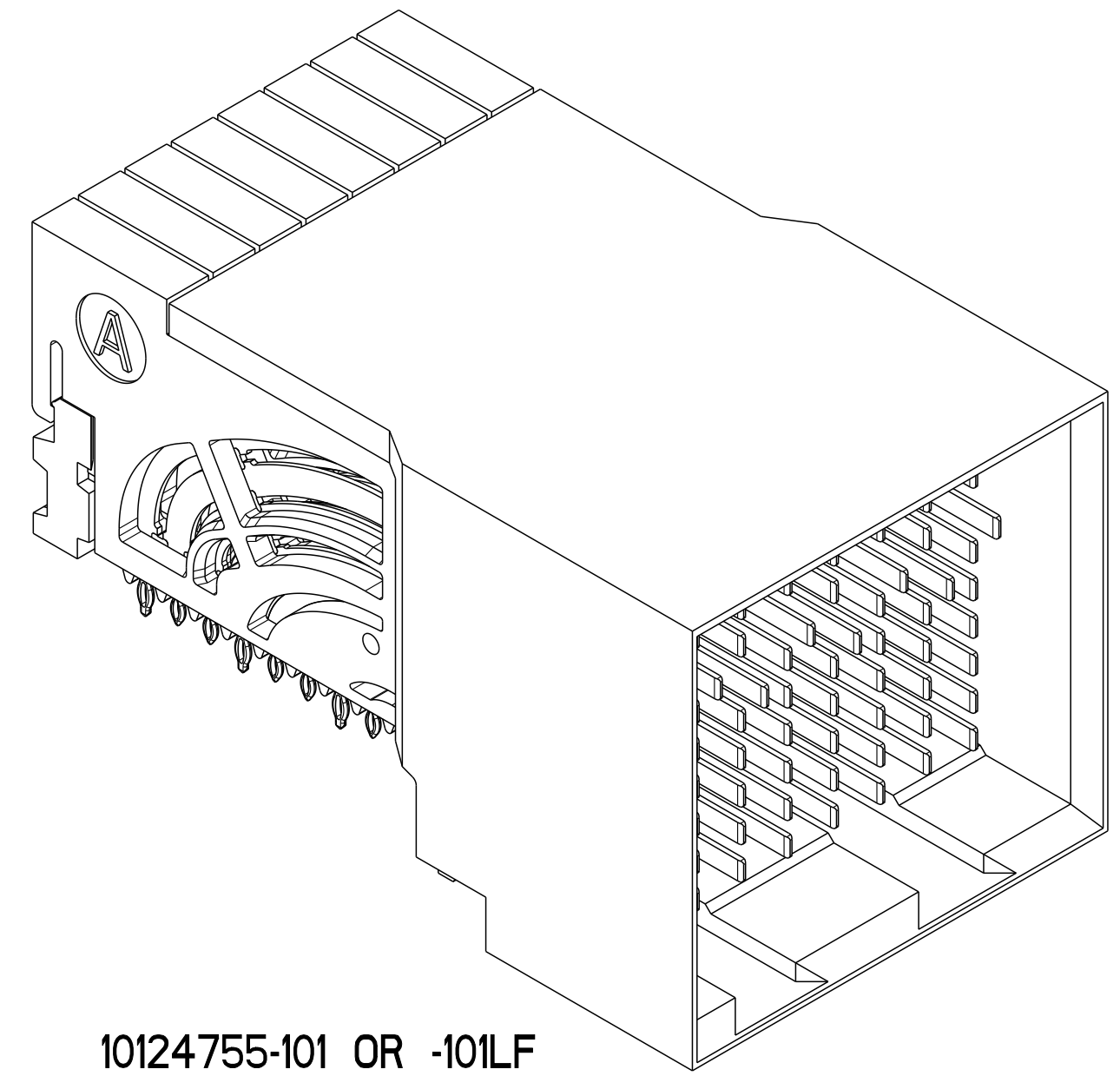

10124755-101 OR -101LF

- 1 - CONNECTOR MATERIALS:
HOUSING: HIGH TEMP THERMOPLASTIC, NATURAL, UL94-V0
IMLA PLASTIC: HIGH TEMP THERMOPLASTIC, BLACK, UL94-V0
CONTACT: COPPER ALLOY
ORGANIZER: HIGH TEMP THERMOPLASTIC, NATURAL, UL94-V0
- 2 - CONTACT PLATING:
SEPARABLE INTERFACE:
GXT PLUS PLATING, QUALIFIED TO MEET THE REQUIREMENTS OF FCI PRODUCT SPECIFICATION GS-12-0956 INCLUDING TELCORDIA GR-1217-CORE (NOVEMBER 1995) CENTRAL OFFICE TEST SEQUENCE

PRESS-FIT TAILS: SEE TABLE
- 3 - PRODUCT SPECIFICATION: GS-12-0956
- 4 - APPLICATION SPECIFICATION: GS-20-0305
- 5 - PRODUCT MARKING, (PROTOTYPE, PART NUMBER & LOT CODE), ON THIS SURFACE.
- 6 - POSITIONS "F" OF ODD NUMBERED COLUMNS AND POSITIONS "G" OF EVEN NUMBERED COLUMNS CORRESPOND TO EARLY MATE HEADER PINS.
- 7 - CONNECTOR OUTLINE MAY BE SCREEN PRINTED ONTO CUSTOMER PCB TO BE USED AS A GUIDE FOR CONNECTOR PLACEMENT.
- 8 - REFER TO CUSTOMER DRAWING 10104444 FOR INFORMATION ON PCB HOLE DIAMETERS AND PLATING OPTIONS
- 9 - LEAD FREE PRODUCT MEETS THE EUROPEAN UNION DIRECTIVES & OTHER COUNTRY REGULATIONS AS DESCRIBED IN GS-22-008
- 10 - PACKAGING MEETS GS-14-920 LEAD FREE LABELING SPECIFICATION.
- 11 - GROUND CONTACTS (C, F, & I IN ODD COLUMNS AND A, D, & G IN EVEN COLUMNS) REQUIRE (Ø0.50) FINISHED HOLES. SIGNAL LOCATIONS REQUIRE (Ø0.40) FINISHED HOLES
- 12 - THESE OUTER VIAS (J) ARE OPTIONAL. WHILE NO CONNECTOR EONS ARE PRESSED INTO THESE HOLES WE RECOMMEND (Ø0.500) FINISHED HOLES AT THESE LOCATIONS TO PROVIDE GROUND SYMMETRY THROUGH THE PCB.
- 13- MATING PIN E4 HAS 0.5mm LESS NOMINAL WIPE THAN THE SHORTEST PIN.
- 14- A \triangle SYMBOL WILL BE NEXT TO ANY DIMENSION, VIEW, OR NOTE, WHICH HAS BEEN MODIFIED WITH THE CURRENT DRAWING REVISION

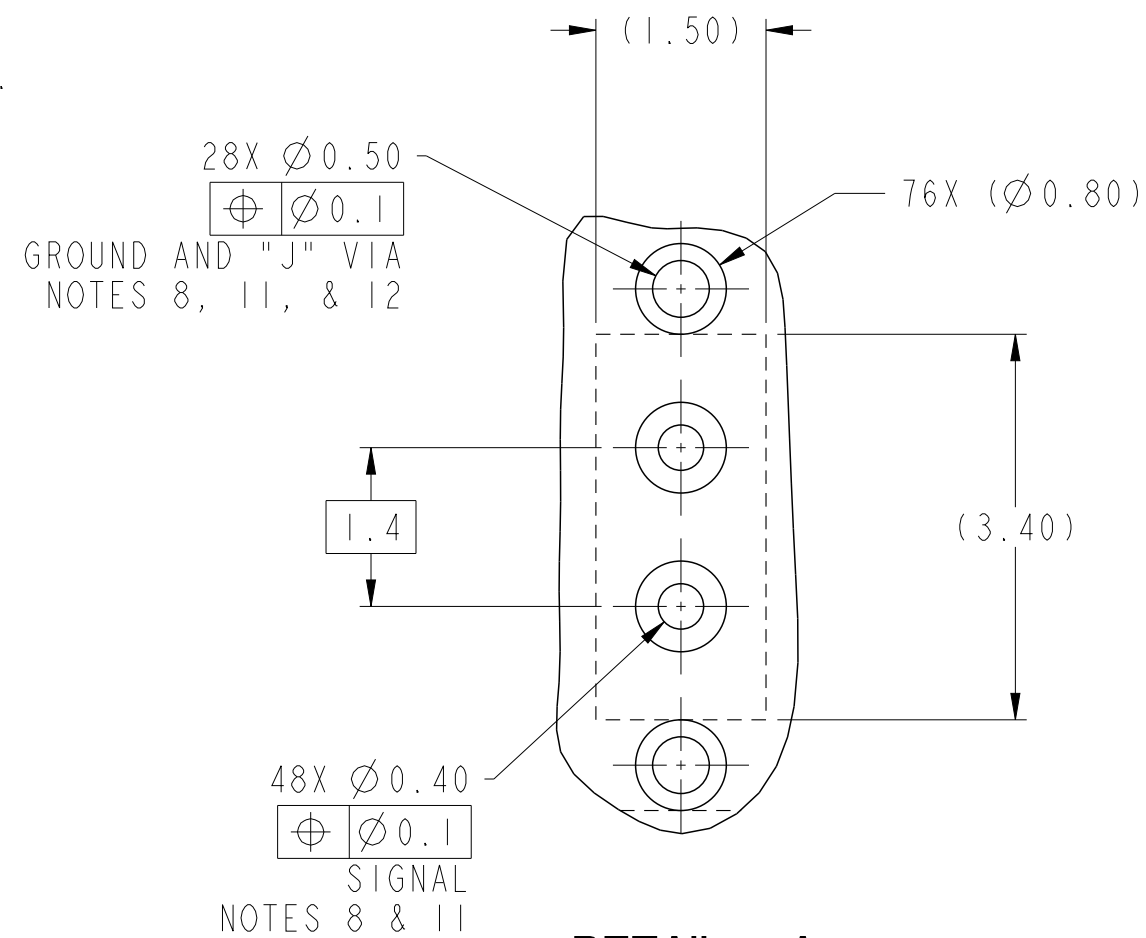

DETAIL A SCALE 15:1

spec ref	---	dr	Lin-Soe Ngwe	2013/03/20	projection	MM	size	A2	scale	5:1												
tolerance std	ASME Y14.5M	eng	Art Lin	2016/11/15			ecn no	ELX-DG-25255-1	rel level	Released												
TOLERANCES UNLESS OTHERWISE SPECIFIED		chr	Heaven Cen	2016/11/17			product family	AirMax VSE														
surface	<table border="1"> <tr> <td>linear</td> <td>0.X</td> <td>±.3</td> </tr> <tr> <td></td> <td>0.XX</td> <td>±.15</td> </tr> <tr> <td></td> <td>0.XXX</td> <td>±.050</td> </tr> <tr> <td>angular</td> <td>0°</td> <td>±2°</td> </tr> </table>	linear	0.X	±.3				0.XX		±.15		0.XXX	±.050	angular	0°	±2°	appr	Pei-Ming Zheng	2016/11/18	title	AirMax VS2 R.A. HEADER	dwg no
linear	0.X	±.3																				
	0.XX	±.15																				
	0.XXX	±.050																				
angular	0°	±2°																				
		www.fci.com		cat. no.	Product - Customer Drw		sheet 3 of 3															

Amphenol FCI

© 2016 AFCI



Компания «ЭлектроПласт» предлагает заключение долгосрочных отношений при поставках импортных электронных компонентов на взаимовыгодных условиях!

Наши преимущества:

- Оперативные поставки широкого спектра электронных компонентов отечественного и импортного производства напрямую от производителей и с крупнейших мировых складов;
- Поставка более 17-ти миллионов наименований электронных компонентов;
- Поставка сложных, дефицитных, либо снятых с производства позиций;
- Оперативные сроки поставки под заказ (от 5 рабочих дней);
- Экспресс доставка в любую точку России;
- Техническая поддержка проекта, помощь в подборе аналогов, поставка прототипов;
- Система менеджмента качества сертифицирована по Международному стандарту ISO 9001;
- Лицензия ФСБ на осуществление работ с использованием сведений, составляющих государственную тайну;
- Поставка специализированных компонентов (Xilinx, Altera, Analog Devices, Intersil, Interpoint, Microsemi, Aeroflex, Peregrine, Syfer, Eurofarad, Texas Instrument, Miteq, Cobham, E2V, MA-COM, Hittite, Mini-Circuits, General Dynamics и др.);

Помимо этого, одним из направлений компании «ЭлектроПласт» является направление «Источники питания». Мы предлагаем Вам помощь Конструкторского отдела:

- Подбор оптимального решения, техническое обоснование при выборе компонента;
- Подбор аналогов;
- Консультации по применению компонента;
- Поставка образцов и прототипов;
- Техническая поддержка проекта;
- Защита от снятия компонента с производства.



Как с нами связаться

Телефон: 8 (812) 309 58 32 (многоканальный)

Факс: 8 (812) 320-02-42

Электронная почта: org@eplast1.ru

Адрес: 198099, г. Санкт-Петербург, ул. Калинина, дом 2, корпус 4, литера А.