

3mm LED CBI® Circuit Board Indicator DIN 41494 Bi-Level

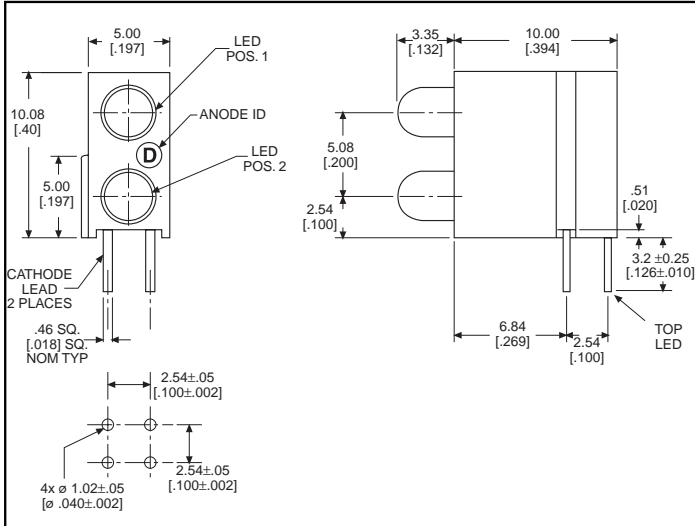

Standard Polarity shown in drawing: Cathode left

Features

- Designed to accommodate DIN 41494
- Multiple CBIs form horizontal LED arrays on 5.0mm (0.197") center-lines.
- High Contrast, UL 94 V-0 rated, black housing
- Oxygen index: 32%
- Polymer content: PBT, 0.542 g
- Housing stand-offs facilitate PCB cleaning
- Solderability per MIL-STD-202F, method 208F
- LEDs are safe for direct viewing per IEC 825-1, EN-60825-1

Tolerance note: As noted, otherwise:

- LED Protrusion: ± 0.04 mm [± 0.016]
- CBI Housing: ± 0.02 mm [± 0.008]

Custom Combinations

- Contact factory for information on custom bi-level arrays and color combinations.

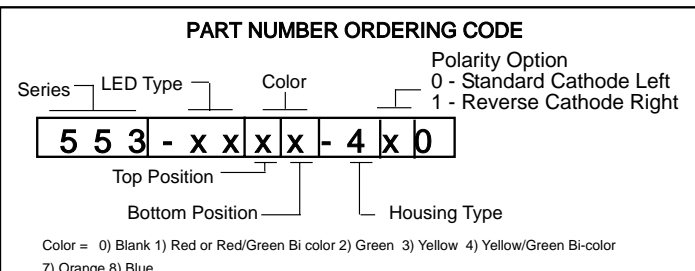

PART NO.

HIGH EFFICIENCY - LED TYPE 01

- 553-0111-400
- 553-0122-400
- 553-0133-400
- 553-0188-400

COLOR*

- Red
- Green
- Yellow
- Blue³



LOW CURRENT - LED TYPE 02

- 553-0211-400
- 553-0222-400
- 553-0233-400

- Red
- Green
- Yellow

RESISTOR 5 VOLTS - LED TYPE 03

- 553-0311-400
- 553-0322-400
- 553-0333-400

- Red
- Green
- Yellow

BI-COLOR - LED TYPE 07

- 553-0711-400
- 553-0744-400

- Red/Green
- Yellow/Green

NON-DIFFUSED - LED TYPE 22

- 553-2211-400
- 553-2222-400
- 553-2233-400

- Red
- Green
- Yellow

* Top-Bottom LED

REVERSE POLARITY OPTION AVAILABLE

See Part Number Ordering Code below.



ATTENTION
OBSERVE PRECAUTIONS
FOR HANDLING
ELECTROSTATIC
SENSITIVE
DEVICES

553-xxxx-400

(DIN 41494 compatible)

Typical Operating Characteristics ($T_A=25^{\circ}\text{C}$)

See LED data sheet for additional information
See page 4-70 and 4-71 for Reference Only LED Drive Circuit Examples. See page 4-72 for Pin Out

HIGH EFFICIENCY

Part Number	Color	Peak Wavelength nm	I_V mcd	V_F Volts	Test Current (mA)	Viewing Angle $2\Theta_{\%}$	LED Data sheet	Page #
553-0111-400	Red	635	10	2*	10	60°	521-9216	4-58
553-0122-400	Green	565	12.6	2.1*	10	60°	521-9210	4-58
553-0133-400	Yellow	585	10	2.1*	10	60°	521-9211	4-58
553-0177-400	Orange	600	7	2.2	10	60°	521-9498	4-58
553-0188-400	Blue	428	12	3.5	10	70°	521-9831	4-57

* $I_F=20\text{mA}$

LOW CURRENT

Part Number	Color	Peak Wavelength nm	I_V mcd	V_F Volts	Test Current (mA)	Viewing Angle $2\Theta_{\%}$	LED Data sheet	Page #
553-0211-400	Red	635	1.6	1.7	2	60°	521-9324	4-60
553-0222-400	Green	565	1.6	1.9	2	60°	521-9326	4-60
553-0233-400	Yellow	585	1.6	1.8	2	60°	521-9325	4-60

INTEGRAL RESISTOR, 5 VOLTS

Part Number	Color	Peak Wavelength nm	I_V mcd	Test Voltage	Forward Current (mA)	Viewing Angle $2\Theta_{\%}$	LED Data sheet	Page #
553-0311-400	Red	635	29	5	10	60°	521-9215	4-59
553-0322-400	Green	565	19	5	10	60°	521-9323	4-59
553-0333-400	Yellow	585	12.6	5	10	60°	521-9322	4-59

BI-COLOR

Part Number	Color	Peak Wavelength nm	I_V mcd	V_F Volts	Test Current (mA)	Viewing Angle $2\Theta_{\%}$	LED Data sheet	Page #
553-0711-400	Red/Green	635/565	4.7/10	2/2.1	10	50°	521-9459	4-63
553-0744-400	Yellow/Green	585/565	4.3/6.3	2.1*/2.1*	10	80°	521-9478	4-62

* $I_F = 20\text{mA}$

NON-DIFFUSED

Part Number	Color	Peak Wavelength nm	I_V mcd	V_F Volts*	Test Current (mA)	Viewing Angle $2\Theta_{\%}$	LED Data sheet	Page #
553-2211-400	Red	635	29	2	10	45°	521-9432	4-61
553-2222-400	Green	565	50	2.1	10	45°	521-9430	4-61
553-2233-200	Yellow	585	20	2.1	10	45°	521-9431	4-61

* $I_F = 20\text{mA}$

CBI ARRAYS .200 PITCH

Dialight offers its Multiarray to reduce insertions and to assure indicator alignment. Multiarrays mount indicators on .200 centers. These assemblies are available in arrays of 2 to 6. See pages 4-41 and 4-42 for information. Call factory for information on .185 pitched arrays.





3mm Discrete LED Tinted, Diffused

Dialight

521-9831



PART NO. 521-9831
COLOR Blue³

MOUNTING CLIP: 515-0006
located on page 4-65



ATTENTION
OBSERVE PRECAUTIONS
FOR HANDLING
ELECTROSTATIC
SENSITIVE
DEVICES

4

ABSOLUTE MAXIMUM RATINGS (T_A=25°C)

Blue
-9831

Power Dissipation (mW)	100
Forward Current (mA)	20
Derating (mA/°C) From 55°C	.44
Operating Temperature (°C)	-40/+100
Storage Temperature (°C)	-40/+100
Soldering Temperature	260°C, 5 seconds, 1.6 mm from case

Solder Adherence per MIL-STD-202E, Method 208C

OPERATING CHARACTERISTICS (T_A=25°C)

Blue
-9831

Luminous Intensity (mcd)	Min.	6.3
I _F =10mA	Typical	12
Peak Wavelength (nm)	Typical	428
λ Peak		
Viewing Angle (2Θ _{1/2})	Typical	70°
Forward Voltage (V)	Typical	3.5
I _F =10mA	Max.	4.2
Reverse Voltage (V) IR=10μA	Min.	3

Θ_{1/2} is the off axis angle at which the luminous intensity is half the axial luminous intensity

3mm Discrete LED
High Efficiency
Diffused



521-9210, -9211, -9216, -9498, -9636

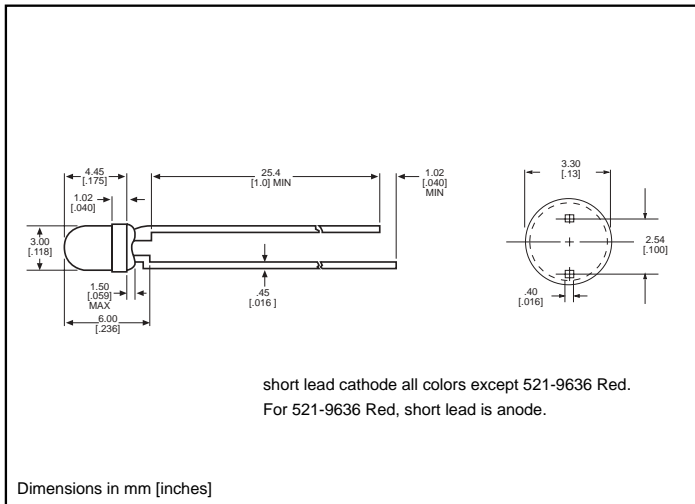

PART NO. COLOR

- 521-9210 Green
- 521-9211 Yellow
- 521-9216 Red
- 521-9498 Orange
- 521-9636 Red



MOUNTING CLIP: 515-0006
 located on page 4-65

ABSOLUTE MAXIMUM RATINGS (T _A =25°C)	Green -9210	Yellow -9211	Red -9216	Orange -9498	Red -9636
Power Dissipation (mW)	100	60	100	135	100
Forward Current (mA)	30	20	30	25	40
Derating (mA/°C) From 50°C 1 from 25°C	.4	.25	.4	.5	.5 ¹
Operating Temperature (°C)	-55/+100	-55/+100	-55/+100	-55/+100	-55/+100
Storage Temperature (°C)	-55/+100	-55/+100	-55/+100	-55/+100	-55/+100
Soldering Temperature	260°C, 5 seconds, 1.6 mm from body				

Solder Adherence per MIL-STD-202E, Method 208C

OPERATING CHARACTERISTICS (T _A =25°C)		Green -9210	Yellow -9211	Red -9216	Orange -9498	Red -9636
Luminous Intensity (mcd)	Min.	4.7	7.4	7.4	3.4	8.7 ¹
	I _F =10mA 1 I _F =20mA	Typical	12.6	10	10	7
Peak Wavelength (nm)	Typical	565	585	635	600	660
Viewing Angle (2θ °)	Typical	60°	60°	60°	60°	60°
Forward Voltage (V)	Typical	2.1 ¹	2.1 ¹	2 ¹	2.2	1.8 ¹
	I _F =10mA 1 I _F =20mA	Max.	2.8 ¹	2.8 ¹	2.8 ¹	3
Reverse Voltage (V), I _R =100µA	Max.	5	5	5	5	4

¹ is the off axis angle at which the luminous intensity is half the axial luminous intensity

**3mm Discrete LED
Integral Resistor, 5V
Diffused**

Dialight

521-9215, -9322, -9323



PART NO.	COLOR
521-9215	Red
521-9322	Yellow
521-9323	Green

MOUNTING CLIP: 515-0006
located on page 4-65

ABSOLUTE MAXIMUM RATINGS ($T_A=25^\circ\text{C}$)	Red	Yellow	Green
	-9215	-9322	-9323
Forward Voltage (V)	7.5	7.5	7.5
Derating ($V/^\circ\text{C}$) From 50°C	.086	.086	.071
Operating Temperature ($^\circ\text{C}$)	-40/+85	-40/+85	-20/+85
Storage Temperature ($^\circ\text{C}$)	-55/+100	-55/+100	-55/+100
Soldering Temperature	260 $^\circ\text{C}$, 5 seconds, 1.6 mm from case		

Solder Adherence per MIL-STD-202E, Method 208C

OPERATING CHARACTERISTICS ($T_A=25^\circ\text{C}$)		Red	Yellow	Green
		-9215	-9322	-9323
Luminous Intensity (mcd)	Min.	8.7	3.7	5.6
	Typical	29	12.6	19
Peak Wavelength (nm)	Typical	635	585	565
Viewing Angle ($2\theta_{1/2}$)	Typical	60 $^\circ$	60 $^\circ$	60 $^\circ$
Forward Current (mA)	Typical	10	10	10
	Max.	20	20	20
Reverse Voltage (V), $I_R=100\mu\text{A}$	Min.	5	5	5

$\theta_{1/2}$ is the off axis angle at which the luminous intensity is half the axial luminous intensity

4

3mm Discrete LED
Low Current
Diffused

Dialight

521-9324, -9325, -9326



PART NO. **COLOR**

521-9324	Red
521-9325	Yellow
521-9326	Green

MOUNTING CLIP: 515-0006
 located on page 4-65

ABSOLUTE MAXIMUM RATINGS ($T_A=25^\circ\text{C}$)

	Red -9324	Yellow -9325	Green -9326
Power Dissipation (mW)	20	20	20
Forward Current (mA)	7	7	7
Derating (mA/°C) From 90°C	.7	.7	.7
Peak Current (mA) Pulse width = 10 μs	500	500	500
Operating Temperature (°C)	-55/+100	-55/+100	-55/+100
Storage Temperature (°C)	-55/+100	-55/+100	-55/+100
Soldering Temperature	260°C, 5 seconds, 1.6 mm from case		

Solder Adherence per MIL-STD-202E, Method 208C

OPERATING CHARACTERISTICS ($T_A=25^\circ\text{C}$)

		Red -9324	Yellow -9325	Green -9326
Luminous Intensity (mcd) $I_F=2\text{mA}$	Min.	1	1	1
	Typical	1.6	1.6	1.6
Peak Wavelength (nm) λ_{Peak}	Typical	635	585	565
Viewing Angle (2θ)	Typical	60°	60°	60°
Forward Voltage (V) $I_F=2\text{mA}$	Typical	1.7	1.8	1.9
	Max.	2.2	2.7	2.2
Reverse Voltage (V), $I_R=50\mu\text{A}$	Min.	5	5	5

θ is the off axis angle at which the luminous intensity is half the axial luminous intensity

3mm Discrete LED
High Efficiency
Tinted, Non-Diffused

Dialight

521-9430, -9431, -9432



PART NO.

COLOR

521-9430
 521-9431
 521-9432

Green
 Yellow
 Red

MOUNTING CLIP: 515-0006
 located on page 4-65

ABSOLUTE MAXIMUM RATINGS ($T_A=25^\circ\text{C}$)

	Green -9430	Yellow -9431	Red -9432
Power Dissipation (mW)	100	60	100
Forward Current (mA)	30	20	30
Derating (mA/°C) From 50°C	.4	.25	.4
Peak Current (mA) Pulse width = 100µs	120	80	120
Operating Temperature (°C)	-55/+100	-55/+100	-55/+100
Storage Temperature (°C)	-55/+100	-55/+100	-55/+100
Soldering Temperature	260°C, 5 seconds, 1.6 mm from case		

Solder Adherence per MIL-STD-202E, Method 208C

OPERATING CHARACTERISTICS ($T_A=25^\circ\text{C}$)

		Green -9430	Yellow -9431	Red -9432
Luminous Intensity (mcd) $I_F=10\text{mA}$	Min.	32	10	8.7
	Typical	50	20	29
Peak Wavelength (nm) λ Peak	Typical	565	585	635
Viewing Angle ($2\theta_{1/2}$)	Typical	45°	45°	45°
Forward Voltage (V) $I_F=20\text{mA}$	Typical	2.1	2.1	2
	Max.	2.8	2.8	2.8

$\theta_{1/2}$ is the off axis angle at which the luminous intensity is half the axial luminous intensity

4

3mm Discrete LED
Bi-Color
Non-Tinted, Diffused



521-9478, -9628, -9768

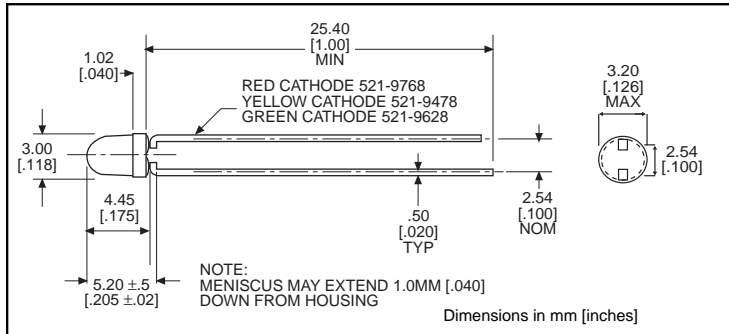

<u>PART NO.</u>	<u>COLOR</u>
521-9478	Yellow/Green
521-9628	Red/Green
521-9768	Red/Yellow

MOUNTING CLIP: 515-0006
 located on page 4-65

ABSOLUTE MAXIMUM RATINGS ($T_A=25^\circ\text{C}$)	Yellow/Green -9478	Red/Green -9628	Red/Yellow -9768
Power Dissipation (mW)	60/100	140/100	100/60
Forward Current (mA)	20/30	40/30	30/20
Derating (mA/°C) From 25°C From 50°C	.25 ¹ /.40 ¹	.5/.4	.4 ¹ /.25 ¹
Peak Current (mA) Pulse width = 10µs	80/120	200/120	120/80
Operating Temperature (°C)	-55/+100	-55/+100	-55/+100
Storage Temperature (°C)	-55/+100	-55/+100	-55/+100
Soldering Temperature	260°C, 5 seconds, 1.66 mm from case		

Solder Adherence per MIL-STD-202E, Method 208C

OPERATING CHARACTERISTICS ($T_A=25^\circ\text{C}$)		Yellow/Green -9478	Red/Green -9628	Red/Yellow -9768
Luminous Intensity (mcd)	Min.	2.5/2.5	3.7*/1.1*	1.7*/1.7*
	Typical	4.3/6.3	12.6*/3.7*	5.6*/5.6*
Peak Wavelength (nm)	Typical	585/565	660/565	630/585
λ Peak				
Viewing Angle (2θ °)	Typical	80°	200°	80°
Forward Voltage (V)	Typical	2.1/2.1	1.8/2.1	2/2.1
	Max.	2.8/2.8	2.4/2.8	2.8/2.8
Reverse Voltage (V) $I_R=100\text{ua}$	Min.	5	5	5

θ ° is the off axis angle at which the luminous intensity is half the axial luminous intensity

**3mm Discrete LED
Bi-Color
Non-Tinted, Diffused**

Dialight

521-9459

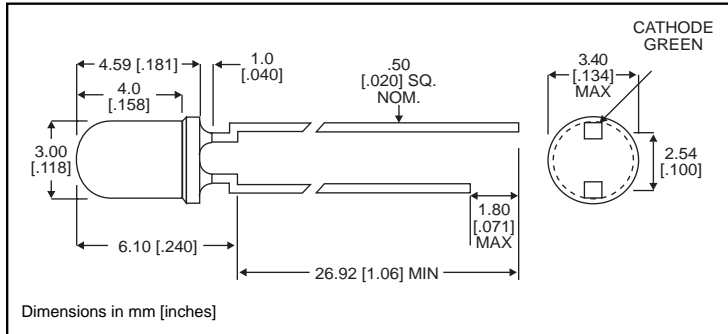

PART NO. 521-9459
COLOR Red/Green

MOUNTING CLIP: 515-0006
located on page 4-65

4

ABSOLUTE MAXIMUM RATINGS ($T_A=25^\circ\text{C}$)

Red/Green
-9459

Power Dissipation (mW)	140
Forward Current (mA)	45
Derating (mA/°C) From 25°C	.6
Peak Current (mA)	1000
Pulse width = 10µs	
Operating Temperature (°C)	-55/+100
Storage Temperature (°C)	-55/+100
Soldering Temperature	260°C, 5 seconds, 1.6 mm from case

Solder Adherence per MIL-STD-202E, Method 208C

OPERATING CHARACTERISTICS ($T_A=25^\circ\text{C}$)

Red/Green
-9459

Luminous Intensity (mcd)	Min.	2.5/3.7
$I_F=10\text{mA}$	Typical	4.7/10
Peak Wavelength (nm)	Typical	635/565
λ Peak		
Viewing Angle ($2\theta_{1/2}$)	Typical	50°
Forward Voltage (V)	Typical	2/2.1
$I_F=10\text{mA}$	Max.	2.8/2.8

$\theta_{1/2}$ is the off axis angle at which the luminous intensity is half the axial luminous intensity



Компания «ЭлектроПласт» предлагает заключение долгосрочных отношений при поставках импортных электронных компонентов на взаимовыгодных условиях!

Наши преимущества:

- Оперативные поставки широкого спектра электронных компонентов отечественного и импортного производства напрямую от производителей и с крупнейших мировых складов;
- Поставка более 17-ти миллионов наименований электронных компонентов;
- Поставка сложных, дефицитных, либо снятых с производства позиций;
- Оперативные сроки поставки под заказ (от 5 рабочих дней);
- Экспресс доставка в любую точку России;
- Техническая поддержка проекта, помощь в подборе аналогов, поставка прототипов;
- Система менеджмента качества сертифицирована по Международному стандарту ISO 9001;
- Лицензия ФСБ на осуществление работ с использованием сведений, составляющих государственную тайну;
- Поставка специализированных компонентов (Xilinx, Altera, Analog Devices, Intersil, Interpoint, Microsemi, Aeroflex, Peregrine, Syfer, Eurofarad, Texas Instrument, Miteq, Cobham, E2V, MA-COM, Hittite, Mini-Circuits, General Dynamics и др.);

Помимо этого, одним из направлений компании «ЭлектроПласт» является направление «Источники питания». Мы предлагаем Вам помощь Конструкторского отдела:

- Подбор оптимального решения, техническое обоснование при выборе компонента;
- Подбор аналогов;
- Консультации по применению компонента;
- Поставка образцов и прототипов;
- Техническая поддержка проекта;
- Защита от снятия компонента с производства.



Как с нами связаться

Телефон: 8 (812) 309 58 32 (многоканальный)

Факс: 8 (812) 320-02-42

Электронная почта: org@eplast1.ru

Адрес: 198099, г. Санкт-Петербург, ул. Калинина, дом 2, корпус 4, литера А.