

Digital Controller E5AK/E5EK

Advanced Digital Controllers Ideal for Worldwide Use

- Modular structure
- High-accuracy: 100 ms sampling (for analog input)
- Auto-tuning and fuzzy self-tuning
- Conforms to international EMC and safety standards.
- IP66/NEMA4 (indoor use) front face
- Remote set point
- Serial communications (RS-232C, RS-422 and RS-485) and transfer output (4 to 20 mA)
- Position-proportional control model
- Heating/cooling control
- AC/DC24V types are also available.



Model Number Structure

■ Model Number Legend

E5□K- □□□ □ -500

1 2 3

1. Size

- A: 96 × 96 mm
- E: 96 × 48 mm

2. Model

- AA: Standard model
- PRR: Position-proportional model

3. Number of alarms

- 2: Two alarms

Ordering Information

■ List of Models

Description	Model	Specification
Base Unit	E5AK-AA2 AC100-240	Standard model
	E5AK-AA2-500 AC100-240	Standard model with terminal cover
	E5AK-AA2 AC/DC24	Standard model
	E5AK-AA2-500 AC/DC24	Standard model with terminal cover
	E5AK-PRR2 AC100-240	Position-proportional model
	E5AK-PRR2-500 AC100-240	Position-proportional model with terminal cover
	E5AK-PRR2 AC/DC24	Position-proportional model
	E5AK-PRR2-500 AC/DC24	Position-proportional model with terminal cover
	E5EK-AA2 AC100-240	Standard model
	E5EK-AA2-500 AC100-240	Standard model with terminal cover
	E5EK-AA2 AC/DC24	Standard model
	E5EK-AA2-500 AC/DC24	Standard model with terminal cover
	E5EK-PRR2 AC100-240	Position-proportional model
	E5EK-PRR2-500 AC100-240	Position-proportional model with terminal cover
	E5EK-PRR2 AC/DC24	Position-proportional model
	E5EK-PRR2-500 AC/DC24	Position-proportional model with terminal cover

- Note:**
1. When using the heater burnout alarm function with a standard model, the Linear Output Unit cannot be used for the control outputs (heat).
 2. Be sure to specify the Current Transformer, Output Unit, and Option Unit when ordering.
 3. The Digital Controller provides transfer outputs at 4 to 20 mA for the PV and other values and control outputs at 4 to 20 mA for the current outputs.

Description	Model	Specification
Output Unit	E53-R	Relay
	E53-S	SSR
	E53-Q	Pulse (NPN) 12 VDC
	E53-Q3	Pulse (NPN) 24 VDC
	E53-Q4	Pulse (PNP) 24 VDC
	E53-C3	Linear (4 to 20 mA)
	E53-C3D	Linear (0 to 20 mA)
	E53-V34	Linear (0 to 10 V)
	E53-V35	Linear (0 to 5 V)

Note: The Digital Controller uses a dedicated, high-resolution Output Unit. The E53-C Current Output Unit for the E5□X cannot be used with the Digital Controller.

Description	Model	Specification
Option Unit	E53-AKB	Event input
	E53-EN01	Communication (RS-232C)
	E53-EN02	Communication (RS-422)
	E53-EN03	Communication (RS-485)
	E53-AKF	Transfer output

- Note:**
1. The Option Unit can be used either by the E5AK or E5EK.
 2. The E5AK allows a maximum of three Option Units to be mounted. Refer to page 8 for mounting combinations.
The E5EK allows only one Option Unit to be mounted.

Inspection Report

The Digital Controller can be provided together with an inspection report.

Refer to the following legend with the suffix "K" when ordering a model provided together with an inspection report.

E5□K-AA2-K, E5□K-PRR2-K, E53-AKF-K

■ Accessories (Order Separately)

Name	Model	Hole diameter
Current Transformer	E54-CT1	5.8 mm
	E54-CT3	12.0 mm

Note: No CT is required unless the heater burnout alarm function is used.

Name	Model	Connectable models
Terminal Cover	E53-COV0809	E5AK
	E53-COV08	E5EK

Specifications

■ Ratings

Item	AC100-240V type	AC/DC24V type
Supply voltage	AC100 to 240V, 50/60 Hz	AC/DC24V, 50/60 Hz
Power consumption	E5AK: 16 VA E5EK: 15 VA	12 VA, 8 W
Operating voltage range	85% to 110% of rated supply voltage	
Input	Thermocouple: K, J, T, E, L, U, N, R, S, B, W, PLII Platinum resistance thermometer: JPt100, Pt100 Current input: 4 to 20 mA, 0 to 20 mA Voltage input: 1 to 5 V, 0 to 5 V, 0 to 10 V	
Input impedance	Current input: 150 Ω; Voltage input: 1 MΩ min.	
Control output	<u>Standard Model</u> According to Output Unit (see "Output Unit Ratings and Characteristics") <u>Position-proportional Model</u> 2 Relay outputs: SPST-NO, 1 A at 250 VAC (including inrush current) (see note 1)	
Auxiliary output	SPST-NO, 3 A at 250 VAC (resistive load)	
Control method (see note 2)	ON/OFF or 2-PID control (with auto-tuning)	
Setting method	Digital setting using front panel keys	
Indication method	7-segment digital display and LEDs	
Potentiometer	100 Ω to 2.5 kΩ	
Event input	Contact input: ON: 1 kΩ max., OFF: 100 kΩ min. No-contact input: ON: residual voltage: 1.5 V max., OFF: leakage current: 0.1 mA max.	
Transfer output	4 to 20 mA, permissible load impedance: 600 Ω max., resolution: approx. 2,600	
Remote SP input	Current input: 4 to 20 mA (Input impedance: 150 Ω)	
Current Transformer input	Connect an exclusive Current Transformer (E54-CT1 or E54-CT3)	
Other functions	<u>Standard</u> Manual output, heating/cooling control, SP limiter, loop burnout alarm, SP ramp, MV limiter, MV change rate limiter, input digital filter, input shift, run/stop, protect functions <u>Option</u> Multiple SP, run/stop selection, transfer output functions	
Degree of protection	Conforms to IEC IP66 and NEMA4 (Indoor use)	

Note: 1. All control outputs are insulated from the input circuit.

2. Fuzzy self-tuning is available when using the Digital Controller in standard control operation with temperature input.

■ Input Ranges

Platinum Resistance Thermometer

Input (switch selectable)		JPt100	Pt100
Range	°C	-199.9 to 650.0	-199.9 to 650.0
	°F	-199.9 to 999.9	-199.9 to 999.9
Setting		0	1

Thermocouple

Input (switch selectable) (see note)		K1	K2	J1	J2	T	E	L1	L2	U	N	R	S	B	W	PLII
Range	°C	-200 to 1,300	0.0 to 500.0	-100 to 850	0.0 to 400.0	-199.9 to 400.0	0 to 600	-100 to 850	0.0 to 400.0	-199.9 to 400.0	-200 to 1,300	0 to 1,700	0 to 1,700	100 to 1,800	0 to 2,300	0 to 1,300
	°F	-300 to 2,300	0.0 to 900.0	-100 to 1,500	0.0 to 750.0	-199.9 to 700.0	0 to 1,100	-100 to 1,500	0.0 to 750.0	-199.9 to 700.0	-300 to 2,300	0 to 3,000	0 to 3,000	300 to 3,200	0 to 4,100	0 to 2,300
Setting		2	3	4	5	6	7	8	9	10	11	12	13	14	15	16

Note: Setting number is factory-set to 2 (K1).
Thermocouple W is W/Re5-26 (tungsten rhenium 5, tungsten rhenium 26).

Current/Voltage

Input (switch selectable)	Current input		Voltage input		
	4 to 20 mA	0 to 20 mA	1 to 5 V	0 to 5 V	0 to 10 V
Range	One of following ranges depending on results of scaling -1999 to 9999 -199.9 to 999.9 -19.99 to 99.99 -1.999 to 9.999				
Setting	17	18	19	20	21

■ Characteristics

Indication accuracy (see note 1)	Thermocouple: (±0.3% of indication value or ±1°C, whichever greater) ±1 digit max. Platinum resistance thermometer: (±0.2% of indication value or ±0.8°C, whichever greater) ±1 digit max. Analog input: ±0.2% FS ±1 digit max.
Hysteresis	0.01% to 99.99% FS (in units of 0.01% FS)
Proportional band (P)	0.1% to 999.9% FS (in units of 0.1% FS)
Integral (reset) time (I)	0 to 3,999 s (in units of 1 s)
Derivative (rate) time (D)	0 to 3,999 s (in units of 1 s)
Control period	1 to 99 s (in units of 1 s)
Manual reset value	0.0% to 100.0% (in units of 0.1%)
Alarm setting range	-1,999 to 9,999 or -199.9 or 999.9 (decimal point position dependent on input type or result of scaling)
Sampling period (see note 2)	Temperature input: 250 ms Current/voltage input: 100 ms
Insulation resistance	20 MΩ min. (at 500 VDC)
Dielectric strength	2,000 VAC, 50/60 Hz for 1 min between terminals of different polarities
Vibration resistance	Malfunction: 10 to 55 Hz, 10 m/s ² (approx. 1G) for 10 min each in X, Y, and Z directions Destruction: 10 to 55 Hz, 20 m/s ² (approx. 2G) for 2 hrs each in X, Y, and Z directions
Shock resistance	Malfunction: 200 m/s ² min. (approx. 20G), 3 times each in 6 directions (100 m/s ² (approx. 10G) applied to the relay) Destruction: 300 m/s ² min. (approx. 30G), 3 times each in 6 directions
Ambient temperature	Operating: -10°C to 55°C (with no icing)/3-year warranty period: -10°C to 50°C Storage: -25°C to 65°C (with no icing)
Ambient humidity	Operating: 35% to 85%
Degree of protection	Front panel: NEMA4 for indoor use (equivalent to IP66) Rear case: IEC standard IP20 Terminals: IEC standard IP00
Memory protection	Non-volatile memory (number of writings: 100,000 operations)
Weight	E5AK: approx. 450 g E5EK: approx. 320 g Mounting bracket: approx. 65 g
EMC	Emission Enclosure: EN55011 Group 1 class A Emission AC Mains: EN55011 Group 1 class A Immunity ESD: EN61000-4-2: 4 kV contact discharge (level 2) 8 kV air discharge (level 3) Immunity RF-interference: ENV50140: 10 V/m (amplitude modulated, 80 MHz to 1 GHz) (level 3) 10 V/m (pulse modulated, 900 MHz) Immunity Conducted Disturbance: ENV50141: 10 V (0.15 to 80 MHz) (level 3) Immunity Burst: EN61000-4-4: 2 kV power-line (level 3) 2 kV I/O signal-line (level 4)
Approved standards	UL1092, CSA22.2 No. 142, CSA22.2 No. 1010-1 Conforms to EN50081-2, EN50082-2, EN61010-1 (IEC1010-1) Conforms to VDE0106/part 100 (Finger Protection), when the separately-ordered terminal cover is mounted.

- Note: 1.** The indication accuracy of the K1, T, and N thermocouples at a temperature of -100°C or less is ±2°C ±1 digit maximum. The indication accuracy of the U, L1, and L2 thermocouples at any temperature is ±2°C ±1 digit maximum.
The indication accuracy of the B thermocouple at a temperature of 400°C or less is unrestricted.
The indication accuracy of the R and S thermocouples at a temperature of 200°C or less is ±3°C ±1 digit maximum.
The indication accuracy of the W thermocouple at any temperature is (±0.3% of the indicated value or ±3°C, whichever is greater) ±1 digit maximum.
The indication accuracy of the PLII thermocouple at any temperature is (±0.3% or ±2°C, whichever is greater) ±1 digit maximum.
- 2.** The sampling period of the standard model with CT and remote SP inputs is 250 ms.

■ Output Unit Ratings and Characteristics

Relay output	5 A at 250 VAC (resistive load)
SSR output	1 A at 75 to 250 VAC (resistive load)
Voltage output	NPN: 40 mA at 12 VDC (with short-circuit protection) NPN: 20 mA at 24 VDC (with short-circuit protection) PNP: 20 mA at 24 VDC (with short-circuit protection)
Linear current output	4 to 20 mA, permissible load impedance: 600 Ω max., resolution: approx. 2,600 0 to 20 mA, permissible load impedance: 600 Ω max., resolution: approx. 2,600
Linear voltage output	0 to 10 VDC, permissible load impedance: 1 kΩ max., resolution: approx. 2,600 0 to 5 VDC, permissible load impedance: 1 kΩ max., resolution: approx. 2,600

Note: An output relay (1 A at 250 VAC) is mounted on the position-proportional model. (When replacing, use the E53-R.)

■ Option Unit Ratings and Characteristics

Event inputs	Contact input: ON: 1 kΩ max., OFF: 100 kΩ min. No-contact input: ON: residual voltage 1.5 V max., OFF: leakage current 0.1 mA max.
Communications	Interface: RS-232C, RS-422 or RS-485 Transmission method: Half-duplex Synchronization method: Start-stop synchronization (asynchronous method) Baud rate: 1.2/2.4/4.8/9.6/19.2 kbps Transmission code: ASCII
Transfer output	4 to 20 mA: Permissible load impedance: 600 Ω max. Resolution: approx. 2,600

■ Current Transformer Ratings

Dielectric strength	1,000 VAC (for 1 min)
Vibration resistance	50 Hz, 98 m/s ² (10G)
Weight	E54-CT1: approx. 11.5 g; E54-CT3: approx. 50 g
Accessories (E54-CT3 only)	Armature: 2; Plug: 2

■ Heater Burnout Alarm

Max. heater current	Single-phase 50 A VAC (see note 1)
Heater current value display accuracy	±5% FS±1 digit max.
Heater burnout alarm setting range	0.1 to 49.9 A (in units of 0.1 A) (see note 2)
Min. detection ON time	190 ms (see note 3)

Note: 1. Use the K2CU-F□□A-□GS (with gate input terminals) for the detection of three-phase heater burnout.

2. The heater burnout alarm is always OFF if the alarm is set to 0.0 A and always ON if the alarm is set to 50.0 A.

3. No heater burnout detection or heater current value measurement is possible if the control output (heat) is ON for less than 190 ms.

Nomenclature

E5AK

Operation Indicators

- OUT1
Lights when the pulse output function assigned to control output 1 turns ON.
- OUT2
Lights when the pulse output function assigned to control output 2 turns ON.
- SUB1
Lights when the output function assigned to auxiliary output 1 turns ON.
- SUB2
Lights when the output function assigned to auxiliary output 2 turns ON.
- MANU
Lights when the manual operation mode.
- STOP
Lights during operation has stopped.
- RMT
Lights during remote operation.
- AT
Flashes during auto-tuning.
- RSP
Lights during remote SP operation.
- Bar Graph
On a standard model (E5AK-AA2), this bar graph indicates the manipulated variable (heat) in 10% increments per single segment. On a position-proportional model (E5AK-PRR2), this bar graph indicates the valve opening in 10% increments per single segment.

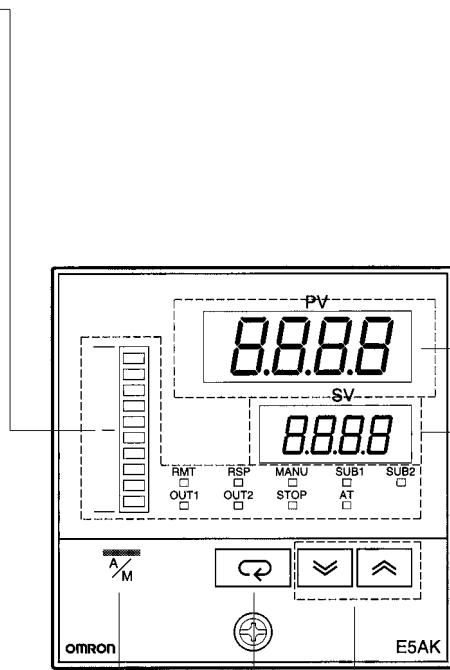

No. 1 Display

Displays the process value or parameter symbols.

No. 2 Display

Displays the set point, manipulated variable, or parameter settings.

Up Key/Down Key

Press to increase or decrease the value on the No.2 display.

Display Key

Press for less than 1 s to shift the display to the next parameter. When this key is pressed for 1 s or more, the menu screen will be displayed in any case.

A/M Key

Press to select the auto operation or manual operation.

E5EK

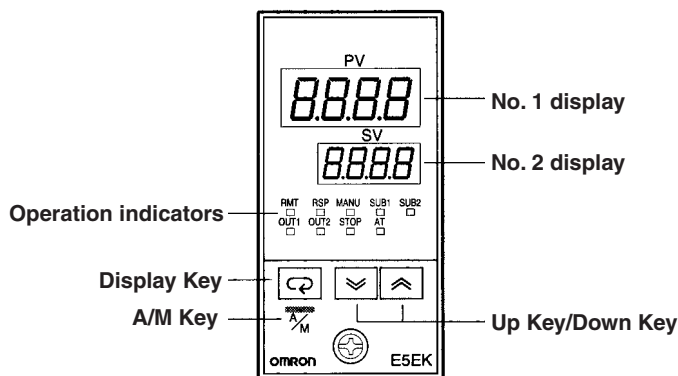

No. 1 display

No. 2 display

Operation indicators

Display Key

A/M Key

Up Key/Down Key

Dimensions

Note: All units are in millimeters unless otherwise indicated.

E5AK

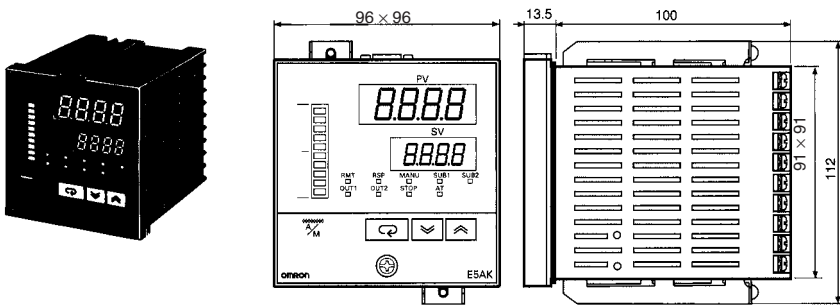

Panel Cutouts

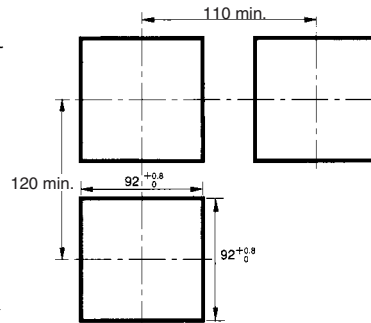

- Note:
1. Recommended panel thickness is 1 to 8 mm.
 2. Maintain the specified vertical and horizontal mounting space between each Unit. Units must not be closely mounted vertically or horizontally.

E5EK

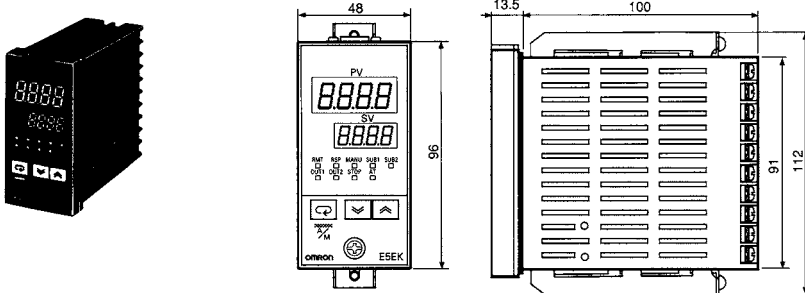

Panel Cutouts

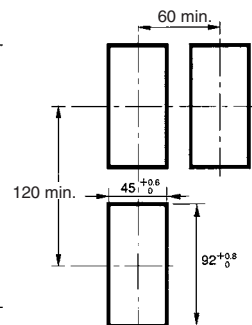

- Note:
1. Recommended panel thickness is 1 to 8 mm.
 2. Maintain the specified vertical and horizontal mounting space between each Unit. Units must not be closely mounted vertically or horizontally.

Accessories (Order Separately)

Terminal Cover

E53-COV0809

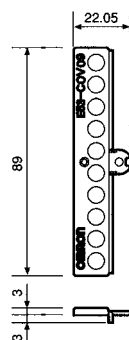
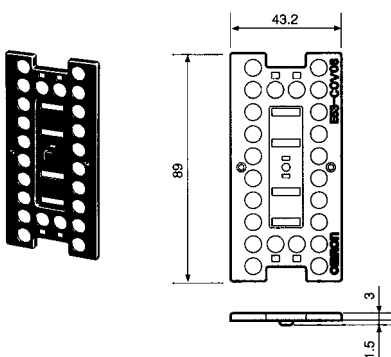

E53-COV08

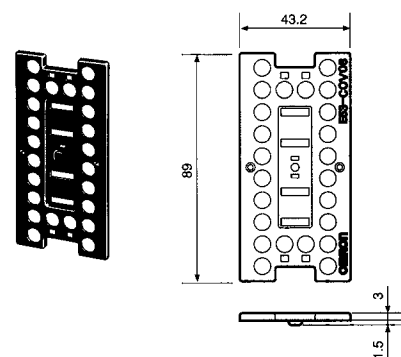

Current Transformer
E54-CT1

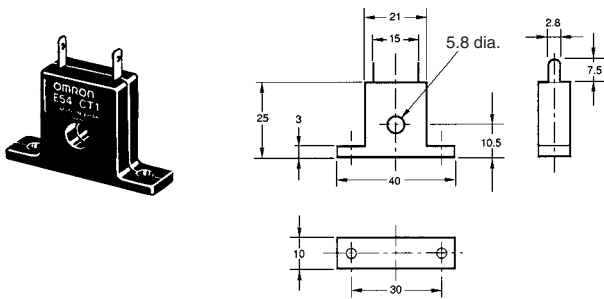

E54-CT3

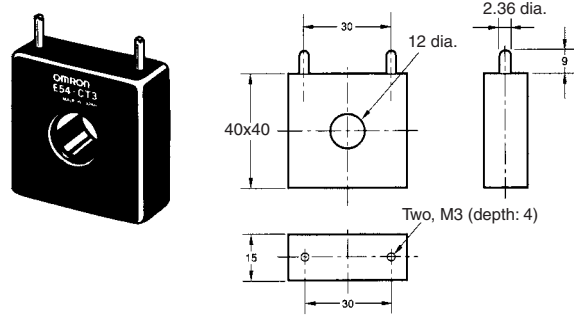

Installation

Note: Always turn off the power supply to the Digital Controller before changing any switch settings.

Settings

On a standard model, set up the Output Units for control outputs 1 and 2 before mounting the Controller.

On a position-proportional model, the Relay Output Unit is already set. Therefore, this setup operation is unnecessary. (Do not replace with other Output Units.)

When setting up the Output Units, draw out the internal mechanism from the housing and insert the Output Units into the sockets for control outputs 1 and 2.

Setting Up the Output Unit

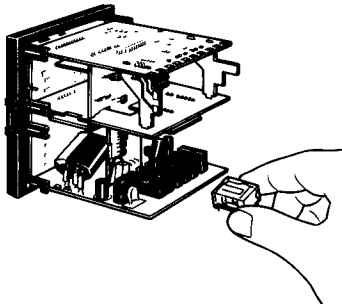

Removing the Output Unit

To replace the Output Unit, use a flat-blade screwdriver to push up the Output Unit.

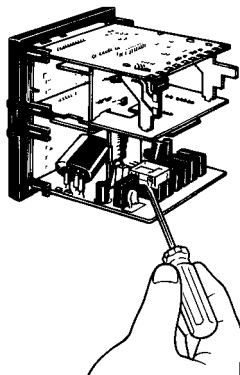

Setting Up the Option Unit

• E5AK

1. Remove the power board and option boards in the order shown in the following diagram.

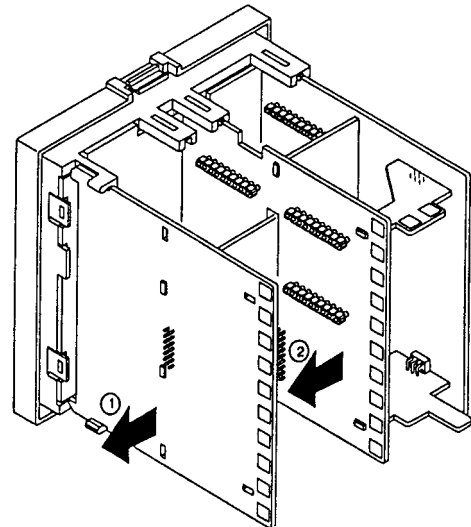

2. Insert the Option Units into the sockets for options 1 to 3. The following diagram shows the relationship between the Option Units and mounting positions.

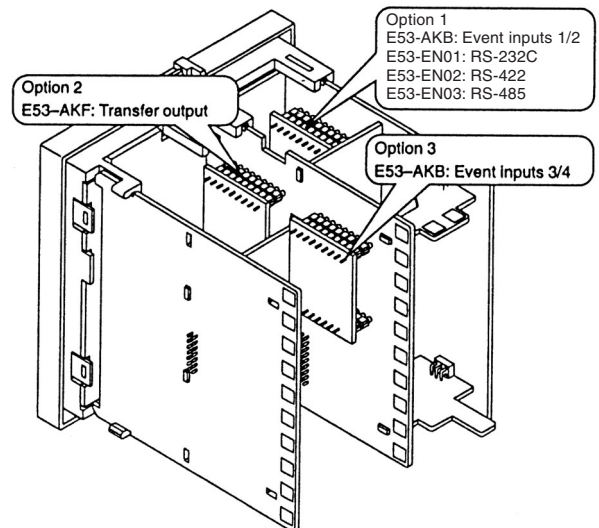

3. Mount the option boards and the power board in the order shown.

• E5EK

1. Remove the power board and option boards in the order shown in the following diagram.

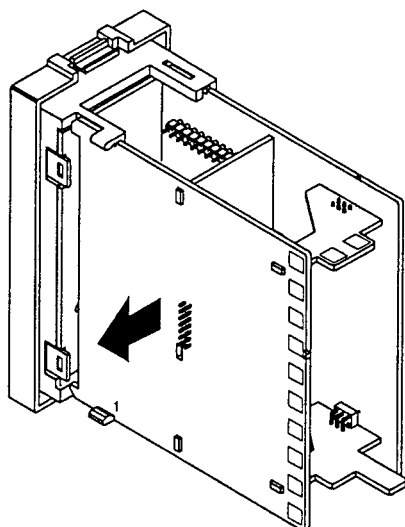

2. Insert the Option Unit into the socket for option 1. The following diagram shows the relationship between the Option Unit and mounting position.

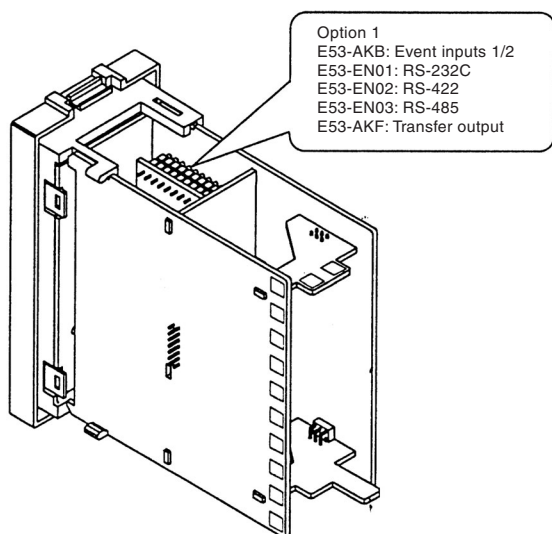

3. Mount the option board and the power board in the order shown.

Draw-out

To draw out the internal mechanism from the housing, use a Phillips screwdriver matching the screw on the lower part of the front panel.

1. Turn the screw counterclockwise while pressing the hook on the upper part of the front panel.

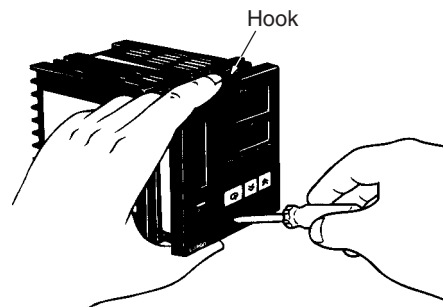

2. Draw out the internal mechanism while holding the left and right sides of the front panel.

Mounting

1. Insert the E5AK Controller into the panel's mounting hole at the position shown in the figure below.
2. Fit the mounting bracket (accessory) into the fixing slots on the top and bottom of the rear case.

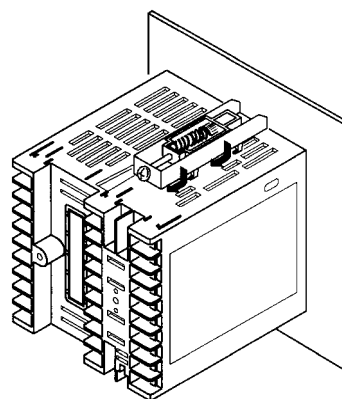

3. Tighten the mounting bracket screws on the upper and lower parts of the E5AK in small increments alternately and equally until the ratchet start to slide.

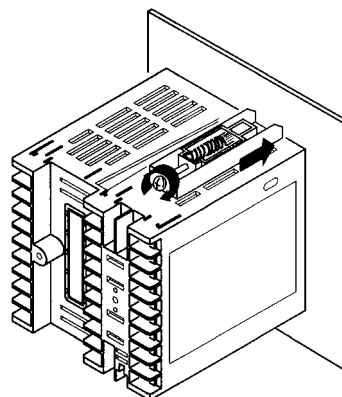

**E53-COV0809, E53-COV08 Terminal Cover
(Sold Separately)**

Fasten the terminals covers as follows by using the snap pins. Snap pins are provided with the terminal covers.

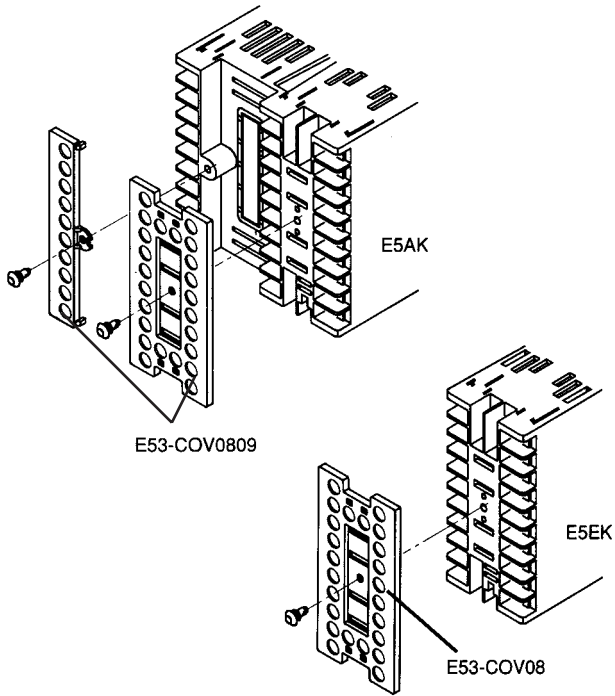

Wiring

■ Wiring Terminals for E5AK

Terminal Arrangement

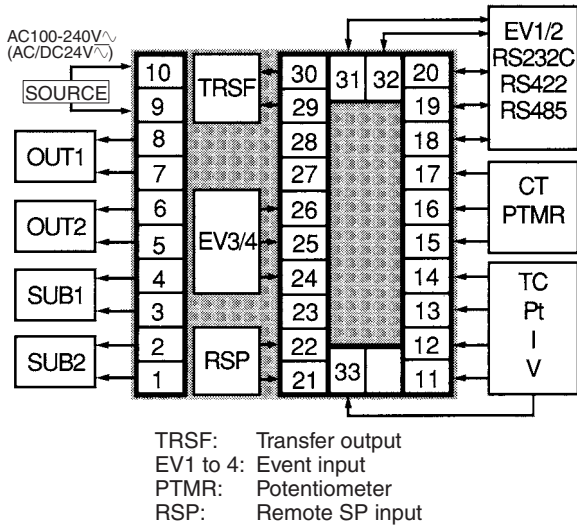

Wiring

In the following wiring diagrams, the left side of the terminal numbers indicate the inside of the Controller.

Power Supply

Input 100 to 240 VAC or AC/DC 24 V to terminal numbers 9 and 10 according to the specifications.

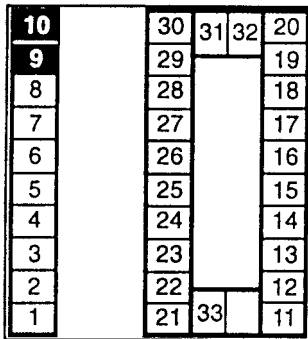

Sensor Input

Connect the sensor input to terminal numbers 11 to 14 and 33 as follows according to the input type.

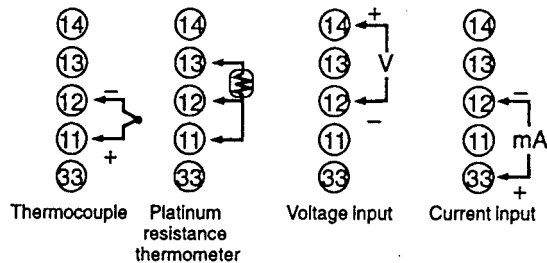
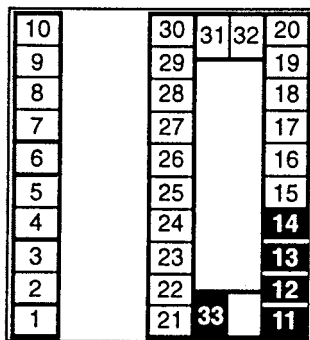

Control Output

Terminal numbers 7 and 8 are for control output 1 (OUT1), and terminal numbers 5 and 6 are for control output 2 (OUT2). The following diagrams show the available Output Units and their internal equalizing circuits.

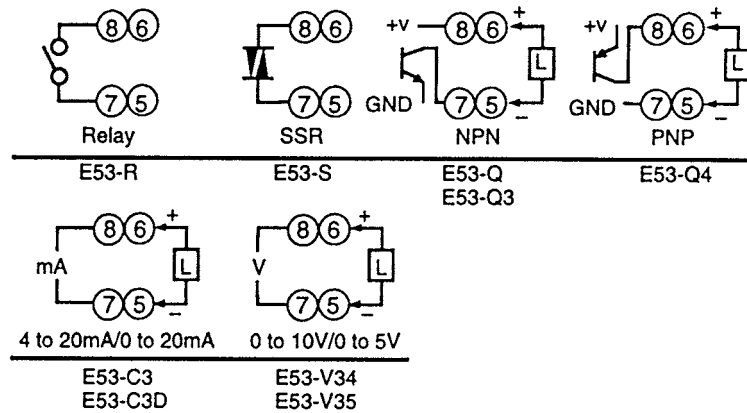
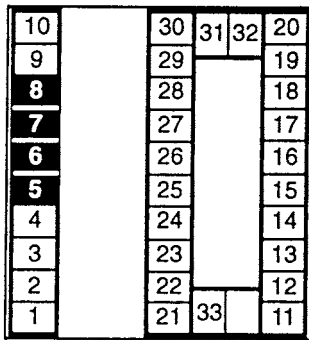

With E53-V□□ Output Units, approx. 2 V is output for one second after the power is interrupted.

The following table shows the specifications for each Output Unit.

Model	Output type	Specifications
E53-R	Relay	5 A at 250 VAC
E53-S	SSR	1 A at 75 to 250 VAC
E53-Q E53-Q3 E53-Q4	Voltage (NPN) Voltage (NPN) Voltage (PNP)	NPN: 40 mA at 12 VDC (with short-circuit protection) NPN: 20 mA at 24 VDC (with short-circuit protection) PNP: 20 mA at 24 VDC (with short-circuit protection)
E53-C3 E53-C3D	4 to 20 mA 0 to 20 mA	4 to 20 mA; permissible load impedance: 600 Ω max.; resolution: approx. 2600 0 to 20 mA; permissible load impedance: 600 Ω max.; resolution: approx. 2600
E53-V34 E53-V35	0 to 10 V 0 to 5 V	0 to 10 VDC; permissible load impedance: 1 kΩ min.; resolution: approx. 2600 0 to 5 VDC; permissible load impedance: 1 kΩ min.; resolution: approx. 2600

With E5AK-PRR2 Controllers, the relay output (1 A at 250 VAC) is fixed.

When replacing the Output Unit, use the E53-R. The following diagrams show the relationship between terminals and open/close relay settings.

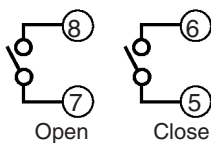

Auxiliary Output

Terminal numbers 3 and 4 are for auxiliary output 1 (SUB1) and terminal numbers 1 and 2 are for auxiliary output 2 (SUB2). The following diagrams show the internal equalizing circuits for the auxiliary outputs:

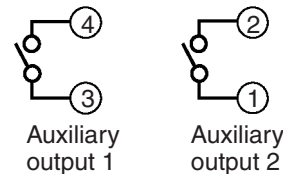
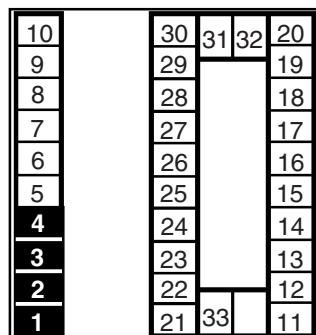

Output specifications are as follows:
SPST-NO, 3 A at 250 VAC

CT Input/Potentiometer

When using the HBA function on the E5AK-AA2 Controller, connect CT input (CT) to terminal numbers 15 to 17. When monitoring the valve opening on the E5AK-PRR2 Controller, connect the potentiometer (PTMR) to terminal numbers 15 to 17. Connect each of these inputs as follows:

10		30	31	32	20
9		29			19
8		28			18
7		27			17
6		26			16
5		25			15
4		24			14
3		23			13
2		22			12
1		21	33		11

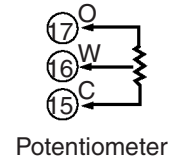
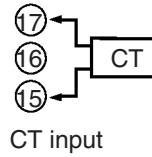

For details on CT inputs, refer to *Appendix, About Current Transformer* in the *E5AK/E5EK User's Manual (H83/H85)*. For details on the potentiometer, refer to the *Instruction Manual* for the valve connected to the Controller. The variable resistance range is 100 Ω to 2.5 kΩ.

Remote SP Input

Connect the input (RSP) to be used as the remote SP to terminal numbers 21 and 22. Only 4 to 20 mA inputs can be connected. Connect the input as follows:

10		30	31	32	20
9		29			19
8		28			18
7		27			17
6		26			16
5		25			15
4		24			14
3		23			13
2		22			12
1		21	33		11

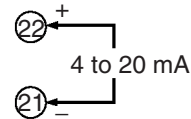

Event Input

Connect event inputs 1 and 2 (EV1/2) to terminal numbers 18 to 20, and event events 3 and 4 (EV3/4) to terminal numbers 24 to 26. However, note that terminal numbers 18 to 20 cannot be used on Controllers with a communications function. Connect the event inputs as follows:

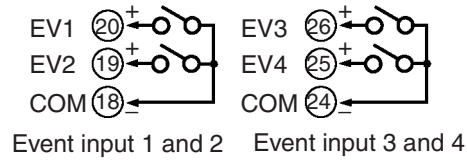
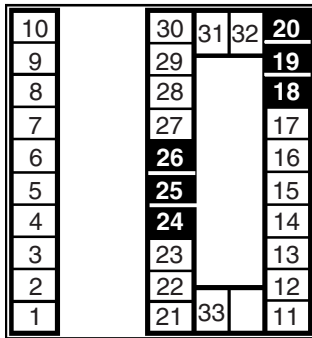

Terminals 18 and 24 (COM) are connected internally.

Use event inputs under the following conditions:

Contact input	ON: 1 kΩ max. OFF: 100 kΩ min.
No-contact input	ON: Residual voltage 1.5 V max., OFF: Leakage current 0.1 mA max.

Polarities during no-contact input are as follows:

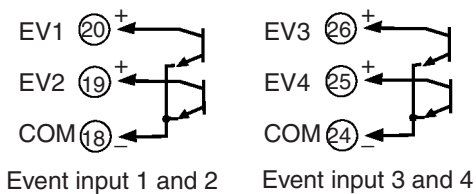

Transfer Output

Connect transfer output (TRSF) to terminal numbers 29 and 30. The internal equalizing circuit for transfer output is as follows:

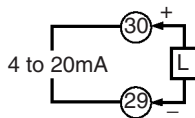

Transfer output specifications are as follows: 4 to 20 mA,
Permissible load impedance: 600 Ω max.,
Resolution: Approx. 2600

Communications

Terminal numbers 18 to 20, 31 and 32 can be used only on Controllers with Communications Units (E53-EN01/02/03). For details on wiring, refer to *Chapter 6, Using the Communications Function* in the *E5AK/E5EK User's Manual (H83/H85)*.

■ Wiring Terminals for E5EK

Terminal Arrangement

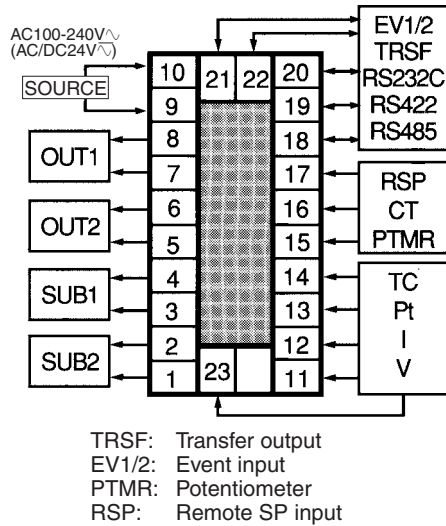

Wiring

In the following wiring diagrams, the left side of the terminal numbers indicate the inside of the Controller.

Power Supply

Input 100 to 240 VAC or AC/DC 24 V to terminal numbers 9 and 10 according to the specifications.

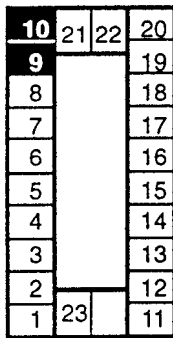

Sensor Input

Connect the sensor input to terminal numbers 11 to 14 and 23 as follows according to the input type.

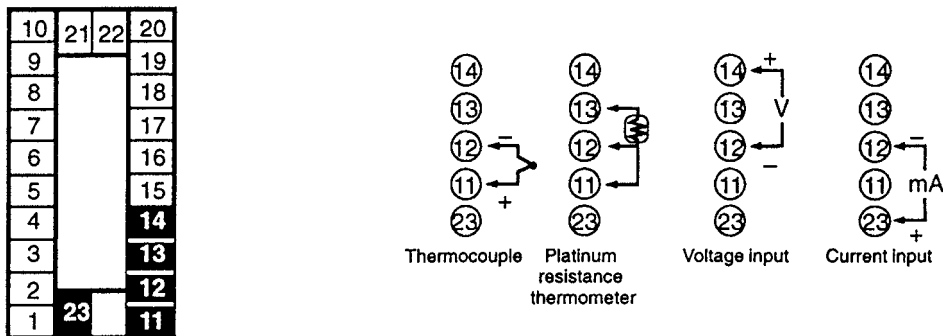

Control Output

Terminal numbers 7 and 8 are for control output 1 (OUT1), and terminal numbers 5 and 6 are for control output 2 (OUT2). The following diagrams show the available Output Units and their internal equalizing circuits.

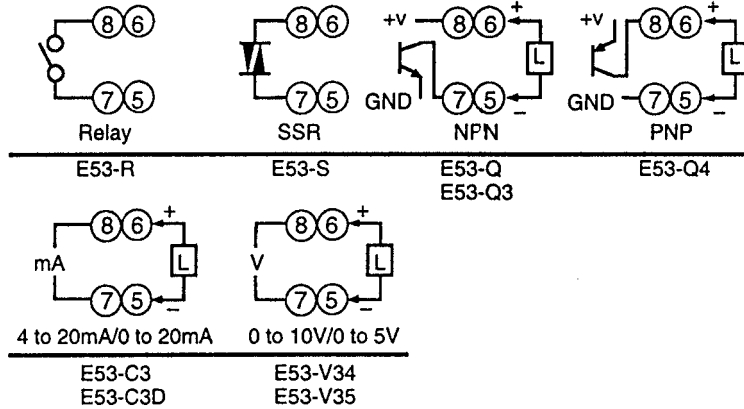
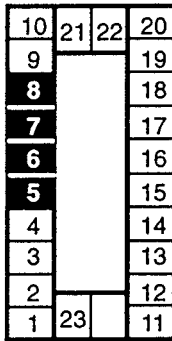

With E53-V□□ Output Units, approx. 2 V is output for one second after the power is interrupted.

The following table shows the specifications for each Output Unit.

Model	Output type	Specifications
E53-R	Relay	5 A at 250 VAC
E53-S	SSR	1 A at 75 to 250 VAC
E53-Q E53-Q3 E53-Q4	Voltage (NPN) Voltage (NPN) Voltage (PNP)	NPN: 40 mA at 12 VDC (with short-circuit protection) NPN: 20 mA at 24 VDC (with short-circuit protection) PNP: 20 mA at 24 VDC (with short-circuit protection)
E53-C3 E53-C3D	4 to 20 mA 0 to 20 mA	4 to 20 mA, permissible load impedance: 600 Ω max., resolution: approx. 2600 0 to 20 mA, permissible load impedance: 600 Ω max., resolution: approx. 2600
E53-V34 E53-V35	0 to 10 V 0 to 5 V	0 to 10 VDC, permissible load impedance: 1 kΩ min., resolution: approx. 2600 0 to 5 VDC, permissible load impedance: 1 kΩ min., resolution: approx. 2600

With E5EK-PRR2 Controllers, the relay output (1 A at 250 VAC) is fixed.

When replacing the Output Unit, use the E53-R. The following diagrams show the relationship between terminals and open/close relay settings.

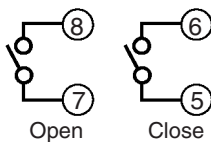

Auxiliary Output

Terminal numbers 3 and 4 are for auxiliary output 1 (SUB1) and terminal numbers 1 and 2 are for auxiliary output 2 (SUB2). The following diagrams show the internal equalizing circuits for the auxiliary outputs:

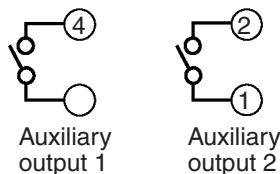
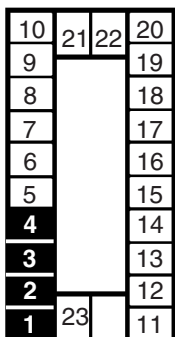

Output specifications are as follows:
SPST-NO, 3A at 250 VAC

CT Input/Potentiometer

When using the HBA function on the E5EK-AA2 Controller, connect CT input (CT) to terminal numbers 15 to 17. When monitoring the valve opening on the E5EK-PRR2 Controller, connect the potentiometer (PTMR) to terminal numbers 15 to 17. Connect each of these inputs as follows:

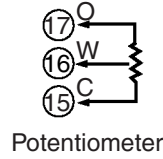
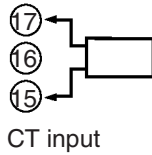
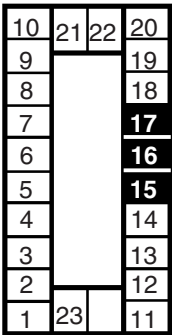

For details on CT inputs, refer to *Appendix, About Current Transformer* in the *E5AK/E5EK User's Manual (H83/H85)*. For details on the potentiometer, refer to the *Instruction Manual* for the valve connected to the Controller. The variable resistance range is 100 Ω to 2.5 kΩ.

Remote SP Input

Connect the input (RSP) to be used as the remote SP to terminal numbers 15 and 16. However, note that the remote SP cannot be used on the E5EK-PRR2 Controller. Only 4 to 20 mA inputs can be connected. Connect the input as follows:

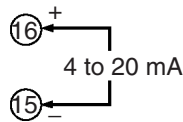
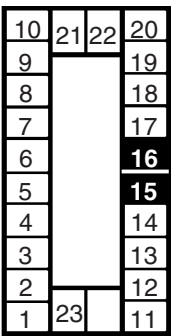

Event Input

Connect event inputs 1 and 2 (EV1/2) to terminal numbers 18 to 20. However, note that terminal numbers 18 to 20 cannot be used on Controllers with a communications function. Connect the event inputs as follows:

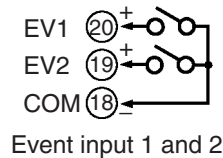
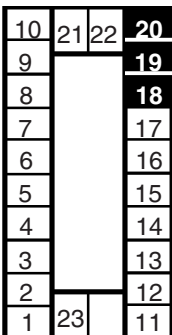

Use event inputs under the following conditions:

Contact input	ON: 1 kΩ max., OFF: 100 kΩ min.
No-contact input	ON: Residual voltage 1.5 V max., OFF: Leakage current 0.1 mA max.

Polarities during no-contact input are as follows:

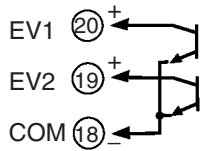

Event input 1 and 2

Transfer Output

Connect transfer output (TRSF) to terminal numbers 21 and 22. The internal equalizing circuit for transfer output is as follows:

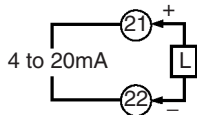

Transfer output specifications are as follows: 4 to 20 mA,
Permissible load impedance: 600 Ω max.,
Resolution: Approx. 2600

Communications

Terminal numbers 18 to 22 can be used only on controllers with Communications Units (E53-EN01/02/03). For details on wiring, refer to *Chapter 6, Using the Communications Function* in the *E5AK/E5EK User's Manual (H83/H85)*.

■ Precautions when Wiring

Use ducts to separate input leads and power lines in order to protect the Controller and its lines from external noise.

Solderless terminals are recommended when wiring the Controller.

Tighten the terminal screws using a torque no greater than 0.78 N·m, or 8 kgf·cm max. Take care not to tighten the terminal screws too tightly.

Power Blocks

The E5AK/E5EK has independent power supplies for each of the terminal blocks shown below.

E5AK

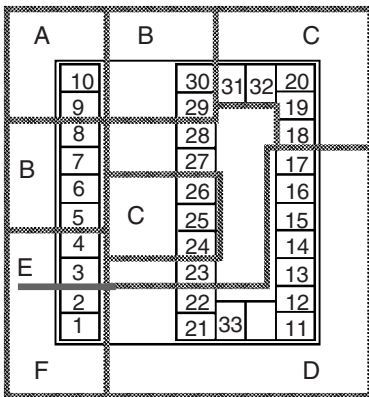

E5EK

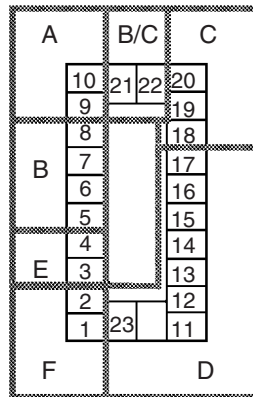

Note: Terminals 21 and 22 of the E5EK belong to the B block when a transfer output is set to option 1 and to the C block for other Option Units.

Operation

■ After Turning ON Power

Determine the I/O specifications of the Digital Controller in setup mode.

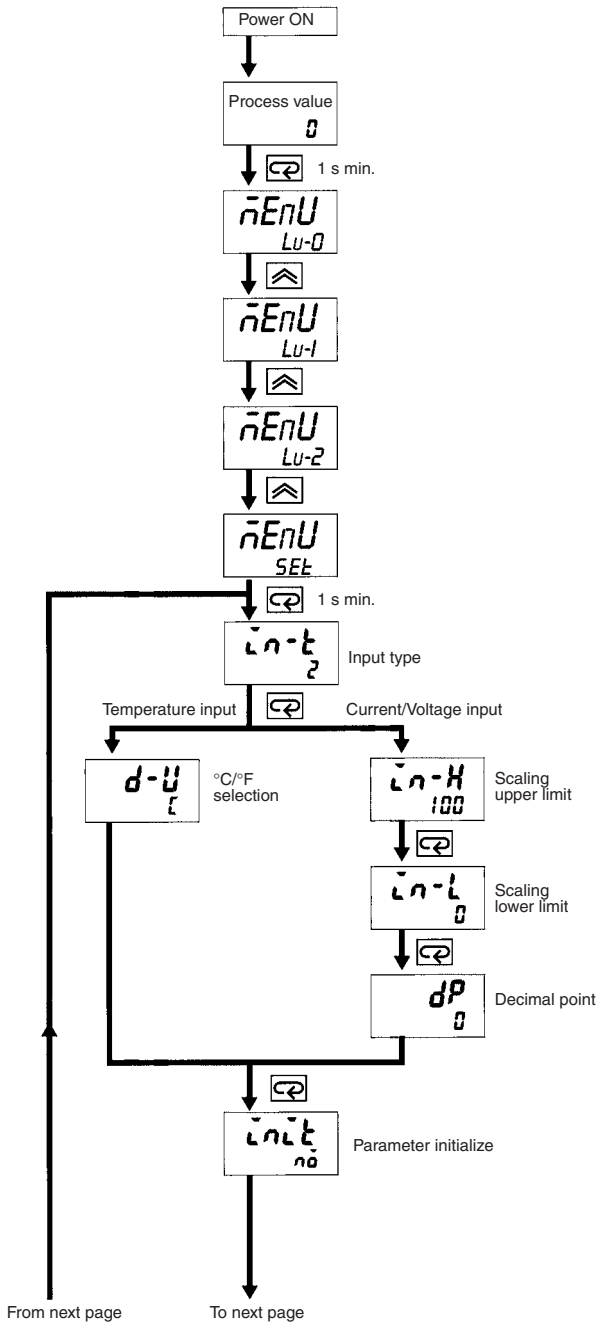

■ Input Type

Set the code according to the following table. Default is "2: K1 thermocouple."

Platinum Resistance Thermometer

Set value	Input type		
0	JPt100	-199.9 to 650.0 (°C) /-199.9 to 999.9 (°F)	Platinum resistance thermometer
1	Pt100	-199.9 to 650.0 (°C) /-199.9 to 999.9 (°F)	
2	K1	-200 to 1,300 (°C) /-300 to 2,300 (°F)	Thermocouple
3	K2	0.0 to 500.0 (°C) /0.0 to 900.0 (°F)	
4	J1	-100 to 850 (°C) /-100 to 1,500 (°F)	
5	J2	0.0 to 400.0 (°C) /0.0 to 750.0 (°F)	
6	T	-199.9 to 400.0 (°C) /-199.9 to 700.0 (°F)	
7	E	0 to 600 (°C) /0 to 1,100 (°F)	
8	L1	-100 to 850 (°C) /-100 to 1,500 (°F)	
9	L2	0.0 to 400.0 (°C) /0.0 to 750.0 (°F)	
10	U	-199.9 to 400.0 (°C) /-199.9 to 700.0 (°F)	
11	N	-200 to 1,300 (°C) /-300 to 2,300 (°F)	
12	R	0 to 1,700 (°C) /0 to 3,000 (°F)	Current input
13	S	0 to 1,700 (°C) /0 to 3,000 (°F)	
14	B	100 to 1,800 (°C) /300 to 3,200 (°F)	
15	W	0 to 2,300 (°C) /0 to 4,100 (°F)	
16	PLII	0 to 1,300 (°C) /0 to 2,300 (°F)	Voltage input
17	4 to 20 mA		
18	0 to 20 mA		
19	1 to 5 V		
20	0 to 5 V		
21	0 to 10 V		

Parameter Initialize

Parameter initialization sets all parameters to default values except for the input type, scaling upper limit, scaling lower limit, decimal point, and °C/°F selection parameters.

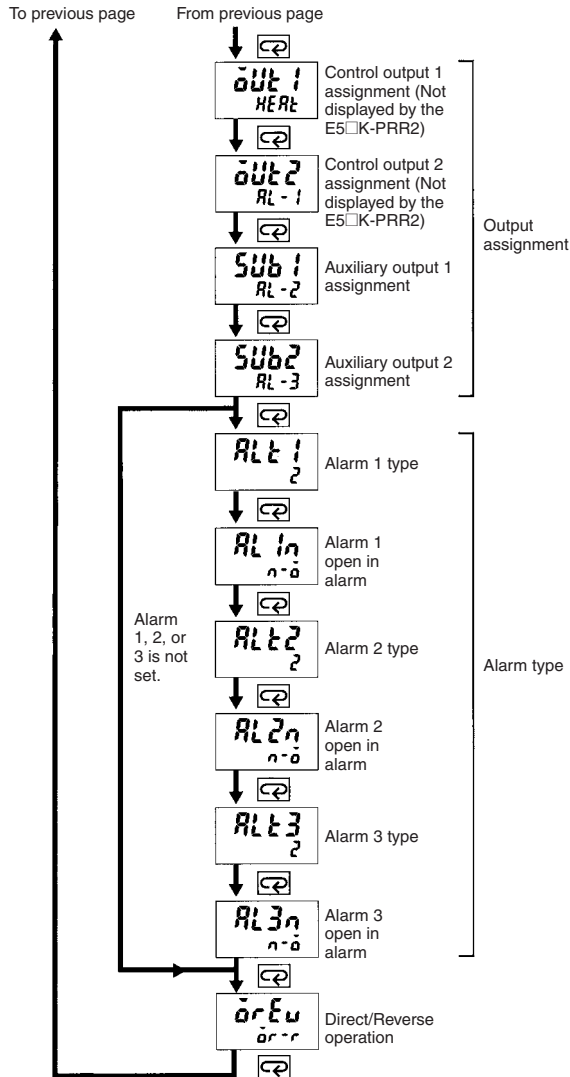

Output Assignments

Signals available as allocated outputs are the control output (heat), control output (cool), alarm 1, alarm 2, alarm 3, LBA, and HBA. The auxiliary outputs of the Digital Controller cannot be used as control outputs.

Control output (heat), control output (cool), alarm 1, alarm 2, alarm 3, LBA, error 1 (input error), error 2 (A/D converter error), and error 3 (RSP input error) output functions are available. These functions are assigned to control outputs 1 and 2 and auxiliary outputs 1 and 2.

The assignment destination of each output function is may be restricted. Refer to the following table.

Standard Models

Assignment destination \ Output function	Control output		Auxiliary output	
	1	2	1	2
Control output (heat)	Yes	Yes	---	---
Control output (cool)	Yes	Yes	---	---
Alarm 1	Yes	Yes	Yes	Yes
Alarm 2	Yes	Yes	Yes	Yes
Alarm 3	Yes	Yes	Yes	Yes
HBA	Yes	Yes	Yes	Yes
LBA	Yes	Yes	Yes	Yes
Error 1: Input error	---	---	Yes	Yes
Error 2: A/D converter error	---	---	Yes	Yes
Error 3: RSP input error	---	---	Yes	Yes

With control output (cool), the conditions for switching from standard control to heating and cooling control are reached when the output function is assigned at the cooling side during heating and cooling control.

In other words, heating and cooling control is carried out when control output (cool) is assigned, and standard control is carried out when output is not assigned.

Position-proportional Models

Assignment destination \ Output function	Control output		Auxiliary output	
	1	2	1	2
Alarm 1	---	---	Yes	Yes
Alarm 2	---	---	Yes	Yes
Alarm 3	---	---	Yes	Yes
Error 1: Input error	---	---	Yes	Yes
Error 2: A/D converter error	---	---	Yes	Yes
Error 3: RSP input error	---	---	Yes	Yes

LBA

The LBA (loop break alarm) function is available when it is assigned as an output. The LBA function is not available when a memory or A/D converter error results.

LBA is a function for determining that an error has occurred somewhere on the control loop and outputting an alarm when the process value does not change with the manipulated variable at a maximum or minimum state. Accordingly, the LBA function can be used as a means for detecting a malfunctioning control loop.

Alarm Mode Selectors

Alarm outputs are available if they are allocated as outputs. Factory setting is "2: Upper-limit alarm (deviation)."

Switch setting	Alarm operation	Alarm output	
		When X is positive	When X is negative
1	Upper- and lower-limit alarm (deviation)		Always ON
2	Upper-limit alarm (deviation)		
3	Lower-limit alarm (deviation)		
4	Upper- and lower-limit range alarm (deviation)		Always OFF
5	Upper- and lower-limit alarm with standby sequence (deviation)		Always OFF
6	Upper-limit alarm with standby sequence (deviation)		
7	Lower-limit alarm with standby sequence (deviation)		
8	Absolute-value upper-limit alarm		
9	Absolute-value lower-limit alarm		
10	Absolute-value upper-limit alarm with standby sequence		
11	Absolute-value lower-limit alarm with standby sequence		

Deviation Alarm

If the alarm mode selector is set to a number between 1 to 7, alarm values are set to the width deviated from the set point as shown in the following illustration.

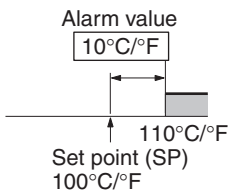

Absolute Alarm

If the alarm mode selector is set to 8 or 9, alarm values are set to the absolute value based on 0°C/°F as shown in the following illustration.

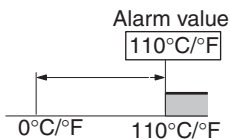

When selecting a control method, refer to the following table for correct parameter setting.

Control method	Control output 1 assignment	Control output 2 assignment	Operation
Heat	Control output (heat)	---	Reverse
Cool	Control output (heat)	---	Direct
Heat/Cool	Control output (heat)	Control output (cool)	Reverse

Close in Alarm/Open in Alarm

When the Controller is set to “close in alarm,” the status of the alarm output function is output as it is. When set to “open in alarm,” the status of the alarm output function is output inverted.

Condition	Alarm	Output	Output LED
Close in alarm	ON	ON	Lit
	OFF	OFF	Not lit
Open in alarm	ON	OFF	Lit
	OFF	ON	Not lit

Alarm type and close in alarm (normally open)/open in alarm (normally close) can be set independently from each alarm.

Close in alarm/Open in alarm is set in the “alarm 1 to 3 open in alarm” parameters (setup mode). Factory setting is “close in alarm” [$\bar{n}-\bar{o}$].

Parameter Operation List

Switching to modes other than manual or protect mode is carried out using the mode selection in the menu display.

The figure below shows all parameters in the order that they are displayed. Some parameters are not displayed depending on the protect mode setting and conditions of use.

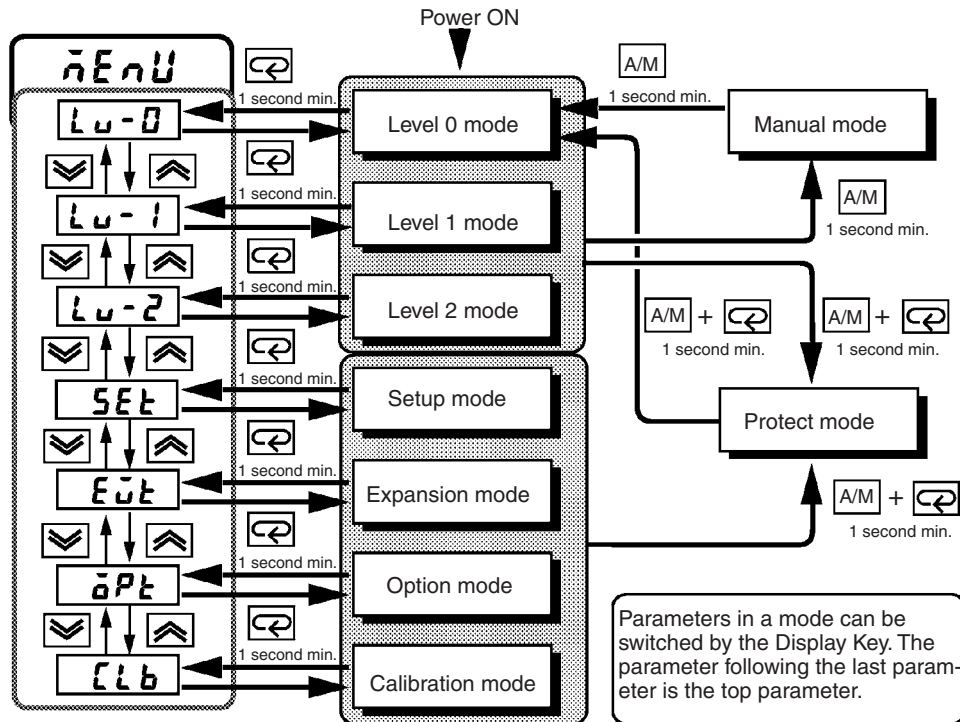

Note: The control of the Digital Controller is reset when the Digital Controller is in setup, expansion, option, or calibration mode, in which case the control and auxiliary outputs are OFF. The reset condition will be canceled when the Digital Controller is in any mode other than the above.

Parameters and Menus

Note: For more details on the functions of each part and display contents, refer to the *E5AK/E5EK User's Manual (H83/H85)*.

All functions selected with the Digital Controller in setup or expansion mode or all optional functions of the Digital Controller may not be displayed.

Protect Mode

Limits use of the menu and A/M Keys. The protect function prevents unwanted modification of parameters and switching between the auto and manual operation.

Manual Mode

The Controller can be switched to manual operation. The manipulated variable can be manipulated manually only in this mode.

Level 0 Mode	Set the Controller to this mode during normal operation. In this mode, change the set point during operation, and start or stop Controller operation. The process value, ramp SP, and manipulated variable can only be monitored in this mode.
Level 1 Mode	The main mode for adjusting control. In this mode, execute AT (auto-tuning), and set alarm values, the control period, and PID parameters.
Level 2 Mode	The auxiliary mode for adjusting control. In this mode, set the parameters for limiting the manipulated variable and set point, switch between the remote and local modes, switch between the SP mode, and set the loop break alarm (LBA), alarm hysteresis, and the digital filter value of inputs.
Setup Mode	The mode for setting the basic specifications. In this mode, set parameters that must be checked or set before operation such as the input type, scaling, output assignments and direct/reverse operation.
Expansion Mode	The mode for setting expanded functions. In this mode, set ST (self-tuning), SP setting limiter, select advanced PID or ON/OFF control, specify the standby sequence resetting method, and set the time for automatic return to the monitoring display.
Option Mode	The mode for setting option functions. Select this mode only when the Option Unit is set in the Controller. In this mode, set the communications conditions, transfer output and event input parameters to match the type of Option Unit set in the Controller. Heater burnout latch function, position-proportional travel time, and remote SP scaling parameter are also located in this mode.
Calibration Mode	The mode for calibrating inputs and transfer output. When calibrating input, the selected input type is calibrated. Whereas, transfer output can be calibrated only when the Communications Unit (E53-CKF) is set in the Controller.

Parameter Operation

Refer to the *E5AK/E5EK User's Manual (H83/H85)* for each parameter and the calibration mode in detail.

Refer to page 9 for the setting in detail.

Level 0 Mode

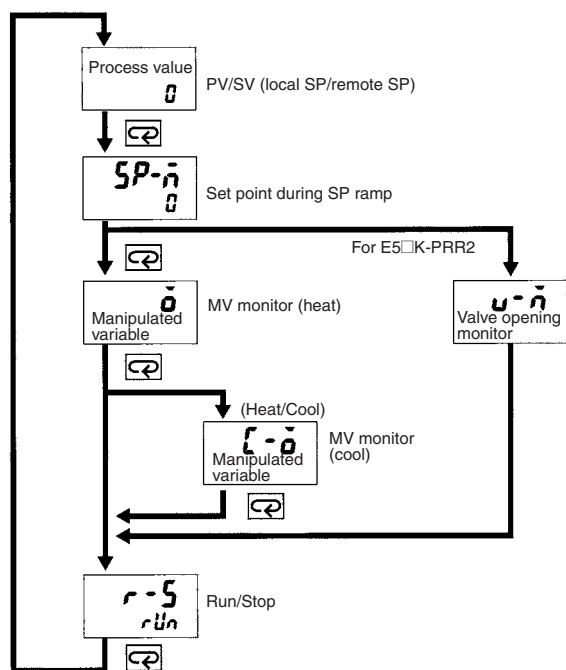

PV/SV

The process value is displayed on the No.1 display and the set point is displayed on the No.2 display.

When the multi-SP function is in use, the value of whichever is set, set point 0 or 1, is linked.

Remote SP Monitor

Monitors remote SP in the local SP mode.

Set Point During SP Ramp

Monitors the set point when the SP ramp function is used.

SP Ramp

With the SP ramp function, the Controller operates according to the value (set point during SP ramp) limited by a change rate, instead of the changed set point when the set point is changed. The interval in which the set point during SP ramp is limited is referred to as the "SP ramp."

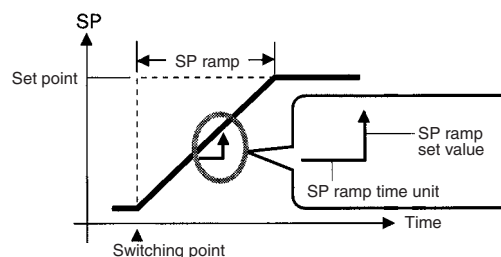

The change rate during the SP ramp is specified by the "SP ramp set value" and "SP ramp time unit" parameters. At the "SP ramp set value" default "0," the SP ramp function is disabled.

The set point changing in SP ramp can be monitored in the "Set point during SP ramp" parameter (level 0 mode).

Protect Mode

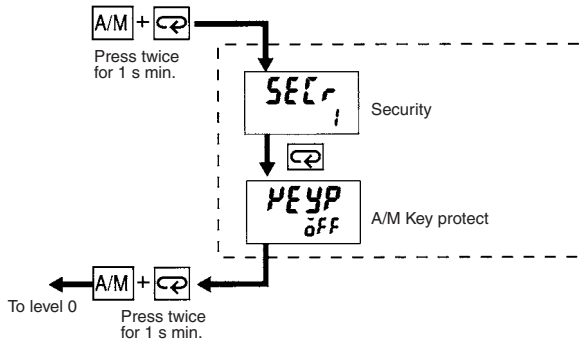

Manual Mode

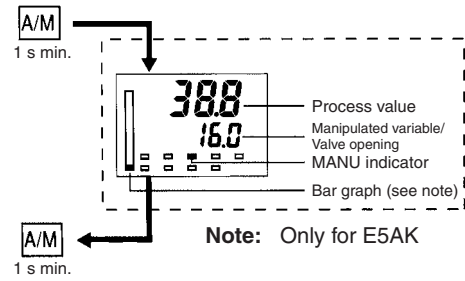

Security

Any mode marked with "X" in the following table is not displayed on the menu when this parameter is set to "0" to "3."

Mode	Set value				
	0	1	2	3	4
Calibration	---	X	X	X	X
Option	---	---	X	X	X
Expansion	---	---	X	X	X
Setup	---	---	X	X	X
Level 2	---	---	---	X	X
Level 1, 0	---	---	---	---	X

The Unit will be in only level 0 mode and the menu will not be available when this parameter is set to "4" to "6."

Only the "PV/SP" parameter in the level 0 mode can be used when this parameter is set to "5."

Only the "PV/SP" parameter in the level 0 mode can be used when this parameter is set to "6."

A/M Key Protect

Invalidate the function of the A/M Key.

Level 1 Mode

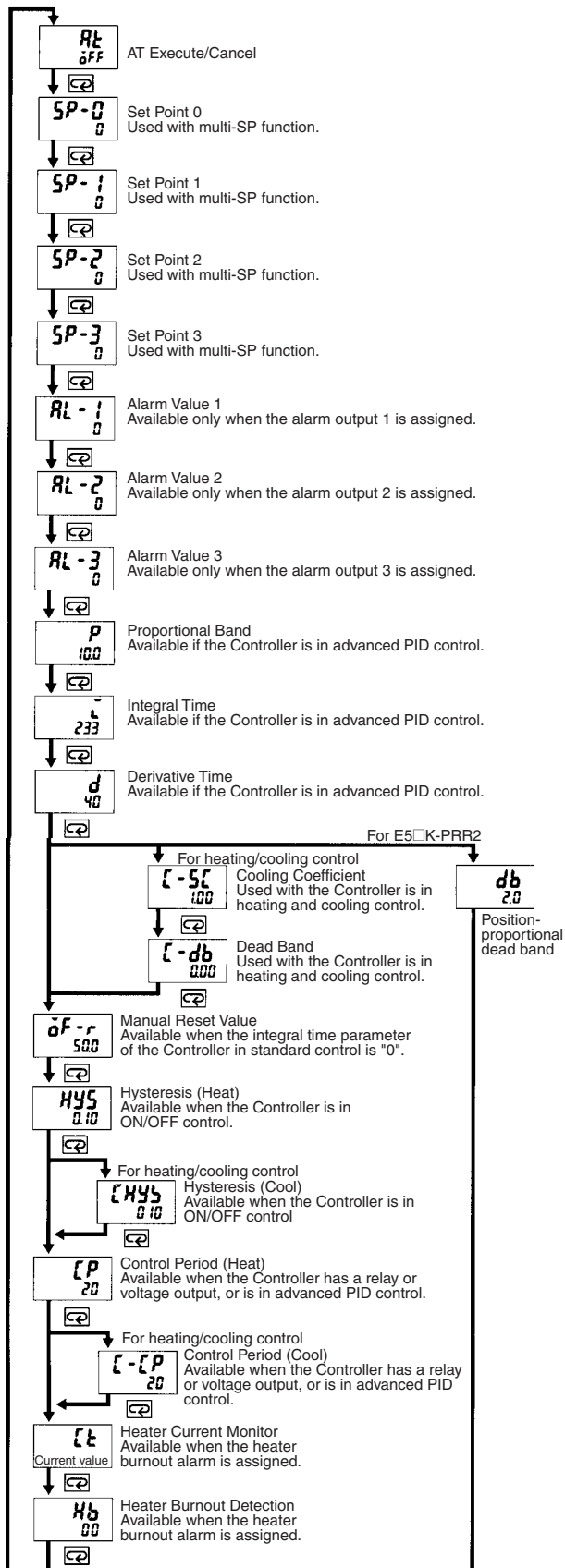

Level 2 Mode

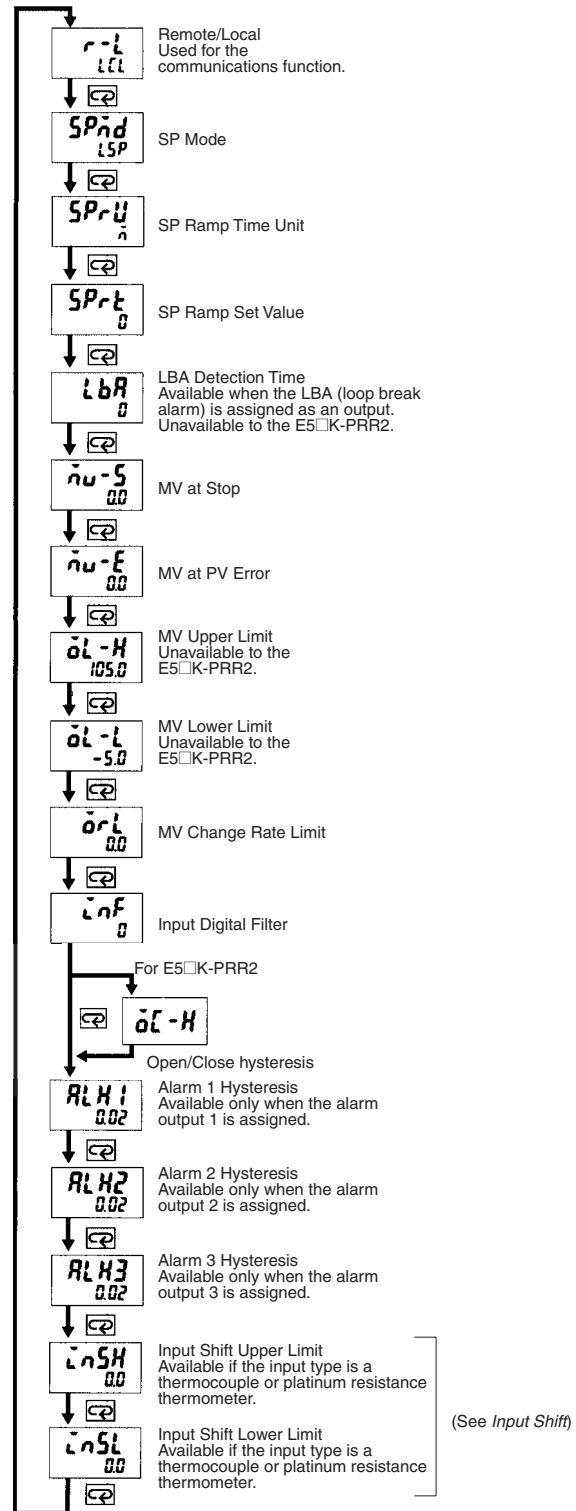

Input Shift

When temperature input is selected, scaling is not required. This is because input is treated as the “temperature” as it is matched to the input type. However, note that the upper- and lower-limit values of the sensor can be shifted. For example, if both the upper- and lower-limit values are shifted by 1.2°C, the process value (before shift) is regarded as 201.2°C after shift when input is 200°C before shift.

To set the input shift, set shift values in the “input shift upper limit” and “input shift lower limit” parameters (level 2 mode).

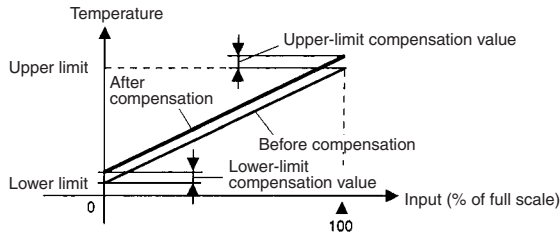

Setup Mode

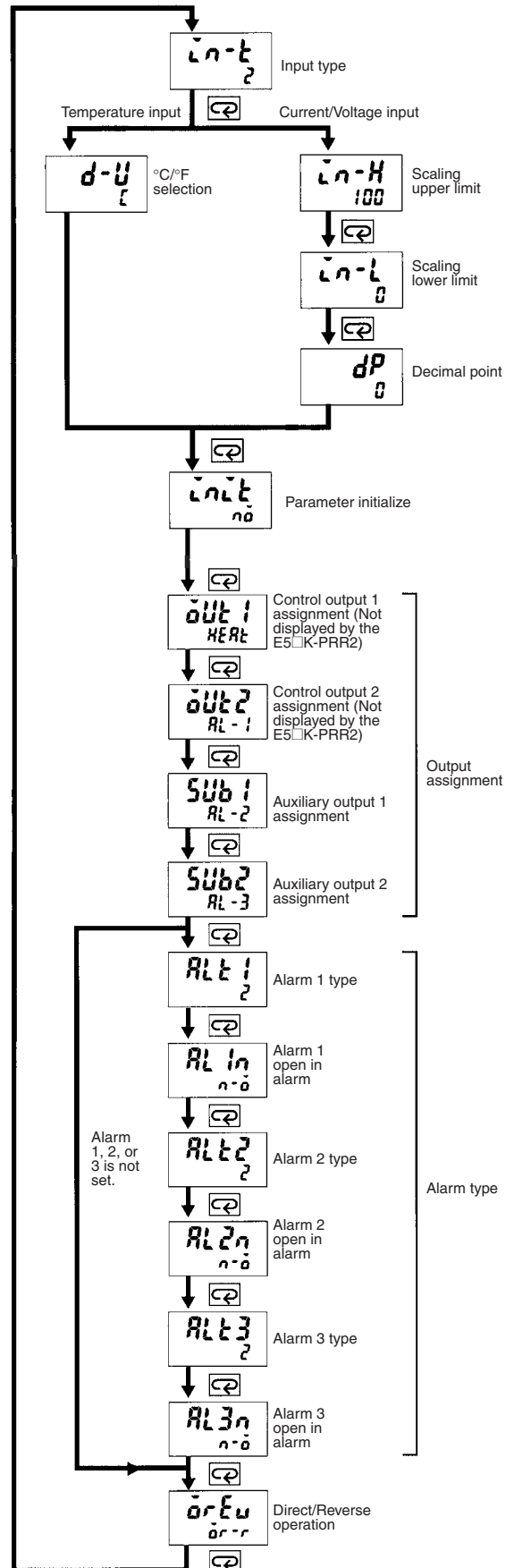

Expansion Mode

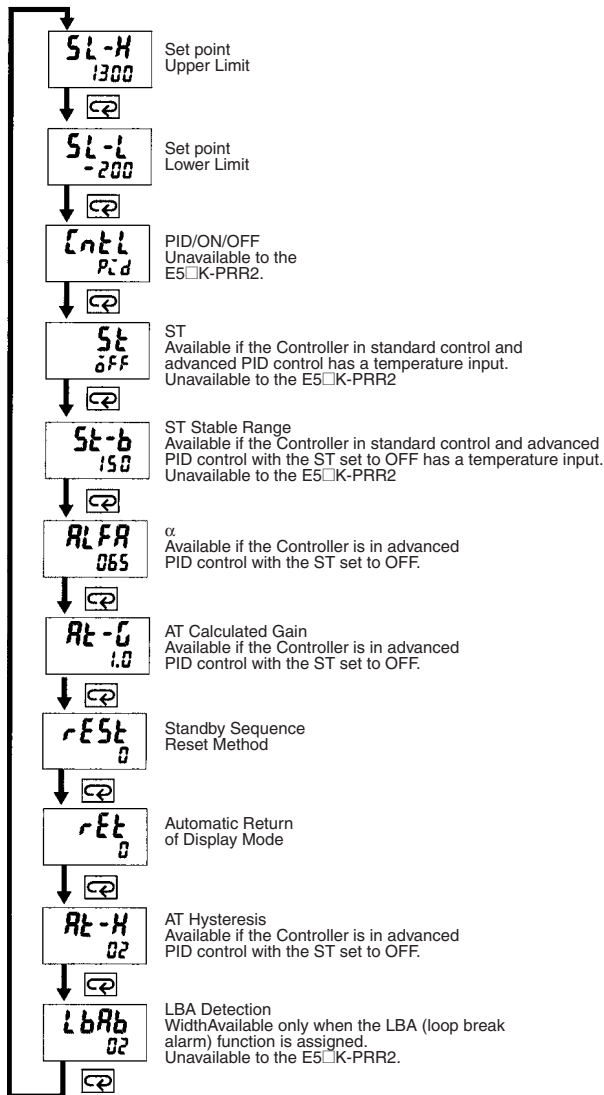

Option Mode

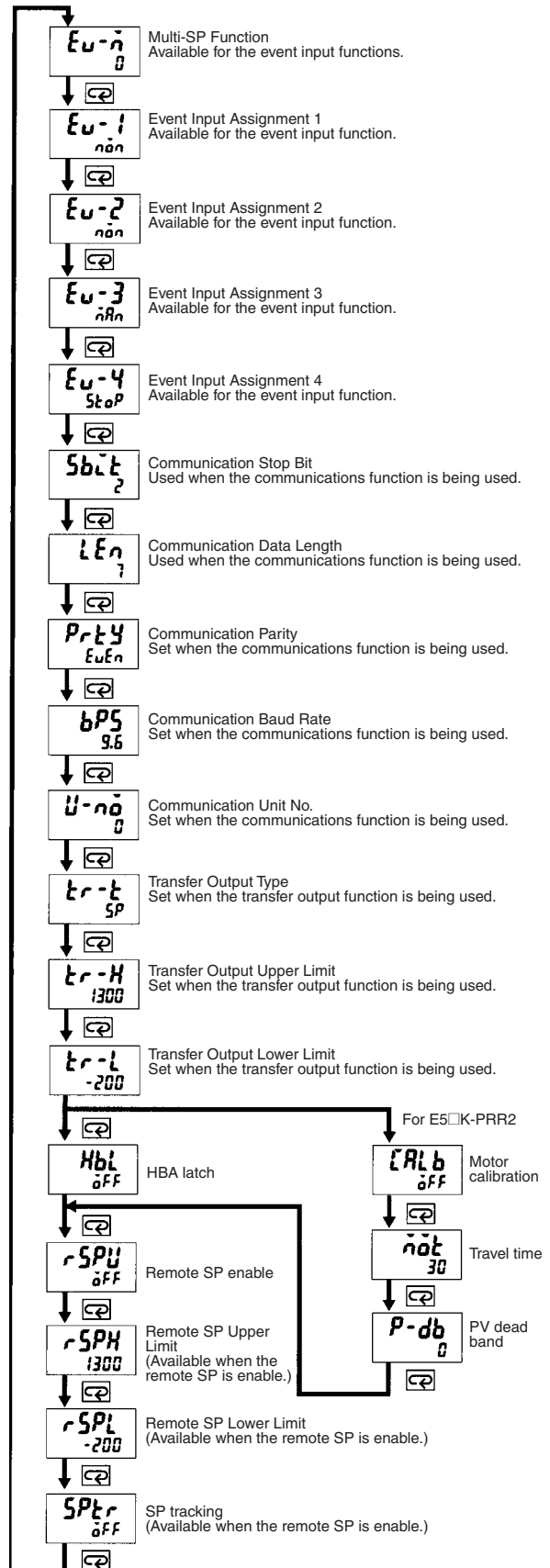

How to Use the Error Display

When an error has occurred, the No.1 display alternately indicates error codes together with the current display item. This section describes how to check error codes on the display, and the actions that must be taken to remedy the problem.

5Err **Input Error**

Meaning Input is in error.
Action Check the wiring of inputs, disconnections, and shorts, and check the input type and the input type jumper connector.
Operation at Error For control output functions, output the manipulated variable matched to the setting of the “MV at PV error” parameter (level 2 mode). Alarm output functions are activated when the upper limit is exceeded.

E111 **Memory Error**

Meaning Internal memory operation is in error
Action First, turn the power OFF then back ON again. If the display remains the same, the E5AK/E5EK Controller must be repaired. If the display is restored to normal, the probable cause may be external noise affecting the control system. Check for external noise.
Operation at Error Control output functions turn OFF (2 mA max. at 4 to 20 mA output, and output equivalent to 0% in case of other outputs). Alarm output functions turn OFF.

E333 **A/D Converter Error**

Meaning Internal circuits are in error.
Action First, turn the power OFF then back ON again. If the display remains the same, the E5AK/E5EK Controller must be repaired. If the display is restored to normal, the probable cause may be external noise affecting the control system. Check for external noise.
Operation at Error Control output functions turn OFF (2 mA max. at 4 to 20 mA output, and output equivalent to 0% in case of other outputs). Alarm output functions turn OFF.

AErr **Calibration Data Error**

Meaning This error is output only during temperature input and is displayed for two seconds when the power is turned ON. Calibration data is in error.
Action Must repair.
Operation at Error Both control output functions and alarm output functions are active. However, note that the readout accuracy is not assured.

CCCC
3333 **Display Range Over**

Meaning Though not an error, this is displayed when the process value exceeds the display range when the control range (setting range $\pm 10\%$) is larger than the display range (-1999 to 9999).
 • When less than “-1999” C C C C
 • When greater than “9999” 3 3 3 3
Operation Control continues, allowing normal operation.

Err Motor Calibration Error (Displayed on the No. 2 Display)

Meaning	Motor calibration has ended with an error.
Action	First, correctly connect the wiring for the potentiometer, open output, and close output. Execute the motor calibration again.
Operation Procedure	
Operation at Error	When motor calibration is executed, open output will operate and then close output will operate. However, as the value is incorrect, the result turns out to be an error.

■ Fuzzy Self-tuning

Fuzzy self-tuning is a function that enables the E5AK/E5EK to calculate the most suitable PID constants for the controlled object.

Features

- The E5AK/E5EK determines by itself when to perform fuzzy self-tuning.

Fuzzy Self-tuning Function

The fuzzy self-tuning function has three modes.

In SRT (step response tuning) mode, the PID constants are tuned using a step response method at the time the set point is changed.

In DT (disturbance tuning) mode, the PID constants are amended so that the controlled temperature will be within the target range set in advance when there is external disturbance.

In HT (hunting tuning) mode, when hunting occurs, the PID constants are amended to suppress the hunting.

Note: Be sure to turn on the power supply to the load either before or simultaneously with the start of Temperature Controller operation.

Dead time will be measured from the time the Temperature Controller starts operating. If a load such as a heater is turned on after the Temperature Controller is turned on, dead time longer than the actual value will be measured and inappropriate PID constants will be obtained. If an extremely large amount of dead time is measured, the control amount will be set to 0% for a short period of time before being returned to 100%, and the constants will then be retuned. Retuning is performed only for large amounts of dead time, so be sure to follow the precaution given above when starting operation.

Startup Conditions of SRT

SRT will start if the following conditions are satisfied simultaneously when the E5AK/E5EK is turned on or the set point is changed.

At the time the E5AK/E5EK starts operating	At the time set point is changed
<ol style="list-style-type: none"> 1. The set point at the time the E5AK/E5EK starts operating is different from the set point used at the time SRT was last executed (see note). 2. The process value at the time the E5AK/E5EK starts operating is smaller than the set point in reverse operation and larger than the set point in normal operation. 	<ol style="list-style-type: none"> 1. The new set point is different from the set point used at the time SRT was last executed (see note). 2. The process value is in stable condition before the set point is changed. 3. A larger set point value is set in reverse operation and a smaller set point is set in normal operation.

Note: The last SRT-executed set point is set to 0 before shipping and when changing from advanced PID control to advanced PID control with fuzzy self-tuning.

PID Constant Refreshing Conditions

If the step control amount is applied before the maximum temperature slope (R) is obtained, SRT will not renew any PID constant. If the proportional band obtained from the R and L values that were measured before the imposition had been completed is larger than the present proportional band, the PID constants will be renewed because the measured value is in the direction towards the suitable proportional band value, and the set point at that time will be the SRT-executed set point.

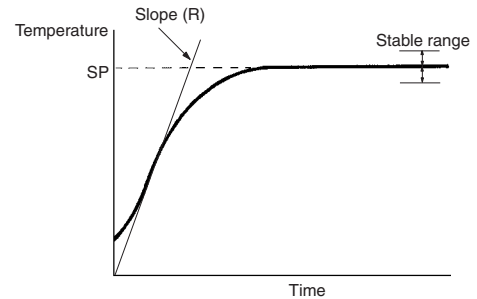

Stable Temperature Status

If the temperature is within the stable range for a certain time, it is deemed that the temperature is stable. This time is called stability judgement time. Like PID constants, stability judgement time is adjusted with fuzzy self-tuning according to the characteristics of the object to be controlled. Fuzzy self-tuning will not be activated if the temperature is stable because the Temperature Controller deems that temperature control is smooth.

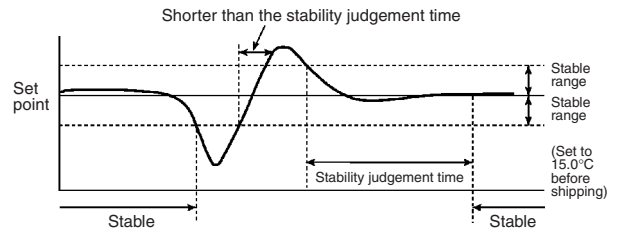

Balanced Status

If the process value is within the stable range for 60 s when there is no output, it is deemed that the temperature is balanced.

Startup Conditions of DT

1. DT will start if the temperature that has been stable varies due to external disturbance and the deflection of the temperature exceeds the stable range, and then the temperature becomes stable, provided that the number of maximum temperature values is less than four.
2. DT will start if the set point is changed under the condition that SRT does not start and the temperature becomes stable, provided that the number of maximum temperature values is less than four.
If there are four or more maximum temperature values, HT will start.

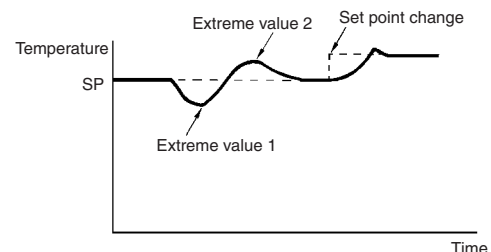

Startup Conditions of HT

HT will be ON when there is hunting with four or more maximum temperature values (extreme values) while SRT is not being executed.

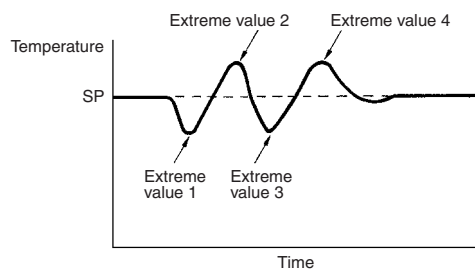

Note: In specific applications where temperature varies periodically due to disturbance, internal parameters need to be adjusted. For details, refer to the *E5AK/E5EK User's Manual (H83/H85)*.

Peripheral Devices

■ SSR

Connection Example of Digital Controller and SSR

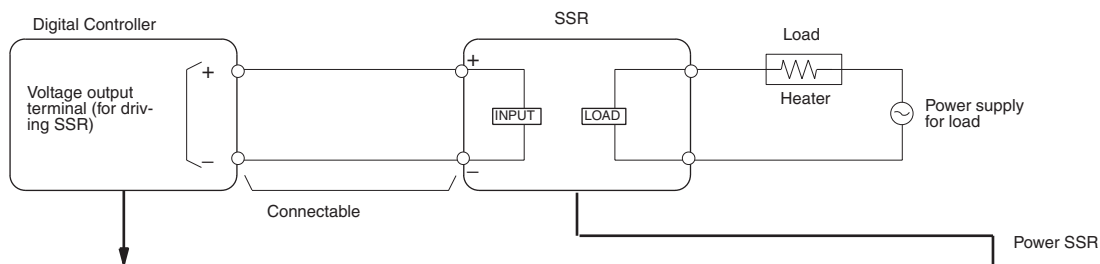

E5AK/E5EK

Digital Controller with Voltage Output (12 VDC, 40 mA max.)



E5CK

Digital Controller with Voltage Output (12 VDC, 20 mA max.)



See the following table.

Model	G3PA	G3NH	G3NA	G3NE	G3B
Appearance					
SSRs connected in parallel	E5AK/E5EK: 8 pcs. E5CK: 4 pcs.	E5AK/E5EK: 8 pcs. E5CK: 4 pcs.	E5AK/E5EK: 5 pcs. E5CK: 2 pcs.	E5AK/E5EK: 2 pcs. E5CK: 1 piece	E5AK/E5EK: 5 pcs. E5CK: 2 pcs.
Rated input voltage	5 to 24 VDC	5 to 24 VDC	5 to 24 VDC	12 VDC	5 to 24 VDC
Features	Thin, monoblock construction with heat sink	For high-power heater control	Standard model with screw terminals	Compact, low-cost model with tab terminals	Socket, model with 5-A switching capacity

Precautions

General Precautions

Operating Environment

Keep within the rated ambient operating temperature, ambient operating humidity, and storage temperature ranges.

Use the Unit according to the vibration resistance, shock resistance, and degree of protection.

Do not use the Unit in places with corrosive gas or excessive dust.

Do not use the Unit nearby machines generating high-frequency noise.

Correct Use

Mounting

The dimensions of the Digital Controller conform to DIN 43700.

Recommended panel thickness is 1 to 8 mm.

Mount the Unit horizontally.

Connection

To reduce inductive noise influence, the lead wires connecting the input type to the Digital Controller must be separated from the power lines and load lines.

Use the specified compensating conductors for thermocouples. Use lead wires having a small resistance for platinum resistance thermometers.

Connection Example

Wire the terminals of the Unit using solderless terminals.

The tightening torque applied to the terminal screws of the Unit must be approximately 0.78 N·m or 8 kgf·cm.

Use the following type of solderless terminals for M3.5 screws.

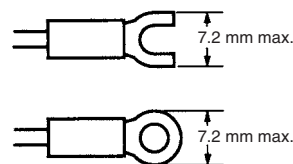

Operation

The alarm outputs of a model with an alarm function may not turn ON properly when the model malfunctions. The use of alarm equipment with the model is recommended.

The parameters and internal switch are set before shipping so that the Unit will function normally. Change the settings of the parameters and internal switch according to the application if necessary.

Several seconds are required until the relay is turned ON after power has been supplied to the Digital Controller. Therefore, take this time delay into consideration when designing sequenced circuits which incorporate a Digital Controller.

Do not use excessive force when drawing out the internal mechanism from the housing. Protect the internal connector or electronic parts of the Unit from shock. Protect against static discharge when changing the settings of the internal switch. Changing the settings on a grounded conductive mat is recommended.

When connecting the Control Output Unit to the Temperature Controller or Digital Controller, make sure that the Control Output Unit is a suitable type. The use of an improper type of Control Output Unit may cause the system to malfunction.

The heater burnout alarm will not be available if the Linear Output Unit is used.

■ Period and Scope of Guarantee

Unit with Standard Specifications

Scope of Guarantee

Should the Unit malfunction during the guarantee period, OMRON shall repair the Unit or replace any parts of the Unit at the expense of OMRON.

The above does not apply in the following cases.

1. Any malfunction of the Unit due to the incorrect use or improper handling of the Unit.
2. Any malfunction of the Unit not originating from the Unit.
3. Any malfunction of the Unit due to a modification of the Unit or repairs to the Unit carried out by any person not authorized by OMRON.
4. Any malfunction of the Unit due to any natural disaster.

OMRON shall not be responsible for any damage or loss induced by any malfunction of the Unit.

Three-year Guarantee

Period of Guarantee

The guarantee period of the Unit is three years starting from the date the Unit is shipped from the factory.

Scope of Guarantee

The Unit is guaranteed under the following operating conditions.

1. Average Operating Temperature (see note): -10°C to 50°C
2. Mounting Method: Standard mounting

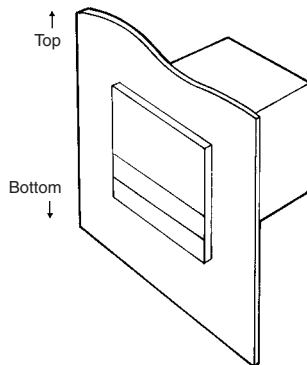

Note: Average Operating Temperature

Refer to the process temperature of the Unit mounted to a control panel and connected to peripheral devices on condition that the Unit is in stable operation, sensor input type K is selected for the Unit, the positive and negative thermocouple input terminals of the Unit are short-circuited, and the ambient temperature is stable.

Should the Unit malfunction during the guarantee period, OMRON shall repair the Unit or replace any parts of the Unit at the expense of OMRON.

The above does not apply in the following cases.

1. Any malfunction of the Unit due to the incorrect use or improper handling of the Unit.
2. Any malfunction of the Unit not originating from the Unit.
3. Any malfunction of the Unit due to a modification of the Unit or repairs to the Unit carried out by any person not authorized by OMRON.
4. Any malfunction of the Unit due to any natural disaster.

OMRON shall not be responsible for any damage or loss induced by any malfunction of the Unit.

Warranty and Application Considerations

Read and Understand This Catalog

Please read and understand this catalog before purchasing the products. Please consult your OMRON representative if you have any questions or comments.

Warranty and Limitations of Liability

WARRANTY

OMRON's exclusive warranty is that the products are free from defects in materials and workmanship for a period of one year (or other period if specified) from date of sale by OMRON.

OMRON MAKES NO WARRANTY OR REPRESENTATION, EXPRESS OR IMPLIED, REGARDING NON-INFRINGEMENT, MERCHANTABILITY, OR FITNESS FOR PARTICULAR PURPOSE OF THE PRODUCTS. ANY BUYER OR USER ACKNOWLEDGES THAT THE BUYER OR USER ALONE HAS DETERMINED THAT THE PRODUCTS WILL SUITABLY MEET THE REQUIREMENTS OF THEIR INTENDED USE. OMRON DISCLAIMS ALL OTHER WARRANTIES, EXPRESS OR IMPLIED.

LIMITATIONS OF LIABILITY

OMRON SHALL NOT BE RESPONSIBLE FOR SPECIAL, INDIRECT, OR CONSEQUENTIAL DAMAGES, LOSS OF PROFITS, OR COMMERCIAL LOSS IN ANY WAY CONNECTED WITH THE PRODUCTS, WHETHER SUCH CLAIM IS BASED ON CONTRACT, WARRANTY, NEGLIGENCE, OR STRICT LIABILITY.

In no event shall the responsibility of OMRON for any act exceed the individual price of the product on which liability is asserted.

IN NO EVENT SHALL OMRON BE RESPONSIBLE FOR WARRANTY, REPAIR, OR OTHER CLAIMS REGARDING THE PRODUCTS UNLESS OMRON'S ANALYSIS CONFIRMS THAT THE PRODUCTS WERE PROPERLY HANDLED, STORED, INSTALLED, AND MAINTAINED AND NOT SUBJECT TO CONTAMINATION, ABUSE, MISUSE, OR INAPPROPRIATE MODIFICATION OR REPAIR.

Application Considerations

SUITABILITY FOR USE

OMRON shall not be responsible for conformity with any standards, codes, or regulations that apply to the combination of products in the customer's application or use of the products.

Take all necessary steps to determine the suitability of the product for the systems, machines, and equipment with which it will be used.

Know and observe all prohibitions of use applicable to this product.

NEVER USE THE PRODUCTS FOR AN APPLICATION INVOLVING SERIOUS RISK TO LIFE OR PROPERTY WITHOUT ENSURING THAT THE SYSTEM AS A WHOLE HAS BEEN DESIGNED TO ADDRESS THE RISKS, AND THAT THE OMRON PRODUCTS ARE PROPERLY RATED AND INSTALLED FOR THE INTENDED USE WITHIN THE OVERALL EQUIPMENT OR SYSTEM.

Disclaimers

PERFORMANCE DATA

Performance data given in this catalog is provided as a guide for the user in determining suitability and does not constitute a warranty. It may represent the result of OMRON's test conditions, and the users must correlate it to actual application requirements. Actual performance is subject to the OMRON *Warranty and Limitations of Liability*.

CHANGE IN SPECIFICATIONS

Product specifications and accessories may be changed at any time based on improvements and other reasons. Consult with your OMRON representative at any time to confirm actual specifications of purchased product.

DIMENSIONS AND WEIGHTS

Dimensions and weights are nominal and are not to be used for manufacturing purposes, even when tolerances are shown.

ALL DIMENSIONS SHOWN ARE IN MILLIMETERS.

To convert millimeters into inches, multiply by 0.03937. To convert grams into ounces, multiply by 0.03527.

Cat. No. H084-E1-05 **In the interest of product improvement, specifications are subject to change without notice.**

OMRON Corporation

Industrial Automation Company

Control Devices Division H.Q.

Analog Controller Division

Shiokoji Horikawa, Shimogyo-ku,

Kyoto, 600-8530 Japan

Tel: (81)75-344-7080/Fax: (81)75-344-7189

Printed in Japan

1106-0.2M (9703) (M)



Компания «ЭлектроПласт» предлагает заключение долгосрочных отношений при поставках импортных электронных компонентов на взаимовыгодных условиях!

Наши преимущества:

- Оперативные поставки широкого спектра электронных компонентов отечественного и импортного производства напрямую от производителей и с крупнейших мировых складов;
- Поставка более 17-ти миллионов наименований электронных компонентов;
- Поставка сложных, дефицитных, либо снятых с производства позиций;
- Оперативные сроки поставки под заказ (от 5 рабочих дней);
- Экспресс доставка в любую точку России;
- Техническая поддержка проекта, помощь в подборе аналогов, поставка прототипов;
- Система менеджмента качества сертифицирована по Международному стандарту ISO 9001;
- Лицензия ФСБ на осуществление работ с использованием сведений, составляющих государственную тайну;
- Поставка специализированных компонентов (Xilinx, Altera, Analog Devices, Intersil, Interpoint, Microsemi, Aeroflex, Peregrine, Syfer, Eurofarad, Texas Instrument, Miteq, Cobham, E2V, MA-COM, Hittite, Mini-Circuits, General Dynamics и др.);

Помимо этого, одним из направлений компании «ЭлектроПласт» является направление «Источники питания». Мы предлагаем Вам помощь Конструкторского отдела:

- Подбор оптимального решения, техническое обоснование при выборе компонента;
- Подбор аналогов;
- Консультации по применению компонента;
- Поставка образцов и прототипов;
- Техническая поддержка проекта;
- Защита от снятия компонента с производства.



Как с нами связаться

Телефон: 8 (812) 309 58 32 (многоканальный)

Факс: 8 (812) 320-02-42

Электронная почта: org@eplast1.ru

Адрес: 198099, г. Санкт-Петербург, ул. Калинина, дом 2, корпус 4, литера А.