

600V ACTIVE OR'ING MOSFET CONTROLLER IN SO7

Description

The ZXGD3114N7 is a 600V active ORing MOSFET controller designed for driving a very-low $R_{DS(ON)}$ power MOSFET as an ideal diode. This replaces the standard rectifier to reduce the forward voltage drop and overall increase the power transfer efficiency.

The ZXGD3114N7 can be used on both high-side and low-side power supply units (PSU) with rails up to $\pm 600V$. It enables very-low $R_{DS(ON)}$ MOSFETs to operate as ideal diodes as the turn-off threshold is only -3mV with $\pm 2mV$ tolerance. In the typical 48V configuration, the standby power consumption is <50mW as the low quiescent supply current is <1mA. During PSU fault condition, the ORing controller detects the power reduction and rapidly turns off the MOSFET in <600ns to block reverse current flow and avoid the common bus voltage dropping.

Applications

Active ORing Controller in:

- (N + 1) Redundant Power Supplies
- Telecom and Networking
- Data Centers and Servers

Features

- Active ORing MOSFET Controller for High- or Low-Side PSU
- Ideal Diode to Reduce Forward Voltage Drop
- -3mV Typical Turn-Off Threshold with $\pm 2mV$ Tolerance
- 600V Drain Voltage Rating
- 25V V_{CC} Rating
- <50mW Standby Power with Quiescent Supply Current <1mA
- <600ns Turn-Off Time to Minimize Reverse Current
- **Totally Lead-Free & Fully RoHS Compliant (Notes 1 & 2)**
- **Halogen and Antimony Free. "Green" Device (Note 3)**

Mechanical Data

- Case: SO-7
- Case Material: Molded Plastic. "Green" Molding Compound. UL Flammability Rating 94V-0
- Moisture Sensitivity: Level 1 per J-STD-020
- Terminals: Finish—Matte Tin Plated Leads, Solderable per MIL-STD-202, Method 208 $\text{\textcircled{3}}$
- Weight: 0.074 grams (Approximate)

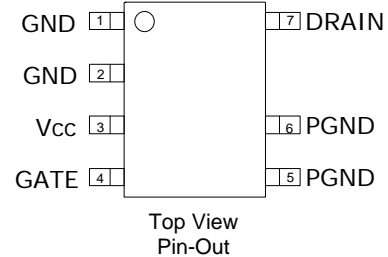
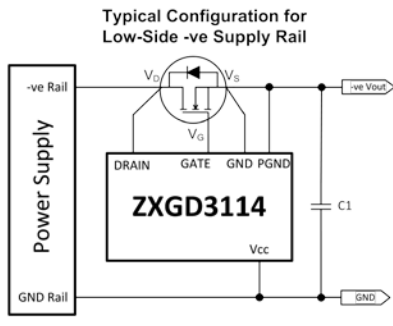

Ordering Information (Note 4)

Product	Marking	Reel Size (inches)	Tape Width (mm)	Quantity per Reel
ZXGD3114N7TC	ZXGD3114	13	12	2500

- Notes:
1. No purposely added lead. Fully EU Directive 2002/95/EC (RoHS), 2011/65/EU (RoHS 2) & 2015/863/EU (RoHS 3) compliant.
 2. See <https://www.diodes.com/quality/lead-free/> for more information about Diodes Incorporated's definitions of Halogen- and Antimony-free, "Green" and Lead-free.
 3. Halogen- and Antimony-free "Green" products are defined as those which contain <900ppm bromine, <900ppm chlorine (<1500ppm total Br + Cl) and <1000ppm antimony compounds.
 4. For packaging details, go to our website at <http://www.diodes.com/products/packages.html>.

Marking Information

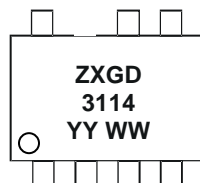

ZXGD = Product Type Marking Code, Line 1
3114 = Product Type Marking Code, Line 2
YY = Year (ex: 17 = 2017)
WW = Week (01 to 53)

Pin Functions

Pin Number	Pin Name	Pin Function and Description
1, 2	GND	Ground Connect this pin to the MOSFET source terminal and ground reference point.
3	V _{CC}	Power Supply This supply pin should be closely decoupled to ground with a X7R type capacitor.
4	GATE	Gate Drive This pin sources (I _{SOURCE}) and sinks (I _{SINK}) current into the MOSFET gate. If V _{CC} > 12V, then the GATE-to-GND will clamp at 12V. The turn on time of the MOSFET can be programmed through an external gate resistor (R _G).
5, 6	PGND	Power Ground Connect this pin to the MOSFET source terminal and ground reference point.
7	DRAIN	Drain Sense Connect this pin to the MOSFET drain terminal to detect the change in drain-source voltage.

Absolute Maximum Ratings (Voltage relative to GND, @ T_A = +25°C, unless otherwise specified.)

Characteristic	Symbol	Value	Unit
Supply Voltage	V _{CC}	25	V
Drain Pin Voltage	V _D	-3 to 600	V
Gate Output Voltage**	V _G	-3 to V _{CC} + 3	V
Gate Driver Peak Source Current	I _{SOURCE}	2	A
Gate Driver Peak Sink Current	I _{SINK}	5	A

**Gate voltage is clamped to 12V.

Thermal Characteristics

Characteristic	Symbol	Value	Unit	
Power Dissipation Linear Derating Factor	P _D	490	mW mW/°C	
		(Note 5)		3.92
		(Note 6)		655
		(Note 7)		5.24
		(Note 8)		720
Thermal Resistance, Junction to Ambient	R _{θJA}	785	°C/W	
		(Note 5)		6.28
		(Note 6)		255
		(Note 7)		191
(Note 8)	173			
(Note 9)	159			
Thermal Resistance, Junction to Lead	R _{θJL}	135	°C/W	
Operating and Storage Temperature Range	T _J , T _{STG}	-50 to +150	°C	

ESD Ratings (Note 10)

Characteristic	Symbol	Value	Unit	JEDEC Class
Electrostatic Discharge—Human Body Model	ESD HBM	2000	V	3A
Electrostatic Discharge—Machine Model	ESD MM	200	V	B

- Notes:
- For a device surface mounted on minimum recommended pad layout FR-4 PCB with high coverage of single sided 1oz copper, in still air conditions; the device is measured when operating in a steady-state condition.
 - Same as Note 5, except pin 3 (V_{CC}) and pins 5 & 6 (PGND) are both connected to separate 5mm × 5mm 1oz copper heat-sinks.
 - Same as Note 6, except both heat-sinks are 10mm × 10mm.
 - Same as Note 6, except both heat-sinks are 15mm × 15mm.
 - Thermal resistance from junction to solder-point at the end of each lead on pins 2 & 3 (GND) and pins 5 & 6 (V_{CC}).
 - Refer to JEDEC specification JESD22-A114 and JESD22-A115.

Thermal Derating Curve

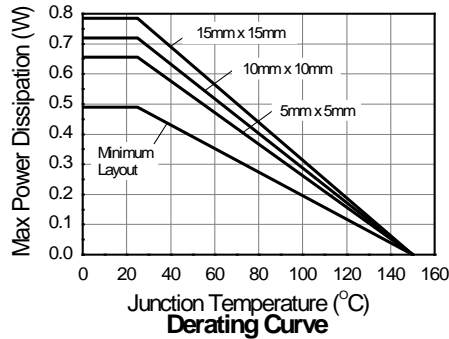

Electrical Characteristics (@ $V_{CC} = 12V$, $T_A = +25^\circ C$, unless otherwise specified.)

Characteristic	Symbol	Min	Typ	Max	Unit	Test Condition
Input Supply						
Operating Supply Voltage	V_{CC}	4	—	20	V	—
Quiescent Current	I_Q	—	260	400	μA	$-0.6V \leq V_{DRAIN} \leq 600V$
Drain Low Input Current	I_{DL}	-100	-15	—	nA	$V_D = -0.1V$
Drain High Input Current	I_{DH}	—	0.85	10	μA	$V_D = 600V$
Gate Driver						
Gate Peak Source Current	I_{SOURCE}	—	0.66	—	A	$C_L = 47nF$
Gate Peak Sink Current	I_{SINK}	—	3.3	—		
Gate Peak Source Current (Note 11)	I_{SOURCE}	1	—	—	A	$V_{GATE} = 5V$ & $V_{DRAIN} = -1V$
Gate Peak Sink Current (Note 11)	I_{SINK}	1.8	—	—	A	$V_{GATE} = 5V$ & $V_{DRAIN} = 1V$
Detector Under DC Condition						
Turn-Off Threshold Voltage	V_T	-5	-3	-1	mV	$V_G \leq 1V$
Gate Output Voltage	$V_{G(OFF)}$	—	0.1	0.3	V	$V_{DRAIN} \geq 0mV$ & $V_{CC} = 12V$
	V_G	10.5	10.85	—		$V_{DRAIN} = -8mV$ & $V_{CC} = 12V$
	$V_{G(OFF)}$	—	0.1	0.3		$V_{DRAIN} \geq 0mV$ & $V_{CC} = 4V$
	V_G	2.5	2.85	—		$V_{DRAIN} = -8mV$ & $V_{CC} = 4V$
	$V_{G(OFF)}$	—	0.1	0.3		$V_{DRAIN} \geq 0mV$ & $V_{CC} = 20V$
	V_G	10.5	11.2	—		$V_{DRAIN} = -8mV$ & $V_{CC} = 20V$
Switching Performance						
Turn-On Propagation Delay	$t_{D(RISE)}$	—	400	—	ns	$C_L = 47nF$ Rise and Fall Measured 10% to 90% Refer to Application Test Circuit Below
Gate Rise Time	t_R	—	695	—		
Turn-Off Propagation Delay	$t_{D(FALL)}$	—	400	—		
Gate Fall Time	t_F	—	131	—		

Note: 11. Measured under pulsed conditions. Pulse width = 300 μs . Duty cycle $\leq 2\%$.

Layout Considerations

The GATE pin should be close to the MOSFET gate to minimize trace resistance and inductance to maximize switching performance. While the V_{CC} to GND pin requires an X7R type capacitor closely decoupling the supply. Trace widths should be maximized in the high current paths through the MOSFET and ground return in order to minimize the effects of circuit resistance and inductance. Also, the ground return loop should be as short as possible. For thermal consideration, the main heat path is from pin 3 (V_{CC}) and pins 5 & 6 (PGND). For best thermal performance, the copper area connected to pin 3 (V_{CC}) and pins 5 & 6 (PGND) should be maximized.

Active ORing or (N+1) Redundancy Application

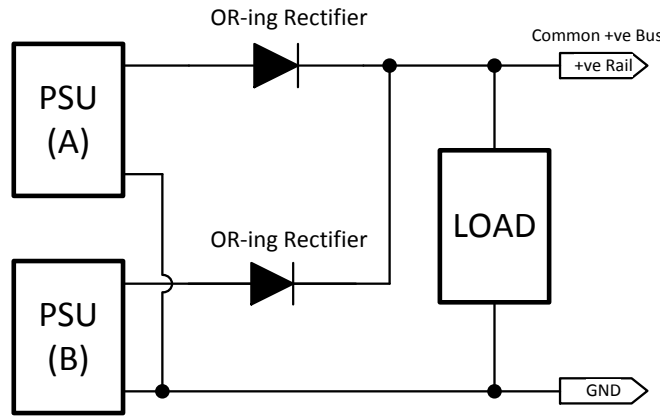

Figure 1

Critical systems require fault-tolerant power supplies that can be achieved by paralleling two or more PSUs into (N+1) redundancy configuration. During normal operation, usually all PSUs equally share the load for maximum reliability. If one of the PSU is unplugged or fails, the other PSUs fully support the load. To avoid the faulty PSU from affecting the common bus, an ORING rectifier blocks the reverse current flow into the faulty PSU. Likewise during hot-swapping, the ORING rectifiers isolate a PSU's discharged output capacitors from the common bus.

As the load current is in the tens of amps then a standard rectifier has a significant forward voltage drop. This both wastes power and significantly drops the potential on low voltage rails. Hence, very low $R_{DS(ON)}$ power MOSFETs can replace the standard rectifiers and the ZXGD3114 controls the MOSFET as an ideal diode.

Functional Block Diagram

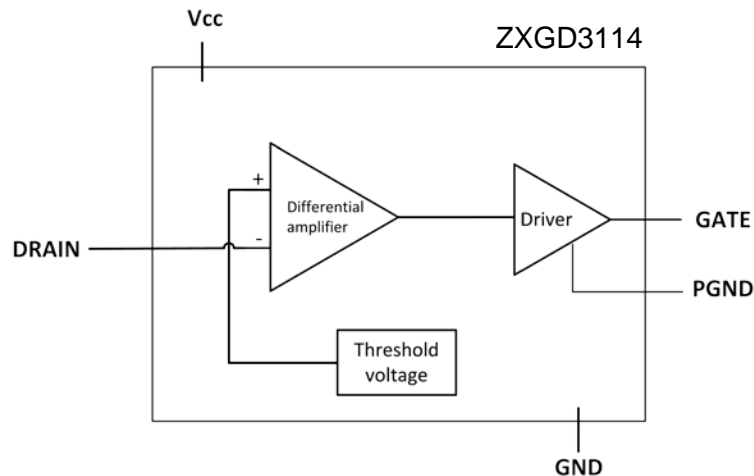

Figure 2

The device is comprised of a differential amplifier and high current driver. The differential amplifier acts as a detector and monitors the DRAIN-to-GND pin voltage difference. When this difference is less than the threshold voltage (V_T), a positive output voltage approaching V_{CC} is given on the GATE pin. If $V_{CC} > 12V$, the GATE-to-GND clamps at 12V. Conversely, when the DRAIN-to-GND pin voltage difference is greater than V_T , the GATE pin voltage rapidly reduces towards the GND voltage.

Typical Application Circuits

The focus application of the ZXGD3114 ORing controller is for the redundant low-side -400V power supply rail. HV to 12V regulator or a potential divider is recommended to power the V_{CC} of ZXGD3114 from high-voltage lines (see Figure 3).

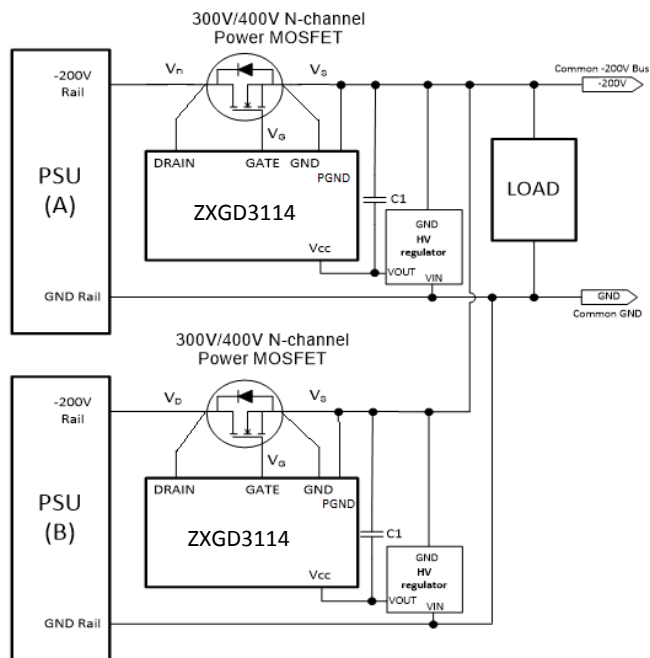
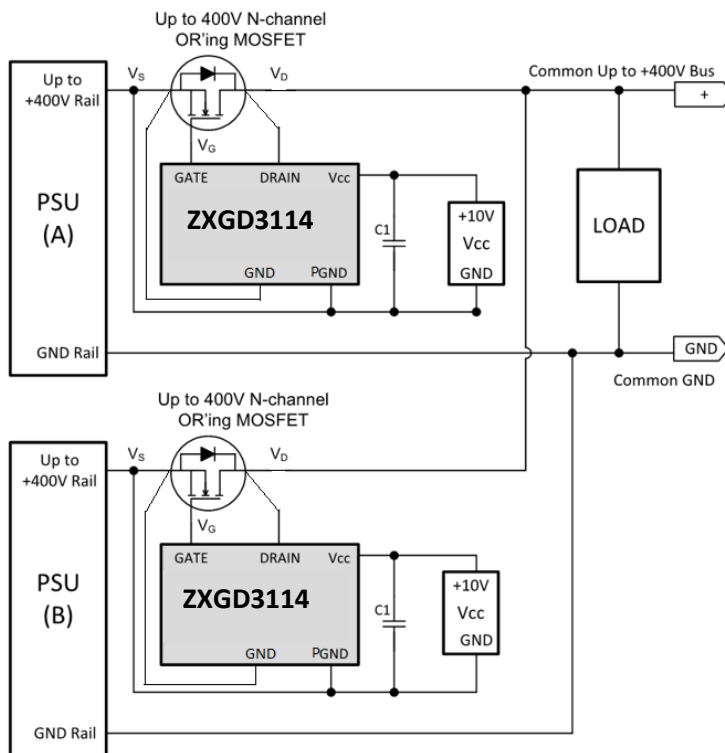

Figure 3

Figure 4 is an example of the ZXGD3114 ORing controller in a redundant high-side +400V power supply rail using an additional V_{CC} supply.



Operation in Typical Application

The ZXGD3114 operation is described step-by-step with reference to the typical application circuits and the timing diagram below:

1. The ZXGD3114 differential amplifier monitors the MOSFET's drain-source voltage (V_{DS}).
2. At system start up, the MOSFET body diode is forced to conduct current from the input PSU to the load, and V_{DS} is approximately $-0.6V$ as measured by the differential amplifier between DRAIN-to-GND pins.
3. $V_{DS} < V_T$ (threshold voltage), the differential amplifier, outputs a positive voltage approaching V_{CC} with respect to GND. This feeds the driver stage where the GATE pin voltage rises towards V_{CC} . If $V_{CC} > 12V$, then the GATE-to-GND clamps at $12V$.
4. The sourcing current out of the GATE pin drives the MOSFET gate to enhance the channel and turns it on.
5. If a short condition occurs on the input PSU, it causes the MOSFET V_{DS} to increase.
6. When $V_{DS} > V_T$, the differential amplifier's output goes to GND, and the driver stage rapidly pulls the GATE pin voltage to GND turning off the MOSFET channel. This prevents high reverse current flow from the load to the PSU, which could pull down the common bus voltage causing catastrophic system failure.

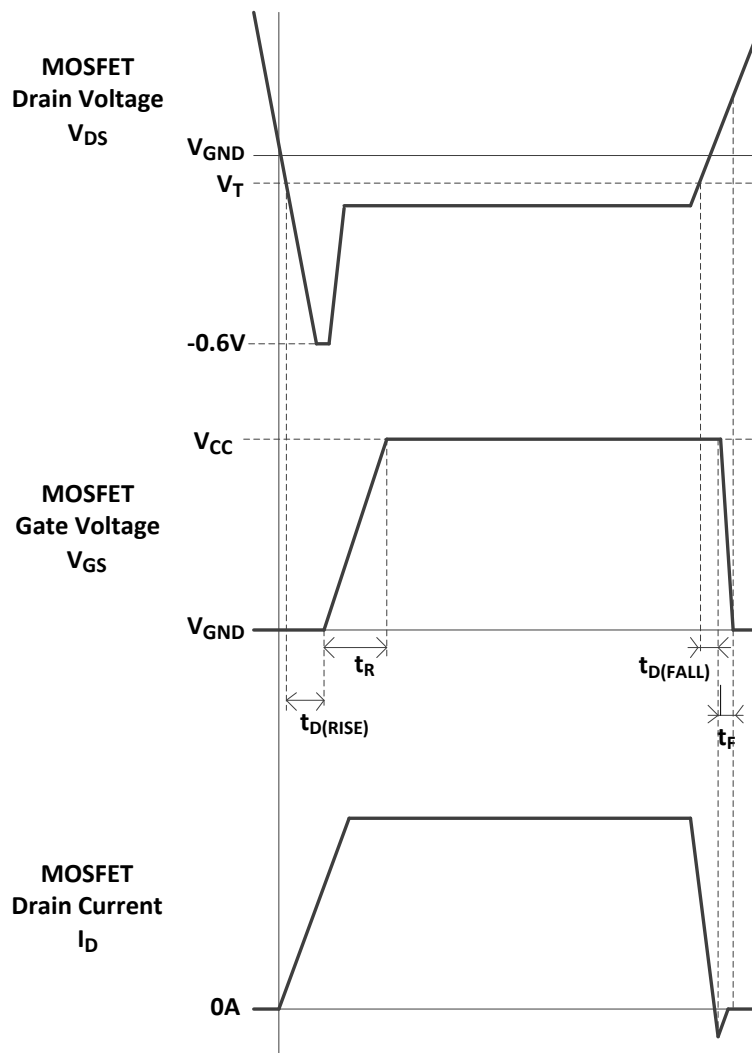

Typical Electrical Characteristics

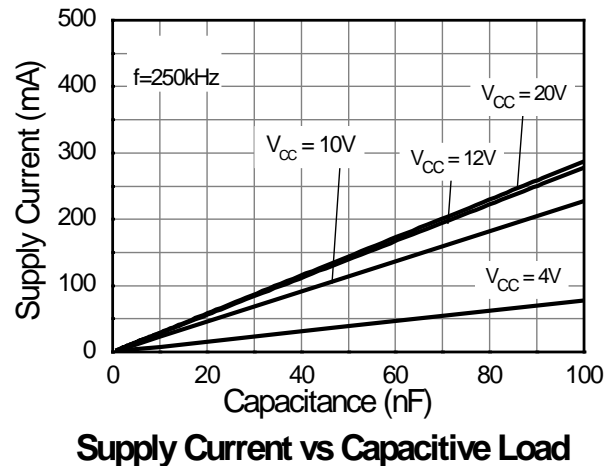
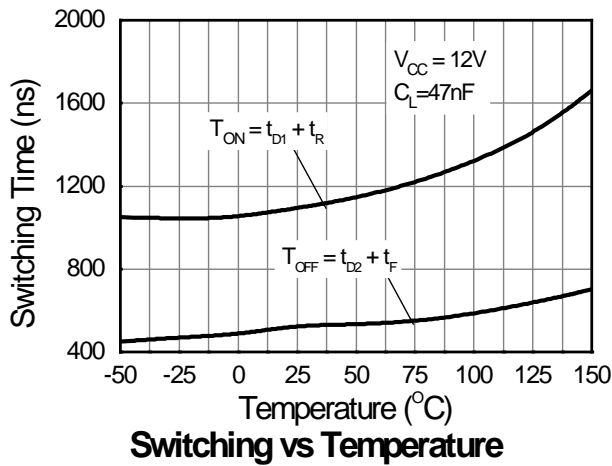
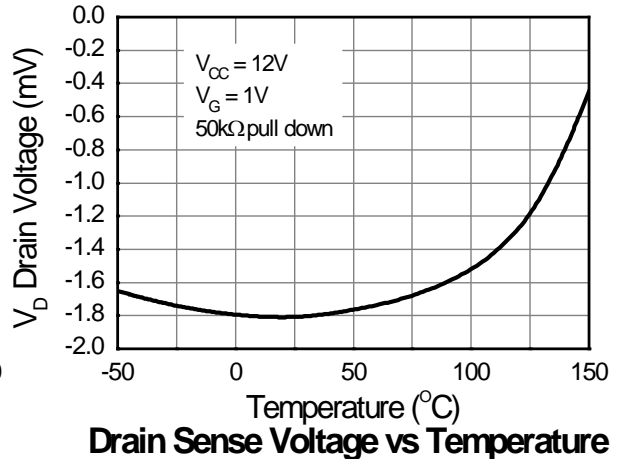
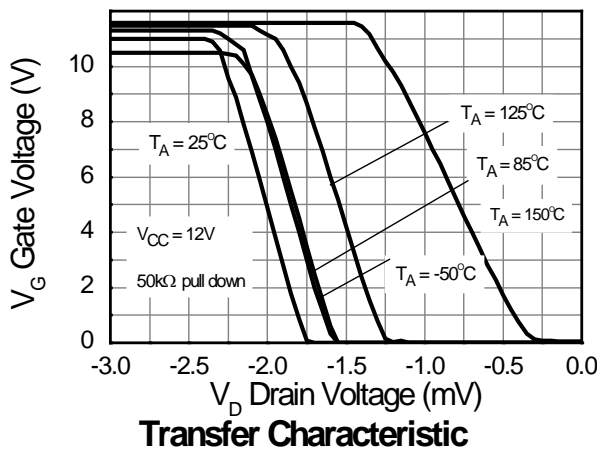
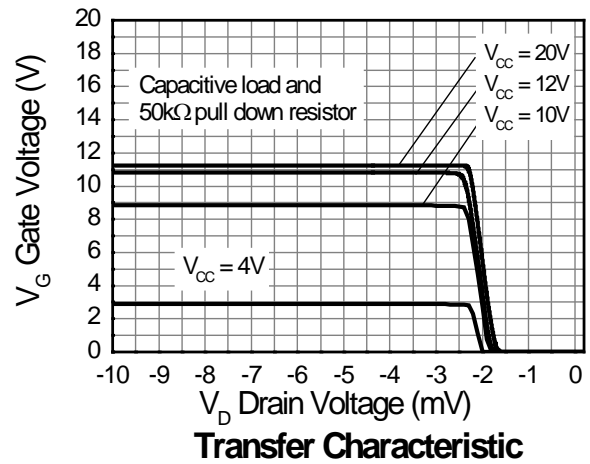
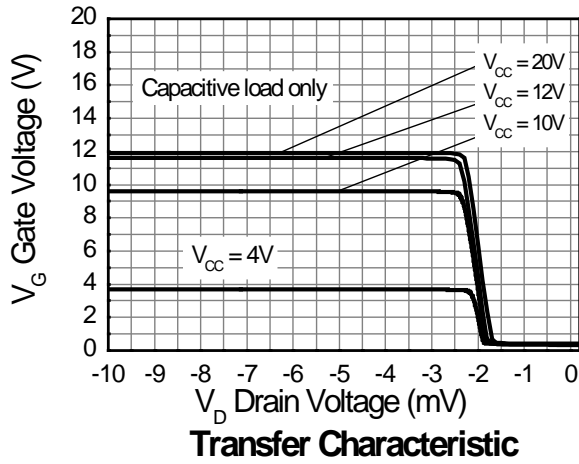

Typical Electrical Characteristics (continued)

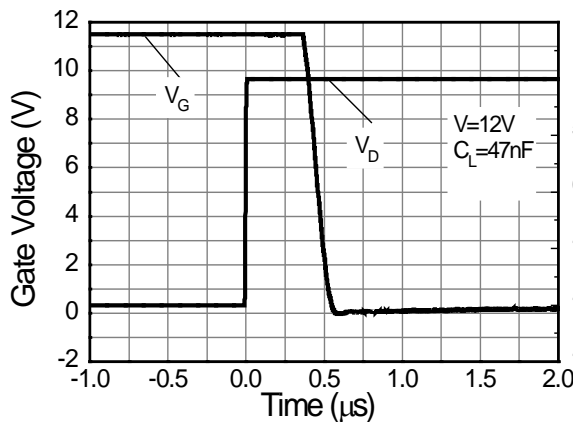

Switch Off Speed

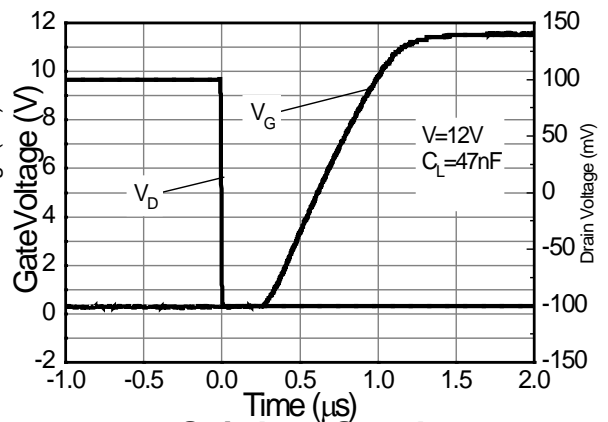

Switch On Speed

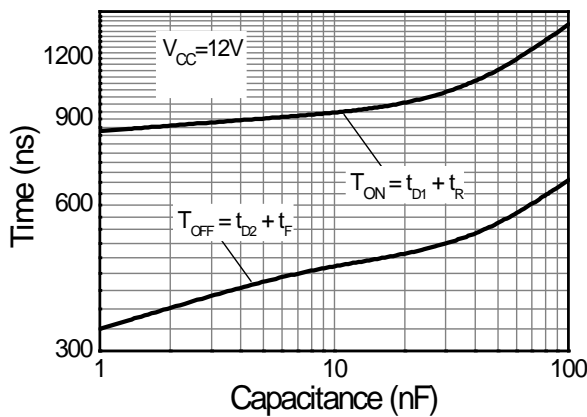

Switching vs Capacitive Load

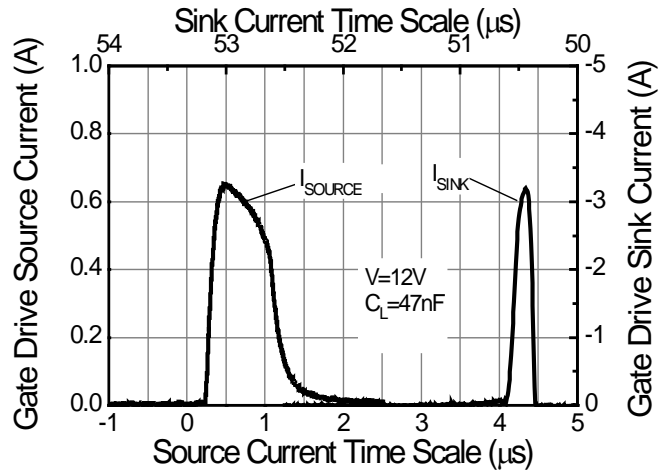

Gate Drive Current

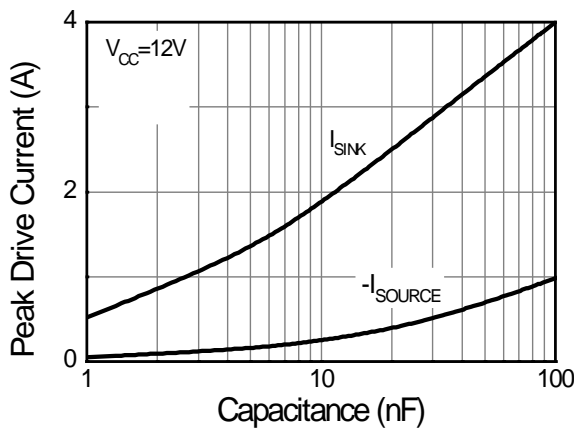

Gate Current vs Capacitive Load

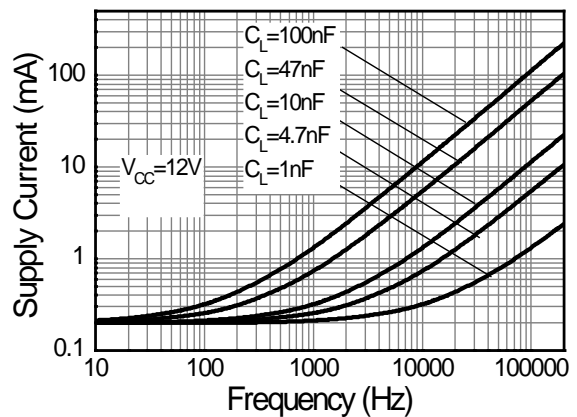

Supply Current vs Frequency

Package Outline Dimensions

Please see <http://www.diodes.com/package-outlines.html> for the latest version.

SO-7

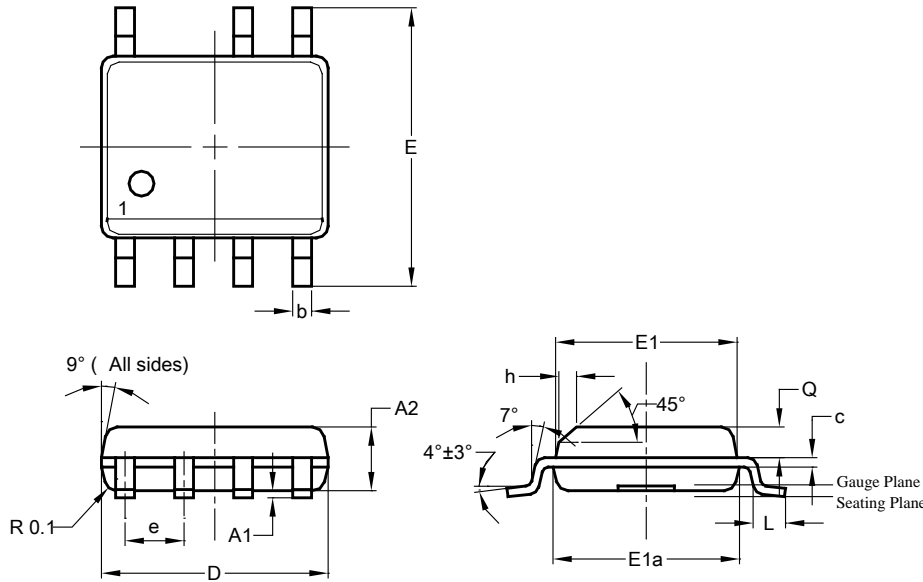

SO-7			
Dim	Min	Max	Typ
A2	1.40	1.50	1.45
A1	0.10	0.20	0.15
b	0.30	0.50	0.40
c	0.15	0.25	0.20
D	4.85	4.95	4.90
E	5.90	6.10	6.00
E1	3.80	3.90	3.85
E1a	3.85	3.95	3.90
e	—	—	1.27
h	—	—	0.35
L	0.62	0.82	0.72
Q	0.60	0.70	0.65
All Dimensions in mm			

Suggested Pad Layout

Please see <http://www.diodes.com/package-outlines.html> for the latest version.

SO-7

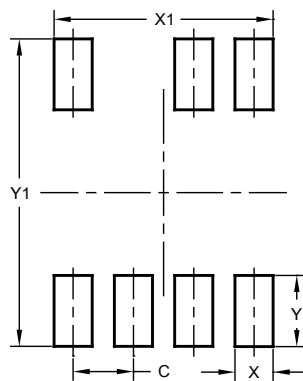

Dimensions	Value (in mm)
C	1.270
X	0.802
X1	4.612
Y	1.505
Y1	6.500

IMPORTANT NOTICE

DIODES INCORPORATED MAKES NO WARRANTY OF ANY KIND, EXPRESS OR IMPLIED, WITH REGARDS TO THIS DOCUMENT, INCLUDING, BUT NOT LIMITED TO, THE IMPLIED WARRANTIES OF MERCHANTABILITY AND FITNESS FOR A PARTICULAR PURPOSE (AND THEIR EQUIVALENTS UNDER THE LAWS OF ANY JURISDICTION).

Diodes Incorporated and its subsidiaries reserve the right to make modifications, enhancements, improvements, corrections or other changes without further notice to this document and any product described herein. Diodes Incorporated does not assume any liability arising out of the application or use of this document or any product described herein; neither does Diodes Incorporated convey any license under its patent or trademark rights, nor the rights of others. Any Customer or user of this document or products described herein in such applications shall assume all risks of such use and will agree to hold Diodes Incorporated and all the companies whose products are represented on Diodes Incorporated website, harmless against all damages.

Diodes Incorporated does not warrant or accept any liability whatsoever in respect of any products purchased through unauthorized sales channel. Should Customers purchase or use Diodes Incorporated products for any unintended or unauthorized application, Customers shall indemnify and hold Diodes Incorporated and its representatives harmless against all claims, damages, expenses, and attorney fees arising out of, directly or indirectly, any claim of personal injury or death associated with such unintended or unauthorized application.

Products described herein may be covered by one or more United States, international or foreign patents pending. Product names and markings noted herein may also be covered by one or more United States, international or foreign trademarks.

This document is written in English but may be translated into multiple languages for reference. Only the English version of this document is the final and determinative format released by Diodes Incorporated.

LIFE SUPPORT

Diodes Incorporated products are specifically not authorized for use as critical components in life support devices or systems without the express written approval of the Chief Executive Officer of Diodes Incorporated. As used herein:

A. Life support devices or systems are devices or systems which:

1. are intended to implant into the body, or
2. support or sustain life and whose failure to perform when properly used in accordance with instructions for use provided in the labeling can be reasonably expected to result in significant injury to the user.

B. A critical component is any component in a life support device or system whose failure to perform can be reasonably expected to cause the failure of the life support device or to affect its safety or effectiveness.

Customers represent that they have all necessary expertise in the safety and regulatory ramifications of their life support devices or systems, and acknowledge and agree that they are solely responsible for all legal, regulatory and safety-related requirements concerning their products and any use of Diodes Incorporated products in such safety-critical, life support devices or systems, notwithstanding any devices- or systems-related information or support that may be provided by Diodes Incorporated. Further, Customers must fully indemnify Diodes Incorporated and its representatives against any damages arising out of the use of Diodes Incorporated products in such safety-critical, life support devices or systems.

Copyright © 2018, Diodes Incorporated

www.diodes.com



Компания «ЭлектроПласт» предлагает заключение долгосрочных отношений при поставках импортных электронных компонентов на взаимовыгодных условиях!

Наши преимущества:

- Оперативные поставки широкого спектра электронных компонентов отечественного и импортного производства напрямую от производителей и с крупнейших мировых складов;
- Поставка более 17-ти миллионов наименований электронных компонентов;
- Поставка сложных, дефицитных, либо снятых с производства позиций;
- Оперативные сроки поставки под заказ (от 5 рабочих дней);
- Экспресс доставка в любую точку России;
- Техническая поддержка проекта, помощь в подборе аналогов, поставка прототипов;
- Система менеджмента качества сертифицирована по Международному стандарту ISO 9001;
- Лицензия ФСБ на осуществление работ с использованием сведений, составляющих государственную тайну;
- Поставка специализированных компонентов (Xilinx, Altera, Analog Devices, Intersil, Interpoint, Microsemi, Aeroflex, Peregrine, Syfer, Eurofarad, Texas Instrument, Miteq, Cobham, E2V, MA-COM, Hittite, Mini-Circuits, General Dynamics и др.);

Помимо этого, одним из направлений компании «ЭлектроПласт» является направление «Источники питания». Мы предлагаем Вам помощь Конструкторского отдела:

- Подбор оптимального решения, техническое обоснование при выборе компонента;
- Подбор аналогов;
- Консультации по применению компонента;
- Поставка образцов и прототипов;
- Техническая поддержка проекта;
- Защита от снятия компонента с производства.



Как с нами связаться

Телефон: 8 (812) 309 58 32 (многоканальный)

Факс: 8 (812) 320-02-42

Электронная почта: org@eplast1.ru

Адрес: 198099, г. Санкт-Петербург, ул. Калинина, дом 2, корпус 4, литера А.