

DESCRIPTION

The PUP270 series of AC/DC switching power supplies are for 240-270 watts of continuous output power. They are enclosed in a 94V-0 rated plastic cases an IEC320/C14 inlet to mate with interchangeable cord for world-wide use. All models meet EN 55022, EN55024 and FCC class B emission limits, and comply with UL, CSA, IEC and CE requirements.

FEATURES

- No load power consumption less than 0.15W
- Compliant with DoE level VI / CoC EPS V5 tier 2 requirements
- Meet energy star EPS2.0 /ErP lot 7
- With PFC circuit
- Operating altitude up to 5000 meters
- Wide input range 90 to 264 VAC
- 100% burn-in
- Overvoltage protection (latch)
- Overcurrent protection
- Over temperature protection (latch)
- Compliant with RoHS requirements

INPUT SPECIFICATIONS

Input voltage:	90-264 VAC
Input frequency:	47-63 Hz
Input current:	3.0 A (rms) for 115 VAC 1.5 A (rms) for 230 VAC
Earth leakage current:	3.5 mA max. @ 264 VAC, 63 Hz
Touch current:	100 µA max. @ 264 VAC, 63 Hz

OUTPUT SPECIFICATIONS

Output voltage /current:	See rating chart.
Maximum output power:	See rating chart.
Ripple and noise:	See rating chart.
Overvoltage protection:	Provided and set at 110-140% of its nominal output voltage
Overcurrent protection:	Protected to short circuit conditions
Temperature coefficient:	±0.04% /°C maximum
Transient response:	Maximum excursion of 4% or better on all models, recovering to 1% of final value within 500 us after a 25% step load change

ENVIRONMENTAL SPECIFICATIONS

Operating temperature:	0°C to +60°C
Storage temperature:	-20°C to +80°C
Relative humidity:	10% to 90% non-condensing
Temperature derating:	Derate from 100% at +40°C linearly to 50% at +60°C

PUP270 SERIES



RoHS



SAFETY STANDARD APPROVALS



UL 60950 3 rd, CSA C22.2 NO. 60950 3 rd
File No. E190414

TÜV EN 60950-1

GENERAL SPECIFICATIONS

Power factor:	0.98 Typical at 115 VAC
Efficiency:	89% min. at full load
Hold-up time:	10 ms minimum at 100 VAC
Line regulation:	±0.5% maximum at full load
Inrush current:	90 A @ 115 VAC or 180 A @ 230 VAC, at 25°C cold start
Withstand voltage:	1500 VAC from input to output
MTBF:	300,000 hours at full load at 25°C ambient , calculated per SR332

EMC Performance

EN55022:	Class B conducted, class B radiated
FCC:	Class B conducted, class B radiated
VCCI:	Class B conducted, class B radiated
EN61000-3-2:	Harmonic distortion, Class D
EN61000-3-3:	Line flicker
EN55024:	
EN61000-4-2:	ESD, ±15 KV air and ±8 KV contact
EN61000-4-3:	Radiated immunity, 3 V/m
EN61000-4-4:	Fast transient/burst, ±1 KV
EN61000-4-5:	Surge, ±1 KV diff., ±2 KV com.
EN61000-4-6:	Conducted immunity, 3 Vrms
EN61000-4-8:	Magnetic field immunity, 1 A/m
EN61000-4-11:	Voltage dip immunity, 30% reduction for 500 ms, and >95% reduction for 10 ms

OUTPUT VOLTAGE/CURRENT RATING CHART

Model	Output						Average Active Efficiency (typical) @ 115 / 230 Vac
	V1	Min. Current	Max. Current	Tol.	Ripple & Noise ⁽¹⁾	Max. Power	
PUP270-12-S	12 V	0 A	20.00 A	±5%	240 mV	240 W	89 /89%
PUP270-13-2-S	19 V	0 A	14.21 A	±5%	300 mV	270 W	89 /89%
PUP270-14-S	24 V	0 A	11.25A	±5%	300 mV	270 W	89 /89%
PUP270-18-S	48 V	0 A	5.62 A	±5%	500 mV	270 W	89 /89%
PUP270-19-S	54 V	0 A	5.00 A	±5%	550 mV	270 W	89 /89%

NOTES:

1. Ripple and noise is maximum peak to peak voltage value measured at output within 20 MHz bandwidth, at rated line voltage and output load ranges, and with a 47 µF electrolytic capacitor in parallel with a 0.1 µF ceramic capacitor across the output.

MECHANICAL SPECIFICATIONS

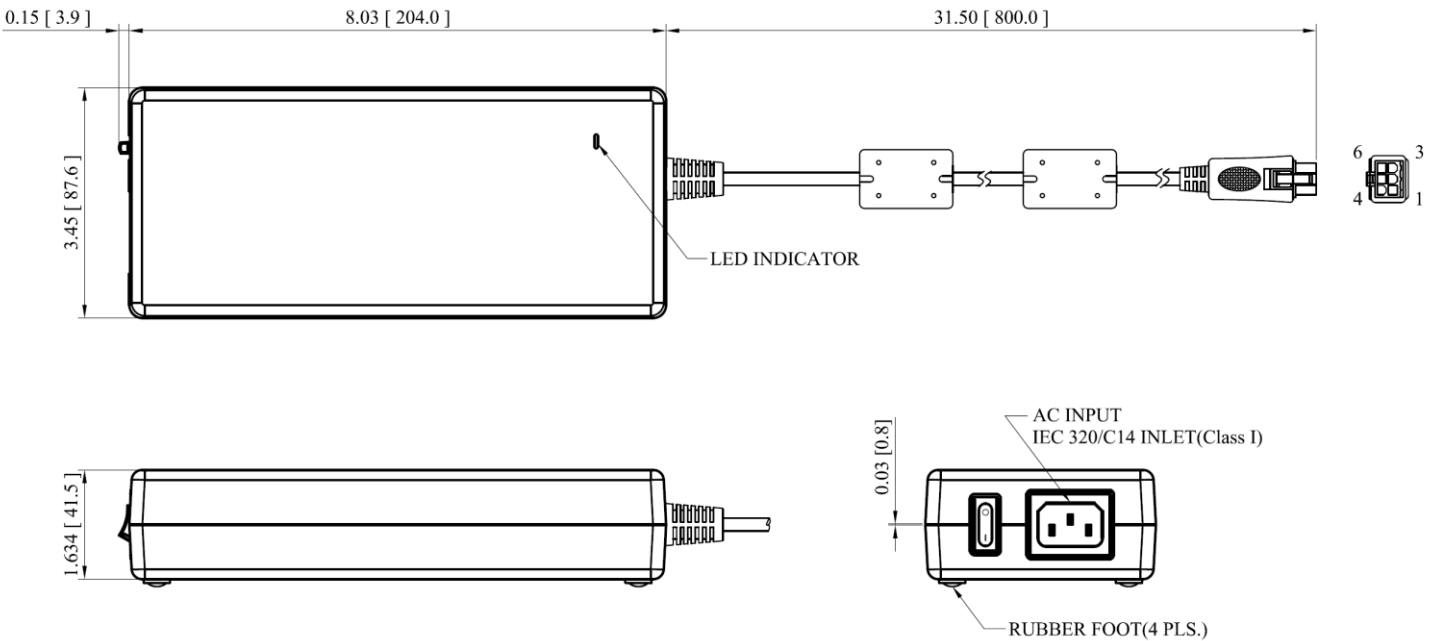

NOTES:

1. Dimensions shown in inches [mm]
2. Tolerance 0.02 [0.5] maximum
3. Weight: 1100 grams (2.425 lbs.) approx.
4. Output connector is JWT Mini - Fit receptacle, P/N: C4202H00-2x3P with female terminal C4202T2*-2 or equivalent, mating with JWT socket C4201H0*-2x3P and male terminal C4201T2*-2 or equivalent. It also mates with JWT headers C4201WR*-2x3P, C4201WV*-2x3P, or equivalent.
5. V1 return (-) is electrical connected to incoming Earth Ground through two 1.2K ohm resistors as standard.

OUTPUT POWER DERATING CURVE

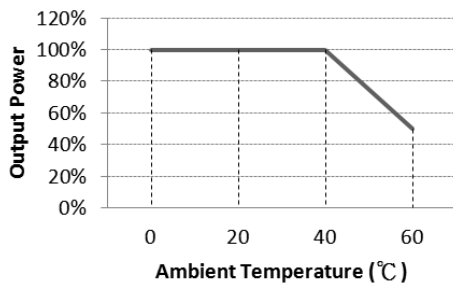

PIN CHART

PIN	1	2	3	4	5	6
	+V1	+V1	+V1	V1 Return	V1 Return	V1 Return



Компания «ЭлектроПласт» предлагает заключение долгосрочных отношений при поставках импортных электронных компонентов на взаимовыгодных условиях!

Наши преимущества:

- Оперативные поставки широкого спектра электронных компонентов отечественного и импортного производства напрямую от производителей и с крупнейших мировых складов;
- Поставка более 17-ти миллионов наименований электронных компонентов;
- Поставка сложных, дефицитных, либо снятых с производства позиций;
- Оперативные сроки поставки под заказ (от 5 рабочих дней);
- Экспресс доставка в любую точку России;
- Техническая поддержка проекта, помощь в подборе аналогов, поставка прототипов;
- Система менеджмента качества сертифицирована по Международному стандарту ISO 9001;
- Лицензия ФСБ на осуществление работ с использованием сведений, составляющих государственную тайну;
- Поставка специализированных компонентов (Xilinx, Altera, Analog Devices, Intersil, Interpoint, Microsemi, Aeroflex, Peregrine, Syfer, Eurofarad, Texas Instrument, Miteq, Cobham, E2V, MA-COM, Hittite, Mini-Circuits, General Dynamics и др.);

Помимо этого, одним из направлений компании «ЭлектроПласт» является направление «Источники питания». Мы предлагаем Вам помощь Конструкторского отдела:

- Подбор оптимального решения, техническое обоснование при выборе компонента;
- Подбор аналогов;
- Консультации по применению компонента;
- Поставка образцов и прототипов;
- Техническая поддержка проекта;
- Защита от снятия компонента с производства.



Как с нами связаться

Телефон: 8 (812) 309 58 32 (многоканальный)

Факс: 8 (812) 320-02-42

Электронная почта: org@eplast1.ru

Адрес: 198099, г. Санкт-Петербург, ул. Калинина, дом 2, корпус 4, литера А.