

This IC is a 2-wire serial E<sup>2</sup>PROM for DIMM Serial Presence Detect which operates with low current consumption and the wide range operation. This IC has the capacity of 2 K-bit and the organization of 256 words × 8-bit. Page write and sequential read are available.

This IC has hardware write protect and software write protect. Hardware write protect inhibits write to all memory area when connecting the WP pin to V<sub>CC</sub>. Software write protect inhibits write in 50% of the lower address (address 00h to 7Fh) in all memory area by inputting command when the WP pin is left open or connected to the GND pin.

**Caution** This product is intended to use in general electronic devices such as consumer electronics, office equipment, and communications devices. Before using the product in medical equipment or automobile equipment including car audio, keyless entry and engine control unit, contact to ABLIC Inc. is indispensable.

## ■ Features

- Operation voltage range
  - Read: 1.7 V to 5.5 V
  - Write: 1.7 V to 5.5 V
- Operation frequency:
  - 400 kHz max. (V<sub>CC</sub> = 1.7 V to 5.5 V)
- Write time: 5.0 ms max.
- Page write: 16 bytes / page
- Sequential read
- Noise suppression:
  - Schmitt trigger and noise filter on input pins (SCL, SDA)
- Write protect function during low power supply voltage
- Endurance: 10<sup>6</sup> cycle / word\*1 (Ta = +25°C)
- Data retention: 100 years (Ta = +25°C)
- Memory capacity: 2 K-bit
- Initial delivery state: FFh
- Operation temperature range: Ta = -40°C to +85°C
- Write protect:
  - Hardware protect 100%  
(addresses 00h to FFh)
  - Software protect for the lower address of 50%  
(addresses 00h to 7Fh)
- Lead-free (Sn 100%), halogen-free

\*1. For each address (Word: 8-bit)

## ■ Package

- DFN-8(2030)

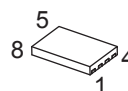

■ Block Diagram

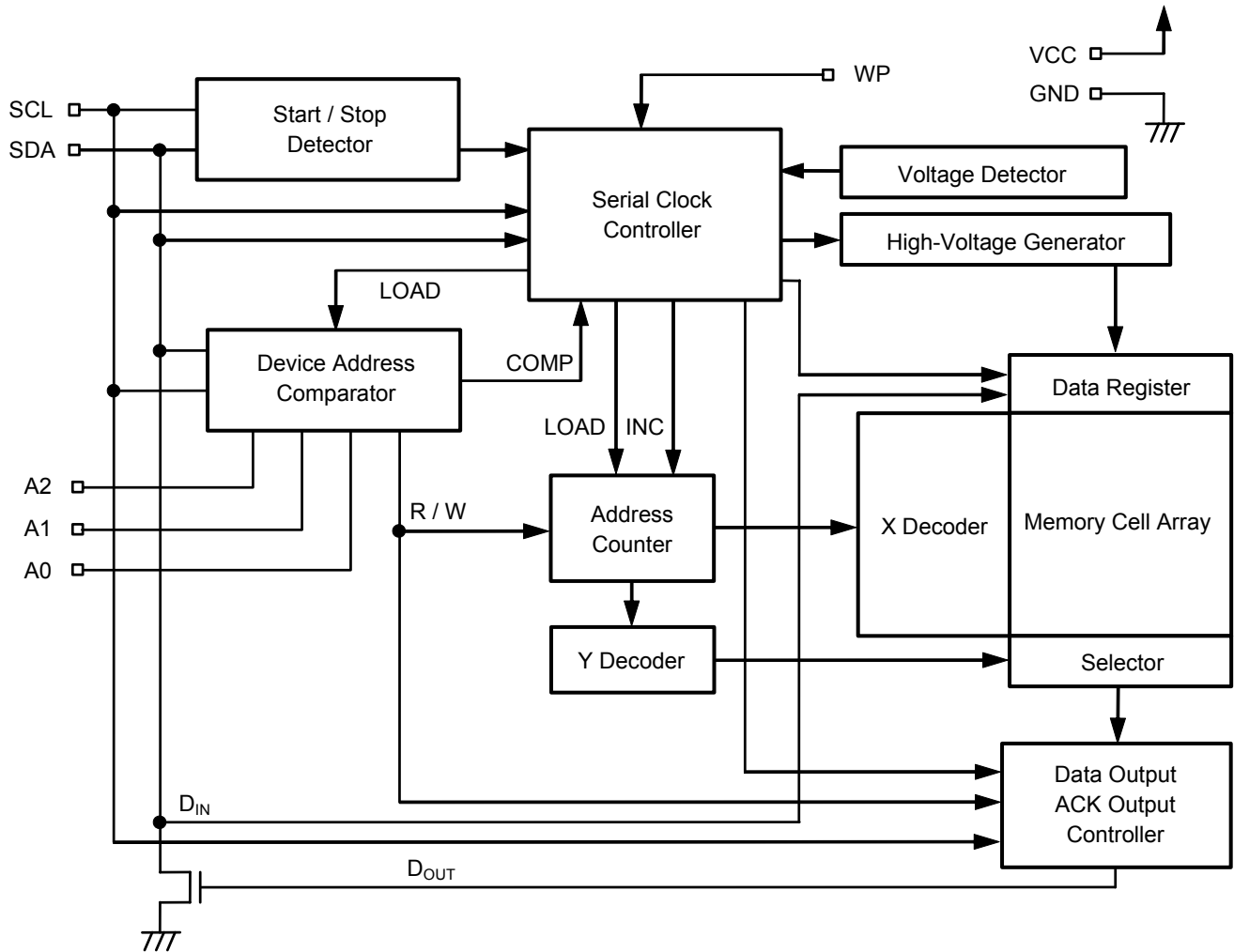

■ Pin Configuration

1. DFN-8(2030)

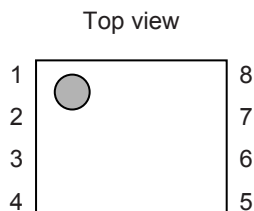

Pin No.	Symbol	Description
1	A0	Slave address input
2	A1	Slave address input
3	A2	Slave address input
4	GND	Ground
5	SDA <sup>*1</sup>	Serial data I/O
6	SCL <sup>*1</sup>	Serial clock input
7	WP	Write protect input Connected to V <sub>CC</sub> : Protection valid Open or connected to GND: Protection invalid
8	VCC	Power supply

\*1. Do not use it in "High-Z".

**Remark** For DFN-8(2030) package, connect the heatsink of backside to the board, and set electric potential open or GND. However, do not use it as the function of electrode.

■ **Absolute Maximum Ratings**

Table 1

Item	Symbol	Absolute Maximum Rating	Unit
Power supply voltage	$V_{CC}$	-0.3 to +6.5	V
Input voltage	$V_{IN}$	-0.3 to +6.5	V
A0 high level input voltage	$V_{HV}$	-0.3 to +10.0	V
Output voltage	$V_{OUT}$	-0.3 to +6.5	V
Operation ambient temperature	$T_{opr}$	-40 to +85	°C
Storage temperature	$T_{sta}$	-65 to +150	°C

**Caution** The absolute maximum ratings are rated values exceeding which the product could suffer physical damage. These values must therefore not be exceeded under any conditions.

■ **Recommended Operating Conditions**

Table 2

Item	Symbol	Condition	$T_a = -40^{\circ}\text{C}$ to $+85^{\circ}\text{C}$		Unit
			Min.	Max.	
Power supply voltage	$V_{CC}$	Read	1.7	5.5	V
		Write	1.7	5.5	V
High level input voltage	$V_{IH}$	$V_{CC} = 1.7\text{ V to }5.5\text{ V}$	$0.7 \times V_{CC}$	5.5	V
Low level input voltage	$V_{IL}$	$V_{CC} = 1.7\text{ V to }5.5\text{ V}$	-0.3	$0.3 \times V_{CC}$	V
A0 high level input voltage	$V_{HV}$	$V_{HV} - V_{CC} > 4.8\text{ V}$	7.0	10.0	V

■ **Pin Capacitance**

Table 3

( $T_a = +25^{\circ}\text{C}$ ,  $f = 1.0\text{ MHz}$ ,  $V_{CC} = 5.0\text{ V}$ )

Item	Symbol	Condition	Min.	Max.	Unit
Input capacitance	$C_{IN}$	$V_{IN} = 0\text{ V}$ (SCL, A0, A1, A2, WP)	-	8	pF
I/O capacitance	$C_{I/O}$	$V_{I/O} = 0\text{ V}$ (SDA)	-	8	pF

■ **Endurance**

Table 4

Item	Symbol	Operation Ambient Temperature	Min.	Max.	Unit
Endurance	$N_W$	$T_a = +25^{\circ}\text{C}$	$10^6$	-	cycle / word*1

\*1. For each address (Word: 8-bit)

■ **Data Retention**

Table 5

Item	Symbol	Operation Ambient Temperature	Min.	Max.	Unit
Data retention	-	$T_a = +25^{\circ}\text{C}$	100	-	year

■ DC Electrical Characteristics

Table 6

Item	Symbol	Condition	Ta = -40°C to +85°C		Unit
			V <sub>CC</sub> = 1.7 V to 5.5 V f <sub>SCL</sub> = 400 kHz		
			Min.	Max.	
Current consumption (READ)	I <sub>CC1</sub>	-	-	0.8	mA

Table 7

Item	Symbol	Condition	Ta = -40°C to +85°C		Unit
			V <sub>CC</sub> = 1.7 V to 5.5 V f <sub>SCL</sub> = 400 kHz		
			Min.	Max.	
Current consumption (WRITE)	I <sub>CC2</sub>	-	-	2.0	mA

Table 8

Item	Symbol	Condition	Ta = -40°C to +85°C		Unit
			V <sub>CC</sub> = 1.7 V to 5.5 V		
			Min.	Max.	
Standby current consumption	I <sub>SB</sub>	V <sub>IN</sub> = V <sub>CC</sub> or GND	-	1.0	μA
Input leakage current	I <sub>LI</sub>	SCL, SDA V <sub>IN</sub> = GND to V <sub>CC</sub>	-	1.0	μA
Output leakage current	I <sub>LO</sub>	SDA V <sub>OUT</sub> = GND to V <sub>CC</sub>	-	1.0	μA
Input current 1	I <sub>IL</sub>	A0, A1, A2, WP V <sub>IN</sub> < 0.3 × V <sub>CC</sub>	-	50.0	μA
Input current 2	I <sub>IH</sub>	A0, A1, A2, WP V <sub>IN</sub> > 0.7 × V <sub>CC</sub>	-	2.0	μA
Input impedance 1	Z <sub>IL</sub>	A0, A1, A2, WP V <sub>IN</sub> = 0.3 × V <sub>CC</sub>	30	-	kΩ
Input impedance 2	Z <sub>IH</sub>	A0, A1, A2, WP V <sub>IN</sub> = 0.7 × V <sub>CC</sub>	500	-	kΩ
Low level output voltage	V <sub>OL</sub>	I <sub>OL</sub> = 3.2 mA	-	0.4	V
		I <sub>OL</sub> = 1.5 mA	-	0.3	V
		I <sub>OL</sub> = 0.7 mA	-	0.2	V

■ **AC Electrical Characteristics**

**Table 9 Measurement Conditions**

Input pulse voltage	$0.2 \times V_{CC}$ to $0.8 \times V_{CC}$
Input pulse rising / falling time	20 ns or less
Output reference voltage	$0.3 \times V_{CC}$ to $0.7 \times V_{CC}$
Output load	100 pF

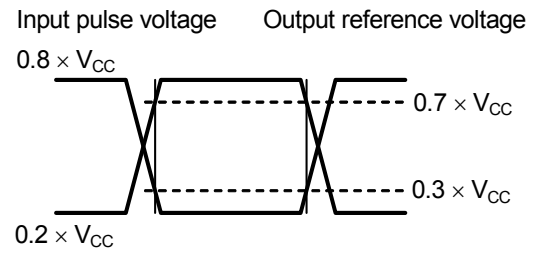

**Figure 1 Input / Output Waveform during AC Measurement**

**Table 10**

Item	Symbol	$T_a = -40^\circ\text{C}$ to $+85^\circ\text{C}$		Unit
		$V_{CC} = 1.7\text{ V}$ to $5.5\text{ V}$		
		Min.	Max.	
SCL clock frequency	$f_{SCL}$	0	400	kHz
SCL clock time "L"	$t_{LOW}$	1.3	–	$\mu\text{s}$
SCL clock time "H"	$t_{HIGH}$	0.6	–	$\mu\text{s}$
SDA output delay time	$t_{AA}$	0.1	0.9	$\mu\text{s}$
SDA output hold time	$t_{DH}$	50	–	ns
Start condition setup time	$t_{SU,STA}$	0.6	–	$\mu\text{s}$
Start condition hold time	$t_{HD,STA}$	0.6	–	$\mu\text{s}$
Data input setup time	$t_{SU,DAT}$	100	–	ns
Data input hold time	$t_{HD,DAT}$	0	–	ns
Stop condition setup time	$t_{SU,STO}$	0.6	–	$\mu\text{s}$
SCL, SDA rising time	$t_R$	–	0.3	$\mu\text{s}$
SCL, SDA falling time	$t_F$	–	0.3	$\mu\text{s}$
WP setup time	$t_{WS1}$	0	–	$\mu\text{s}$
WP hold time	$t_{WH1}$	0	–	$\mu\text{s}$
WP release setup time	$t_{WS2}$	0	–	$\mu\text{s}$
WP release hold time	$t_{WH2}$	0	–	$\mu\text{s}$
Bus release time	$t_{BUF}$	1.3	–	$\mu\text{s}$
Noise suppression time	$t_I$	–	100	ns
Write time	$t_{WR}$	–	5.0	ms

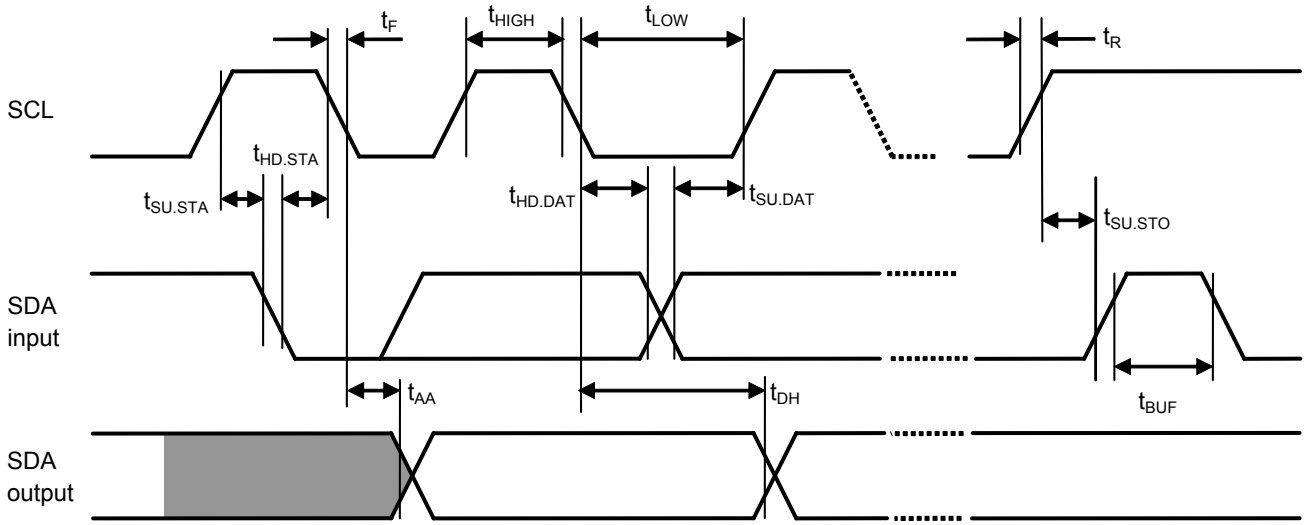

Figure 2 Bus Timing

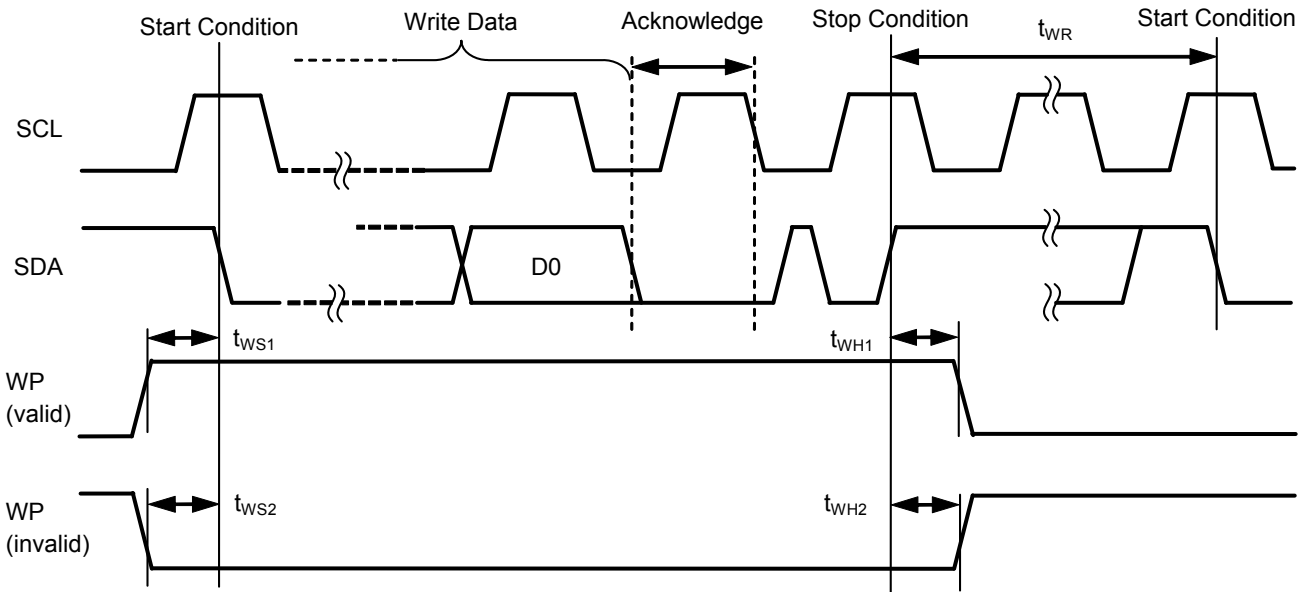

Figure 3 Write Cycle Timing

■ **Pin Functions**

**1. VCC (Power supply) pin**

The VCC pin is used to apply positive supply voltage. Regarding the applied voltage value, refer to "■ **Recommended Operating Conditions**". Set a bypass capacitor of about 0.1  $\mu\text{F}$  between the VCC pin and the GND pin to make the power supply voltage stable.

**2. A0, A1 and A2 (Slave address input) pins**

In this IC, to set the slave address, connect each of A0 pin, A1 pin and A2 pin to the GND pin or the VCC pin. Therefore the users can set 8 types of slave address by a combination of A0, A1, A2 pins.

Comparing the slave address transmitted from the master device and one that you set, makes possible to select one slave address from other devices connected onto the bus.

Each of A0 pin, A1 pin and A2 pin has a built-in pull-down resistor. In open, the pin is set to the same status as it connected to the GND pin.

**3. SDA (Serial data I/O) pin**

The SDA pin is used for the bi-directional transmission of serial data. This pin is a signal input pin, and an Nch open-drain output pin.

In use, generally, connect the SDA line to any other device which has the open-drain or open-collector output with Wired-OR connection by pulling up to  $V_{CC}$  by a resistor. **Figure 4** shows the relation with an output load.

**4. SCL (Serial clock input) pin**

The SCL pin is used for the serial clock input. Since the signals are processed at a rising or falling edge of the SCL clock, pay attention to the rising and falling time and comply with the specification.

**5. WP (Write protect input) pin**

When hardware write protect is used, connect the WP pin to  $V_{CC}$ . When hardware write protect is not used, be sure to leave the WP pin open or connect it to the GND pin.

When software write protect is used, it inhibits write in 50% of the lower address (addresses 00h to 7Fh) in all memory area according to the status of the protect register when the WP pin is left open or connected to the GND pin.

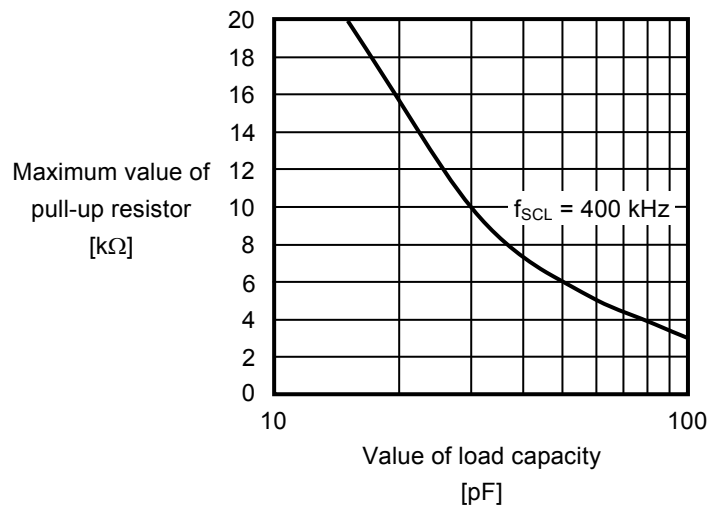

**Figure 4 Output Load**

## ■ Initial Delivery State

Initial delivery state of all addresses is "FFh".

## ■ Operation

### 1. Initialization operation after power-on

By a power-on-clear circuit, this IC initializes the internal circuit at the time of power-on. Perform the beginning (start condition) of the instruction transmission to this IC after the initialization by the power-on-clear circuit. Regarding the details of power-on-clear, refer to "5. Power-on-clear circuit" in "■ Usage".

### 2. Start condition

Start is identified by a "H" to "L" transition of the SDA line while the SCL line is stable at "H".  
Every operation begins from a start condition.

### 3. Stop condition

Stop is identified by a "L" to "H" transition of the SDA line while the SCL line is stable at "H".  
When a device receives a stop condition during a read sequence, the read operation is interrupted, and the device enters standby mode.  
When a device receives a stop condition during a write sequence, the reception of the write data is halted, and this IC initiates a write cycle.

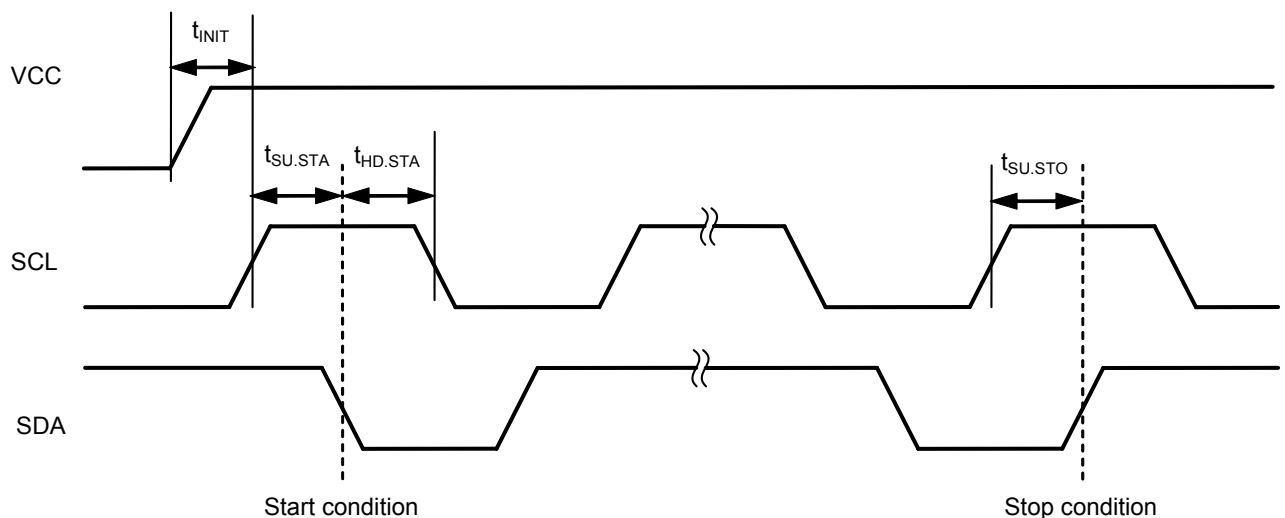
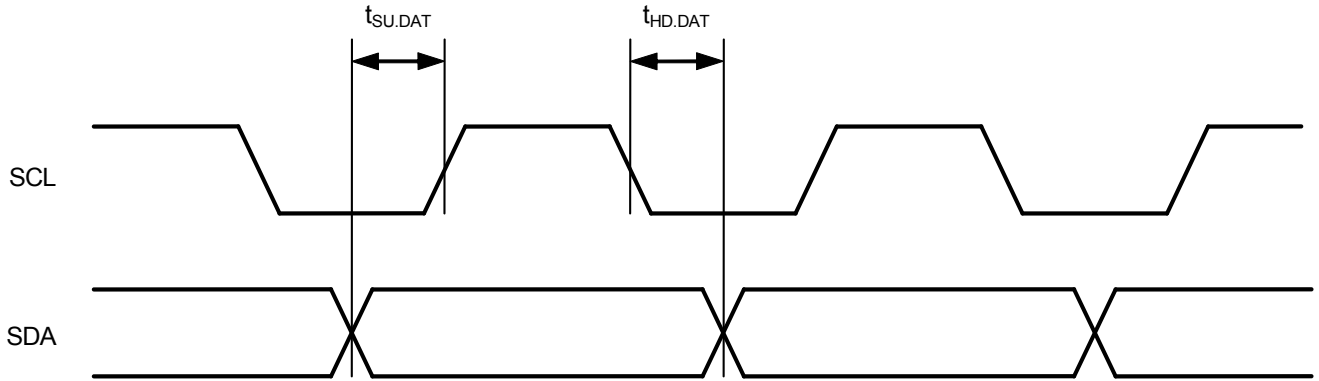

Figure 5 Start / Stop Conditions after Power-on



**4. Data transmission**

Changing the SDA line while the SCL line is "L", data is transmitted.  
Changing the SDA line while the SCL line is "H", a start or stop condition is recognized.



**Figure 6 Data Transmission Timing**

**5. Acknowledge**

The unit of data transmission is 8 bits. During the 9th clock cycle period the receiver on the bus pulls down the SDA line to acknowledge the receipt of the 8-bit data.  
When an internal write cycle is in progress, the device does not generate an acknowledge.

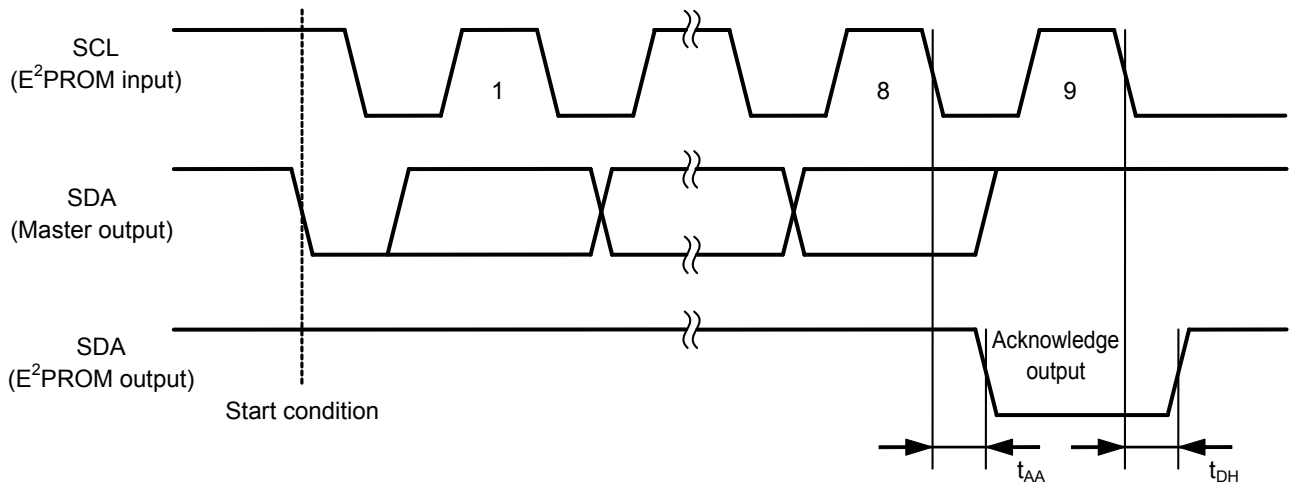

**Figure 7 Acknowledge Output Timing**



**7. Write**

**7.1 Byte write**

When the master sends a 7-bit device address and a 1-bit read / write instruction code set to "0", following a start condition, this IC acknowledges it.

This IC then receives an 8-bit word address and responds with an acknowledge. After this IC receives 8-bit write data and responds with an acknowledge, it receives a stop condition and that initiates the write cycle at the addressed memory.

During the write cycle all operations are forbidden and no acknowledge is generated.

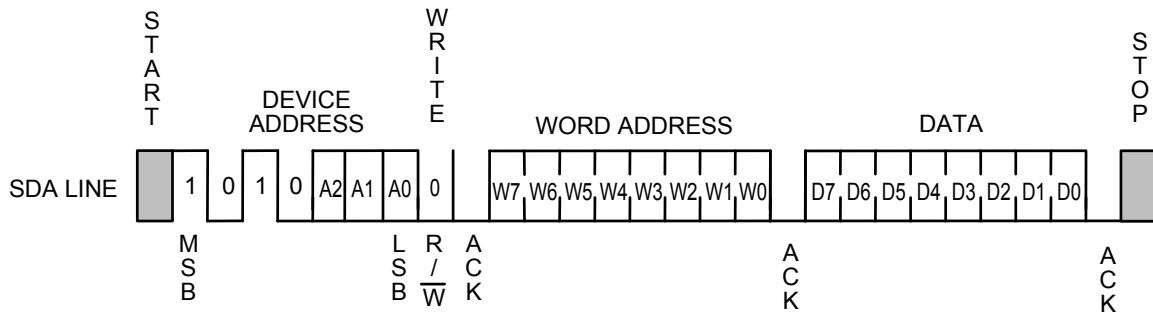

**Figure 9 Byte Write**

**7.2 Page write**

The page write mode allows up to 16 bytes to be written in a single write operation in this IC.

Its basic process to transmit data is as same as byte write, but it operates page write by sequentially receiving 8-bit write data as much data as the page size has.

When this IC receives a 7-bit device address and a 1-bit read / write instruction code set to "0", following a start condition, it generates an acknowledge. Then this IC receives an 8-bit word address, and responds with an acknowledge. After this IC receives 8-bit write data and responds with an acknowledge, it receives 8-bit write data corresponding to the next word address, and generates an acknowledge. This IC repeats reception of 8-bit write data and generation of acknowledge in succession. This IC can receive as many write data as the maximum page size.

Receiving a stop condition initiates a write cycle of the area starting from the designated memory address and having the page size equal to the received write data.

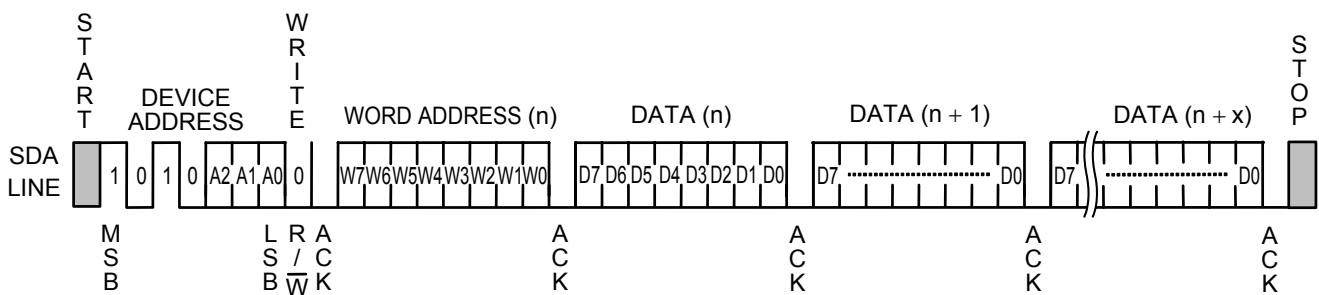

**Figure 10 Page Write**

The lower 4 bits of the word address are automatically incremented every time when it receives 8-bit write data. If the size of the write data exceeds 16 bytes, the higher 4 bits (W7 to W4) of the word address remain unchanged, and the lower 4 bits are rolled over and the last 16-byte data that this IC received will be overwritten.

**7.3 Hardware write protect**

Hardware write protect is available in this IC. When the WP pin is connected to  $V_{CC}$ , write in all memory area is inhibited.

Fix the WP pin during the period from the start condition to the stop condition in write operation (byte write and page write). Written data in the address is not assured if the condition of the WP pin is changed during this period. Regarding the timing of hardware write protect, refer to "**Figure 3 Write Cycle Timing**".

Be sure to connect the WP pin to GND pin when hardware write protect is not used. Hardware write protect is valid in the range of operation power supply voltage.

In this case, the users cannot perform the SWP (Set RSWP), CWP (Clear RSWP), PSWP (Set PSWP) instructions.

As seen in **Figure 11** when the hardware write protect is valid, this IC does not generate an acknowledge after data input.

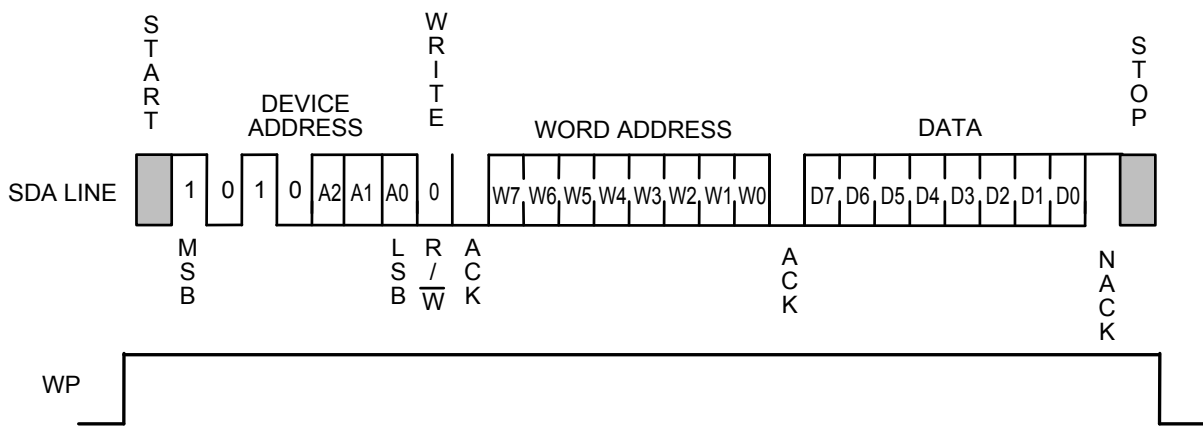

**Figure 11 Hardware Write Protect**

7.4 Software write protect

This IC has Permanent Software Write Protect (PSWP) and Reversible Software Write Protect (RSWP).

7.4.1 PSWP

If the software protect has been set with the PSWP (Set PSWP) instruction, 50% of the lower address (addresses 00h to 7Fh) in all memory is permanently write-protected. This write protect cannot be cleared by any instruction, or by power-cycling the device, and regardless the state of WP pin. Also, once the PSWP instruction has been successfully executed, this IC no longer acknowledges any instruction (device code of "0110") to access the write protect setting.

7.4.2 RSWP

If the software protect has been set with the SWP (Set RSWP) instruction, 50% of the lower address (addresses 00h to 7Fh) in all memory is write-protected. This write protect can be cleared with the CWP (Clear RSWP) instruction.

These two instructions have the same format as a byte write instruction, but have a different device code. Like the byte write instruction, it is followed by an address byte and a data byte, but in this case the contents can be set in all "Don't care". In the instructions of SWP and CWP, be sure to apply the high voltage of V<sub>HV</sub> to the A0 pin, and input "H" or "L" to the A1 pin and A2 pin.

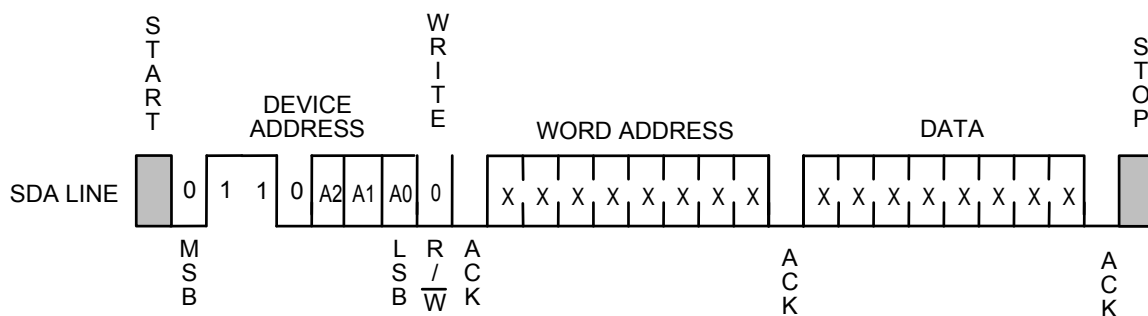

Remark X: Don't care

Figure 12 Software Write Protect

Table 11 Device Select Code

Instruction	Device Code				Slave Address			R/ $\bar{W}$	Pin Condition		
	B7	B6	B5	B4	B3	B2	B1	B0	A2	A1	A0
Memory area select* <sup>1</sup>	1	0	1	0	A2	A1	A0	R/ $\bar{W}$	A2	A1	A0
Set RSWP (SWP)	0	1	1	0	0	0	1	0	V <sub>SS</sub>	V <sub>SS</sub>	V <sub>HV</sub>
Clear RSWP (CWP)	0	1	1	0	0	1	1	0	V <sub>SS</sub>	V <sub>CC</sub>	V <sub>HV</sub>
Set PSWP (PSWP)* <sup>1</sup>	0	1	1	0	A2	A1	A0	0	A2	A1	A0
Read SWP	0	1	1	0	0	0	1	1	V <sub>SS</sub>	V <sub>SS</sub>	V <sub>HV</sub>
Read CWP	0	1	1	0	0	1	1	1	V <sub>SS</sub>	V <sub>CC</sub>	V <sub>HV</sub>
Read PSWP* <sup>1</sup>	0	1	1	0	A2	A1	A0	1	A2	A1	A0

\*1. Slave addresses (A2, A1, A0) are compared by the address input pins (A0, A1, A2) of a memory device with the address value which is set beforehand.

**Table 12 Acknowledge for Write Instruction ( $R/\bar{W}$  bit = 0)**

Status	WP	Instruction	ACK Output	Word Address	ACK Output	Data	ACK Output	Write
Permanent Software Write Protect (PSWP)	X	SWP, CWP or PSWP	No	Don't care	No	Don't care	No	No
		Page or byte write in lower 128 bytes	Yes	Address	Yes	Data	No	No
Reversible Software Write Protect (RSWP)	0	SWP	No	Don't care	No	Don't care	No	No
		CWP	Yes	Don't care	Yes	Don't care	Yes	Yes
		PSWP	Yes	Don't care	Yes	Don't care	Yes	Yes
		Page or byte write in lower 128 bytes	Yes	Address	Yes	Data	No	No
	1	SWP	No	Don't care	No	Don't care	No	No
		CWP	Yes	Don't care	Yes	Don't care	No	No
		PSWP	Yes	Don't care	Yes	Don't care	No	No
No software protect	0	SWP, CWP or PSWP	Yes	Don't care	Yes	Don't care	Yes	Yes
		Page or byte write	Yes	Address	Yes	Data	Yes	Yes
	1	SWP, CWP or PSWP	Yes	Don't care	Yes	Don't care	No	No
		Page or byte write	Yes	Address	Yes	Data	No	No

**Table 13 Acknowledge for Read Instruction ( $R/\bar{W}$  bit = 1)**

Status	Instruction	ACK Output	Word Address	ACK Output	Data	ACK Output
Permanent Software Write Protect (PSWP)	SWP, CWP or PSWP	No	Don't care	No	Don't care	No
Reversible Software Write Protect (RSWP)	SWP	No	Don't care	No	Don't care	No
	CWP	Yes	Don't care	No	Don't care	No
	PSWP	Yes	Don't care	No	Don't care	No
No software protect	SWP, CWP or PSWP	Yes	Don't care	No	Don't care	No





**8. Read**

**8.1 Current address read**

Either in writing or in reading this IC holds the last accessed memory address. The memory address is maintained when the instruction transmission is not interrupted, and the memory address is maintained as long as the power voltage does not decrease less than the operating voltage.

The master device can read the data at the memory address of the current address pointer without assigning the word address as a result, when it recognizes the position of the address pointer in this IC. This is called "current address read".

In the following the address counter in this IC is assumed to be "n".

When this IC receives a 7-bit device address and a 1-bit read / write instruction code set to "1" following a start condition, it responds with an acknowledge.

Next an 8-bit data at the address "n" is sent from this IC synchronous to the SCL clock. The address counter is incremented and the content of the address counter becomes n + 1. The master device outputs stop condition not an acknowledge, the reading of this IC is ended.

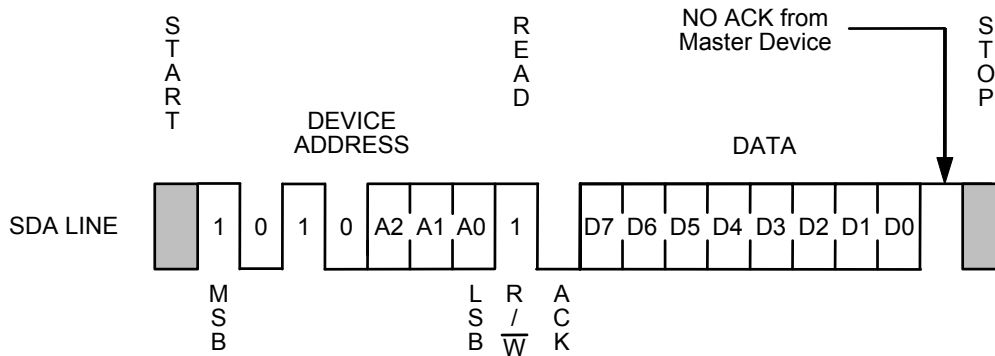

**Figure 14 Current Address Read**

Attention should be paid to the following point on the recognition of the address pointer in this IC. In Read, the memory address counter in this IC is automatically incremented after output of the 8th bit of the data. In Write, on the other hand, the higher bits of the memory address (the higher bits of the word address)<sup>\*1</sup> are left unchanged and are not incremented.

\*1. The higher 4 bits (W7 to W4) of the word address.

8.2 Random read

Random read is used to read the data at an arbitrary memory address.

A dummy write is performed to load the memory address into the address counter.

When this IC receives a 7-bit device address and a 1-bit read / write instruction code set to "0" following a start condition, it responds with an acknowledge.

This IC then receives an 8-bit word address and responds with an acknowledge. The memory address is loaded to the address counter in this IC by these operations. Reception of write data does not follow in a dummy write whereas reception of write data follows in byte write and in page write.

Since the memory address is loaded into the memory address counter by dummy write, the master device can read the data starting from the arbitrary memory address by transmitting a new start condition and performing the same operation in the current address read.

That is, when this IC receives a 7-bit device address and a 1-bit read / write instruction code set to "1", following a start condition signal, it responds with an acknowledge. Next, 8-bit data is transmitted from this IC in synchronous to the SCL clock. The master device outputs stop condition not an acknowledge, the reading of this IC is ended.

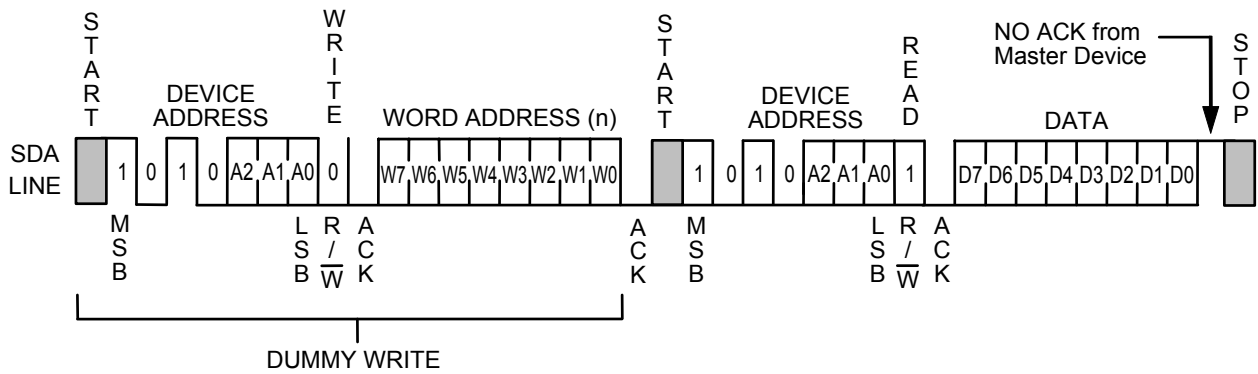

Figure 15 Random Read

### 8.3 Sequential read

When this IC receives a 7-bit device address and a 1-bit read / write instruction code set to "1" following a start condition both in current address read and random read, it responds with an acknowledge.

When an 8-bit data is output from this IC synchronous to the SCL clock, the address counter is automatically incremented.

When the master device responds with an acknowledge, the data at the next memory address is transmitted. Response with an acknowledge by the master device has the memory address counter in this IC incremented and makes it possible to read data in succession. This is called sequential read.

The master device outputs stop condition not an acknowledge, the reading of this IC is ended.

Data can be read in succession in the sequential read mode. When the memory address counter reaches the last word address, it rolls over to the first word address.

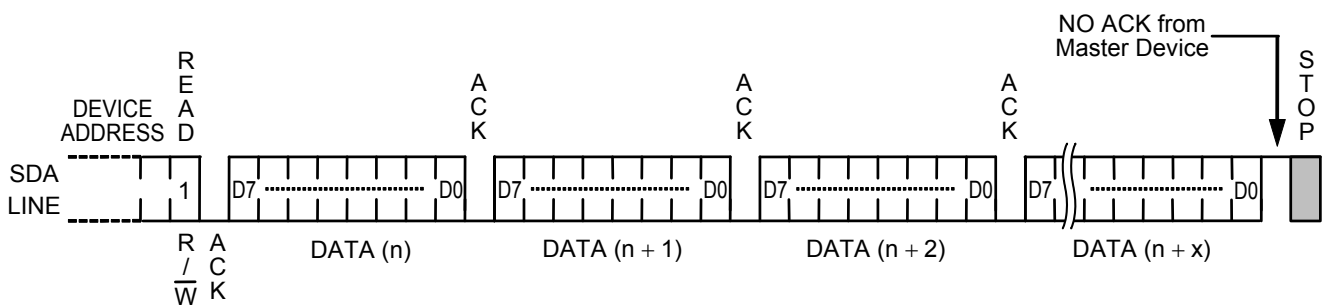

**Figure 16 Sequential Read**

■ Usage

1. A pull-up resistor to SDA I/O pin and SCL input pin

In consideration of I<sup>2</sup>C-bus protocol function, the SDA I/O pin should be connected with a pull-up resistor. This IC cannot transmit normally without using a pull-up resistor.

In case that the SCL input pin of this IC is connected to the Nch open-drain output pin of the master device, connect the SCL pin with a pull-up resistor. As well, in case the SCL input pin of this IC is connected to the tri-state output pin of the master device, connect the SCL pin with a pull-up resistor in order not to set it in "High-Z". This prevents this IC from error caused by an uncertain output (High-Z) from the tri-state pin when resetting the master device during the voltage drop.

2. Equivalent circuits of input pin and I/O pin

The SCL pin and the SDA pin of this IC does not have a built-in pull-down or pull-up resistor. Each of A0 pin, A1 pin, A2 pin and WP pin has a built-in pull-down resistor. The SDA pin is an open-drain output. The followings are equivalent circuits of the pins.

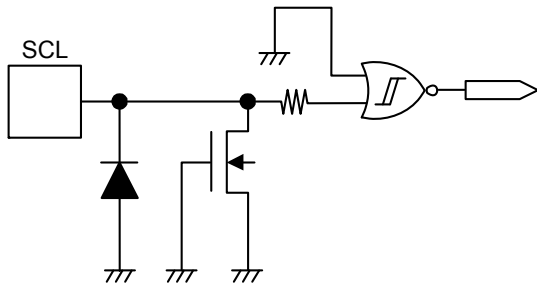

Figure 17 SCL Pin

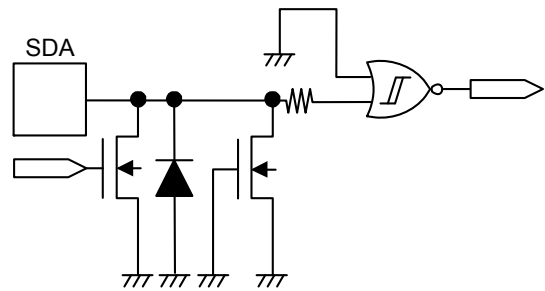

Figure 18 SDA Pin

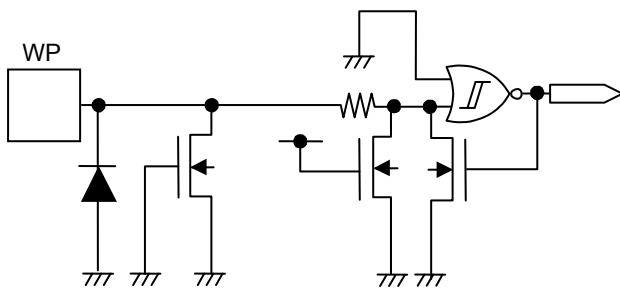

Figure 19 WP Pin

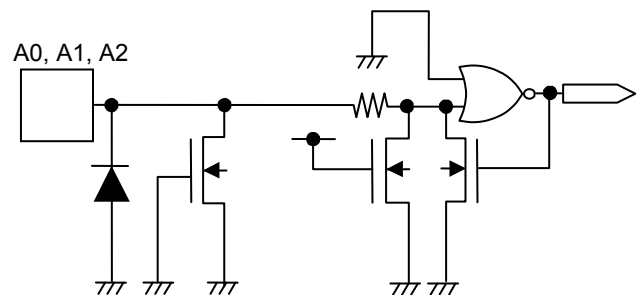

Figure 20 A0, A1, A2 Pin

### 3. Phase adjustment of the I<sup>2</sup>C-bus product

The I<sup>2</sup>C-bus product does not have a pin to reset (the internal circuit). The users cannot forcibly reset it externally. If the communication interrupted, the users need to handle it as you do for software.

In this IC, users are able to reset the internal circuit by inputting a start condition and a stop condition.

Although the reset signal is input to the master device, this IC's internal circuit does not go in reset, but it does by inputting a stop condition to this IC. This IC keeps the same status thus cannot do the next operation. Especially, this case corresponds to that only the master device is reset when the power supply voltage drops.

If the power supply voltage restored in this status, input the instruction after resetting (adjusting the phase with the master device) this IC. How to reset is shown below.

#### [How to reset this IC]

This IC is able to be reset by a start and stop instructions. When this IC is reading data "0" or is outputting the acknowledge signal, outputs "0" to the SDA line. In this status, the master device cannot output an instruction to the SDA line. In this case, terminate the acknowledge output operation or the Read operation, and then input a start condition.

**Figure 21** shows this procedure.

First, input a start condition. Then transmit 9 clocks (dummy clock) of SCL. During this time, the master device sets the SDA line to "H". By this operation, this IC interrupts the acknowledge output operation or data output, so input a start condition\*1. When a start condition is input, this IC is reset. To make doubly sure, input the stop condition to this IC. The normal operation is then possible.

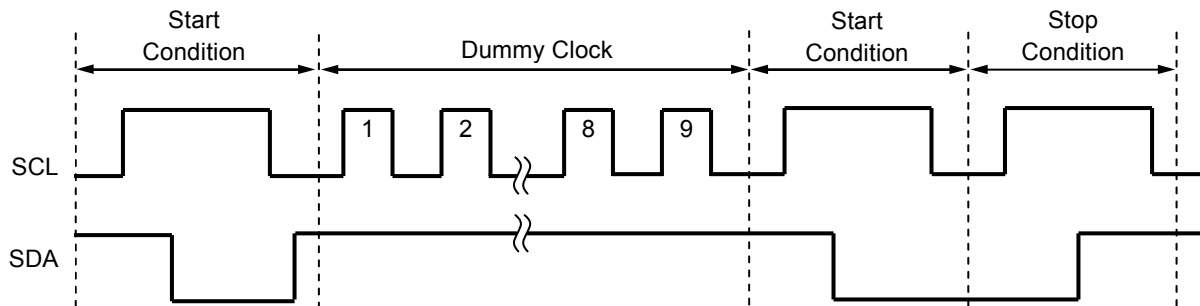

**Figure 21 Resetting Method**

\*1. After 9 clocks (dummy clock), if the SCL clock continues to being output without inputting a start condition, this IC may go in the write operation when it receives a stop condition. To prevent this, input a start condition after 9 clocks (dummy clock).

**Remark** Regarding this reset procedure with dummy clock, it is recommended to perform at the system initialization after applying the power supply voltage.

#### 4. Acknowledge check

The I<sup>2</sup>C-bus protocol includes an acknowledge check function as a handshake function to prevent a communication error. This function allows detection of a communication failure during data communication between the master device and this IC. This function is effective to prevent malfunction, so it is recommended to perform an acknowledge check with the master device.

#### 5. Power-on-clear circuit

By power-on-clear circuit, this IC initializes at the same time when the power supply voltage is raised. After the initialization by the power-on-clear circuit is completed, this IC becomes standby state. In order to use this IC safely, raise the power supply voltage depending on the following conditions.

##### 5.1 Initialization time

This IC initializes at the same time when the power supply voltage is raised. Input instructions to this IC after initialization. This IC does not accept any instruction during initialization.

Figure 22 shows the initialization time of this IC.

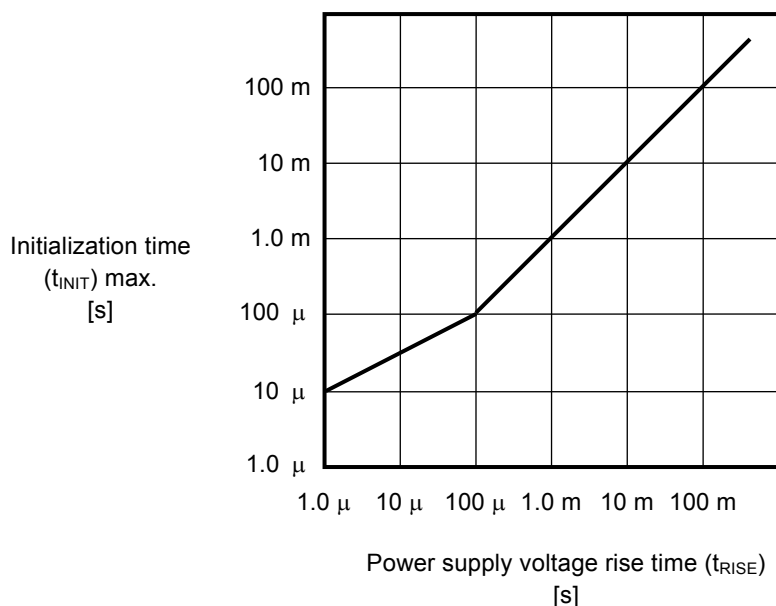

Figure 22 Initialization Time

**5.2 Caution when raising the power supply voltage**

The internal circuit of this IC is reset by the power-on-clear circuit. In order for the power-on-clear circuit to operate normally, the condition showed in **Table 14** must be obeyed for raising the power supply voltage.

Due to the voltage drop, this IC may not perform normal communication if the power-on-clear operation condition is not fulfilled, even when the master device is reset.

However, the interface of this IC is reset normally and the master device can make normal communication if phase adjustment is performed, even when the power-on-clear operation condition of this IC is not fulfilled.

**Table 14**

Item	Symbol	Min.	Max.	Unit
Power-off time	$t_{OFF}$	100	—	$\mu\text{s}$
Power-off voltage	$V_{BOT}$	—	0.6	V

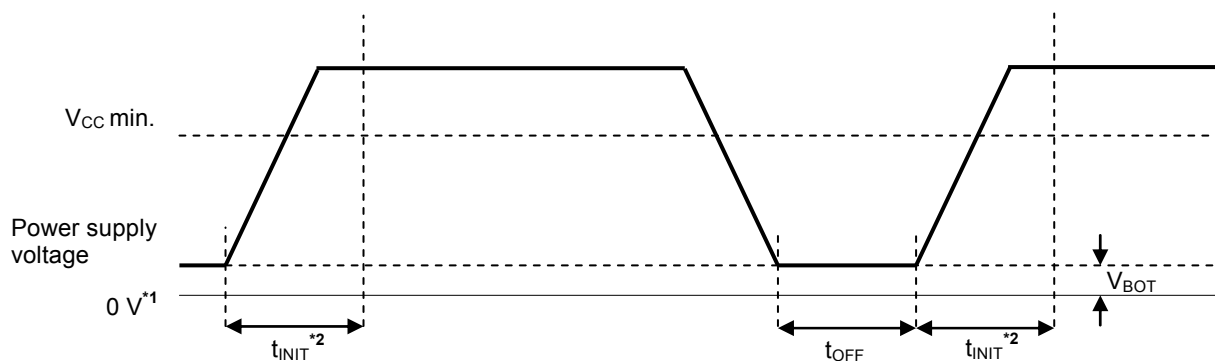

- \*1. 0 V means that there is no potential difference between the VCC pin and the GND pin of this IC.
- \*2.  $t_{INIT}$  is the time to initialize the internal IC. This IC does not accept any instruction during the initialization time.

**Figure 23 Caution When Raising the Power Supply Voltage**

**6. Write protect function during the low power supply voltage**

This IC has a built-in detection circuit which operates with the low power supply voltage, cancels write when the power supply voltage drops and power-on. Its detection and release voltages are 1.3 V typ. (refer to **Figure 24**).

This IC cancels write by detecting a low power supply voltage when it receives a stop condition. In the data trasmission and the write operation, data in the address written during the low power supply voltage is not assurable.

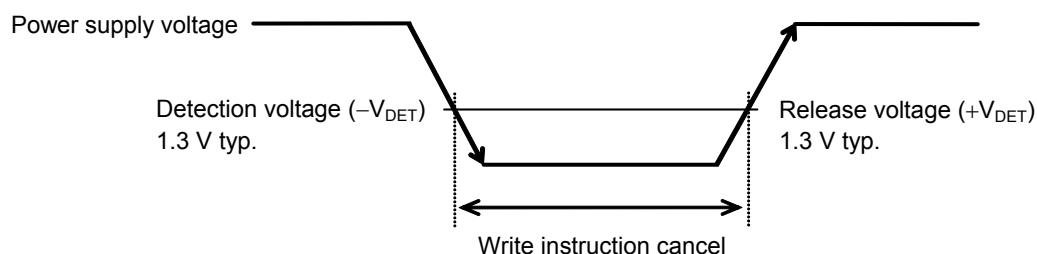

**Figure 24 Operation during Low Power Supply Voltage**

**7. Data hold time ( $t_{HD,DAT} = 0 \text{ ns}$ )**

If SCL and SDA of this IC are changed at the same time, it is necessary to prevent a start / stop condition from being mistakenly recognized due to the effect of noise.

This IC may error if it does not recognize a start / stop condition correctly during transmission.

In this IC, it is recommended to set the delay time of  $0.3 \mu\text{s}$  minimum from a falling edge of SCL for the SDA.

This is to prevent this IC from going in a start / stop condition due to the time lag caused by the load of the bus line.

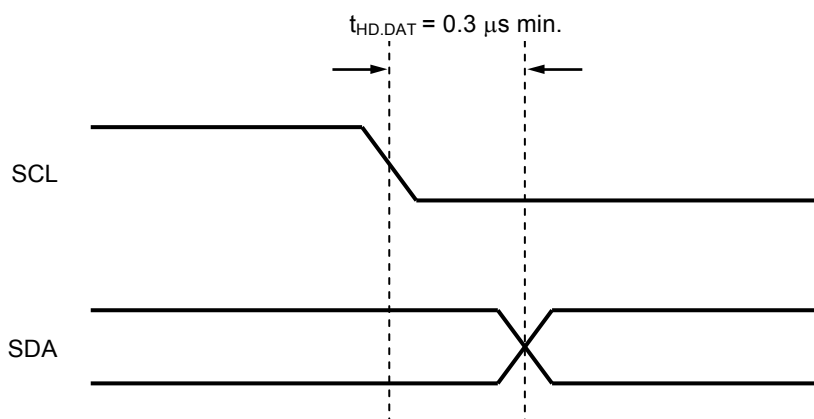

Figure 25 Data Hold Time

**8. SDA pin and SCL pin noise suppression time**

This IC includes a built-in low-pass filter at the SDA pin and the SCL pin to suppress noise. If the power supply voltage is 5.0 V, noise with a pulse width of 100 ns or less can be suppressed.

For details of the assurable value, refer to noise suppression time ( $t_i$ ) in **Table 10** in "■ AC Electrical Characteristics".

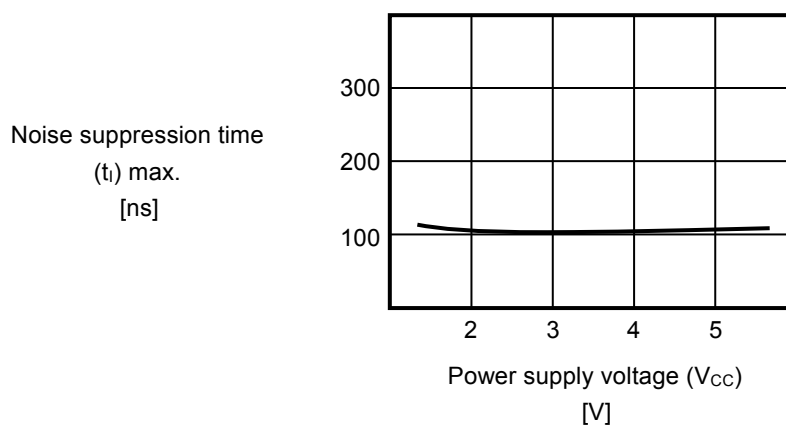
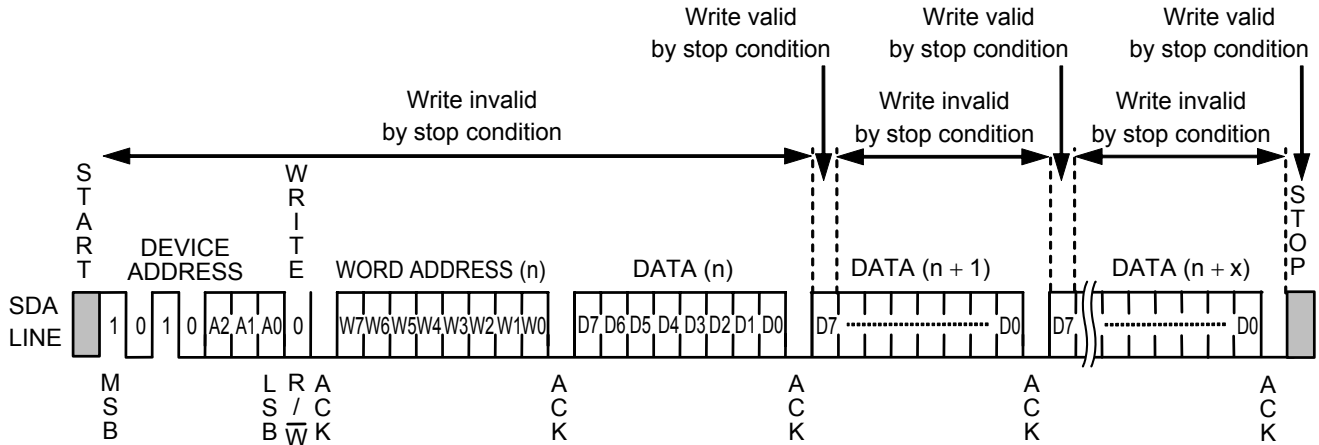

Figure 26 Noise Suppression Time for SDA Pin and SCL Pin



**9. Operation when input stop condition during input write data**

This IC does the write operation only when it receives data of 1 byte or more and receives a stop condition immediately after an acknowledge output.  
 Refer to **Figure 27** regarding details.



**Figure 27 Write Operation by Inputting Stop Condition during Write**

**10. Command cancel by start condition**

By a start condition, users are able to cancel command which is being input. However, adjust the phase while this IC is outputting "L" because users are not able to input a start condition. When users cancel the command, there may be a case that the address will not be identified. Use random read for the read operation, not current address read.

**■ Precautions**

- Do not operate these ICs in excess of the absolute maximum ratings. Attention should be paid to the power supply voltage, especially. The surge voltage which exceeds the absolute maximum ratings can cause latch-up and malfunction. Perform operations after confirming the detailed operation condition in the data sheet.
- Operations with moisture on this IC's pins may occur malfunction by short-circuit between pins. Especially, in occasions like picking this IC up from low temperature tank during the evaluation. Be sure that not remain frost on this IC's pin to prevent malfunction by short-circuit.  
 Also attention should be paid in using on environment, which is easy to dew for the same reason.
- Do not apply an electrostatic discharge to this IC that exceeds the performance ratings of the built-in electrostatic protection circuit.
- ABLIC Inc. claims no responsibility for any and all disputes arising out of or in connection with any infringement of the products including this IC upon patents owned by a third party.

## Disclaimers (Handling Precautions)

1. All the information described herein (product data, specifications, figures, tables, programs, algorithms and application circuit examples, etc.) is current as of publishing date of this document and is subject to change without notice.
2. The circuit examples and the usages described herein are for reference only, and do not guarantee the success of any specific mass-production design.  
ABLIC Inc. is not responsible for damages caused by the reasons other than the products described herein (hereinafter "the products") or infringement of third-party intellectual property right and any other right due to the use of the information described herein.
3. ABLIC Inc. is not responsible for damages caused by the incorrect information described herein.
4. Be careful to use the products within their specified ranges. Pay special attention to the absolute maximum ratings, operation voltage range and electrical characteristics, etc.  
ABLIC Inc. is not responsible for damages caused by failures and / or accidents, etc. that occur due to the use of the products outside their specified ranges.
5. When using the products, confirm their applications, and the laws and regulations of the region or country where they are used and verify suitability, safety and other factors for the intended use.
6. When exporting the products, comply with the Foreign Exchange and Foreign Trade Act and all other export-related laws, and follow the required procedures.
7. The products must not be used or provided (exported) for the purposes of the development of weapons of mass destruction or military use. ABLIC Inc. is not responsible for any provision (export) to those whose purpose is to develop, manufacture, use or store nuclear, biological or chemical weapons, missiles, or other military use.
8. The products are not designed to be used as part of any device or equipment that may affect the human body, human life, or assets (such as medical equipment, disaster prevention systems, security systems, combustion control systems, infrastructure control systems, vehicle equipment, traffic systems, in-vehicle equipment, aviation equipment, aerospace equipment, and nuclear-related equipment), excluding when specified for in-vehicle use or other uses. Do not apply the products to the above listed devices and equipments without prior written permission by ABLIC Inc. Especially, the products cannot be used for life support devices, devices implanted in the human body and devices that directly affect human life, etc.  
Prior consultation with our sales office is required when considering the above uses.  
ABLIC Inc. is not responsible for damages caused by unauthorized or unspecified use of our products.
9. Semiconductor products may fail or malfunction with some probability.  
The user of the products should therefore take responsibility to give thorough consideration to safety design including redundancy, fire spread prevention measures, and malfunction prevention to prevent accidents causing injury or death, fires and social damage, etc. that may ensue from the products' failure or malfunction.  
The entire system must be sufficiently evaluated and applied on customer's own responsibility.
10. The products are not designed to be radiation-proof. The necessary radiation measures should be taken in the product design by the customer depending on the intended use.
11. The products do not affect human health under normal use. However, they contain chemical substances and heavy metals and should therefore not be put in the mouth. The fracture surfaces of wafers and chips may be sharp. Be careful when handling these with the bare hands to prevent injuries, etc.
12. When disposing of the products, comply with the laws and ordinances of the country or region where they are used.
13. The information described herein contains copyright information and know-how of ABLIC Inc.  
The information described herein does not convey any license under any intellectual property rights or any other rights belonging to ABLIC Inc. or a third party. Reproduction or copying of the information from this document or any part of this document described herein for the purpose of disclosing it to a third-party without the express permission of ABLIC Inc. is strictly prohibited.
14. For more details on the information described herein, contact our sales office.

2.2-2018.06

# Mouser Electronics

Authorized Distributor

Click to View Pricing, Inventory, Delivery & Lifecycle Information:

[ABLIC:](#)

[S-34C02BI-A8T1U5](#)



Компания «ЭлектроПласт» предлагает заключение долгосрочных отношений при поставках импортных электронных компонентов на взаимовыгодных условиях!

Наши преимущества:

- Оперативные поставки широкого спектра электронных компонентов отечественного и импортного производства напрямую от производителей и с крупнейших мировых складов;
- Поставка более 17-ти миллионов наименований электронных компонентов;
- Поставка сложных, дефицитных, либо снятых с производства позиций;
- Оперативные сроки поставки под заказ (от 5 рабочих дней);
- Экспресс доставка в любую точку России;
- Техническая поддержка проекта, помощь в подборе аналогов, поставка прототипов;
- Система менеджмента качества сертифицирована по Международному стандарту ISO 9001;
- Лицензия ФСБ на осуществление работ с использованием сведений, составляющих государственную тайну;
- Поставка специализированных компонентов (Xilinx, Altera, Analog Devices, Intersil, Interpoint, Microsemi, Aeroflex, Peregrine, Syfer, Eurofarad, Texas Instrument, Miteq, Cobham, E2V, MA-COM, Hittite, Mini-Circuits, General Dynamics и др.);

Помимо этого, одним из направлений компании «ЭлектроПласт» является направление «Источники питания». Мы предлагаем Вам помощь Конструкторского отдела:

- Подбор оптимального решения, техническое обоснование при выборе компонента;
- Подбор аналогов;
- Консультации по применению компонента;
- Поставка образцов и прототипов;
- Техническая поддержка проекта;
- Защита от снятия компонента с производства.



#### Как с нами связаться

**Телефон:** 8 (812) 309 58 32 (многоканальный)

**Факс:** 8 (812) 320-02-42

**Электронная почта:** [org@eplast1.ru](mailto:org@eplast1.ru)

**Адрес:** 198099, г. Санкт-Петербург, ул. Калинина, дом 2, корпус 4, литера А.