

Fan & Blower Accessories

ACCESSORIES FOR TUBEAXIAL FANS

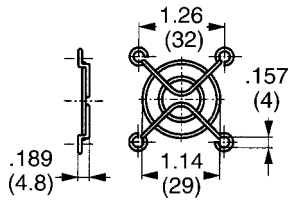

400 Series Grill Guard - LZ29-1



600 Series Grill Guard - LZ28-1



8000 Series Grill Guard - LZ32-4

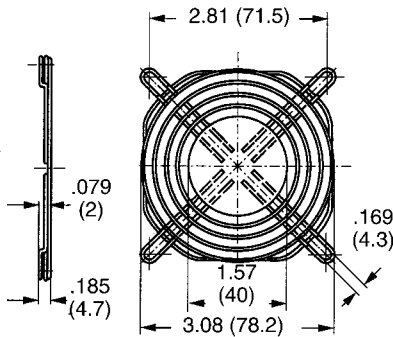

8000 Series
Plastic Finger Guard
Part Number
for screw connection: LZ32-2
Part Number
with barbed inserts: LZ32-3



8000 Series Grill Guard with 5 rings is Part Number - LZ22N

8000 Series
Plastic Finger Guard
Part Number: LZ32P



8300 and 3300 Series
Spacers, Part Numbers: LZ212 and LZ260
8400 Series
Spacer, Part Number: LZ261

Part Number: LZ212
Screw clip of rust-resistant spring steel.
For mounting fans with threaded pin 3.5
DIN 7970.



Part Number:
LZ260 / LZ261

Fiberglass spacer for screw mounting over both fan mounting flanges

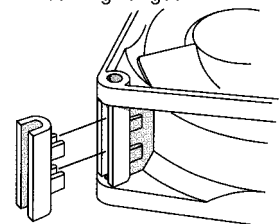

ACCESSORIES FOR TUBEAXIAL FANS



3000 Series

Metal Finger Guard
Part Number: LZ23-1

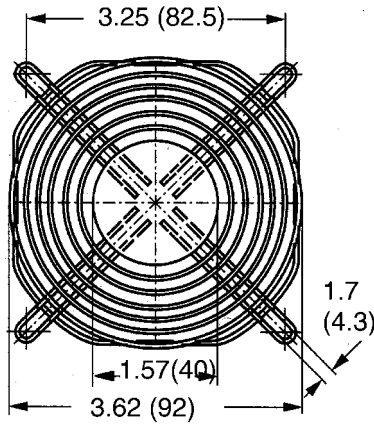

3000 Series

Plastic Finger Guard
Part Number
for screw connection: LZ23-2
Part Number
with barbed inserts: LZ23-3

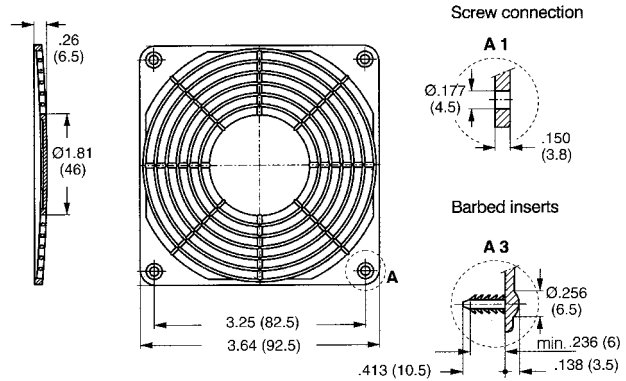

4000 and 9000 Series

Metal Finger Guard
Part Number: LZ30-4

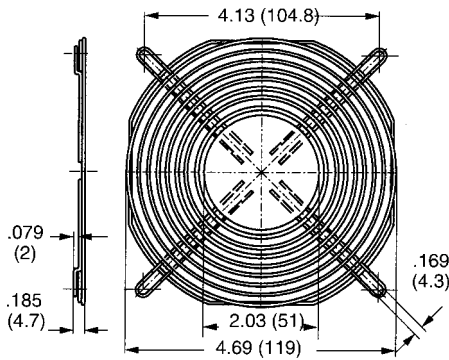

4000 and 9000 Series

Plastic Finger Guards (PPO)
Part Number
for screw connection: LZ30-5
Part Number
with barbed inserts: LZ30-6

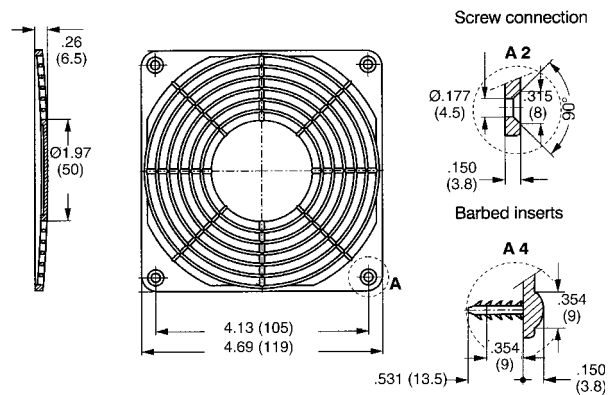

4000 and 9000 Series

LZ40N - black fiberglass plastic frame
LZ60 - stainless steel wire mesh filter
LZ40-1 - mounting brackets

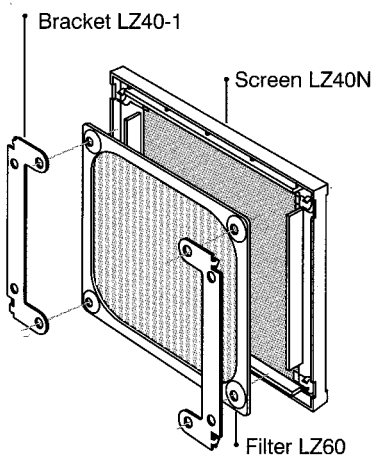

4000 and 9000 Series

Plastic Finger Guard
Part Number: LZ30P

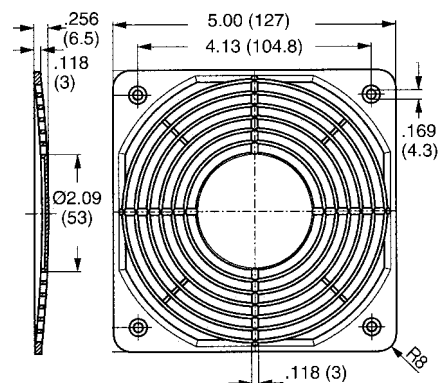

Call **ebm Industries** at 860-674-1515 • Fax 860-674-8536 • E-mail: sales@ebm.com for Technical Assistance

© ebm Industries, Inc. 2001. ebm Industries, Inc. reserves the right to change any specifications or data without notice.

ACCESSORIES FOR TUBEAXIAL FANS



5200 and 5900 Series
Metal Grill Guard
Part Number LZ35

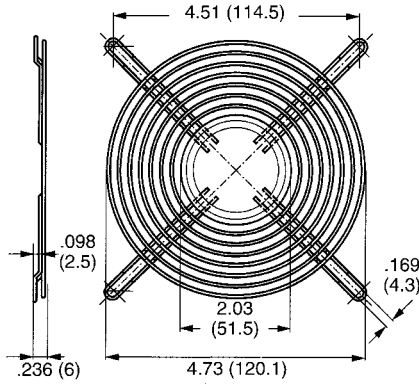

5200 and 5900 Series
Plastic Finger Guard, screw connection - LZ33-1
Plastic Finger Guard Barbed Insert - LZ33-2

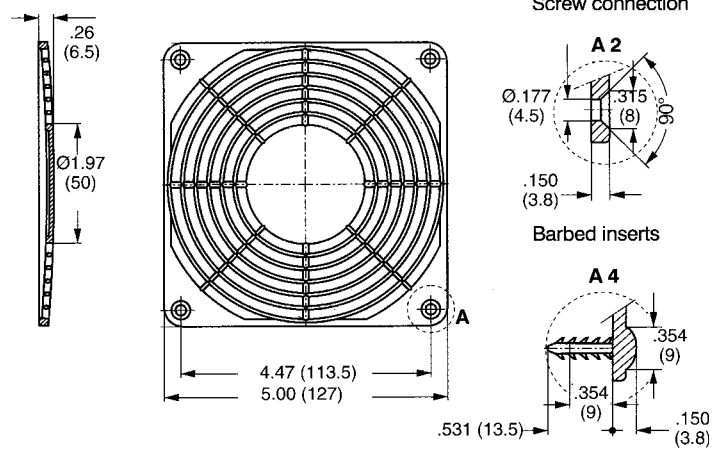

5100 and 5600 Series
Metal Grill Guard
Part Number LZ25

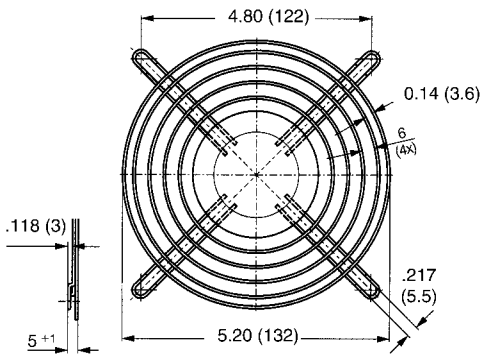

7000 Series
Metal Grill Guard
Part Number LZ36

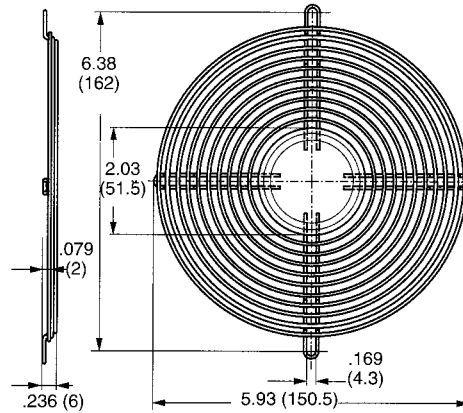

6400 Series
Metal Grill Guard
Part Number LZ37

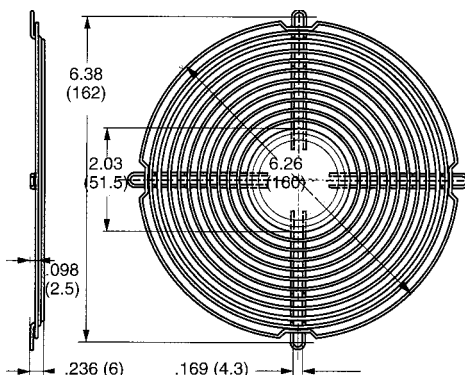

6000 Series
Metal Grill Guard
Part Number LZ38

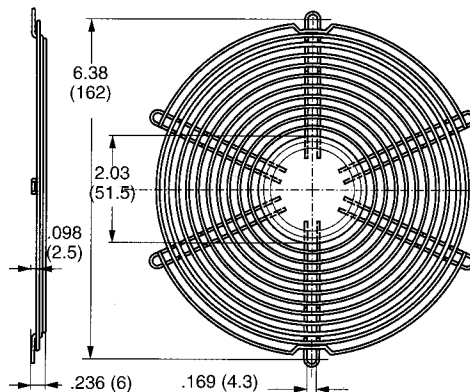

Call **ebm Industries** at 860-674-1515 • Fax 860-674-8536 • E-mail: sales@ebm.com for Technical Assistance

©ebm Industries, Inc. 2001. ebmIndustries, Inc. reserves the right to change any specifications or data without notice.

ACCESSORIES FOR TUBEAXIAL FANS



METAL FINGER GUARDS

FAN SIZE/SERIES	DESCRIPTION	PART NUMBER
120mm	8-ring Finger Guard	LZ30
150mm	5-ring Finger Guard	LZ27
150mm	10-ring Finger Guard	LZ24
172mm	6-ring Finger Guard	LZ26
DV6200	Finger Guard	LZ39

W2G115 and W1G115 Series
Metal Finger Guard
Part Number: 9496-2-4039

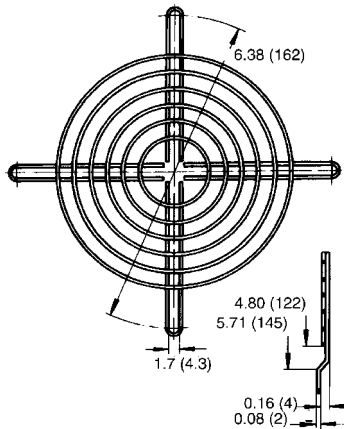

W2G115 and W1G115 Series
Metal Finger Guard
Part Number: 50951-2-4039

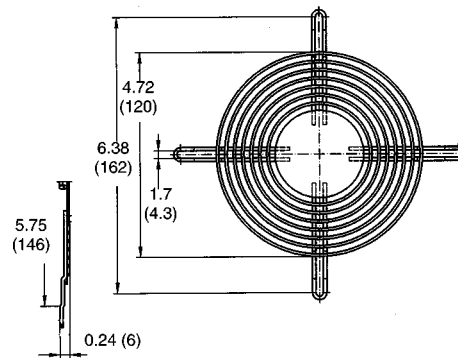

W2G130 and W2S130 Series
Metal Finger Guard
Part Number 51019-2-4039

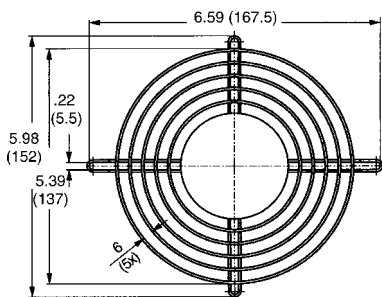

W2E142 Series
Metal Finger Guard
Part Number 3749-2-4039

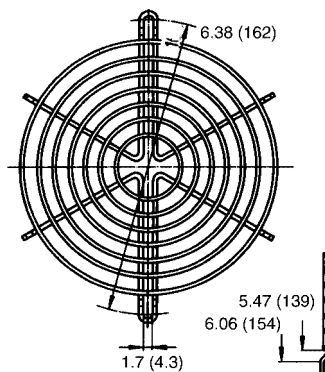

W2G130, W2S130, W2E142 Series
Metal Finger Guard
Part Number 50950-2-4039

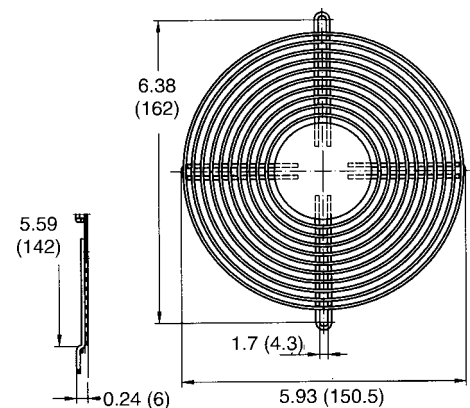

ACCESSORIES FOR TUBEAXIAL FANS



W2E143 Series
Metal Finger Guard
Part Number 4013-2-4039

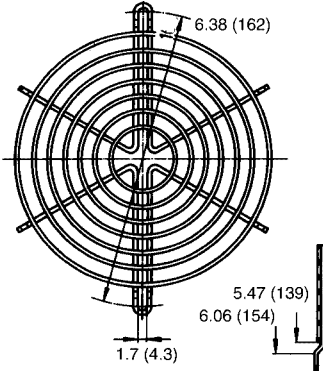

W2E143 Series
Metal Finger Guard
Part Number 50952-2-4039



W1G180 Series
Metal Finger Guard
Part Number 26388-2-4039

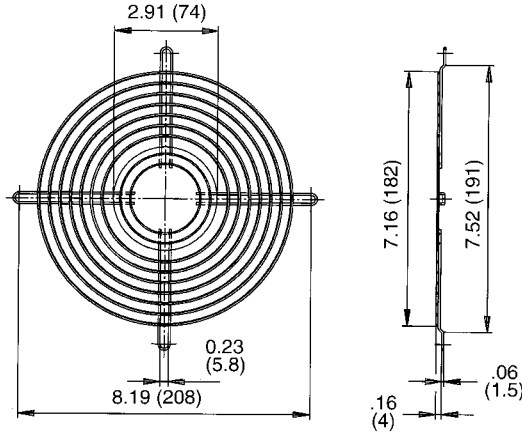

W1G200 and W2E200 Series
Tubeaxial Finger Guard
Part Number - 78128-2-4039



W1G250 and W2E250 Series
Tubeaxial Finger Guard
Part Number - 09418-2-4039

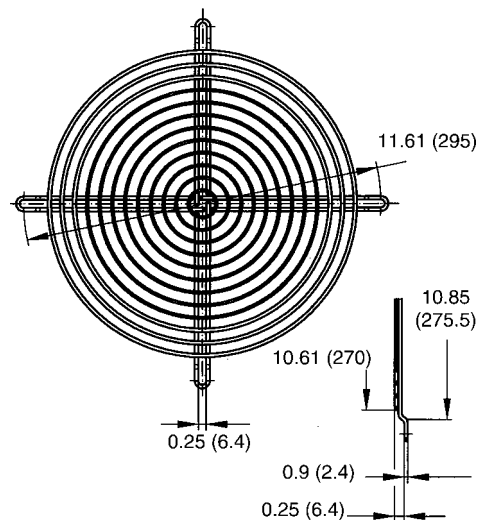

Call **ebm Industries** at 860-674-1515 • Fax 860-674-8536 • E-mail: sales@ebm.com for Technical Assistance

©ebm Industries, Inc. 2001. ebmIndustries, Inc. reserves the right to change any specifications or data without notice.

ACCESSORIES FOR TUBEAXIAL FANS



4000, 9000, 5100, 5200,
5600, 5900, 7000 Series
Screw Clip
Part Number LZ210

Screw clip of hardened
steel. For mounting fans
with threaded pin 6-32
UNC and/or 3.5
DIN 7970.



Mounting Clip for M4 Screw
Part Number: LZ215

Metal Filter
4000 Series - LZ60
8000 Series - LZ60-8

Variofan NTCThermistor
Part Number: LZ370

Thermistor for speed-controlled fan
operation. Temperature range 30...50 °C.



Required performance date:

$R_{25} = 100 \text{ k}\Omega \pm 5\%$
 $B\text{-value} = 4190 \pm 2\%$
 $P_{\text{max}} = 0,25 \text{ W}$

3300, 4300, 8300 Series
Screw Clip

Part Number: LZ212

Screw clip of rust-resistant spring steel.
For mounting fans with
threaded pin 3.5
DIN 7970.

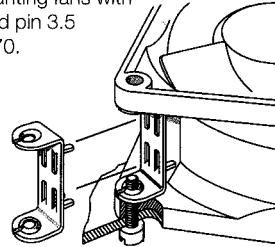

Mounting Clip for M4 Screw
Part Number: LZ215

Connecting cable with molded plug, (PVC,
black). Stranded wires with multi-core cable
ends. For all types of fan with flat pins
3.0 x 0.5 mm.

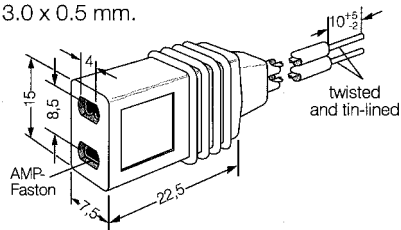

Type	Cable length	Pins
LZ120	24.0 (610)	.0197 (0.5)
LZ126	39.4 (1000)	.0197 (0.5)
LZ130-1	24.0 (610) UL approved	.0197 (0.5)

Additional versions are available on special order

FILTER KIT

for 119mm fans

- 10016-1-5170 Grill guard
- 10017-1-5170 Grill guard and filter
- 10018-1-5170 Grill guard, filter, spacer



ebm Plug and Cord Sets

.110 x .02 inch (2.8 x .5 mm)

STRAIGHT CONNECTION

- 24 inch (610mm) 1434-4-6711
- 39 inch (1000mm) 1477-4-6711
- 79 inch (2000mm) 1505-4-6711

RIGHT ANGLE CONNECTION

- 24 inch (610mm) 1434-4-6711-1
- 33 inch (914mm) 1434-4-6711-3
- 80 inch (2032mm) 1434-4-6711-80

Call **ebm Industries** at 860-674-1515 • Fax 860-674-8536 • E-mail: sales@ebm.com for Technical Assistance

© ebm Industries, Inc. 2001. ebm Industries, Inc. reserves the right to change any specifications or data without notice.

Inlet Rings for Motorized Impellers and Mixed-Flo Blowers



Part Number	Impeller Number	Mixed-Flo Number	Max. Dimensions (inches)		
			a	b	c
9566-2-4013	133		5.08 (129)	3.43 (87)	0.51 (13)
9588-2-4013	175, 180 & 190		7.28 (185)	5.12 (130)	0.67 (17)
9609-2-4013	220		9.96 (253)	6.10 (155)	0.79 (20)
9597-2-4013	R1G225 R4E225-AR R2E225-BB		8.27 (210)	5.87 (149)	1.10 (28)
9607-2-4013	R4S225 R4E225-AC 250		8.78 (223)	6.57 (167)	0.87 (22)
9614-2-4013	280		10.04 (255)	7.40 (188)	0.98 (25)
9621-2-4013	310		11.81 (300)	7.60 (193)	1.69 (43)
51357-2-4013	355		13.78 (350)	8.90 (226)	2.36 (60)
IR/265497	RH28M		10.43 (265)	7.09 (180)	1.69 (43)
IR/265498	RH31M		11.81 (300)	7.56 (192)	2.09 (53)
IR/265499	RH35M		13.19 (335)	8.98 (228)	2.28 (58)
IR/265500	RH40M	RM35D	14.72 (374)	10.12 (257)	2.60 (66)
IR/265501	RH45M	RM40D	16.26 (413)	11.30 (287)	2.80 (71)
IR/265502	RH50M	RM45D	17.95 (456)	12.72 (323)	3.11 (79)
IR/265503	RH56M	RM50D	19.88 (505)	14.33 (364)	3.43 (87)
IR/265504	RH63M	RM56D	22.05 (560)	16.14 (410)	3.74 (95)
IR/265505	RH71M		25.00 (635)	18.11 (460)	4.17 (106)

Call **ebm Industries** at 860-674-1515 • Fax 860-674-8536 • E-mail: sales@ebm.com for Technical Assistance

©ebm Industries, Inc. 2001. ebmIndustries, Inc. reserves the right to change any specifications or data without notice.

Finger Guards for Centrifugal Blowers



Part Number	Blower Wheel Size	Max. Dim.- in. (mm)		
		a	b	c
9489-2-4039	085	3.5 (90)	2.9 (74)	3.3 (84)
9485-2-4039	097 ◊	-	-	4.5 (114)
9490-2-4039	108	5.0 (126)	4.3 (110)	4.7 (118)
9494-2-4039	120	5.5 (140)	4.9 (124)	5.2 (132)
9500-2-4039	133 ◊	-	-	5.7 (145)
9492-2-4039	140/146	6.6 (168)	6.0 (152)	6.2 (158)
9503-2-4039	160	7.1 (180)	6.4 (162)	6.9 (175)
9493-2-4039	180	8.1 (205)	7.2 (183)	7.6 (194)

◊ – Dual inlet wire guard with three holes at 120°

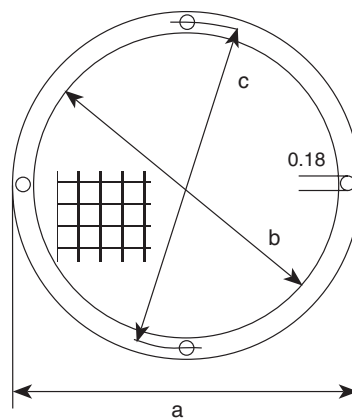

Material is galvanized wire.

Technical Note on Scroll Housing

18° EXPANSION, FOR REFERENCE ONLY

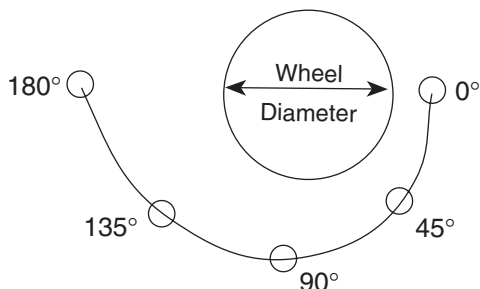

Forward Curved Wheels use 6° - 12° expansion, 10° normal
Backward Curved Wheel normally uses 18° half scroll
MODIFY TO SUIT YOUR NEEDS

REFERENCE ONLY BASED ON A 10 INCH DIAMETER WHEEL

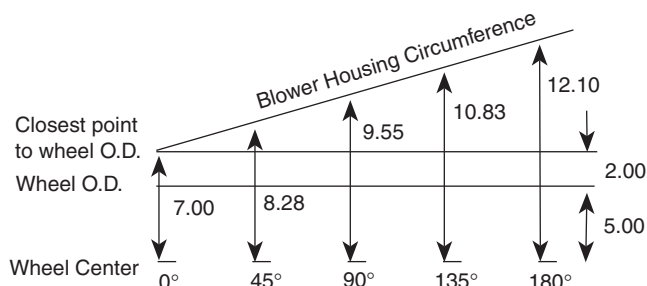

ANGLE AROUND WHEEL FROM STARTING POINT
(a half scroll housing expands for approx. 180 degrees)
NOTE: Expansion angle must always increase.

Hall Effect Monitor

Selected ebm blowers ordered with this option monitor the speed of the blower with a device consisting of a magnet and solid state switch built into the motor. The output signal is a low voltage DC pulse train that can be incorporated into the end product to trigger an audible or visual alarm or to initiate an orderly system shutdown. This device is suited for telecommunications, computer, peripheral and copier applications, or others as required.

Hall Effect Monitor for AC Models

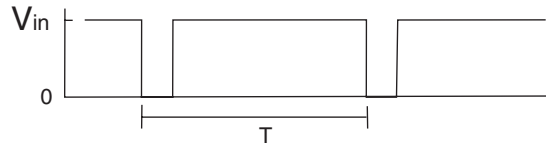

Input = 4.5 to 16 VDC; $T = 60/\text{RPM}$; $V_{out} \approx v$
Output Impedance = 4.7 K nominal.

Hall Effect Monitor for Brushless DC Models

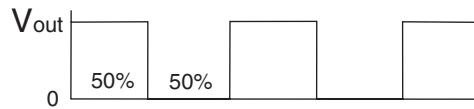

2 pulse / revolution – $V_{out} \approx 5v$; Output current = 5mA max.

MOTOR WIRING DIAGRAMS

A. PSC "Type E" Motor

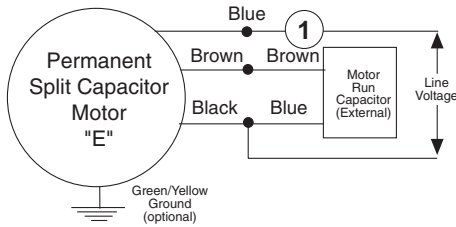

B. Shaded Pole Motor

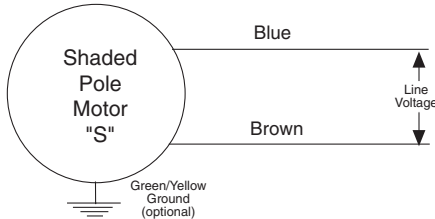

1 An extra capacitor can be connected in series to yield lower RPM for multi-speed requirements

C. PSC Motor

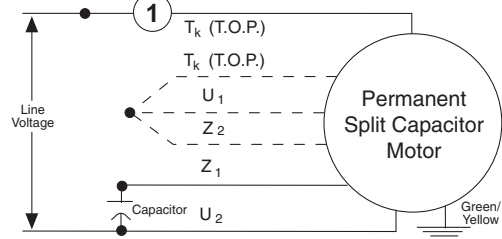

D. PSC Motor

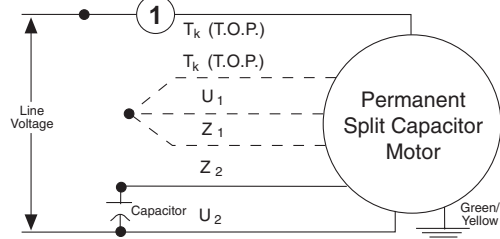

Dotted lines not supplied on all designs

VarioFans have Temperature Dependent Speed Control

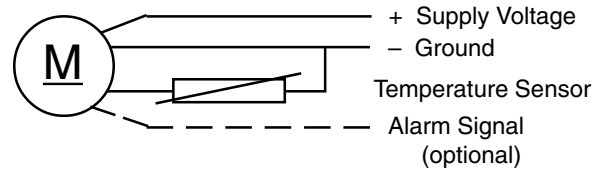

Alarms & Connectors for ebm/Papst Tubeaxial Fans

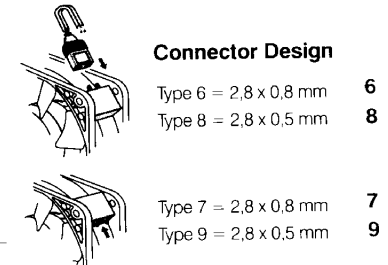
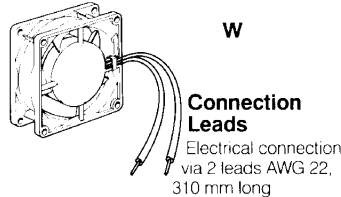
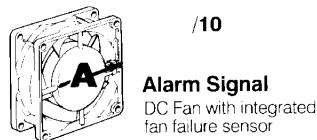
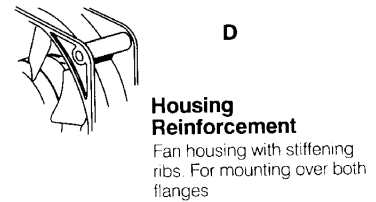
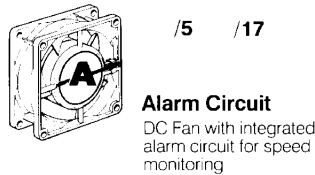
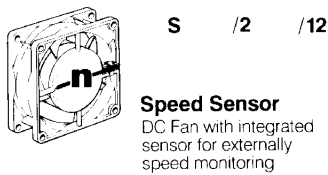

Characteristics of Fan Signals and Operation with different Alarm Signals

Speed Sensor Type: S, /2, /12
These fans produce speed-proportional square-wave signals via an integrated sensor. This 'electronic' tachometer is used to monitor the fan speed.

Alarm Signal Type: /10
These fans produce a continuous signal output when operating interference-free. When fan speed falls below 75 - 85% of the nominal speed, short low impulses are generated. The greater the fall below the alarm speed, the greater the low impulse width becomes. At rest there is a continuous low signal.

Alarm Switching Signal Type: /5, /17
These fans produce speed-dependent, directly usable high/low square-wave signals via integrated alarm switching circuits.
/5 models: Switching circuit is galvanically separated with a separate current supply.
/17: Direct current supply via motor; the switching circuit is not separate.

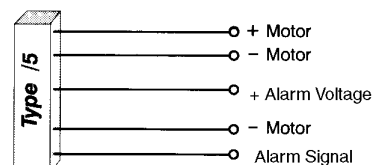
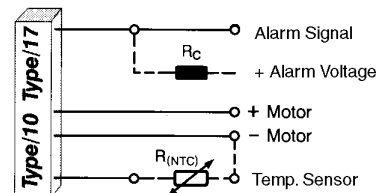
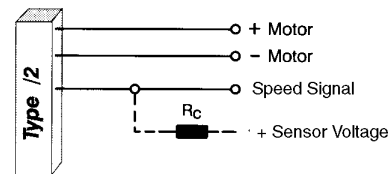
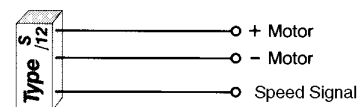

HOW TO USE CAPACITORS FOR MULTI-SPEED BLOWERS

It is possible to make any ebm blower with a PSC motor a multi-speed blower by adding a second or third capacitor on the load line (blue) at or near the value of the motor run capacitor. Actual capacitor value and RPM achieved are dependent on the nature of each application.

PLASTIC CAPACITORS

Part Number	Size (mfd)	Temp. Range (°C)	Max. Dim in. (mm)		
			a	b	d
02100-4-7320	1	-25 to +85	1.1 (28)	2.2 (55)	0.5 (12)
99282-4-7320	1.5	-25 to +85	1.1 (28)	2.2 (55)	0.5 (12)
99283-4-7320	2	-25 to +85	1.1 (28)	2.2 (55)	0.5 (12)
02103-4-7320	2.5	-25 to +85	1.1 (28)	2.2 (55)	0.5 (12)
02102-4-7320	3	-25 to +85	1.1 (28)	2.2 (55)	0.5 (12)
99284-4-7320	4	-25 to +85	1.3 (32)	2.2 (55)	0.5 (12)
02101-4-7320	5	-25 to +85	1.4 (36)	2.3 (58)	0.5 (12)
99285-4-7320	6	-25 to +85	1.4 (36)	2.8 (70)	0.5 (12)
99286-4-7320	8	-25 to +85	1.6 (40)	2.6 (67)	0.5 (12)
99287-4-7320	10	-25 to +85	1.6 (40)	2.8 (70)	0.5 (12)

(For larger sizes consult factory)

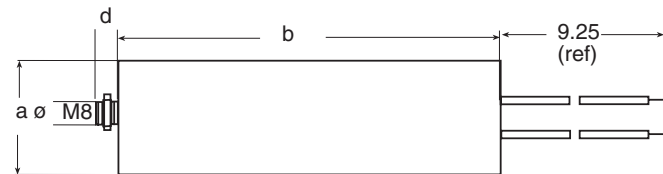

METAL CAPACITORS

Part Number	Size (mfd)	Temp. Range (°C)	Max. Dim in. (mm)		
			a	b	c
2151-4-7320	1	-25 to +85	1.0 (25)	2.9 (74)	1.1 (29)
2155-4-7320	1.5	-25 to +85	1.0 (25)	2.9 (74)	1.1 (29)
2156-4-7320	2	-25 to +85	1.0 (25)	2.9 (74)	1.1 (29)
2159-4-7320	2.5	-25 to +85	1.2 (30)	2.8 (71)	1.3 (34)
2160-4-7320	3	-25 to +85	1.2 (30)	3.9 (99)	1.3 (34)
2161-4-7320	4	-25 to +85	1.2 (30)	4.1 (104)	1.3 (34)
2162-4-7320	5	-25 to +85	1.4 (35)	4.1 (104)	1.5 (39)
2163-4-7320	6	-25 to +85	1.4 (35)	4.0 (101)	1.5 (38)
2164-4-7320	7	-25 to +85	1.6 (40)	4.0 (101)	1.7 (43)
2165-4-7320	8	-25 to +85	1.4 (35)	4.0 (101)	1.5 (38)
2166-4-7320	10	-25 to +85	1.4 (35)	3.9 (99)	1.5 (39)
2167-4-7320	12	-25 to +85	1.6 (40)	3.9 (99)	1.7 (43)
2168-4-7320	16	-25 to +75	1.8 (46)	6.3 (160)	1.9 (48)
2169-4-7320	20	-25 to +75	1.8 (46)	6.3 (160)	1.9 (48)
2170-4-7320	25	-25 to +75	1.8 (46)	6.3 (160)	1.9 (48)

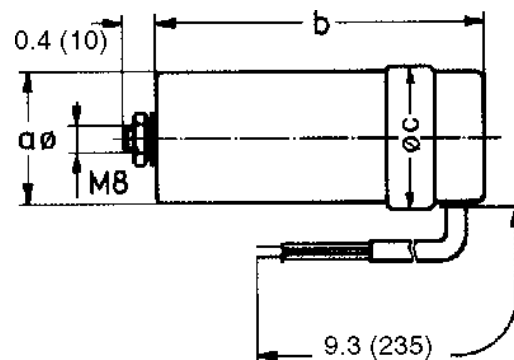

Call **ebm Industries** at 860-674-1515 • Fax 860-674-8536 • E-mail: sales@ebm.com for Technical Assistance

Metal Capacitors

with UL, CSA and VDE Approvals



Part Number	Size (mfd)	Temp Range °C
450-20-0017	1	-20 to +85
450-20-0018	1.5	-20 to +85
450-20-0019	2	-20 to +85
450-20-0020	2.5	-20 to +85
450-20-0021	3	-20 to +85
450-20-0022	4	-20 to +85
450-20-0023	5	-20 to +85
450-20-0024	6	-20 to +85
450-20-0025	7	-20 to +85
450-20-0026	8	-20 to +85
450-20-0027	10	-20 to +85
450-20-0028	12	-20 to +85

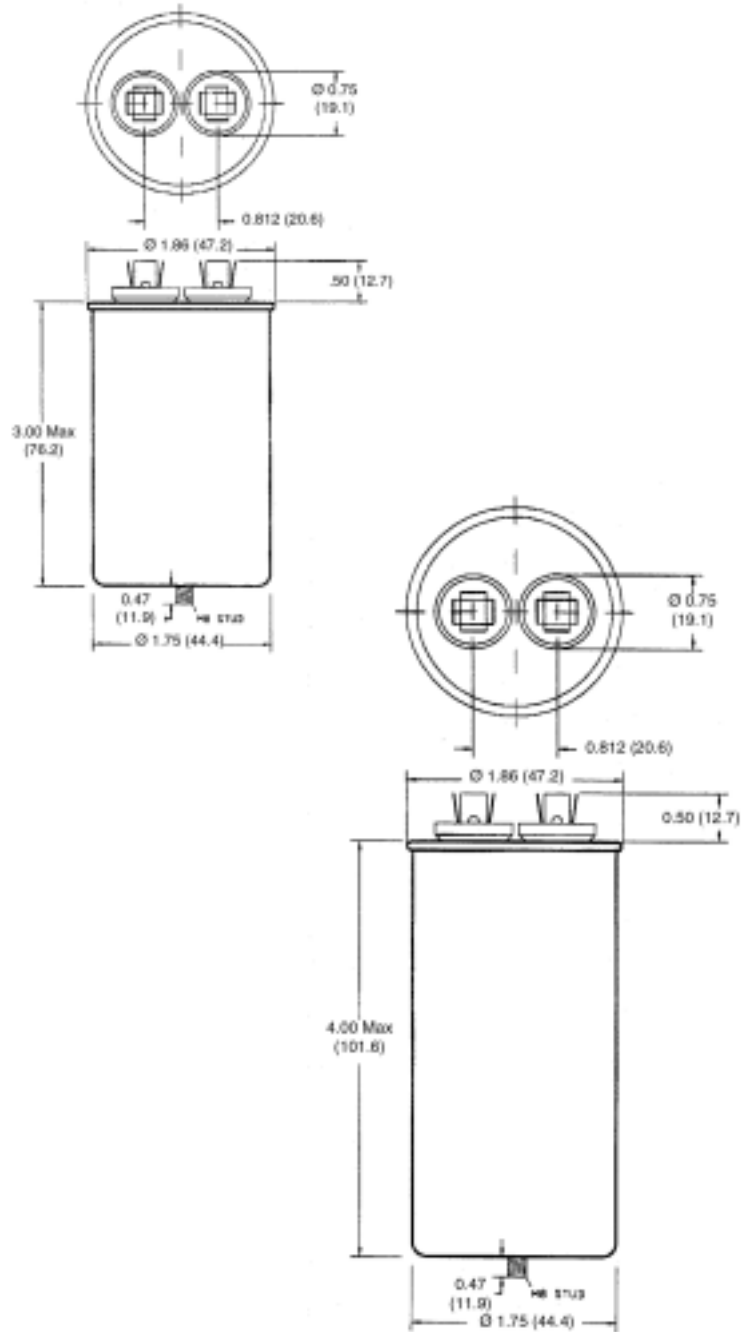

LARGER SIZE (see drawing)

Part Number	Size (mfd)	Temp Range °C
450-20-0029	16	-20 to +85
450-20-0030	20	-20 to +85
450-20-0031	25	-20 to +85
450-20-0033	30	-20 to +85
450-20-0034	40	-20 to +85

Part Number for Boot	710-00-0042
----------------------	-------------

Boot Dimensions

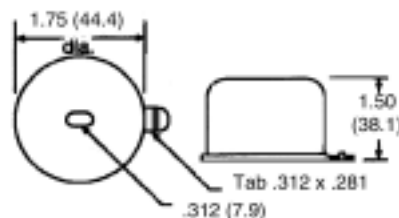

* UL File # for capacitors E133000(N)
 CSA File # for capacitors LR96263

UL File # for Boot SA6016(N)

Call **ebm Industries** at 860-674-1515 • Fax 860-674-8536 • E-mail: sales@ebm.com for Technical Assistance

© ebm Industries, Inc. 2001. ebm Industries, Inc. reserves the right to change any specifications or data without notice.



Компания «ЭлектроПласт» предлагает заключение долгосрочных отношений при поставках импортных электронных компонентов на взаимовыгодных условиях!

Наши преимущества:

- Оперативные поставки широкого спектра электронных компонентов отечественного и импортного производства напрямую от производителей и с крупнейших мировых складов;
- Поставка более 17-ти миллионов наименований электронных компонентов;
- Поставка сложных, дефицитных, либо снятых с производства позиций;
- Оперативные сроки поставки под заказ (от 5 рабочих дней);
- Экспресс доставка в любую точку России;
- Техническая поддержка проекта, помощь в подборе аналогов, поставка прототипов;
- Система менеджмента качества сертифицирована по Международному стандарту ISO 9001;
- Лицензия ФСБ на осуществление работ с использованием сведений, составляющих государственную тайну;
- Поставка специализированных компонентов (Xilinx, Altera, Analog Devices, Intersil, Interpoint, Microsemi, Aeroflex, Peregrine, Syfer, Eurofarad, Texas Instrument, Miteq, Cobham, E2V, MA-COM, Hittite, Mini-Circuits, General Dynamics и др.);

Помимо этого, одним из направлений компании «ЭлектроПласт» является направление «Источники питания». Мы предлагаем Вам помощь Конструкторского отдела:

- Подбор оптимального решения, техническое обоснование при выборе компонента;
- Подбор аналогов;
- Консультации по применению компонента;
- Поставка образцов и прототипов;
- Техническая поддержка проекта;
- Защита от снятия компонента с производства.



Как с нами связаться

Телефон: 8 (812) 309 58 32 (многоканальный)

Факс: 8 (812) 320-02-42

Электронная почта: org@eplast1.ru

Адрес: 198099, г. Санкт-Петербург, ул. Калинина, дом 2, корпус 4, литера А.