

# EH4600ETTS-30.720M

 <p><b>Lead Free</b> COMPLIANT</p>	 <p><b>EU RoHS</b> 2011/65 + 2015/863 COMPLIANT</p>	 <p><b>China RoHS</b> COMPLIANT</p>	 <p><b>REACH</b> SVHC 163 Jun 15, 2015 COMPLIANT</p>
--	--	--	---



## ITEM DESCRIPTION

Quartz Crystal Clock Oscillators XO (SPXO) LVCMOS (CMOS) 3.3Vdc 4 Pad 2.5mm x 3.2mm Ceramic Surface Mount (SMD) 30.720MHz  $\pm$ 100ppm -40°C to +85°C

## ELECTRICAL SPECIFICATIONS

<b>Nominal Frequency</b>	30.720MHz
<b>Frequency Tolerance/Stability</b>	$\pm$ 100ppm Maximum (Inclusive of all conditions: Calibration Tolerance at 25°C, Frequency Stability over the Operating Temperature Range, Supply Voltage Change, Output Load Change, First Year Aging at 25°, 260°C Reflow, Shock, and Vibration)
<b>Aging at 25°C</b>	$\pm$ 5ppm/Year Maximum
<b>Operating Temperature Range</b>	-40°C to +85°C
<b>Supply Voltage</b>	3.3Vdc $\pm$ 5%
<b>Input Current</b>	12mA Maximum (No Load)
<b>Output Voltage Logic High (Voh)</b>	90% of Vdd Minimum (IOH = -8mA)
<b>Output Voltage Logic Low (Vol)</b>	10% of Vdd Maximum (IOL = +8mA)
<b>Rise/Fall Time</b>	6nSec Maximum (Measured at 20% to 80% of waveform)
<b>Duty Cycle</b>	50 $\pm$ 10(%) (Measured at 50% of waveform)
<b>Load Drive Capability</b>	30pF Maximum
<b>Output Logic Type</b>	CMOS
<b>Pin 1 Connection</b>	Tri-State (High Impedance)
<b>Tri-State Input Voltage (Vih and Vil)</b>	90% of Vdd Minimum or No Connect to Enable Output, 10% of Vdd Maximum to Disable Output (High Impedance)
<b>Standby Current</b>	10 $\mu$ A Maximum (Pin 1 = Ground)
<b>RMS Phase Jitter</b>	20pSec Typical, 30pSec Maximum (Fj = 12kHz to 20MHz)
<b>Period Jitter (RMS)</b>	10pSec Typical
<b>Period Jitter (pk-pk)</b>	60pSec Typical, 100pSec Maximum
<b>Start Up Time</b>	10mSec Maximum
<b>Storage Temperature Range</b>	-55°C to +125°C

## ENVIRONMENTAL & MECHANICAL SPECIFICATIONS

<b>ESD Susceptibility</b>	MIL-STD-883, Method 3015, Class 1, HBM: 1500Vdc
<b>Fine Leak Test</b>	MIL-STD-883, Method 1014, Condition A
<b>Flammability</b>	UL94-V0
<b>Gross Leak Test</b>	MIL-STD-883, Method 1014, Condition C
<b>Mechanical Shock</b>	MIL-STD-883, Method 2002, Condition B
<b>Moisture Resistance</b>	MIL-STD-883, Method 1004
<b>Moisture Sensitivity</b>	J-STD-020, MSL 1
<b>Resistance to Soldering Heat</b>	MIL-STD-202, Method 210, Condition K
<b>Resistance to Solvents</b>	MIL-STD-202, Method 215
<b>Solderability</b>	MIL-STD-883, Method 2003
<b>Temperature Cycling</b>	MIL-STD-883, Method 1010, Condition B
<b>Vibration</b>	MIL-STD-883, Method 2007, Condition A

# EH4600ETTS-30.720M [↗](#)

## MECHANICAL DIMENSIONS (all dimensions in millimeters)

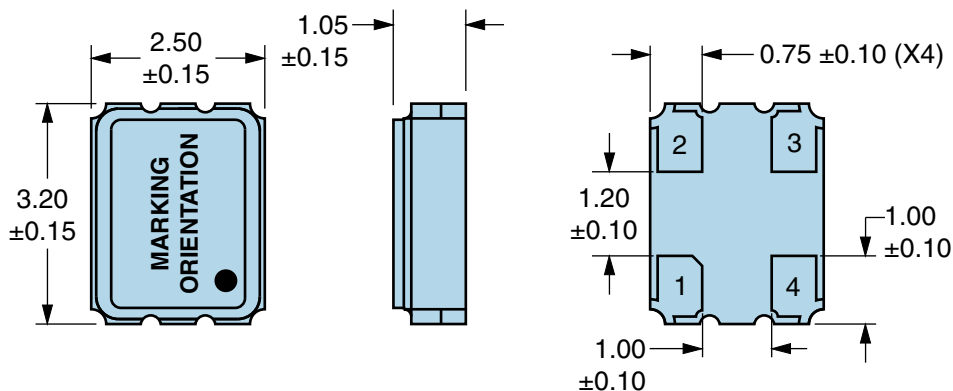

PIN	CONNECTION
1	Tri-State
2	Case Ground
3	Output
4	Supply Voltage

LINE	MARKING
1	<b>E30.720</b> <i>E=Ecliptek Designator</i>
2	<b>XXXXX</b> <i>XXXXX=Ecliptek Manufacturing Identifier</i>

## Suggested Solder Pad Layout

All Dimensions in Millimeters



All Tolerances are  $\pm 0.1$

# EH4600ETTS-30.720M [↗](#)

## OUTPUT WAVEFORM & TIMING DIAGRAM



# EH4600ETTS-30.720M [↗](#)

## Test Circuit for CMOS Output



Note 1: An external 0.01µF ceramic bypass capacitor in parallel with a 0.1µF high frequency ceramic bypass capacitor close (less than 2mm) to the package ground and supply voltage pin is required.

Note 2: A low capacitance (<12pF), 10X attenuation factor, high impedance (>10Mohms), and high bandwidth (>300MHz) passive probe is recommended.

Note 3: Capacitance value  $C_L$  includes sum of all probe and fixture capacitance.

# EH4600ETTS-30.720M [↗](#)

## Recommended Solder Reflow Methods



## High Temperature Infrared/Convection

$T_S$  MAX to  $T_L$  (Ramp-up Rate) 3°C/Second Maximum

### Preheat

- Temperature Minimum ( $T_S$  MIN) 150°C  
 - Temperature Typical ( $T_S$  TYP) 175°C  
 - Temperature Maximum ( $T_S$  MAX) 200°C  
 - Time ( $t_s$  MIN) 60 - 180 Seconds

Ramp-up Rate ( $T_L$  to  $T_P$ ) 3°C/Second Maximum

### Time Maintained Above:

- Temperature ( $T_L$ ) 217°C  
 - Time ( $t_L$ ) 60 - 150 Seconds

Peak Temperature ( $T_P$ ) 260°C Maximum for 10 Seconds Maximum

Target Peak Temperature ( $T_P$  Target) 250°C +0/-5°C

Time within 5°C of actual peak ( $t_p$ ) 20 - 40 Seconds

Ramp-down Rate 6°C/Second Maximum

Time 25°C to Peak Temperature (t) 8 Minutes Maximum

Moisture Sensitivity Level Level 1

Additional Notes Temperatures shown are applied to body of device.

# EH4600ETTS-30.720M [↗](#)

## Recommended Solder Reflow Methods



### Low Temperature Infrared/Convection 240°C

Ts MAX to TL (Ramp-up Rate) 5°C/Second Maximum

#### Preheat

- Temperature Minimum (Ts MIN) N/A  
 - Temperature Typical (Ts TYP) 150°C  
 - Temperature Maximum (Ts MAX) N/A  
 - Time (ts MIN) 60 - 120 Seconds

Ramp-up Rate (TL to TP) 5°C/Second Maximum

#### Time Maintained Above:

- Temperature (TL) 150°C  
 - Time (tL) 200 Seconds Maximum

Peak Temperature (TP) 240°C Maximum

Target Peak Temperature (TP Target) 240°C Maximum 2 Times / 230°C Maximum 1 Time

Time within 5°C of actual peak (tp) 10 Seconds Maximum 2 Times / 80 Seconds Maximum 1 Time

Ramp-down Rate 5°C/Second Maximum

Time 25°C to Peak Temperature (t) N/A

Moisture Sensitivity Level Level 1

Additional Notes Temperatures shown are applied to body of device.

### Low Temperature Manual Soldering

185°C Maximum for 10 Seconds Maximum, 2 times Maximum. (Temperatures shown are applied to body of device.)

### High Temperature Manual Soldering

260°C Maximum for 5 Seconds Maximum, 2 times Maximum. (Temperatures shown are applied to body of device.)

# Mouser Electronics

Authorized Distributor

Click to View Pricing, Inventory, Delivery & Lifecycle Information:

[Ecliptek:](#)

[EH4600ETTS-30.720M](#)



Компания «ЭлектроПласт» предлагает заключение долгосрочных отношений при поставках импортных электронных компонентов на взаимовыгодных условиях!

Наши преимущества:

- Оперативные поставки широкого спектра электронных компонентов отечественного и импортного производства напрямую от производителей и с крупнейших мировых складов;
- Поставка более 17-ти миллионов наименований электронных компонентов;
- Поставка сложных, дефицитных, либо снятых с производства позиций;
- Оперативные сроки поставки под заказ (от 5 рабочих дней);
- Экспресс доставка в любую точку России;
- Техническая поддержка проекта, помощь в подборе аналогов, поставка прототипов;
- Система менеджмента качества сертифицирована по Международному стандарту ISO 9001;
- Лицензия ФСБ на осуществление работ с использованием сведений, составляющих государственную тайну;
- Поставка специализированных компонентов (Xilinx, Altera, Analog Devices, Intersil, Interpoint, Microsemi, Aeroflex, Peregrine, Syfer, Eurofarad, Texas Instrument, Miteq, Cobham, E2V, MA-COM, Hittite, Mini-Circuits, General Dynamics и др.);

Помимо этого, одним из направлений компании «ЭлектроПласт» является направление «Источники питания». Мы предлагаем Вам помощь Конструкторского отдела:

- Подбор оптимального решения, техническое обоснование при выборе компонента;
- Подбор аналогов;
- Консультации по применению компонента;
- Поставка образцов и прототипов;
- Техническая поддержка проекта;
- Защита от снятия компонента с производства.



#### Как с нами связаться

**Телефон:** 8 (812) 309 58 32 (многоканальный)

**Факс:** 8 (812) 320-02-42

**Электронная почта:** [org@eplast1.ru](mailto:org@eplast1.ru)

**Адрес:** 198099, г. Санкт-Петербург, ул. Калинина, дом 2, корпус 4, литера А.