

Installation Instructions for the 26PC Series Pressure Sensors

ISSUE 4

PK 80083

⚠ WARNING

PERSONAL INJURY

DO NOT USE these products as safety or emergency stop devices, or in any other application where failure of the product could result in personal injury.

Failure to comply with these instructions could result in death or serious injury.

GENERAL INFORMATION

26PC Series pressure sensors are four active element piezoresistive bridges. When pressure is applied, the resistance changes and the 26PC provides an output signal proportional to the input pressure.

Gage pressure is measured with respect to ambient pressure. When applied pressure increases, the differential voltage $V_2 - V_4$ increases. As pressure decreases, differential voltage $V_2 - V_4$ decreases.

Differential sensors provide a differential voltage proportional to the pressure differential between port P2 and P1. As $DP = P_2 - P_1$ increases, differential voltage $V_2 - V_4$ increases. As $DP = P_2 - P_1$ decreases, differential voltage $V_2 - V_4$ decreases.

SOLDERING

Limit soldering to 315 °C [600 °F] maximum, with duration of 10 seconds maximum.

CLEANING

Proper cleaning fluids should be selected, based on the type of contaminants to be removed. Honeywell recommends alcohols or fluorinated solvents. Do not immerse the sensor.

26PC SERIES PERFORMANCE CHARACTERISTICS at 10.0 ± 0.01 Vdc Excitation, 25 °C

	Min.	Typ.	Max.	Units
Excitation	—	10	16	Vdc
Response Time	—	—	1.0	ms
Input Resistance*	5.5 k	7.5 k	11.5 k	Ohm
Output Resistance*	1.5 k	2.5 k	3.0 k	Ohm
Weight		2		gram

* Measured using a 1 mA current

ENVIRONMENTAL SPECIFICATIONS

Operating Temperature	-40 °C to 85 °C [-40 °F to 185 °F]
Storage Temperature	-55 °C to 100 °C [-67 °F to 212 °F]
Compensated Temperature	0 °C to 50 °C [32 °F to 122 °F]
Shock	Qualification tested to 150 g
Vibration	MIL-STD-202, Method 213 (0 kHz to 2 kHz, 20 G sine)

Note: For media compatibility specifications, refer to catalog or web site: www.honeywell.com/sensing

26PC CIRCUIT TERMINATION

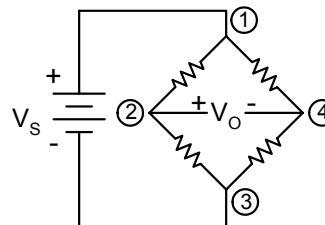

Pin 1 = V_s (+)

Pin 2 = Output + (V_2)

Pin 1 is notched

Pin 2 is next to Pin 1, etc.

Pin 4 = Output - (V_4)

Pin 3 = Ground (-)

26PC LASER BRANDING SCHEME (Note: Alternate form is the entire catalog listing)

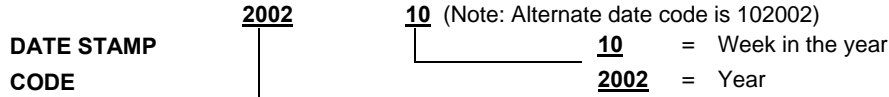
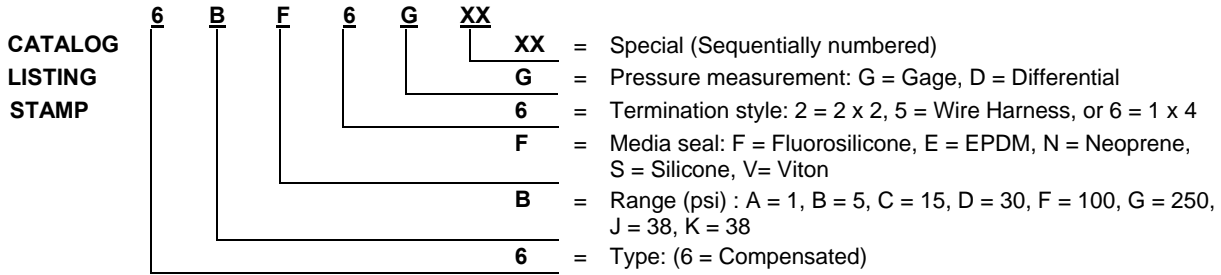

ADDITIONAL PORT VARIATIONS (dimensions for reference only) mm/in

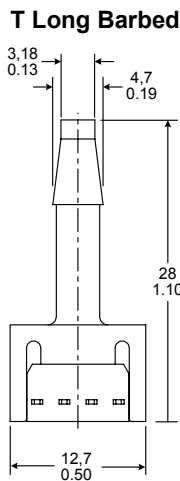
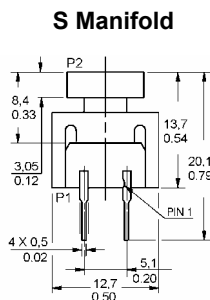
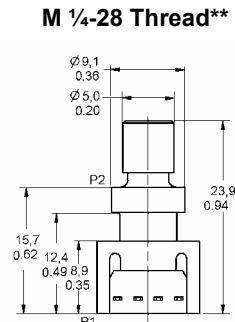
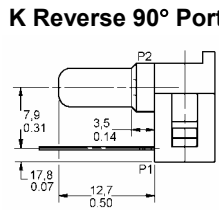
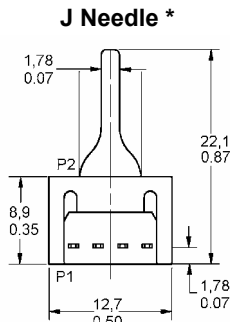
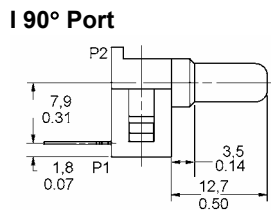
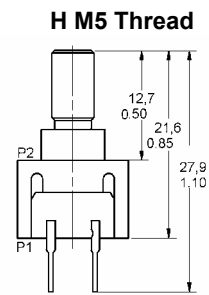
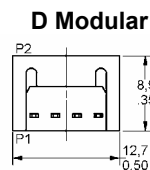
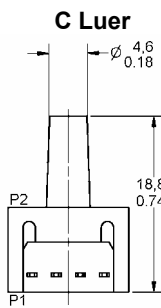
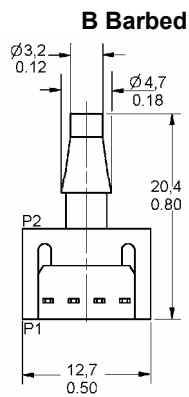

* Recommended torque for sealing is 4 in-lb. Do not exceed 6 in-lb of torque. Use size 007 O-Ring. O-Ring counterbore dimensions are 0.04 ± .005 in D x 0.300 ± .003 in Dia.

** Recommended torque for sealing is 8 in-lb. Do not exceed 12 in-lb. Use size 009 O-Ring. O-Ring counterbore dimensions are .040 ± .002 in D x 0.360 ± .003 in Dia.

ADDITIONAL PORT VARIATIONS (dimensions for reference only) mm/in

G Small Flow Through

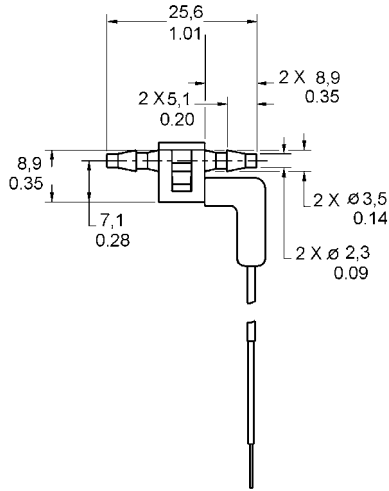

N or U Large Flow Through

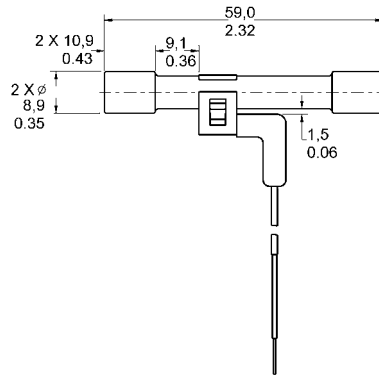

MOUNTING DIMENSIONS (dimensions for reference only) mm/in

GAGE SENSOR

1 x 4 Termination (Style 6) Port Style A, Straight

Pin 1 is notched, Pin 2 is next to Pin 1, etc.

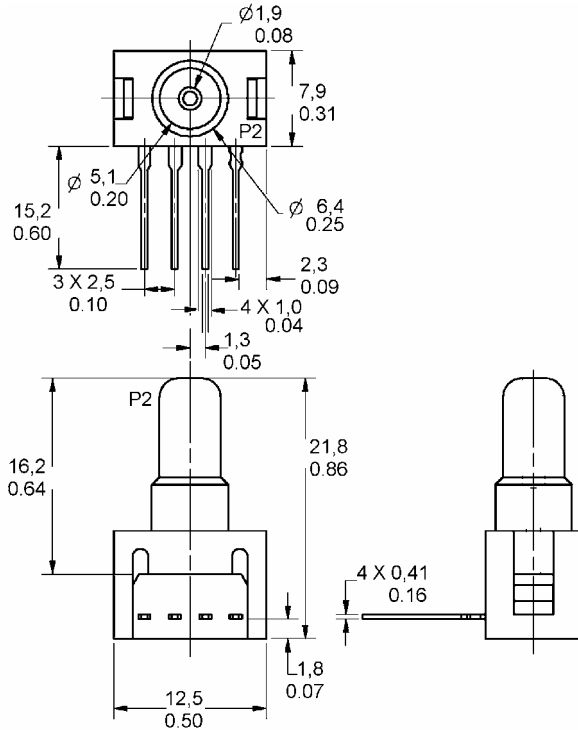

2 x 2 Termination (Style 2) Port Style A, Straight

Pin 1 is notched, Pin 1 is shown at lower right corner. Pins 2, 3, 4 are clockwise.

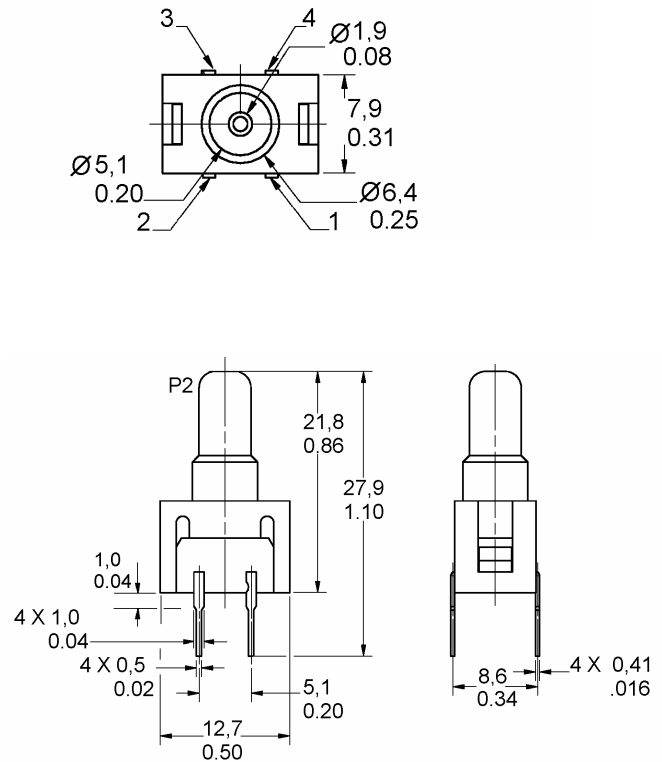

MOUNTING DIMENSIONS (for reference only) mm/in
DIFFERENTIAL SENSOR
1 X 4 Termination (Style 6) Port Style A, Straight (Only)

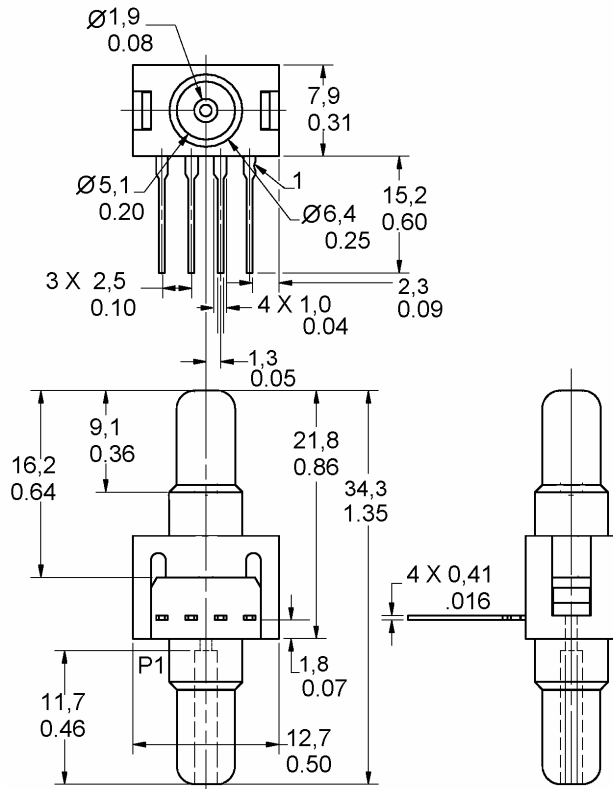

ACCESSORY
PC-10182 — Steel Lockring

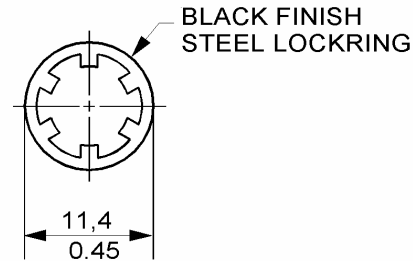

WARRANTY/REMEDY

Honeywell warrants goods of its manufacture as being free of defective materials and faulty workmanship. Contact your local sales office for warranty information. If warranted goods are returned to Honeywell during the period of coverage, Honeywell will repair or replace without charge those items it finds defective. The foregoing is Buyer's sole remedy and is **in lieu of all other warranties, expressed or implied, including those of merchantability and fitness for a particular purpose.**

Specifications may change without notice. The information we supply is believed to be accurate and reliable as of this printing. However, we assume no responsibility for its use.

While we provide application assistance personally, through our literature and the Honeywell web site, it is up to the customer to determine the suitability of the product in the application.

For application assistance, current specifications, or name of the nearest Authorized Distributor, contact a nearby sales office. Or call:

1-800-537-6945 USA
 1-800-737-3360 Canada
 1-815-235-6847 International

FAX

1-815-235-6545 USA

INTERNET

www.honeywell.com/sensing
info.sc@honeywell.com

Honeywell



Компания «ЭлектроПласт» предлагает заключение долгосрочных отношений при поставках импортных электронных компонентов на взаимовыгодных условиях!

Наши преимущества:

- Оперативные поставки широкого спектра электронных компонентов отечественного и импортного производства напрямую от производителей и с крупнейших мировых складов;
- Поставка более 17-ти миллионов наименований электронных компонентов;
- Поставка сложных, дефицитных, либо снятых с производства позиций;
- Оперативные сроки поставки под заказ (от 5 рабочих дней);
- Экспресс доставка в любую точку России;
- Техническая поддержка проекта, помощь в подборе аналогов, поставка прототипов;
- Система менеджмента качества сертифицирована по Международному стандарту ISO 9001;
- Лицензия ФСБ на осуществление работ с использованием сведений, составляющих государственную тайну;
- Поставка специализированных компонентов (Xilinx, Altera, Analog Devices, Intersil, Interpoint, Microsemi, Aeroflex, Peregrine, Syfer, Eurofarad, Texas Instrument, Miteq, Cobham, E2V, MA-COM, Hittite, Mini-Circuits, General Dynamics и др.);

Помимо этого, одним из направлений компании «ЭлектроПласт» является направление «Источники питания». Мы предлагаем Вам помощь Конструкторского отдела:

- Подбор оптимального решения, техническое обоснование при выборе компонента;
- Подбор аналогов;
- Консультации по применению компонента;
- Поставка образцов и прототипов;
- Техническая поддержка проекта;
- Защита от снятия компонента с производства.



Как с нами связаться

Телефон: 8 (812) 309 58 32 (многоканальный)

Факс: 8 (812) 320-02-42

Электронная почта: org@eplast1.ru

Адрес: 198099, г. Санкт-Петербург, ул. Калинина, дом 2, корпус 4, литера А.