

THIS DRAWING IS UNPUBLISHED. RELEASED FOR PUBLICATION
 © COPYRIGHT - By - ALL RIGHTS RESERVED.

REVISIONS					
P	LTR	DESCRIPTION	DATE	DWN	APVD
	P2	REVISED PER ECO-11-004587	11MAR11	RK	HMR
	R	REVISED PER ECO-17-002210	10APR2017	RS	MM

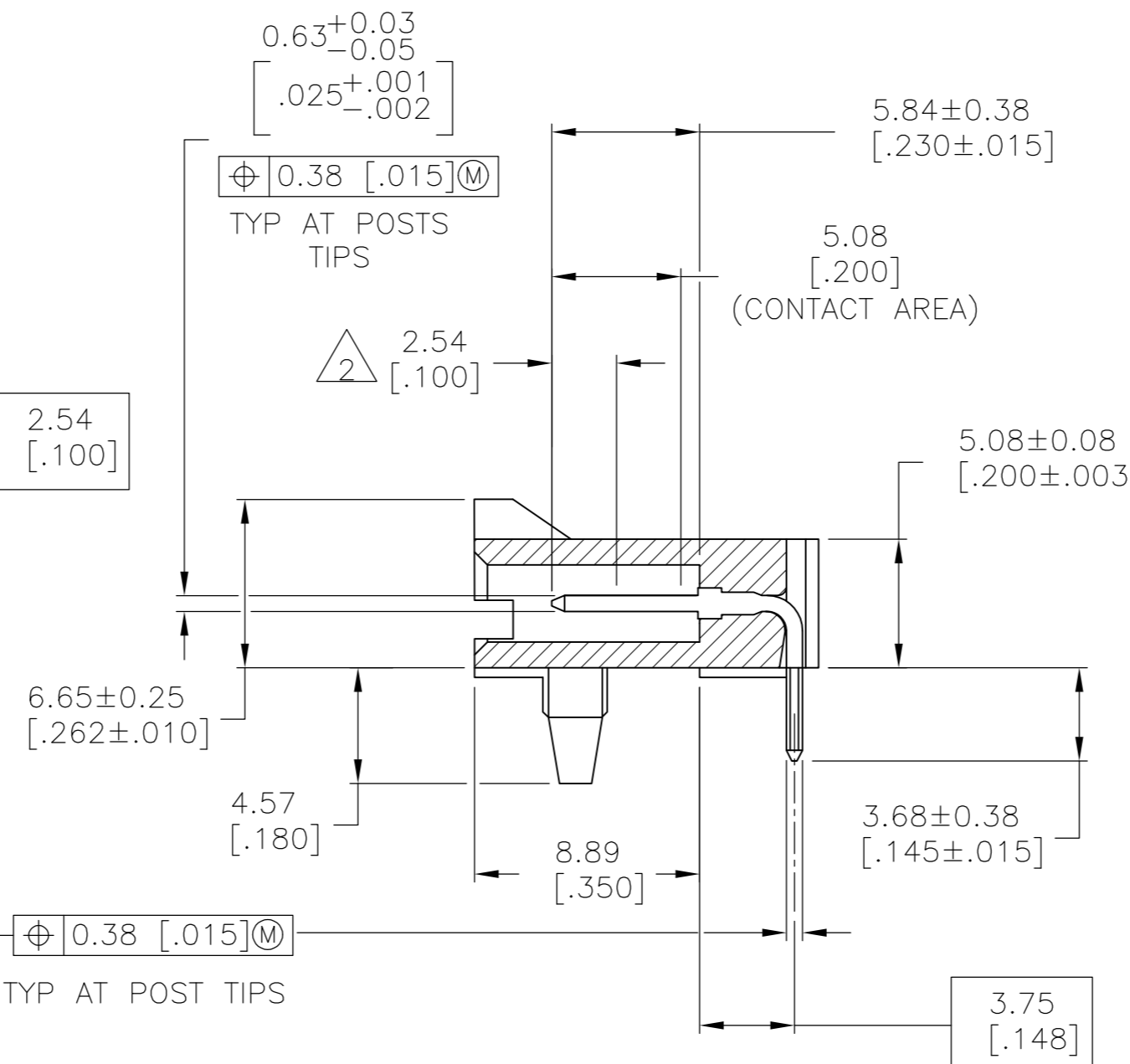

- 1 0.000381 [.000015] GOLD IN THE CONTACT AREA, 0.00254-0.00508 [.000100-.000200] MATTE TIN-LEAD ON THE SOLDER TAIL, ALL OVER 0.00127 [.000050] NICKEL.
- 2 POINT OF MEASUREMENT FOR PLATING THICKNESS
- 3 THE NOTED DIMENSIONS APPLY FROM THE BASIC DIMENSION LINE (NOT THE POST CENTERLINE) TO THE SURFACE INDICATED
- 4 ON ASSEMBLIES WITH FOUR OR MORE POSITIONS, TWO POLARIZATION SLOTS. ON ASSEMBLIES WITH TWO OR THREE POSITIONS, ONE POLARIZATION SLOT.
- 5 DIMENSIONS NOTED ARE FOR SOLDER STENCIL LAYOUT FOR USE WITH A 1.57±0.20 [.062±.008] THICK PRINTED CIRCUIT BOARD
- 6 PARTS ARE PACKAGED IN GANG OF TUBES
- 7 0.000381 [.000015] GOLD IN THE CONTACT AREA, 0.00254-0.00508 [.000100-.000200] MATTE TIN ON THE SOLDER TAIL, ALL OVER 0.00127 [.000050] NICKEL.
- 8 OBSOLETE PARTS: OBSOLETE CIS STREAMLINING PER D.RENAUD/D.SINISI

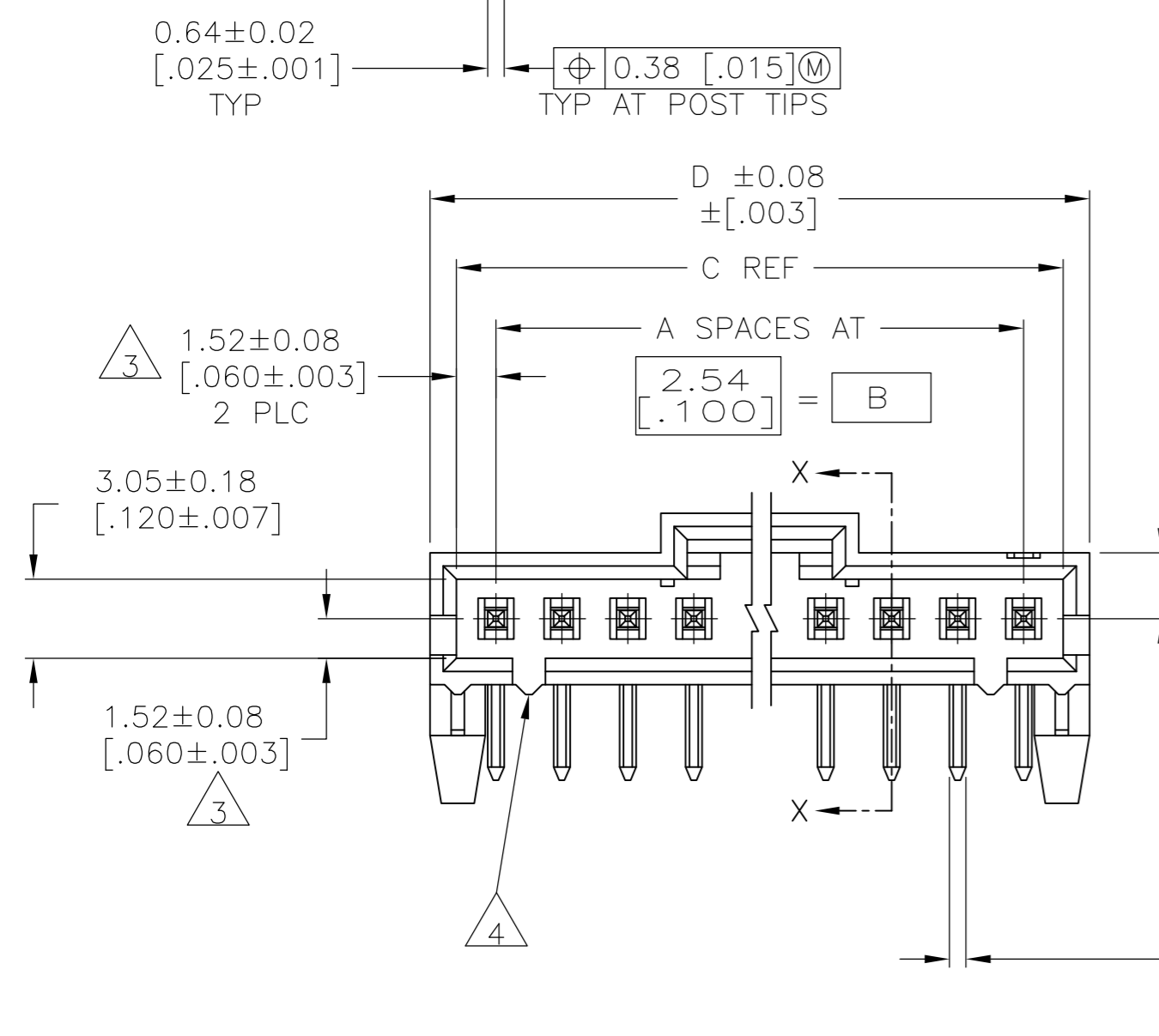
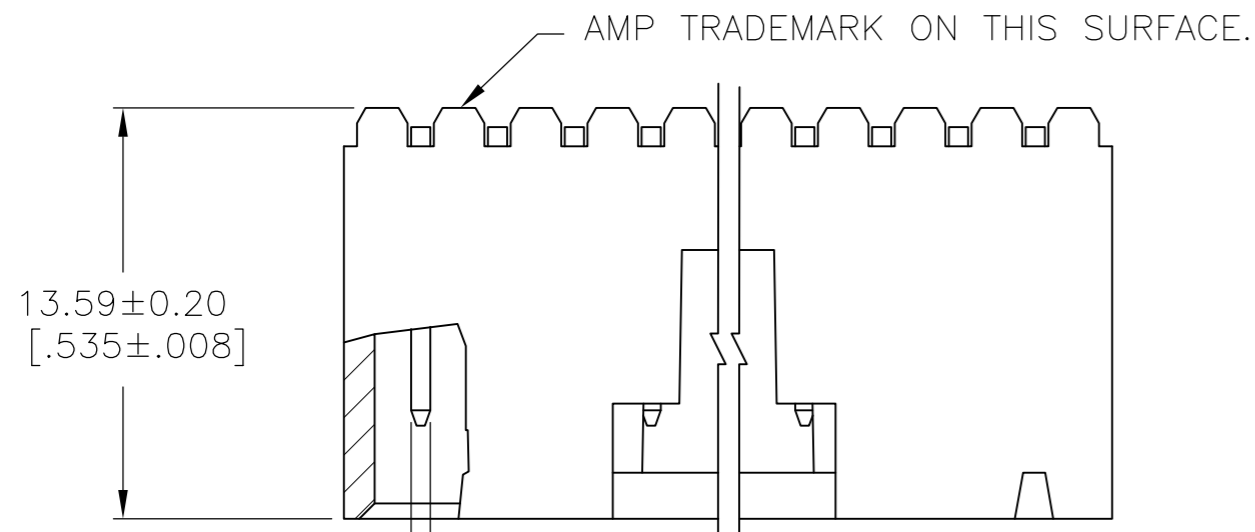
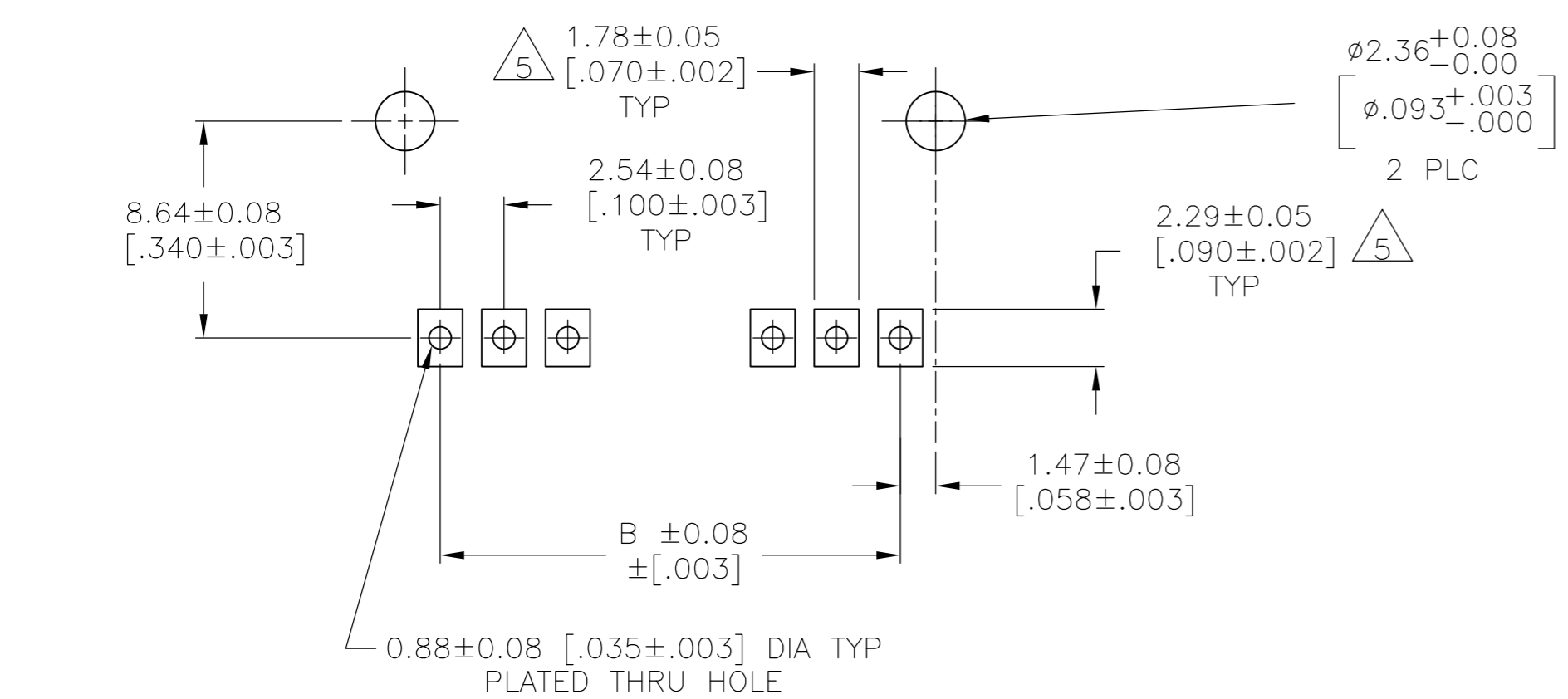

RECOMMENDED PC BOARD MOUNTING DIMENSIONS
 RECOMMENDED STENCIL THICKNESS = 0.25 [.010]

SEE SHEET 2 FOR PART NUMBER TABLE

THIS DRAWING IS A CONTROLLED DOCUMENT.		DWN 2-22-88 G DOUTY	TE Connectivity	
DIMENSIONS: mm [INCHES]		CHK 2-22-88 T C CLARK		
TOLERANCES UNLESS OTHERWISE SPECIFIED:		APVD 2-22-88 T C CLARK	NAME	
0 PLC ± -	1 PLC ± -	PRODUCT SPEC	HEADER ASSY, AMPMODU MTE, RIGHT ANGLE, SINGLE ROW, .100 POSTS, WITH LATCH & HOLD DOWNS	
2 PLC ± 0.13 [.005]	3 PLC ± -	APPLICATION SPEC	SIZE	RESTRICTED TO
4 PLC ± -	ANGLES ± -	FINISH	A2	
MATERIAL: HOUSING : LCP, COLOR : BLACK, POSTS : BRASS		WEIGHT -	CAGE CODE	DRAWING NO
SEE TABLE		CUSTOMER DRAWING	00779	104361
		SCALE 4:1	SHEET 1 OF 2	REV R

THIS DRAWING IS UNPUBLISHED. RELEASED FOR PUBLICATION
 © COPYRIGHT - By - ALL RIGHTS RESERVED.

REVISIONS					
P	LTR	DESCRIPTION	DATE	DWN	APVD
-	-	SEE SHEET 1	-	-	-

PLATING	D	C	B	A	NO OF POSN	ASSEMBLY PART NUMBER
	7	65.91 [2.595]	64.01 [2.520]	60.96 [2.400]	24 25	7-104361-4
	7	63.37 [2.495]	61.47 [2.420]	58.42 [2.300]	23 24	7-104361-3
	7	60.83 [2.395]	58.93 [2.320]	55.88 [2.200]	22 23	7-104361-2
	7	58.29 [2.295]	56.39 [2.220]	53.34 [2.100]	21 22	7-104361-1
	7	55.75 [2.195]	53.85 [2.120]	50.8 [2.000]	20 21	7-104361-0
	7	53.21 [2.095]	51.31 [2.020]	48.26 [1.900]	19 20	6-104361-9
	7	50.67 [1.995]	48.77 [1.920]	45.72 [1.800]	18 19	6-104361-8
	7	48.13 [1.895]	46.23 [1.820]	43.18 [1.700]	17 18	6-104361-7
	7	45.59 [1.795]	43.69 [1.720]	40.64 [1.600]	16 17	6-104361-6
	7	43.05 [1.695]	41.15 [1.620]	38.1 [1.500]	15 16	6-104361-5
	7	40.51 [1.595]	38.61 [1.520]	35.56 [1.400]	14 15	6-104361-4
	7	37.97 [1.495]	36.07 [1.420]	33.02 [1.300]	13 14	6-104361-3
	7	35.43 [1.395]	33.53 [1.320]	30.48 [1.200]	12 13	6-104361-2
	7	32.89 [1.295]	30.99 [1.220]	27.94 [1.100]	11 12	6-104361-1
	7	30.35 [1.195]	28.45 [1.120]	25.4 [1.000]	10 11	6-104361-0
	7	27.81 [1.095]	25.91 [1.020]	22.86 [.900]	9 10	5-104361-9
	7	25.27 [.995]	23.37 [.920]	20.32 [.800]	8 9	5-104361-8
	7	22.73 [.895]	20.83 [.820]	17.78 [.700]	7 8	5-104361-7
	7	20.19 [.795]	18.29 [.720]	15.24 [.600]	6 7	5-104361-6
	7	17.65 [.695]	15.75 [.620]	12.7 [.500]	5 6	5-104361-5
	7	15.11 [.595]	13.21 [.520]	10.16 [.400]	4 5	5-104361-4
	7	12.57 [.495]	10.67 [.420]	7.62 [.300]	3 4	5-104361-3
	7	10.03 [.395]	8.13 [.320]	5.08 [.200]	2 3	5-104361-2
	7	7.49 [.295]	5.59 [.220]	2.54 [.100]	1 2	5-104361-1
	1	65.91 [2.595]	64.01 [2.520]	60.96 [2.400]	24 25	2-104361-4
	1	63.37 [2.495]	61.47 [2.420]	58.42 [2.300]	23 24	2-104361-3
	1	60.83 [2.395]	58.93 [2.320]	55.88 [2.200]	22 23	2-104361-2
	1	58.29 [2.295]	56.39 [2.220]	53.34 [2.100]	21 22	2-104361-1
	1	55.75 [2.195]	53.85 [2.120]	50.8 [2.000]	20 21	2-104361-0
	1	53.21 [2.095]	51.31 [2.020]	48.26 [1.900]	19 20	1-104361-9
	1	50.67 [1.995]	48.77 [1.920]	45.72 [1.800]	18 19	1-104361-8
	1	48.13 [1.895]	46.23 [1.820]	43.18 [1.700]	17 18	1-104361-7
	1	45.59 [1.795]	43.69 [1.720]	40.64 [1.600]	16 17	1-104361-6
	1	43.05 [1.695]	41.15 [1.620]	38.1 [1.500]	15 16	1-104361-5
	1	40.51 [1.595]	38.61 [1.520]	35.56 [1.400]	14 15	1-104361-4
	1	37.97 [1.495]	36.07 [1.420]	33.02 [1.300]	13 14	1-104361-3
	1	35.43 [1.395]	33.53 [1.320]	30.48 [1.200]	12 13	1-104361-2
	1	32.89 [1.295]	30.99 [1.220]	27.94 [1.100]	11 12	1-104361-1
	1	30.35 [1.195]	28.45 [1.120]	25.4 [1.000]	10 11	1-104361-0
	1	27.81 [1.095]	25.91 [1.020]	22.86 [.900]	9 10	104361-9
	1	25.27 [.995]	23.37 [.920]	20.32 [.800]	8 9	104361-8
	1	22.73 [.895]	20.83 [.820]	17.78 [.700]	7 8	104361-7
	1	20.19 [.795]	18.29 [.720]	15.24 [.600]	6 7	104361-6
	1	17.65 [.695]	15.75 [.620]	12.7 [.500]	5 6	104361-5
	1	15.11 [.595]	13.21 [.520]	10.16 [.400]	4 5	104361-4
	1	12.57 [.495]	10.67 [.420]	7.62 [.300]	3 4	104361-3
	1	10.03 [.395]	8.13 [.320]	5.08 [.200]	2 3	104361-2
	1	7.49 [.295]	5.59 [.220]	2.54 [.100]	1 2	104361-1

△ SUPERSEDED BY 7-104361-4
 △ SUPERSEDED BY 7-104361-3
 △ SUPERSEDED BY 7-104361-2
 △ SUPERSEDED BY 7-104361-1
 △ SUPERSEDED BY 7-104361-0

 △ SUPERSEDED BY 6-104361-8
 △ SUPERSEDED BY 6-104361-7
 △ SUPERSEDED BY 6-104361-6
 △ SUPERSEDED BY 6-104361-5
 △ SUPERSEDED BY 6-104361-4

 △ SUPERSEDED BY 6-104361-2

 △ SUPERSEDED BY 6-104361-0

THIS DRAWING IS A CONTROLLED DOCUMENT.		DWN G DOUTY 2-22-88	 TE Connectivity			
DIMENSIONS: mm [INCHES]		CHK T C CLARK 2-22-88				
TOLERANCES UNLESS OTHERWISE SPECIFIED:		APVD T C CLARK 2-22-88	NAME			
0 PLC ± - 1 PLC ± - 2 PLC ± - 3 PLC ± - 4 PLC ± - ANGLES ± -		PRODUCT SPEC	HEADER ASSY, AMPMODU MTE, RIGHT ANGLE, SINGLE ROW, .100 POSTS, WITH LATCH & HOLD DOWNS			
MATERIAL HOUSING : LCP COLOR : BLACK POSTS : BRASS		APPLICATION SPEC	SIZE A2	CAGE CODE 00779	DRAWING NO C=104361	RESTRICTED TO
FINISH SEE TABLE		WEIGHT -	SCALE 4:1		SHEET 2 OF 2	REV R
CUSTOMER DRAWING						



Компания «ЭлектроПласт» предлагает заключение долгосрочных отношений при поставках импортных электронных компонентов на взаимовыгодных условиях!

Наши преимущества:

- Оперативные поставки широкого спектра электронных компонентов отечественного и импортного производства напрямую от производителей и с крупнейших мировых складов;
- Поставка более 17-ти миллионов наименований электронных компонентов;
- Поставка сложных, дефицитных, либо снятых с производства позиций;
- Оперативные сроки поставки под заказ (от 5 рабочих дней);
- Экспресс доставка в любую точку России;
- Техническая поддержка проекта, помощь в подборе аналогов, поставка прототипов;
- Система менеджмента качества сертифицирована по Международному стандарту ISO 9001;
- Лицензия ФСБ на осуществление работ с использованием сведений, составляющих государственную тайну;
- Поставка специализированных компонентов (Xilinx, Altera, Analog Devices, Intersil, Interpoint, Microsemi, Aeroflex, Peregrine, Syfer, Eurofarad, Texas Instrument, Miteq, Cobham, E2V, MA-COM, Hittite, Mini-Circuits, General Dynamics и др.);

Помимо этого, одним из направлений компании «ЭлектроПласт» является направление «Источники питания». Мы предлагаем Вам помощь Конструкторского отдела:

- Подбор оптимального решения, техническое обоснование при выборе компонента;
- Подбор аналогов;
- Консультации по применению компонента;
- Поставка образцов и прототипов;
- Техническая поддержка проекта;
- Защита от снятия компонента с производства.



Как с нами связаться

Телефон: 8 (812) 309 58 32 (многоканальный)

Факс: 8 (812) 320-02-42

Электронная почта: org@eplast1.ru

Адрес: 198099, г. Санкт-Петербург, ул. Калинина, дом 2, корпус 4, литера А.