



LITE-ON TECHNOLOGY CORPORATION

Property of Lite-On Only

LED LAMP

LTL3H3TGUADS1-132A

DATA SHEET FOR

CUSTOMER: RGB SIGN

Part No.	Lens	Source Color
LTL3H3TGUADS1-132A	Green Diffused	InGaN Green

PREPARED BY ENG : Nedphaka	APPROVED OF PD : Brian Su	PREPARED DATE : Feb./21, 2013	REV : A
--------------------------------------	-------------------------------------	---	-------------------

Features

- * High Luminous intensity output.
- * Low power consumption.
- * High efficiency.
- * Wide Viewing Angle
Major Axis 100° / Minor Axis 45°
- * Versatile mounting on P.C. board or panel.
- * I.C. Compatible/low current requirements.

Package Dimensions

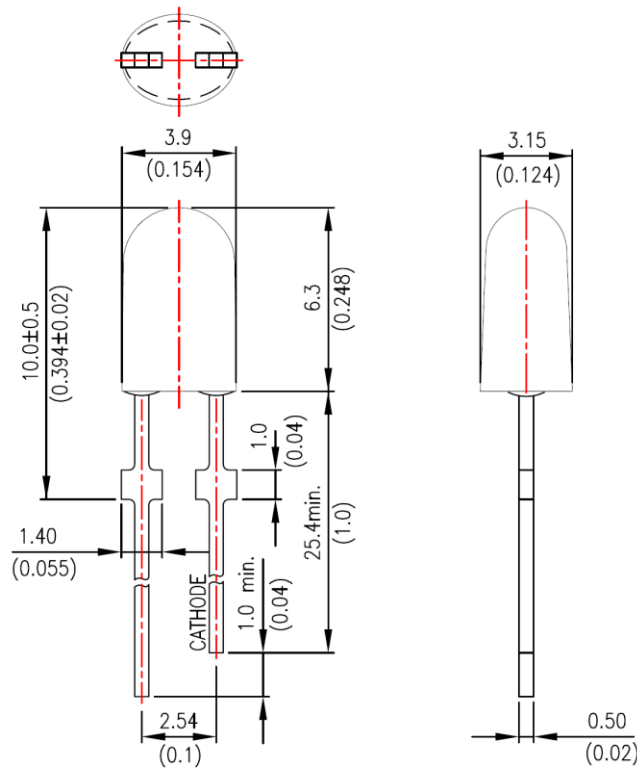

Part No.	Lens	Source Color
LTL3H3TGUADS1	Green Diffused	InGaN Green

Notes:

1. All dimensions are in millimeters (inches).
2. Tolerance is ±0.25mm(.010") unless otherwise noted.
3. Protruded resin under flange is 1.0mm(.04") max.
4. Lead spacing is measured where the leads emerge from the package.
5. Specifications are subject to change without notice.



Absolute Maximum Ratings at $T_A=25^\circ\text{C}$

Parameter	Maximum Rating	Unit
Power Dissipation	110	mW
Peak Forward Current (Duty Cycle $\leq 1/10$, Pulse Width $\leq 10\text{ms}$)	90	mA
DC Forward Current	30	mA
Derating Linear From 40°C	0.56	mA/ $^\circ\text{C}$
Reverse Voltage	5	V
Operating Temperature Range	-30°C to $+85^\circ\text{C}$	
Storage Temperature Range	-40°C to $+100^\circ\text{C}$	
Lead Soldering Temperature [2.0mm (.079") From Body]	260 $^\circ\text{C}$ for 5 Seconds Max.	

Electrical / Optical Characteristics at T_A=25°C

Parameter	Symbol	Min.	Typ.	Max.	Unit	Test Condition
Luminous Intensity	I _v	2900	3800	5000	mcd	I _F = 20mA Note 1,5
Viewing Angle	2θ _{1/2}		100 / 45		deg	Note 2 (Fig.6)
Peak Emission Wavelength	λ _p		520		nm	Measurement @Peak (Fig.1)
Dominant Wavelength	λ _d	525	528	532	nm	Note 4
Spectral Line Half-Width	Δλ		30		nm	
Forward Voltage	V _F	2.6	3.2	3.7	V	I _F = 20mA
Reverse Current	I _R			50	μA	V _R = 5V

NOTE: 1. Luminous intensity is measured with a light sensor and filter combination that approximates the CIE eye-response curve.

2. θ_{1/2} is the off-axis angle at which the luminous intensity is half the axial luminous intensity.

3. I_v classification code is marked on each packing bag.

4. The dominant wavelength, λ_d is derived from the CIE chromaticity diagram and represents the single wavelength which defines the color of the device.

5. I_v guarantee must be included with ±15% testing tolerance.

6. Reverse voltage (V_R) condition is applied for I_R test only. The device is not designed for reverse operation.

Property of Lite-On Only

Typical Electrical / Optical Characteristics Curves

(25°C Ambient Temperature Unless Otherwise Noted)

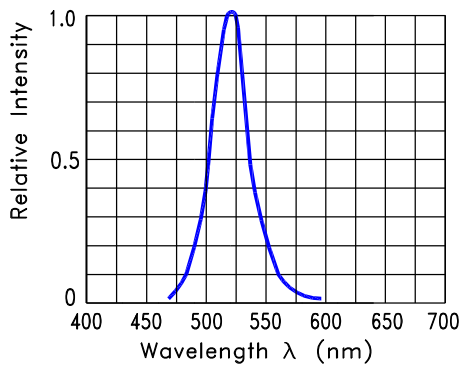

Fig.1 Relative Intensity VS. Wavelength

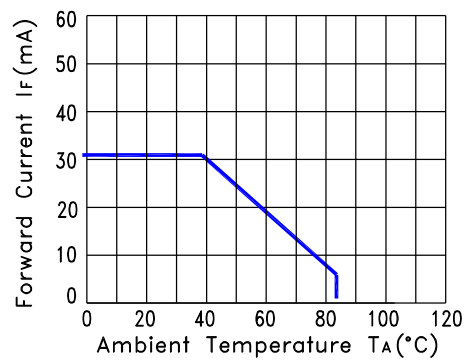

Fig.2 Forward Current Derating Curve

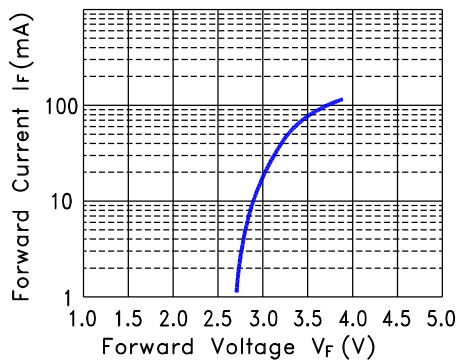

Fig.3 Forward Current vs. Forward Voltage

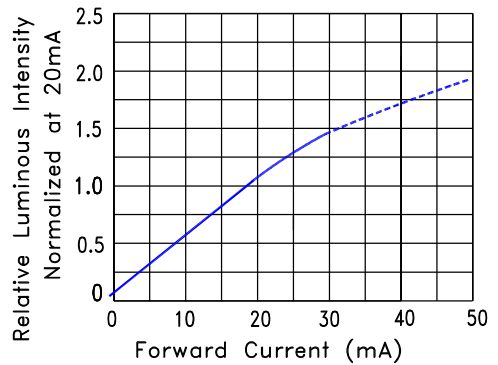

Fig.4 Relative Luminous Intensity vs. Forward Current

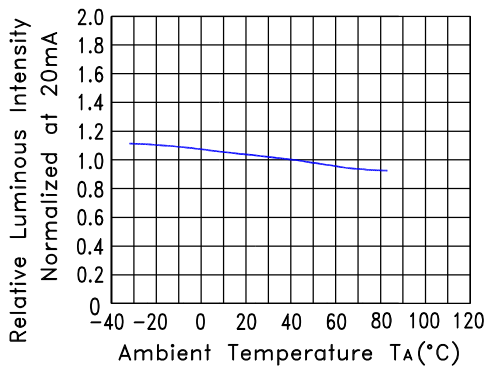

Fig.5 Relative Luminous Intensity VS. Ambient Temperature

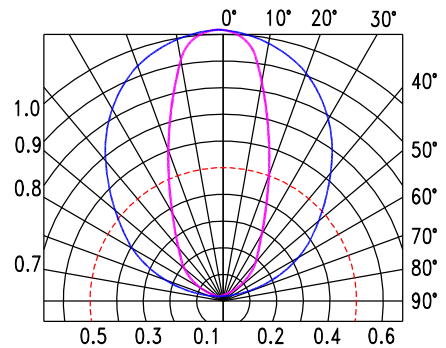
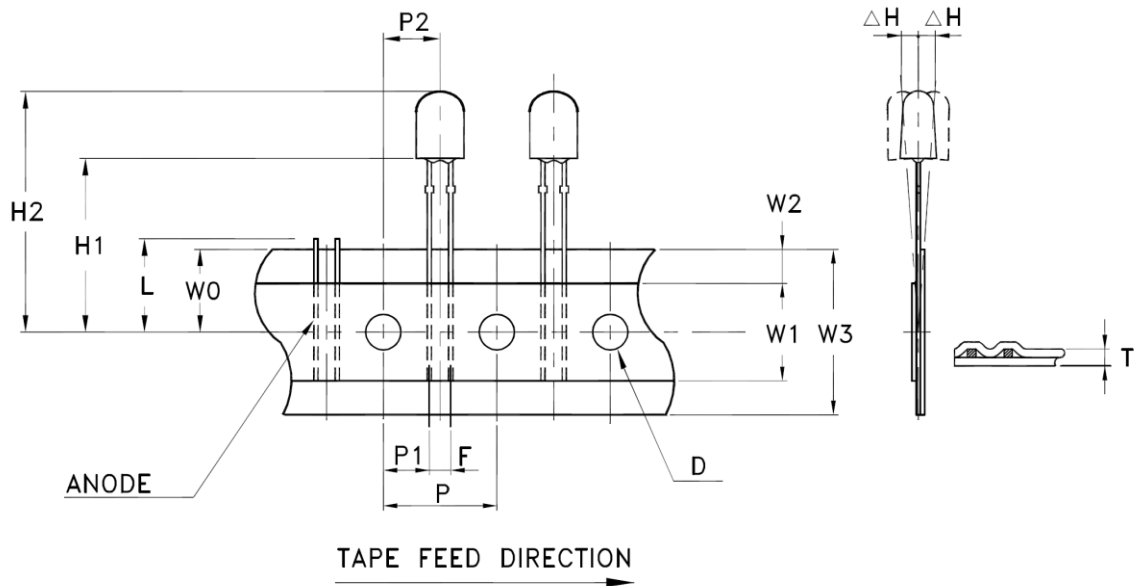

Fig.6 Spatial Distribution

Features

- * Compatible with radial lead automatic insertion equipment.
 - * Most radial lead plastic lead lamps available packaged in tape and folding.
 - * 2.54mm (0.1") straight lead spacing available.
 - * Folding packaging simplifies handling and testing.
- Reel packaging is available by removing suffix "A" on option.

Package Dimensions



Item	Symbol	Specification			
		Minimum		Maximum	
		mm	inch	mm	inch
Tape Feed Hole Diameter	D	3.8	0.149	4.2	0.165
Component Lead Pitch	F	2.3	0.091	3.0	0.118
Front to Rear Deflection	ΔH	--	--	2.0	0.078
Feed Hole to Bottom of Component	H1	20.0	0.787	21.0	0.827
Feed Hole to Overall Component Height	H2	25.9	1.020	27.5	1.083
Lead Length After Component Height	L	W0		11.0	0.433
Feed Hole Pitch	P	12.4	0.488	13.0	0.511
Lead Location	P1	4.4	0.173	5.8	0.228
Center of Component Location	P2	5.05	0.198	7.65	0.301
Total Tape Thickness	T	--	--	0.90	0.035
Feed Hole Location	W0	8.5	0.334	9.75	0.384
Adhesive Tape Position	W2	0	0	3.0	0.118
Tape Width	W3	17.5	0.689	19.0	0.748

Property of Lite-On Only

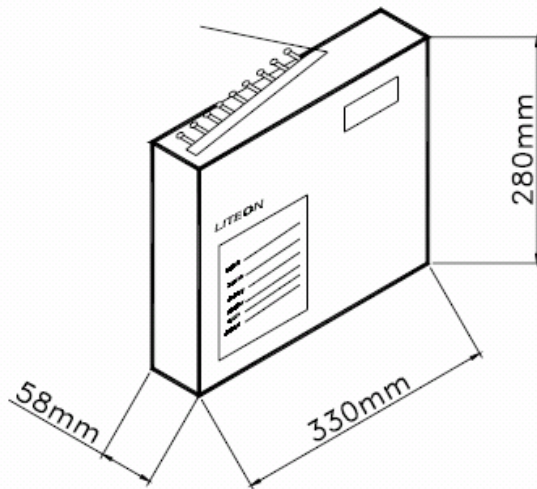
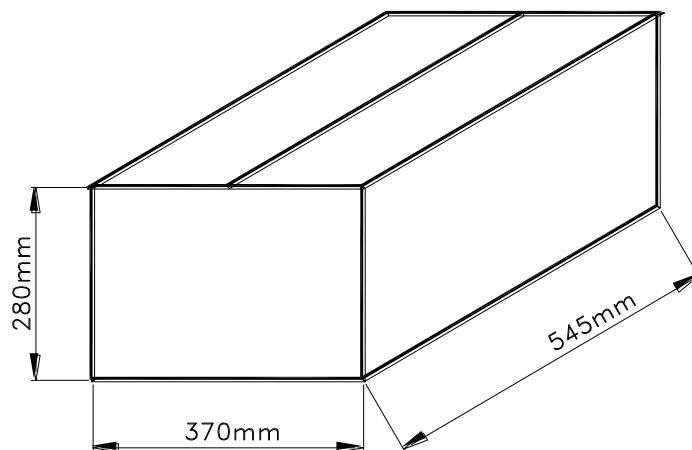
Packing Spec**Total 2,500pcs per inner carton**Tolerance: $\pm 5\text{mm}$ **10 Inner cartons per outer carton****total 25,000 pcs per outer carton****In every shipping lot, only the last pack will be non-full packing**



Bin Table Specification

Luminous Intensity Iv(mcd)		IF@20mA
Bin Code	Min.	Max.
G1	2900	3800
G2	3800	5000

Note: Tolerance of each bin limit is $\pm 15\%$

Dominant Wavelength		Unit : nm @20mA
Bin Code	Bin Code	Bin Code
GH1	525.0	528.5
GH2	528.5	532.0

Note: Tolerance of each bin limit is $\pm 1\text{nm}$



CAUTIONS

1. Application

This LED lamp is good for application of indoor and outdoor sign, also ordinary electronic equipment.

2. Storage

The storage ambient for the LEDs should not exceed 30°C temperature or 70% relative humidity. It is recommended that LEDs out of their original packaging are used within three months. For extended storage out of their original packaging, it is recommended that the LEDs be stored in a sealed container with appropriate desiccant or in desiccators with nitrogen ambient.

3. Cleaning

Use alcohol-based cleaning solvents such as isopropyl alcohol to clean the LEDs if necessary.

4. Lead Forming & Assembly

During lead forming, the leads should be bent at a point at least 3mm from the base of LED lens. Do not use the base of the lead frame as a fulcrum during forming. Lead forming must be done before soldering, at normal temperature. During assembly on PCB, use minimum clinch force possible to avoid excessive mechanical stress.

5. Soldering

When soldering, leave a minimum of 3mm clearance from the base of the lens to the soldering point. Dipping the lens into the solder must be avoided. Do not apply any external stress to the lead frame during soldering while the LED is at high temperature. Recommended soldering conditions :

Table with 2 columns: Soldering iron and Wave soldering. Rows include Temperature, Soldering time, and Position.

Note: Excessive soldering temperature and/or time might result in deformation of the LED lens or catastrophic failure of the LED. IR reflow is not suitable process for through hole type LED lamp product.

6. Drive Method

An LED is a current-operated device. In order to ensure intensity uniformity on multiple LEDs connected in parallel in an application, it is recommended that a current limiting resistor be incorporated in the drive circuit, in series with each LED as shown in Circuit A below.

Circuit model A

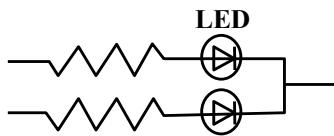

Circuit model B

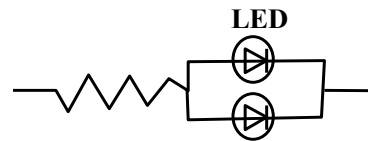

(A) Recommended circuit

(B) The brightness of each LED might appear different due to the differences in the I-V characteristics of those LEDs

7. ESD (Electrostatic Discharge)

Static Electricity or power surge will damage the LED.

Suggestions to prevent ESD damage:

- Use a conductive wrist band or anti- electrostatic glove when handling these LEDs
- All devices, equipment, and machinery must be properly grounded
- Work tables, storage racks, etc. should be properly grounded
- Use ion blower to neutralize the static charge which might have built up on surface of the LEDs plastic lens as a result of friction between LEDs during storage and handing



Suggested checking list :

Training and Certification

1. Everyone working in a static-safe area is ESD-certified?
2. Training records kept and re-certification dates monitored?

Static-Safe Workstation & Work Areas

1. Static-safe workstation or work-areas have ESD signs?
2. All surfaces and objects at all static-safe workstation and within 1 ft measure less than 100V?
3. All ionizer activated, positioned towards the units?
4. Each work surface mats grounding is good?

Personnel Grounding

1. Every person (including visitors) handling ESD sensitive (ESDS) items wear wrist strap, heel strap or conductive shoes with conductive flooring?
2. If conductive footwear used, conductive flooring also present where operator stand or walk?
3. Garments, hairs or anything closer than 1 ft to ESD items measure less than 100V*?
4. Every wrist strap or heel strap/conductive shoes checked daily and result recorded for all DLs?
5. All wrist strap or heel strap checkers calibration up to date?

Note: *50V for Blue LED.

Device Handling

1. Every ESDS items identified by EIA-471 labels on item or packaging?
2. All ESDS items completely inside properly closed static-shielding containers when not at static-safe workstation?
3. No static charge generators (e.g. plastics) inside shielding containers with ESDS items?
4. All flexible conductive and dissipative package materials inspected before reuse or recycle?

Others

1. Audit result reported to entity ESD control coordinator?
2. Corrective action from previous audits completed?
3. Are audit records complete and on file?



LITE-ON TECHNOLOGY CORPORATION

Property of Lite-On Only

8. Reliability Test

Classification	Test Item	Test Condition	Sample Size	Reference Standard
Endurance Test	Operation Life	Ta = 25°C IF = 30mA *Test Time= 1000hrs	45 PCS (CL=90%; LTPD=5%)	MIL-STD-750D:1026 (1995) MIL-STD-883G:1005 (2006)
	High Temperature/ High Humidity storage (THB)	Ta = 85°C RH = 85% *Test Time= 1000hrs	45 PCS (CL=90%; LTPD=5%)	MIL-STD-202G:103B (2002) JEITA ED-4701:100 103 (2001)
	Steady state Operation Life of High Humidity Heat	Ta = 85°C, RH= 85 % IF = 10mA *Test Time= 500hrs	76 PCS (CL=90%; LTPD=3%)	JESD22-A101C (2009)
	Low Temperature Operation Life of	Ta = -30°C IF = 30mA *Test Time= 1000hrs	45 PCS (CL=90%; LTPD=5%)	
	High Temperature Storage	Ta= 105 ± 5°C *Test Time= 1000hrs	45 PCS (CL=90%; LTPD=5%)	MIL-STD-750D:1031 (1995) MIL-STD-883G:1008 (2006) JEITA ED-4701:200 201 (2001)
	Low Temperature Storage	Ta= -55 ± 5°C *Test Time= 1000hrs	45 PCS (CL=90%; LTPD=5%)	JEITA ED-4701:200 202 (2001)
	Environmental Test	Temperature Cycling	100°C ~ 25°C ~ -40°C ~ 25°C 30mins 5mins 30mins 5mins *Test time: 200 Cycles	76 PCS (CL=90%; LTPD=3%)
Thermal Shock		100 ± 5°C ~ -30°C ± 5°C 15mins 15mins *Test time: 200 Cycles (<20 secs transfer)	76 PCS (CL=90%; LTPD=3%)	MIL-STD-750D:1056 (1995) MIL-STD-883G:1011 (2006) MIL-STD-202G:107G (2002) JESD22-A106B (2004)
Solder Resistance		T.sol = 260 ± 5°C Dwell Time= 10±1 seconds 3mm from the base of the epoxy bulb	11 PCS (CL=90%; LTPD=18.9%)	MIL-STD-750D:2031(1995) JEITA ED-4701: 300 302 (2001)
Solderability		T. sol = 245 ± 5°C Dwell Time= 5 ± 0.5 seconds (Lead Free Solder, Coverage ≥ 95% of the dipped surface)	11 PCS (CL=90%; LTPD=18.9%)	MIL-STD-750D:2026 (1995) MIL-STD-883G:2003 (2006) MIL-STD-202G:208H (2002) IPC/EIA J-STD-002 (2004)
Soldering Iron		T. sol = 350 ± 5°C Dwell Time= 3.5 ± 0.5 seconds	11 PCS (CL=90%;LTPD =18.9%)	MIL-STD-202G:208H (2002) JEITA ED-4701:300 302 (2001)



Компания «ЭлектроПласт» предлагает заключение долгосрочных отношений при поставках импортных электронных компонентов на взаимовыгодных условиях!

Наши преимущества:

- Оперативные поставки широкого спектра электронных компонентов отечественного и импортного производства напрямую от производителей и с крупнейших мировых складов;
- Поставка более 17-ти миллионов наименований электронных компонентов;
- Поставка сложных, дефицитных, либо снятых с производства позиций;
- Оперативные сроки поставки под заказ (от 5 рабочих дней);
- Экспресс доставка в любую точку России;
- Техническая поддержка проекта, помощь в подборе аналогов, поставка прототипов;
- Система менеджмента качества сертифицирована по Международному стандарту ISO 9001;
- Лицензия ФСБ на осуществление работ с использованием сведений, составляющих государственную тайну;
- Поставка специализированных компонентов (Xilinx, Altera, Analog Devices, Intersil, Interpoint, Microsemi, Aeroflex, Peregrine, Syfer, Eurofarad, Texas Instrument, Miteq, Cobham, E2V, MA-COM, Hittite, Mini-Circuits, General Dynamics и др.);

Помимо этого, одним из направлений компании «ЭлектроПласт» является направление «Источники питания». Мы предлагаем Вам помощь Конструкторского отдела:

- Подбор оптимального решения, техническое обоснование при выборе компонента;
- Подбор аналогов;
- Консультации по применению компонента;
- Поставка образцов и прототипов;
- Техническая поддержка проекта;
- Защита от снятия компонента с производства.



Как с нами связаться

Телефон: 8 (812) 309 58 32 (многоканальный)

Факс: 8 (812) 320-02-42

Электронная почта: org@eplast1.ru

Адрес: 198099, г. Санкт-Петербург, ул. Калинина, дом 2, корпус 4, литера А.