

LUXEON Z

LUXEON Z ES

Breakthrough luminance, design flexibility
and optical control for Illumination solutions

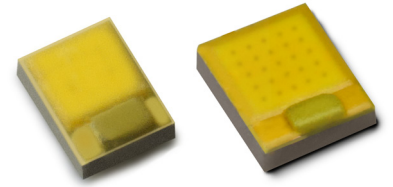

Introduction

Philips Lumileds technology enables the new LUXEON® Z and LUXEON Z ES LEDs.

The LUXEON Z is a family of micro sized Illumination grade emitters that is the first ever I-step MacAdam Ellipse warm white LED that enables never before seen color consistency, luminance, flux density and design flexibility for next generation lighting solutions. LUXEON Z family is undomed, a feature that provides un-matched optical flexibility for precise beam angle control. Tested and binned at application conditions 85°C, the LUXEON Z and Z ES emitters are an ideal choice for indoor and outdoor light sources requiring superior beam angles, higher efficiency and lower costs.

Features

- Micro sized: LUXEON Z, 1.3x1.7 mm and LUXEON Z ES, 1.6x2.0 mm
- Undomed device architecture
- Hot tested at 85°C
- Up to 1 A max drive current
- *Freedom from Binning*
- 1, 3, 5 step MCE options
- Lowest thermal resistance 3°C/W

Benefits

- Highest luminance to deliver punch
- Ultimate design flexibility from micro form factor
- Precise optical control from an undomed architecture
- Enables small customizable and scalable light engines
- Leading system level lm/\$ proposition

Key Applications

- Indoor area
- Lamps
 - MR16, PAR, GU10 and Candles
- Outdoor area
 - High-flux street light modules
- Specialty lighting
- Architectural

Table of Contents

General Information	2
Product Nomenclature	2
Average Lumen Maintenance Characteristics	2
Environmental Compliance	2
Product Selection	3
Optical Characteristics	4
Electrical Characteristics	4
Absolute Maximum Ratings	5
JEDEC Moisture Sensitivity	5
Mechanical Dimensions of LUXEON Z ES	6
Mechanical Dimensions of LUXEON Z	7
Solder Pad Design	8
Relative Spectral Distribution	9
Light Output Characteristics	10
Typical Spatial Radiation Pattern	14
Emitter Pocket Tape Packaging for LUXEON Z ES	16
Emitter Reel Packaging for LUXEON Z ES	16
Emitter Pocket Tape Packaging for LUXEON Z	17
Emitter Reel Packaging for LUXEON Z	18
Product Binning and Labeling	19
Luminous Flux and Forward Voltage Bins	20
LUXEON Z and LUXEON Z ES: 1-step, 3-step (above and below blackbody) and 5-step Mac Adam Ellipse Color Definition	21

General Information

Product Nomenclature

LUXEON Z and Z ES emitters are specified and binned under “hot” conditions comparable to those found in “real-world” lighting products. The test conditions for LUXEON Z ES and LUXEON Z are 700 mA DC and 500 mA DC respectively with junction temperature at 85°C

The part number designation is explained as follows:

L X Z n - a b c d - y

Where:

- n — 1 for LUXEON Z and 2 for LUXEON Z ES
- a, b — designates nominal ANSI CCT (27 for 2700K, 30 for 3000K, RB for Royal Blue)
- c, d — designates minimum CRI performance (7 for 70 CRI, 8 for 80 CRI, 9 for 90 CRI)
- y — 1 designates 1 SDCM, 3 designates 3 SDCM and 5 designates 5 SDCM (only for 80 and 90 CRI versions. Lower than equal to 70 CRI parts will not have a SDCM designate and all parts will be within 5 step MCE).

Therefore, 3 SDCM 2700K/80 CRI LUXEON Z ES will have the following part number:

L X Z 2 – 2 7 8 0 - 3

Therefore, 5 SDCM 3000K/80 CRI LUXEON Z will have the following part number:

L X Z 1 – 3 0 8 0 - 5

Average Lumen Maintenance Characteristics

LUXEON Z products are tested in compliance with LM-80. Please visit www.philipslumileds.com/support/documentation/lumen-maintenance or contact your local Philips Lumileds Technical Solutions Manager for TM-21 extrapolations or other support.

Environmental Compliance

Philips Lumileds is committed to providing environmentally friendly products to the solid-state lighting market.

LUXEON Z and LUXEON Z ES products are compliant to the European Union directives on the restriction of hazardous substances in electronic equipment, namely the RoHS and REACH directives. Philips Lumileds will not intentionally add the following restricted material to the LUXEON Z and LUXEON Z ES: lead, mercury, cadmium, hexavalent chromium, polybrominated biphenyls (PBB) or polybrominated diphenyl ethers (PBDE).

Product Selection

Product Selection Guide for LUXEON Z ES Emitters Junction Temperature = 85°C

Table 1.

LUXEON Z ES		@ 700 mA				@ 1A			@ 350 mA		
Part Number	Normal CCT / CRI	Min Flux (lm)	Typ flux (Lm)	Typ. Vf	Typ. Lm/W	Typ flux (Lm)	Typ. Vf	Typ. Lm/W	Typ flux (Lm)	Typ. Vf	Typ. Lm/W
LXZ2-2780-Y	2700 / 80	160	175	2.85	88	224	2.90	77	99	2.77	102
LXZ2-2790-Y	2700 / 90	110	135	2.85	68	178	2.90	61	78	2.77	81
LXZ2-3080-Y	3000 / 80	160	180	2.85	91	238	2.90	82	104	2.77	108
LXZ2-3090-Y	3000 / 90	120	145	2.85	73	178	2.90	61	78	2.77	81
LXZ2-3580-Y	3500 / 80	170	190	2.85	95	244	2.90	84	107	2.77	111
LXZ2-4080-Y	4000 / 80	180	195	2.85	98	257	2.90	89	113	2.77	117
LXZ2-4070	4000 / 70	190	210	2.85	106	277	2.90	96	122	2.77	126
LXZ2-5070	5000 / 70	200	215	2.85	108	284	2.90	98	125	2.77	129
LXZ2-5770	5700 / 70	200	215	2.85	108	284	2.90	98	125	2.77	129

Notes for Table 1:

1. All LUXEON Z ES emitters are tested and binned at 700 mA/85C.
2. Philips Lumileds maintains a tolerance of $\pm 6.5\%$ on luminous flux and ± 2 on CRI measurements.

Product Selection for LUXEON Z Emitters Junction Temperature = 85°C

Table 2.

LUXEON Z		@ 500 mA				@ 700 mA			@ 350 mA		
Part Number	Normal CCT / CRI	Min Flux (lm)	Typ flux (Lm)	Typ. Vf	Typ. Lm/W	Typ flux (Lm)	Typ. Vf	Typ. Lm/W	Typ flux (Lm)	Typ. Vf	Typ. Lm/W
LXZ1-2780-Y	2700 / 80	90	105	2.85	74	134	2.89	66	81	2.81	82
LXZ1-3080-Y	3000 / 80	100	110	2.85	78	141	2.89	70	85	2.81	86
LXZ1-4080-Y	4000 / 80	100	126	2.85	89	161	2.89	80	97	2.81	99
LXZ1-4070	4000 / 70	100	132	2.85	93	169	2.89	84	102	2.81	103
LXZ1-5070	5000 / 70	110	142	2.85	100	182	2.89	90	109	2.81	111
LXZ1-5770	5700 / 70	110	148	2.85	104	189	2.89	94	114	2.81	116
LXZ1-6565	6500 / 65	110	135	2.85	95	173	2.89	85	104	2.81	106

Notes for Table 2:

1. All LUXEON Z emitters above are tested and binned at 500 mA/85C.
2. Philips Lumileds maintains a tolerance of $\pm 6.5\%$ on luminous flux and ± 2 on CRI measurements.

Optical Characteristics

LUXEON Z ES at Test Current 700 mA, Junction Temperature 85°C & LUXEON Z at Test Current 500 mA, Junction Temperature 85°C

Table 3.

Nominal ANSI CCT	Color Temperature CCT Typical	Typical Total Included Angle ² (degrees) $\theta_{0.90V}$	Typical Viewing Angle ³ (degrees) $2\theta_{1/2}$
2700K	2725K	160	120
3000K	3045K	160	120
3500K	3465K	160	120
4000K	3985K	160	120
5000K	5028K	160	120
5700K	5665K	160	120

Notes for Table 3:

1. Total angle at which 90% of total luminous flux is captured.
2. Viewing angle is the off axis angle from lamp centerline where the luminous intensity is 1/2 of the peak value.

Electrical Characteristics

LUXEON Z ES at Test Current 700 mA, Junction Temperature 85°C & LUXEON Z at Test Current 500 mA, Junction Temperature 85°C

Table 4.

Nominal ANSI CCT	Forward Voltage V _f ¹ (V)		Typical Temperature Coefficient of Forward Voltage ² (mV/°C) $\Delta V_f / \Delta T_j$	Typical Thermal Resistance Junction to Thermal Pad (°C/W) $R_{\theta_{j-c}}$
	Min.	Max.		
2700K	2.5	3.25	-1.6	3
3000K	2.5	3.25	-1.6	3
3500K	2.5	3.25	-1.6	3
4000K	2.5	3.25	-1.6	3
5000K	2.5	3.25	-1.6	3
5700K	2.5	3.25	-1.6	3
6500K	2.5	3.25	-1.6	3

Notes for Table 4:

1. Philips Lumileds maintains a tolerance of $\pm 0.06V$ on forward voltage measurements.
2. Measured between $T_j = 25^\circ C$ and $T_j = 110^\circ C$ at $I_f = 700$ mA.

Absolute Maximum Ratings

Table 5.

Parameter	LUXEON Z ES	LUXEON Z
DC Forward Current (mA) ^{1,2}	1050	700
Peak Pulsed Forward Current (mA) ^{1,3}	1200	1000
ESD Sensitivity	< 8000V Human Body Model (HBM) Class 3A JESD22-A114-E	< 8000V Human Body Model (HBM) Class 3A JESD22-A114-E
LED Junction Temperature ¹	135°C	135°C
Operating Case Temperature at 700 mA	-40°C - 135°C	-40°C - 135°C
Storage Temperature	-40°C - 135°C	-40°C - 135°C
Soldering Temperature	JEDEC 020c 260°C	JEDEC 020c 260°C
Allowable Reflow Cycles	3	3
Reverse Voltage (Vr) ^{5,6}	LUXEON Z LEDs are not designed to be driven in reverse bias	

Notes for Table 5:

- Proper current derating must be observed to maintain junction temperature below the maximum. For additional information on thermal measurement guidelines please refer to Application Brief AB106.
- Residual periodic variations due to power conversion from alternating current (AC) to direct current (DC), also called "ripple", with frequencies ≥ 100 Hz and amplitude ≤ 200 mA are acceptable, assuming the average current throughout each cycle does not exceed 1000 mA.
- Pulsed operation with a peak drive current of 1200 mA is acceptable if the pulse on-time is ≤ 5 ms per cycle and the duty cycle is $\leq 50\%$.
- Transient reverse voltages and surge currents due to electrical switching or supply interruptions are acceptable if these events do not last for more than 10ms, the amplitude of the reverse voltage does not exceed 5V and the reverse current is less than 200 μ A.
- Max 5V reverse for up to 10s is an acceptable beginning of life, one time test condition.

JEDEC Moisture Sensitivity

Table 6.

Level	Floor Life		Soak Requirements Standard	
	Time	Conditions	Time	Conditions
I	unlimited	$\leq 30^\circ\text{C}$ / 85% RH	168h + 5 / - 0	85°C / 85% RH

Mechanical Dimensions of LUXEON Z ES

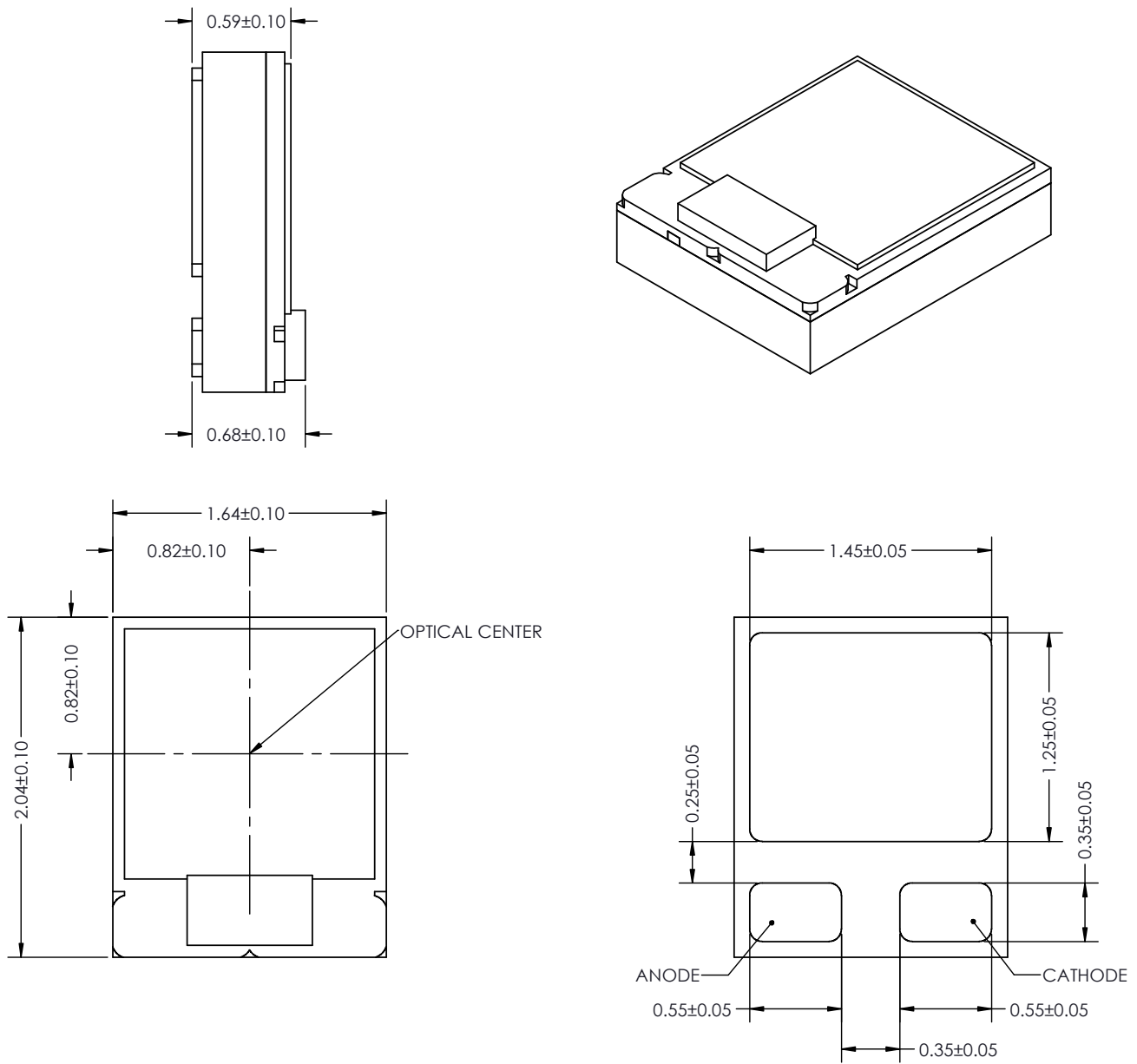

Figure 1. Package outline drawing for LUXEON Z ES.

Notes for Figure 1:

1. Do not handle the device by the lens. Excessive force on the lens may damage the lens itself or the interior of the device.
2. Drawings not to scale.
3. All dimensions are in millimeters.
4. The thermal pad is electrically isolated from the anode and cathode contact pads.

Mechanical Dimensions of LUXEON Z

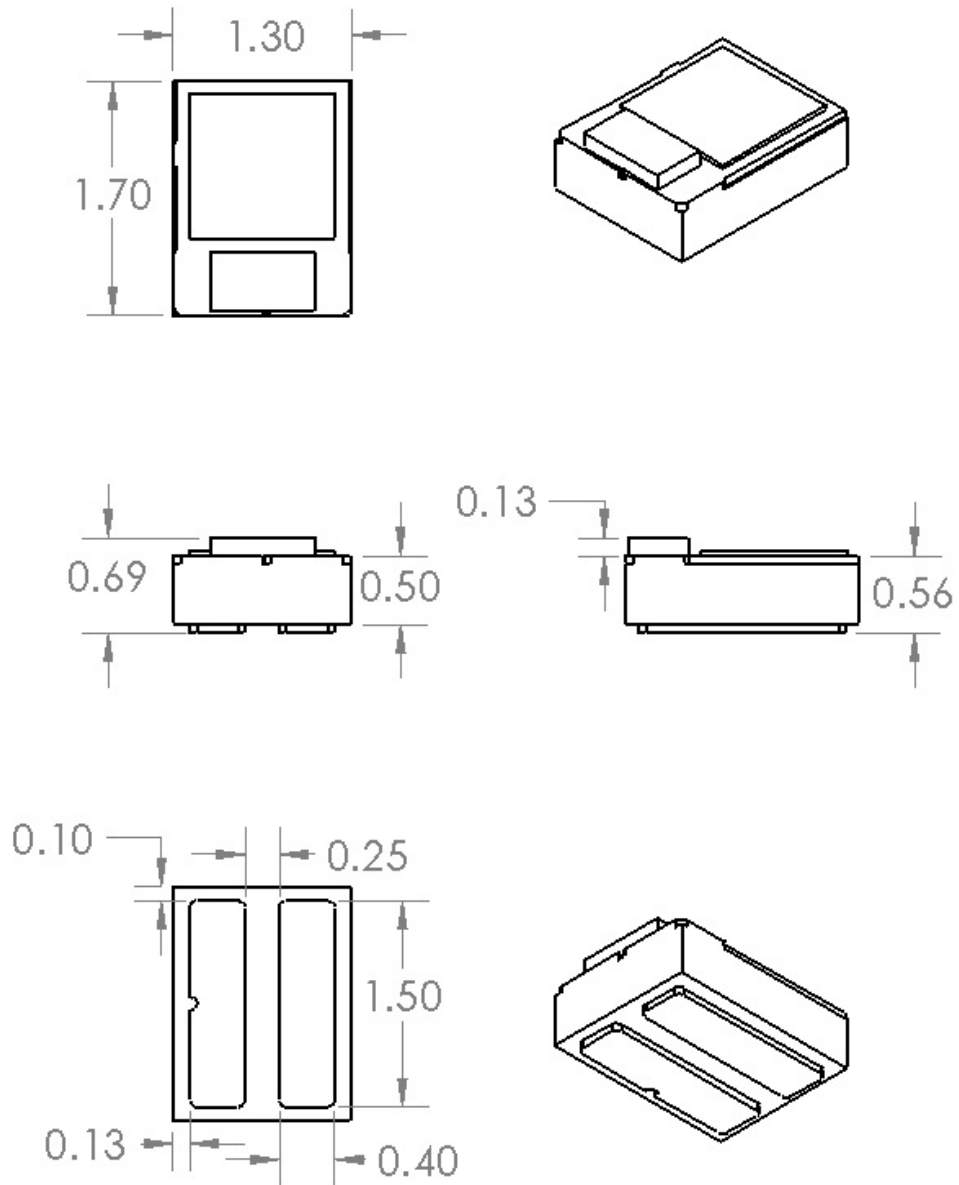

Figure 2. Package outline drawing for LUXEON Z.

Notes for Figure 2:

1. Do not handle the device by the lens. Excessive force on the lens may damage the lens itself or the interior of the device.
2. Drawings not to scale.
3. All dimensions are in millimeters.
4. The thermal pad is electrically isolated from the anode and cathode contact pads.

Solder Pad Design

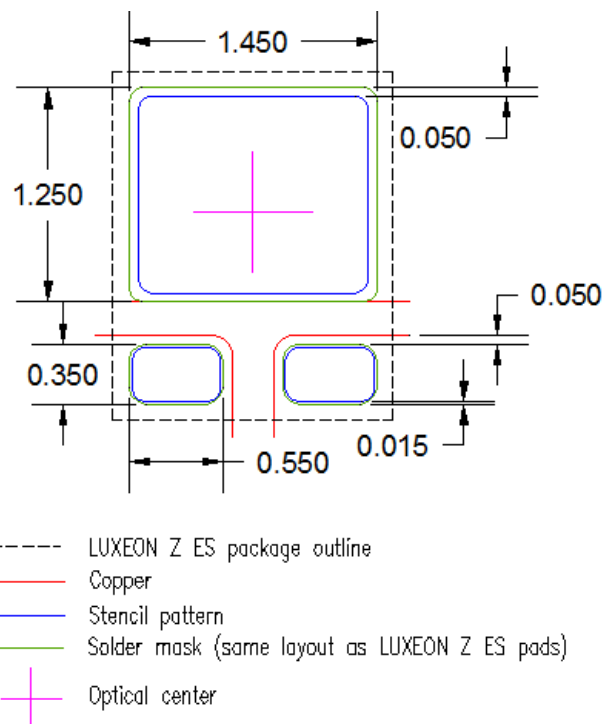

Figure 3. Layout design B. Recommended PCB footprint for LUXEON Z ES for high component count density based on solder mask defined pads. Dimensions in mm..

Notes for Figure 3:

1. The drawing above shows the recommended solder pad layout on Printed Circuit Board (PCB).
2. Application Brief AB202 provides extensive details for this layout. In addition, the .dwg files are available at www.philipslumileds.com and www.philipslumileds.cn.com.

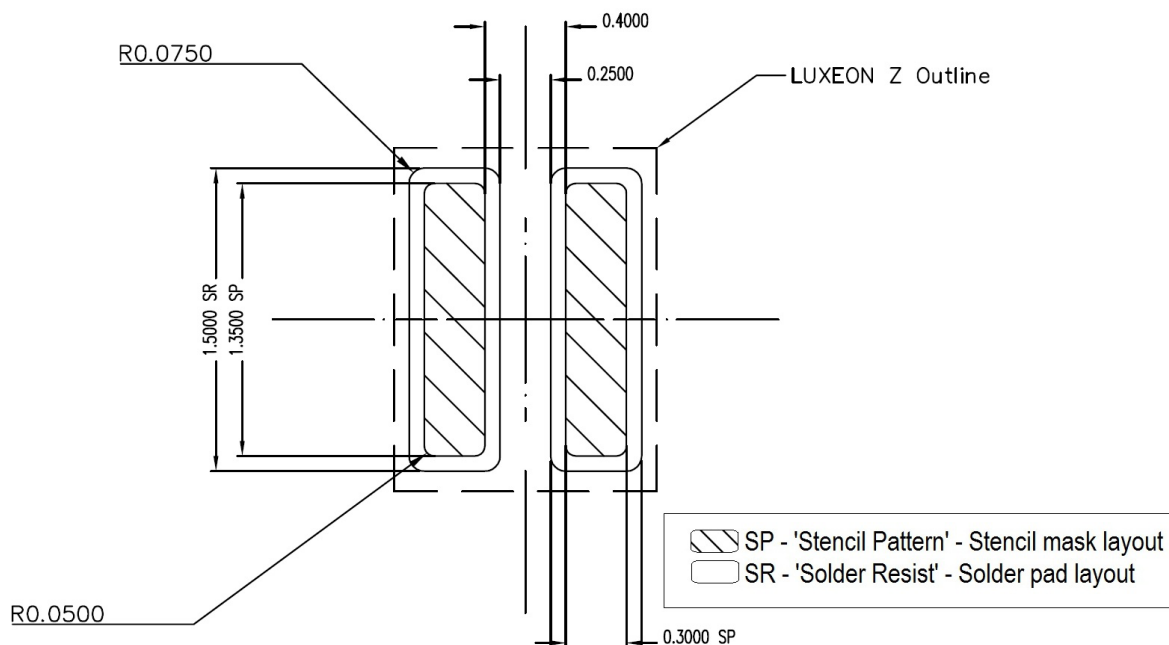

Figure 4. Solder pad layout for LUXEON Z.

Relative Spectral Distribution

Relative Spectral Distribution vs. Wavelength Characteristics

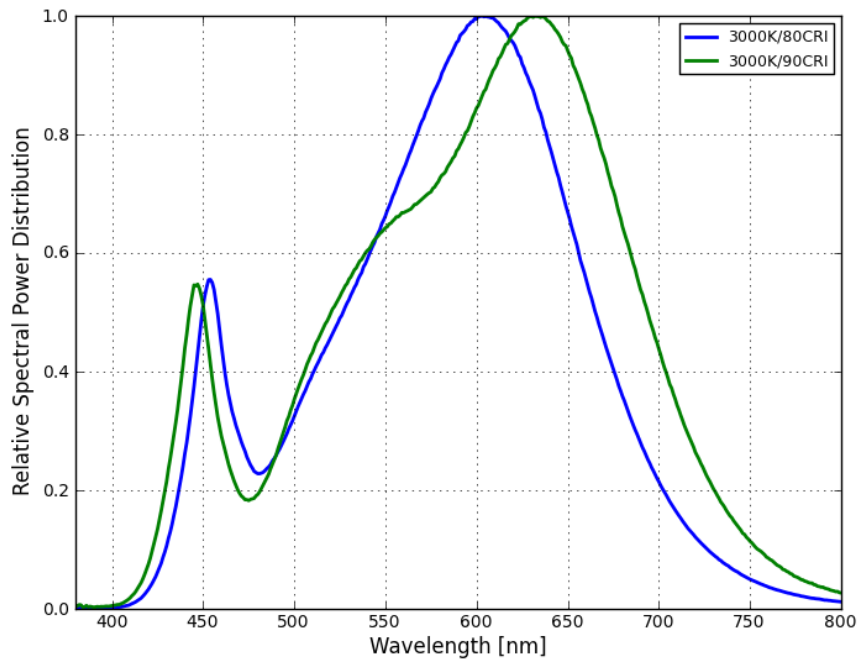

Figure 5.

Light Output Characteristics

Relative Light Output vs. Thermal Pad Temperature for LUXEON Z ES,
Test Current at 700 mA

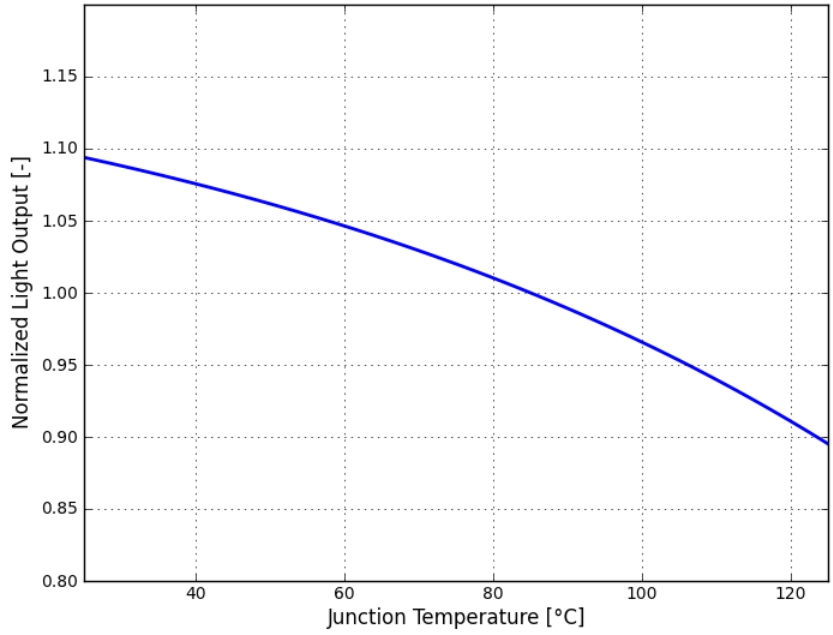

Figure 6.

Relative Light Output vs. Forward Current for LUXEON Z ES,
Thermal Pad temperature = 85°C

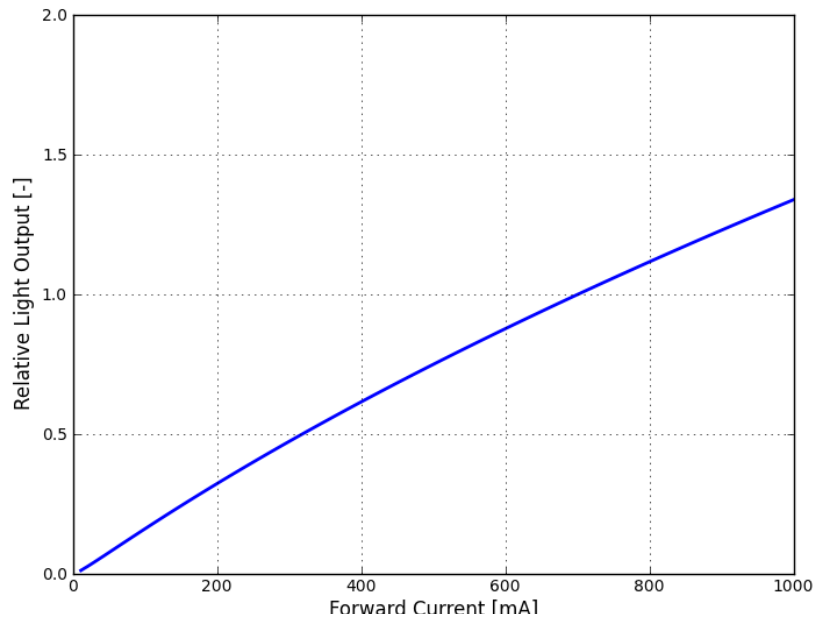

Figure 7.

Forward Current Characteristics for LUXEON Z ES,
Thermal Pad Temperature = 85°C

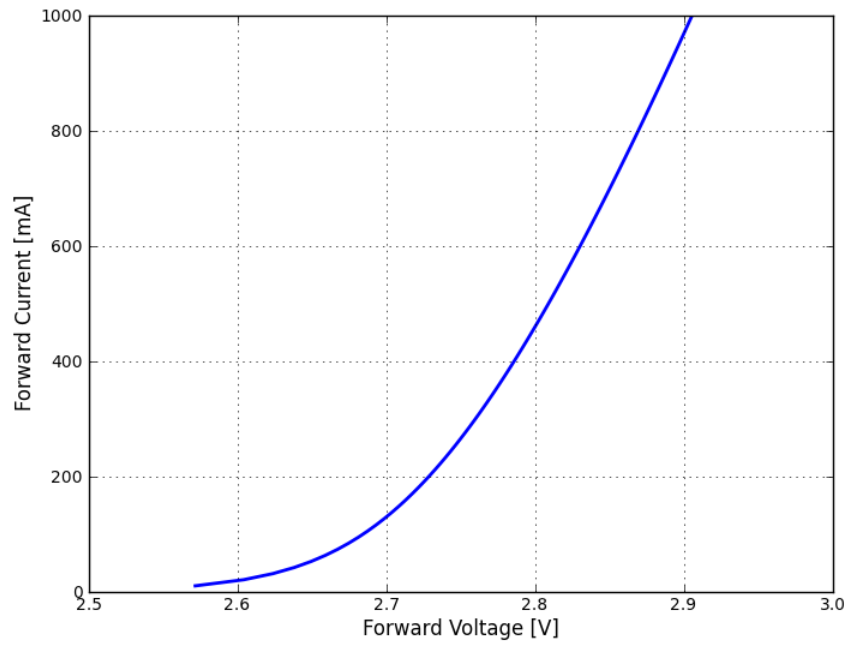

Figure 8.

Relative Light Output vs. Thermal Pad Temperature for LUXEON Z White, Test Current at 500 mA

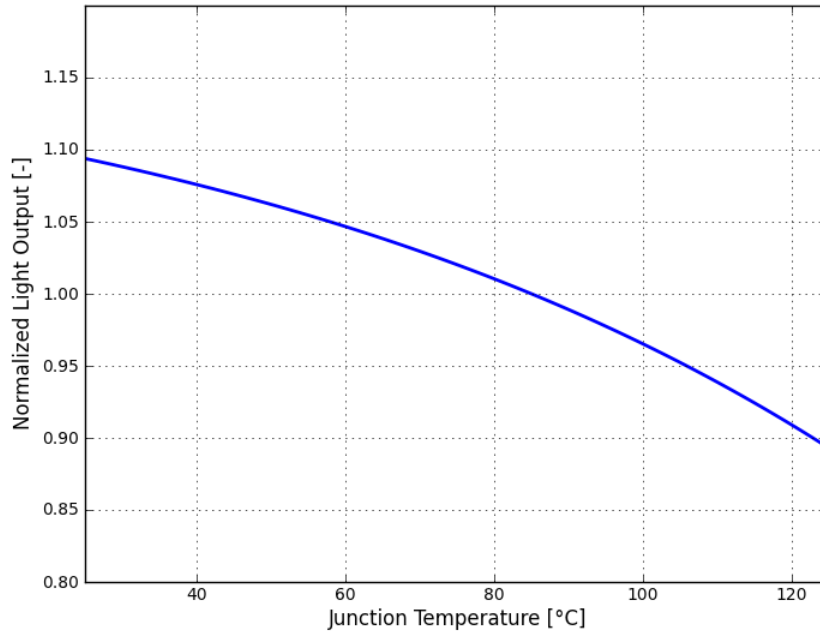

Figure 9.

Relative Light Output vs. Forward Current for LUXEON Z White, Thermal Pad Temperature = 85°C

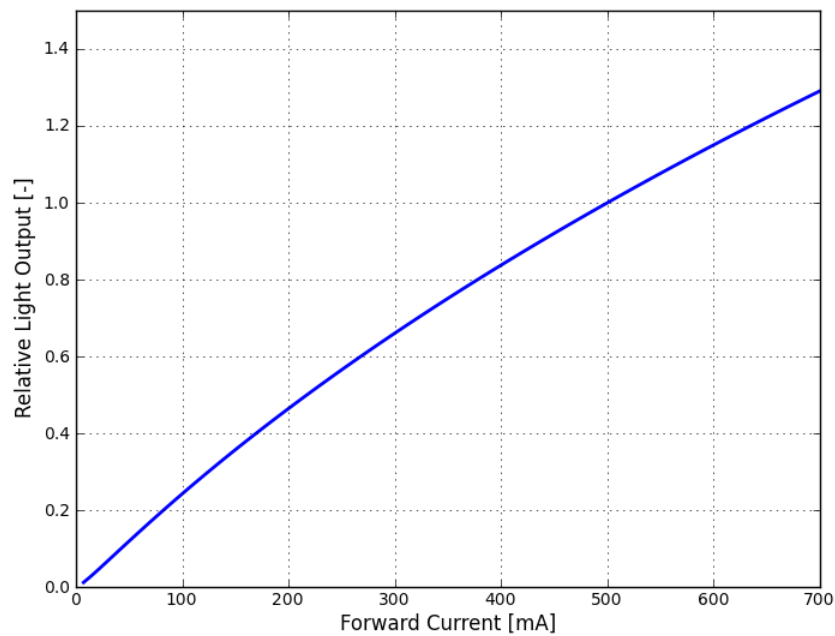

Figure 10.

Forward Current Characteristics for LUXEON Z White,
Thermal Pad Temperature = 85°C

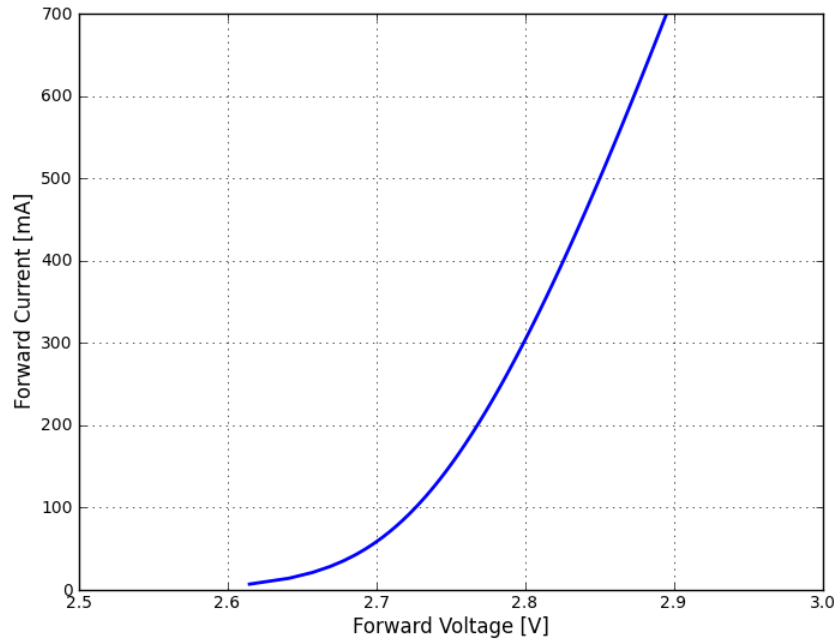

Figure 11.

Typical Spatial Radiation Pattern

LUXEON Z ES

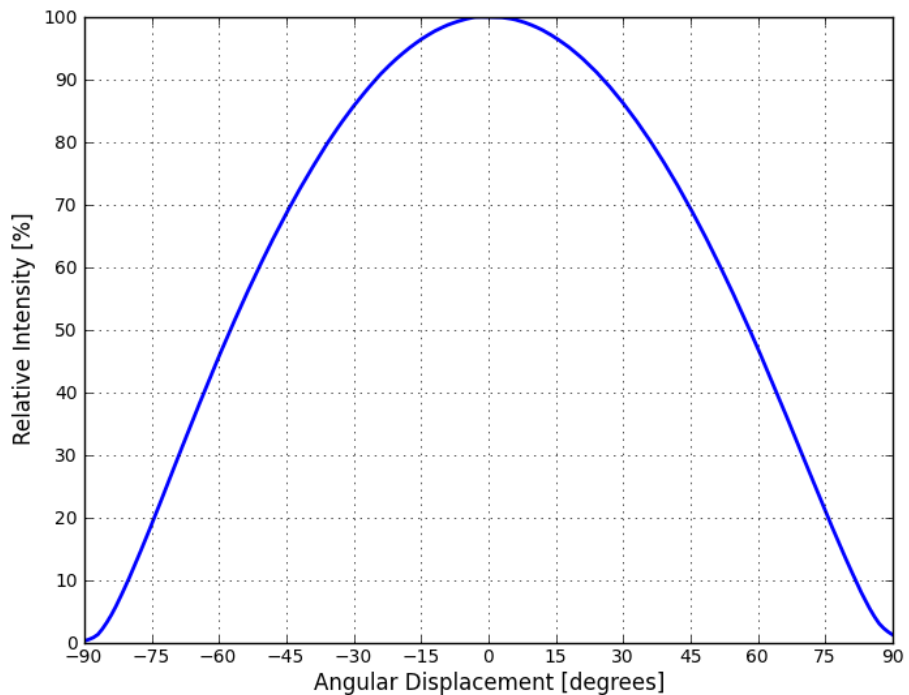

Figure 12.

LUXEON Z ES Typical Polar Radiation Pattern

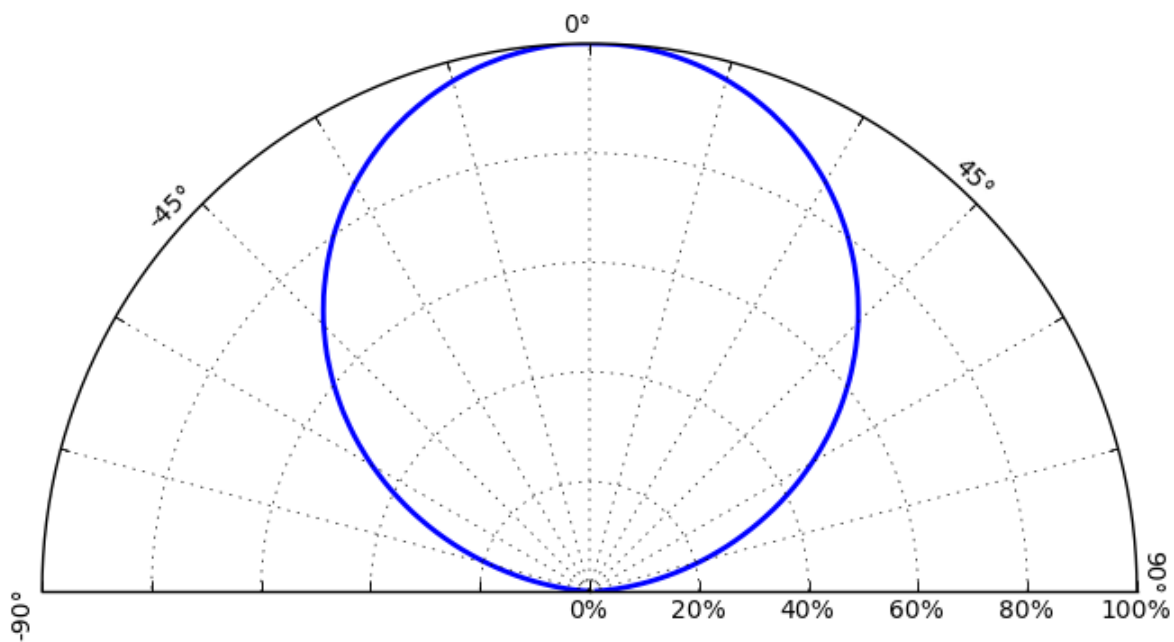

Figure 13.

Typical Spatial Radiation Pattern

LUXEON Z

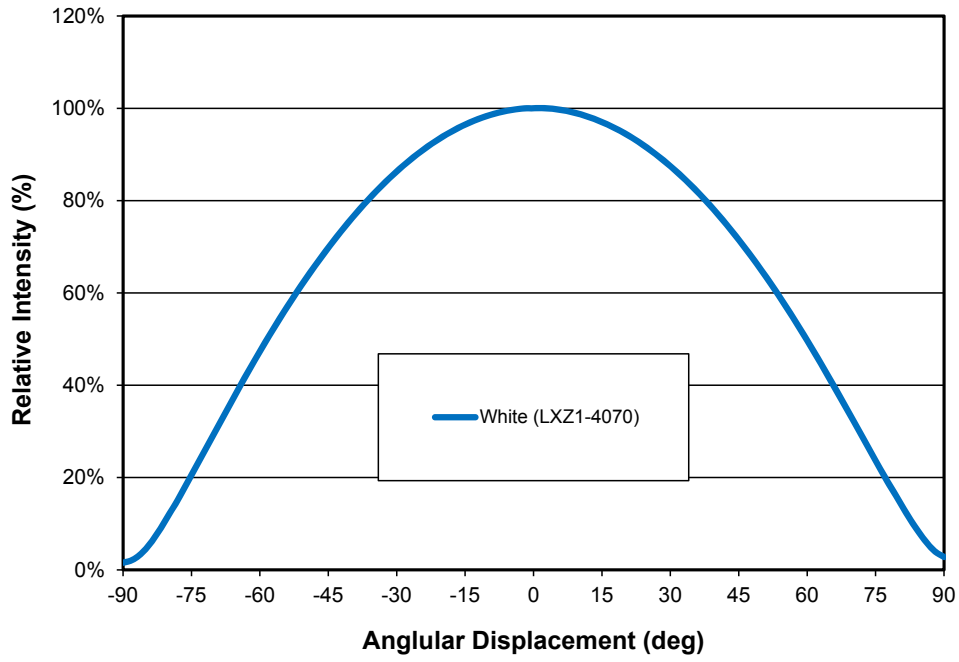

Figure 14.

LUXEON Z Typical Polar Radiation Pattern

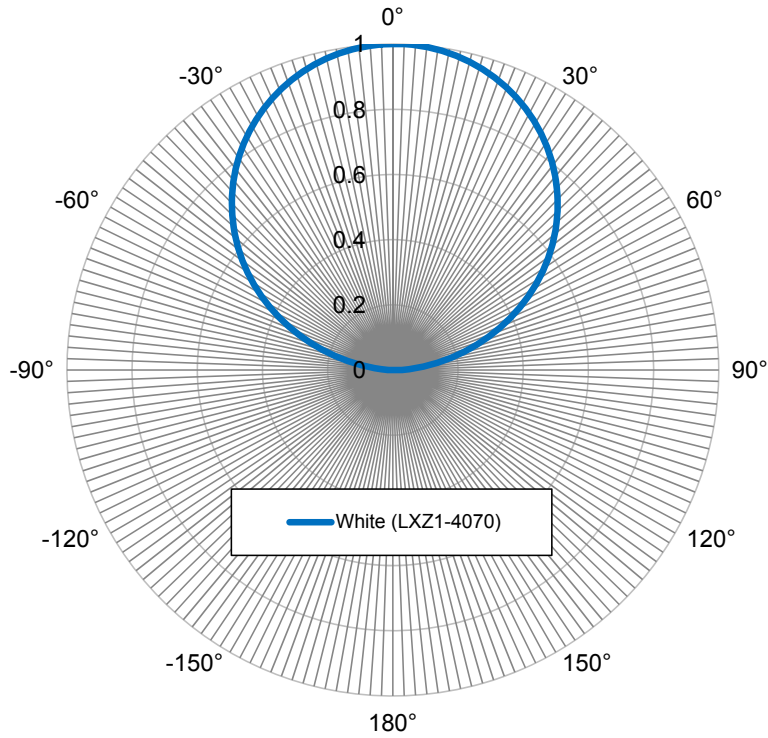

Figure 15.

Emitter Pocket Tape Packaging for LUXEON Z ES

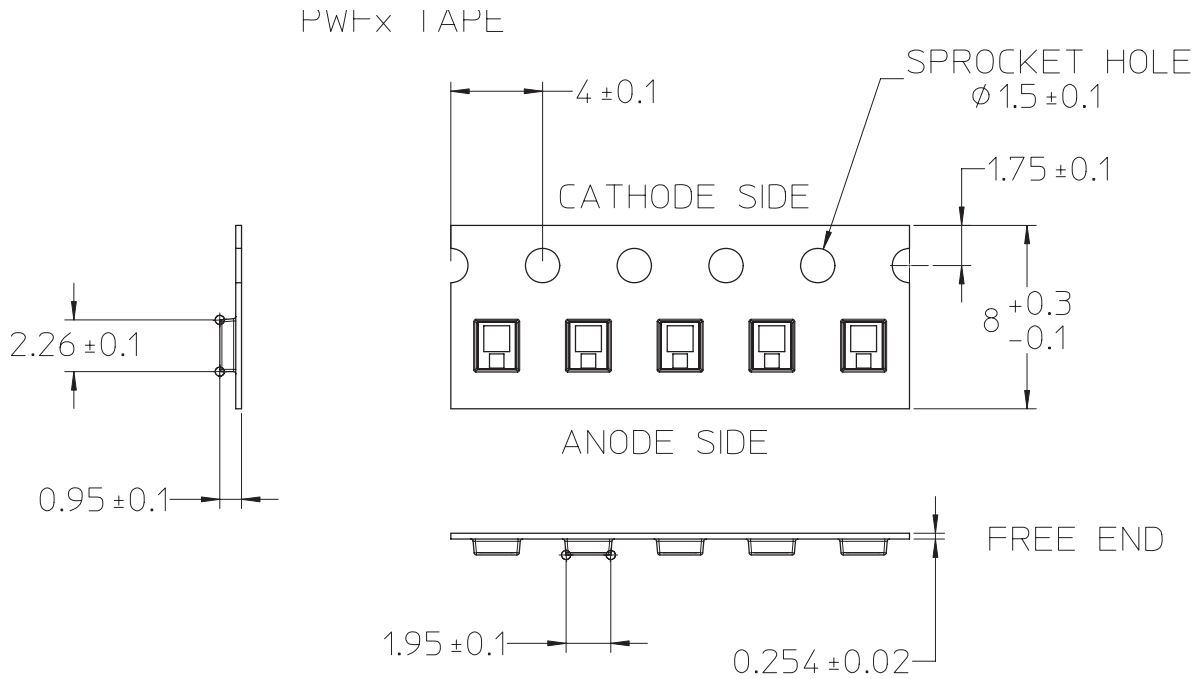

Figure 16. Emitter pocket tape packaging for LUXEON Z ES.

Notes for Figure 16:

1. All dimensions are in millimeters

Emitter Reel Packaging for LUXEON Z ES

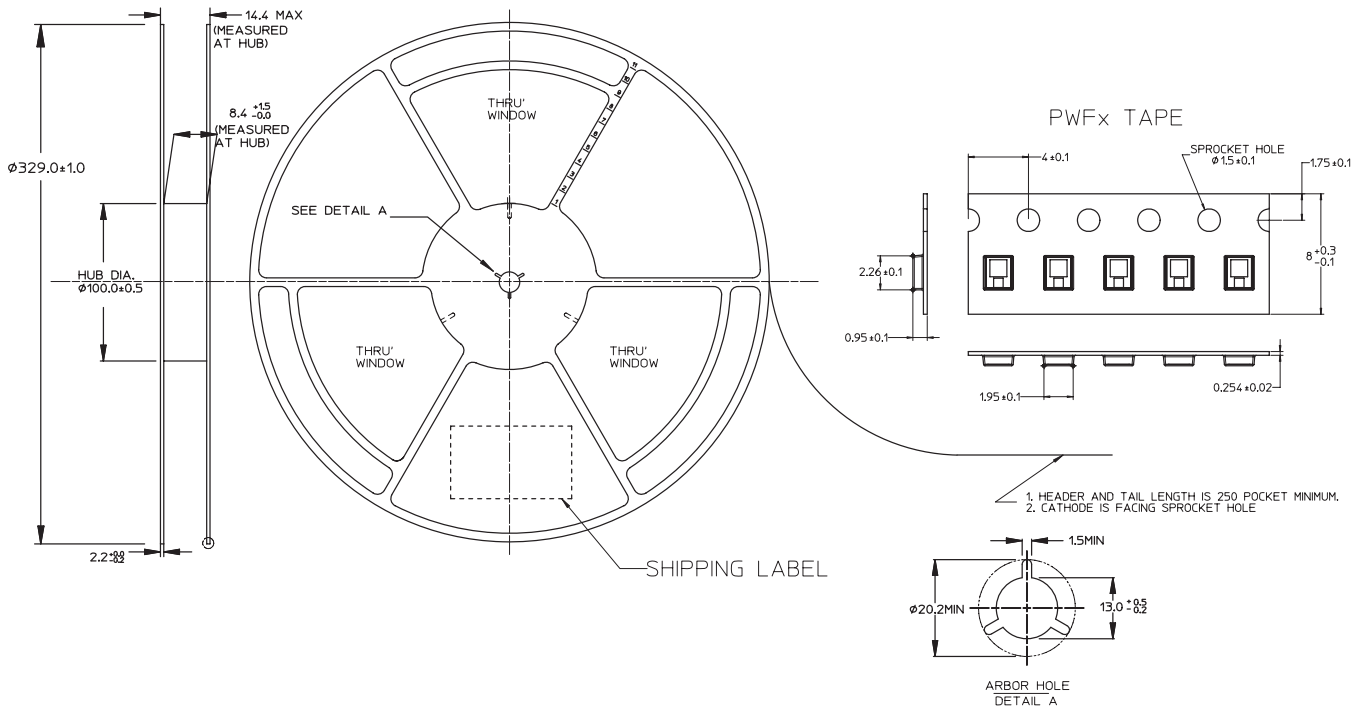

Figure 17. Emitter reel packaging for LUXEON Z ES.

Emitter Pocket Tape Packaging for LUXEON Z

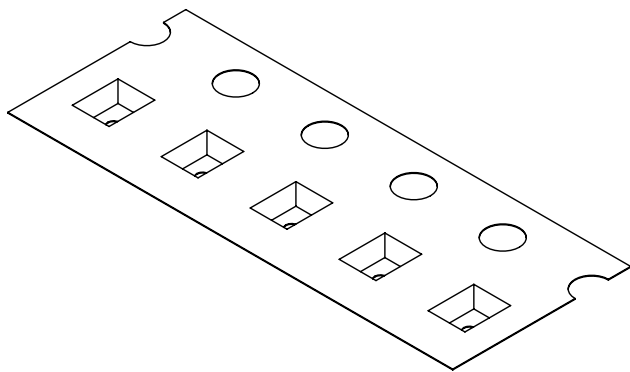
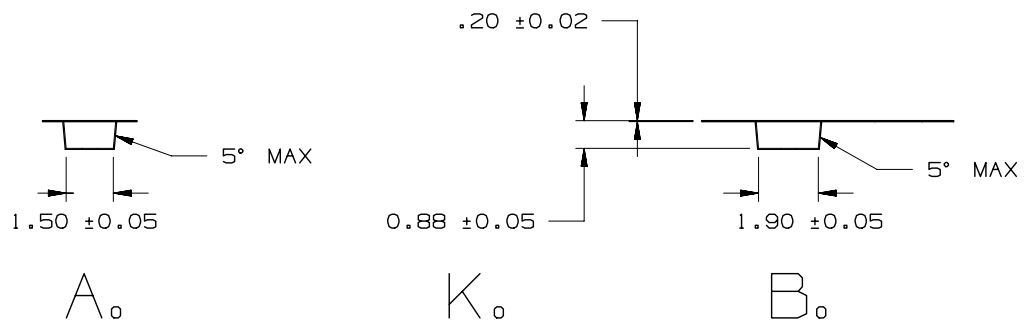
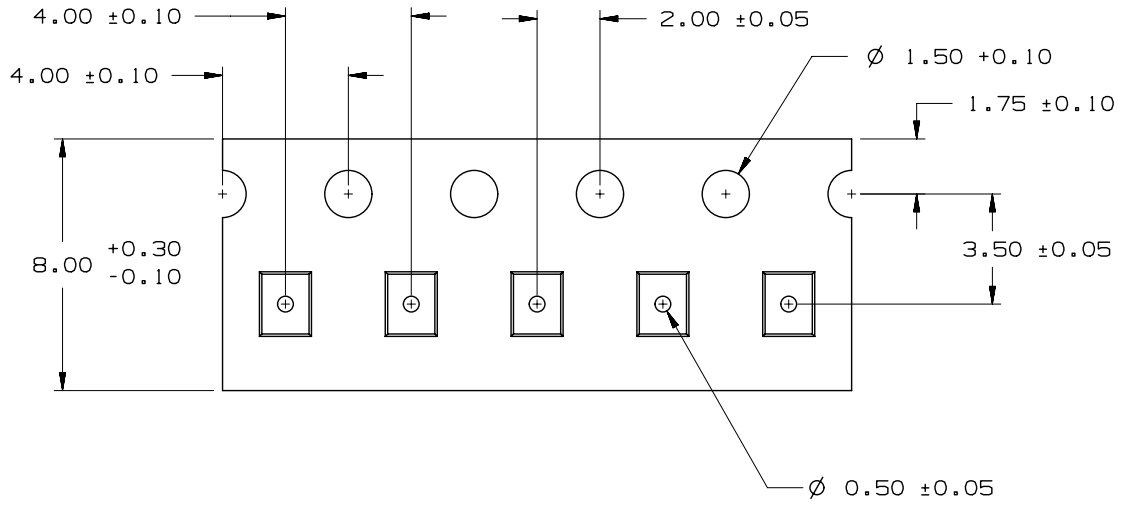

Figure 18. Emitter pocket tape packaging for LUXEON Z.

Notes for Figure 18:

- I. All dimensions are in millimeters

Emitter Reel Packaging for LUXEON Z

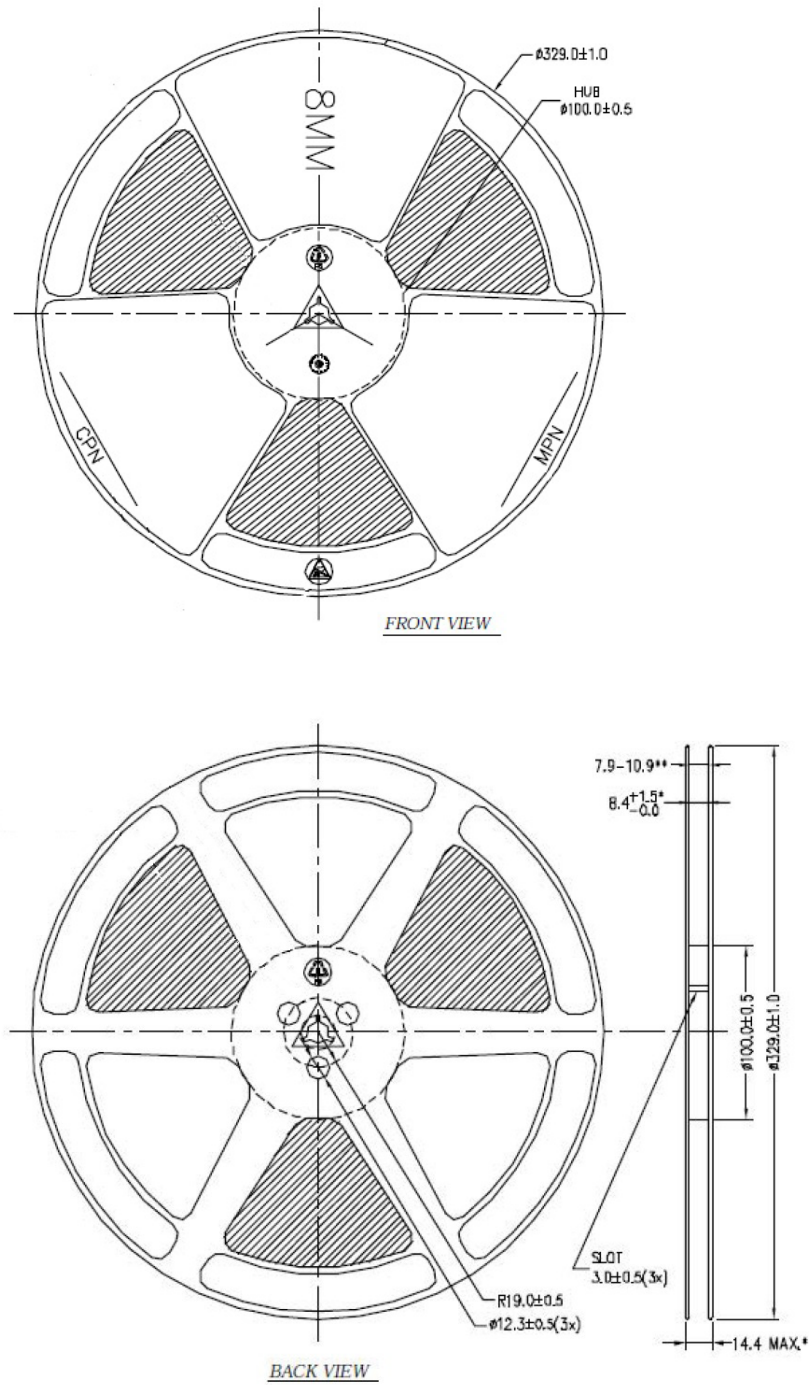

Figure 19. Emitter reel packaging for LUXEON Z.

Product Binning and Labeling

Purpose of Product Binning

In the manufacturing of semiconductor products, there are variations in performance around the average values given in the technical data sheets. For this reason, Philips Lumileds bins the LED components for luminous flux and forward voltage (V_f). Color is offered in a single 1 step, 3-step or 5-step MacAdam ellipse color space centered on the ANSI CCT color bins. For additional information please review the MacAdam ellipse technical definition section.

Decoding Product Bin Labeling

LUXEON Z ES and LUXEON Z emitters are labeled using a four digit alphanumeric code (CAT code) depicting the bin values for emitters packaged on a single reel. All emitters packaged within a reel are of the same 3-variable bin combination. Reels of LUXEON Z emitters are labeled with a four digit alphanumeric CAT code following the format below.

ABCD

A = Flux/Radiometric power bin (L, M, etc.)

B and C = Color Bin (5A, 5B, 5C, 5D, 3U, 3L, 0I)

D = V_f bin (P,R)

Luminous Flux and Forward Voltage Bins

Table 7 lists the standard photometric luminous flux bins for LUXEON Z ES and LUXEON Z emitters (tested and binned at 700 mA and 500 mA $T_j = 85^\circ\text{C}$). Although several bins are outlined, product availability in a particular bin varies by production run and by product performance. Not all bins are available in all colors.

Table 7. Flux Bins

Bin Code	Minimum Photometric Flux (lm)	Maximum Photometric Flux (lm)
A	100	110
B	110	120
C	120	130
D	130	140
E	140	150
F	150	160
G	160	170
H	170	180
J	180	190
K	190	200
L	200	210
M	210	220
N	220	230
P	230	240

Table 8 lists minimum and maximum V_f bin values per emitter. Although several bins are outlined, product availability in a particular bin varies by production run and by product performance.

Table 8. V_f Bins

Bin Code	Minimum Forward Voltage (V)	Maximum Forward Voltage (V)
P	2.50	2.75
R	2.75	3.00
S	3.00	3.25

LUXEON Z and LUXEON Z ES: 1-step, 3-step (above and below blackbody) and 5-step MacAdam Ellipse Color Definition

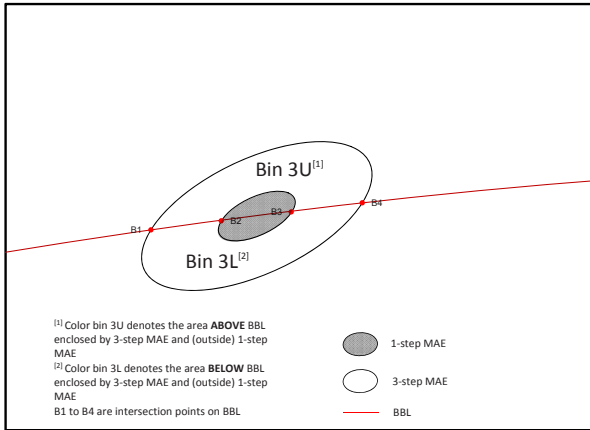

Color Space Definition for Above and Below Blackbody

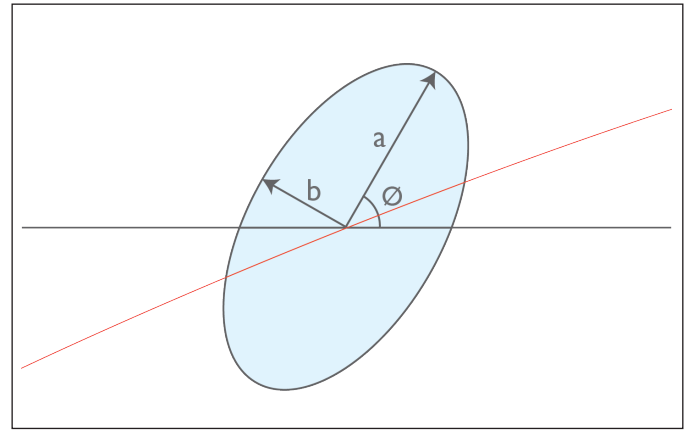

Parameter Definition of MacAdam Ellipse

Table 9. LUXEON Z and LUXEON Z ES 1-step MacAdam Ellipse Parameters

Nominal ANSI CCT	Color Space	Center Point (cx, cy)	Major Axis, a	Minor Axis, b	Ellipse Rotation Angle
2700K	Single 1-step MacAdam ellipse	(0.4578, 0.4101)	0.00270	0.00140	53.70
3000K	Single 1-step MacAdam ellipse	(0.4338, 0.4030)	0.00278	0.00136	53.22
3500K	Single 1-step MacAdam ellipse	(0.4073, 0.3917)	0.00309	0.00138	54.00

Table 10. LUXEON Z and LUXEON Z ES 3-step MacAdam Ellipse Parameters

Nominal ANSI CCT	Color Space	Center Point (cx, cy)	Major Axis, a	Minor Axis, b	Ellipse Rotation Angle
2700K	Single 3-step MacAdam ellipse	(0.4578, 0.4101)	0.00810	0.00420	53.7
3000K	Single 3-step MacAdam ellipse	(0.4338, 0.4030)	0.00834	0.00408	53.2
3500K	Single 3-step MacAdam ellipse	(0.4073, 0.3917)	0.00927	0.00414	54.0
4000K	Single 3-step MacAdam ellipse	(0.3818, 0.3797)	0.00939	0.00402	53.7
5000K	Single 3-step MacAdam ellipse	(0.3447, 0.3553)	0.00822	0.00354	59.6

Table 11. LUXEON Z and LUXEON Z ES 5-step MacAdam Ellipse Parameters

Nominal ANSI CCT	Color Space	Center Point (cx, cy)	Major Axis, a	Minor Axis, b	Ellipse Rotation Angle
2700K	Single 5-step MacAdam ellipse	(0.4578, 0.4101)	0.01350	0.00700	53.7
3000K	Single 5-step MacAdam ellipse	(0.4338, 0.4030)	0.01390	0.00680	53.2
3500K	Single 5-step MacAdam ellipse	(0.4073, 0.3917)	0.01545	0.00690	54.0
4000K	Single 5-step MacAdam ellipse	(0.3818, 0.3797)	0.01565	0.00670	53.7
5000K	Single 5-step MacAdam ellipse	(0.3447, 0.3553)	0.01370	0.00590	59.6
5700K	Single 5-step MacAdam ellipse	(0.3287, 0.3417)	0.01243	0.00533	59.09

Note for Tables 9, 10 & 11:

- Philips Lumileds maintains a tester tolerance of ± 0.005 on x, y color coordinates.



Company Information

Philips Lumileds is a leading provider of LEDs for everyday lighting applications. The company's records for light output, efficacy and thermal management are direct results of the ongoing commitment to advancing solid-state lighting technology and enabling lighting solutions that are more environmentally friendly, help reduce CO₂ emissions and reduce the need for power plant expansion. Philips Lumileds LUXEON® LEDs are enabling never before possible applications in outdoor lighting, shop lighting, home lighting, digital imaging, display and automotive lighting.

Philips Lumileds is a fully integrated supplier, producing core LED material in all three base colors, (Red, Green, Blue) and white. Philips Lumileds has R&D centers in San Jose, California and in the Netherlands, and production capabilities in San Jose, Singapore and Penang, Malaysia. Founded in 1999, Philips Lumileds is the high flux LED technology leader and is dedicated to bridging the gap between solid-state technology and the lighting world. More information about the company's LUXEON LED products and solid-state lighting technologies can be found at www.philipslumileds.com.

Philips Lumileds Lighting Company shall not be liable for any kind of loss of data or any other damages, direct, indirect or consequential, resulting from the use of the provided information and data. Although Philips Lumileds Lighting Company has attempted to provide the most accurate information and data, the materials and services information and data are provided "as is" and Philips Lumileds Lighting Company neither warranties, nor guarantees the contents and correctness of the provided information and data. Philips Lumileds Lighting Company reserves the right to make changes without notice. You as user agree to this disclaimer and user agreement with the download or use of the provided materials, information and data.



©2013 Philips Lumileds Lighting Company. All rights reserved.
LUXEON is a registered trademark of the Philips Lumileds Lighting Company in the United States and other countries.

www.philipslumileds.com
www.philipslumileds.cn.com

LUXEON Z and LUXEON Z ES Datasheet DS120 20130517



Компания «ЭлектроПласт» предлагает заключение долгосрочных отношений при поставках импортных электронных компонентов на взаимовыгодных условиях!

Наши преимущества:

- Оперативные поставки широкого спектра электронных компонентов отечественного и импортного производства напрямую от производителей и с крупнейших мировых складов;
- Поставка более 17-ти миллионов наименований электронных компонентов;
- Поставка сложных, дефицитных, либо снятых с производства позиций;
- Оперативные сроки поставки под заказ (от 5 рабочих дней);
- Экспресс доставка в любую точку России;
- Техническая поддержка проекта, помощь в подборе аналогов, поставка прототипов;
- Система менеджмента качества сертифицирована по Международному стандарту ISO 9001;
- Лицензия ФСБ на осуществление работ с использованием сведений, составляющих государственную тайну;
- Поставка специализированных компонентов (Xilinx, Altera, Analog Devices, Intersil, Interpoint, Microsemi, Aeroflex, Peregrine, Syfer, Eurofarad, Texas Instrument, Miteq, Cobham, E2V, MA-COM, Hittite, Mini-Circuits, General Dynamics и др.);

Помимо этого, одним из направлений компании «ЭлектроПласт» является направление «Источники питания». Мы предлагаем Вам помощь Конструкторского отдела:

- Подбор оптимального решения, техническое обоснование при выборе компонента;
- Подбор аналогов;
- Консультации по применению компонента;
- Поставка образцов и прототипов;
- Техническая поддержка проекта;
- Защита от снятия компонента с производства.



Как с нами связаться

Телефон: 8 (812) 309 58 32 (многоканальный)

Факс: 8 (812) 320-02-42

Электронная почта: org@eplast1.ru

Адрес: 198099, г. Санкт-Петербург, ул. Калинина, дом 2, корпус 4, литера А.