

TE CONNECTIVITY (TE) RESERVES THE RIGHT TO CHANGE THIS DRAWING AT ANYTIME. USERS SHOULD EVALUATE THE SUITABILITY OF THE PRODUCT FOR THEIR APPLICATION.

REVISION			
LTR	DESCRIPTION	DATE	APPROVED
K	REVISED PER ECO-15-003652	03/06/2015	I. MYONG

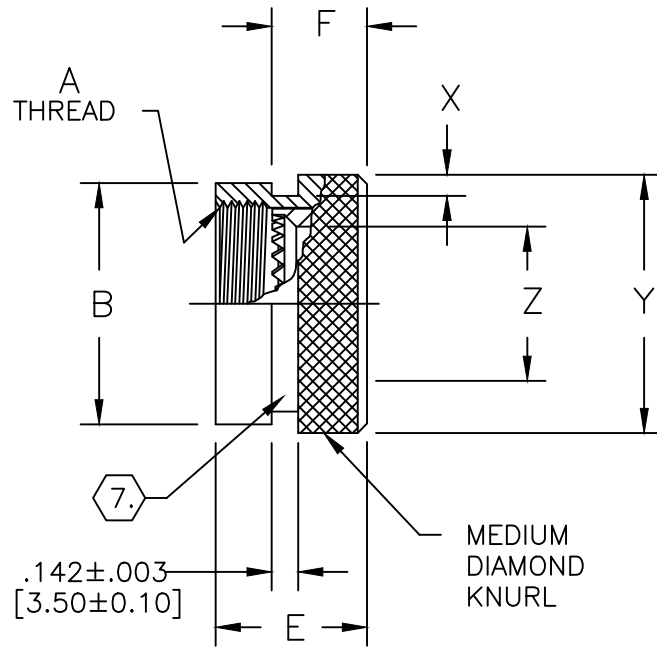

NOTES:

- THIS PRODUCT IS DESIGNED TO TERMINATE A HEAT SHRINKABLE LIPPED BOOT TO A CONNECTOR.
- FOR ADDITIONAL DIMENSIONS, ORDERING INFORMATION AND MODIFICATIONS, SEE CH00-0250-00
- ADAPTER TO BE PERMANENTLY MARKED WITH CODE IDENT. NO. AND PART NO. (E.G.: 06090-201M912-19A YYWW).
- ADAPTER MATES TO SAE-AS81703, SERIES III, AS34241, AS34461, AS34641, AS34671, CLASS E & L.
- ADAPTER MATES TO SAE-AS50151, AS34001 SERIES, CLASS D, E, K, L, U & W: AS34001, AS34011, AS34041, AS34061, AS34501, AS34511, AS34541, AS34561, MS3471, MS3472, MS3474, MS3475, MS3476. MIL-DTL-83723, SERIES II, CLASS A & L. MIL-DTL-83723, SERIES I & III, CLASS A, G, K, R & S: M83723/1, /2, /3, /4, /5, /6, /7, /8, /13, /14, /36, /37, /38, /39, /40, /41, /42, /43, /48, /49, /65, /66, /67, /68, /69, /70, /71, /72, /73, /74, /75, /76, /77, /78, /82, /83, /84, /85, /86, /87, /91, /92, /95, /97, /98, (SAE-AS31551 CONTROLLED INTERFACE).
- THIS PRODUCT IS A FUNCTIONAL EQUIVALENT OF SAE-AS85049/60-2.
- KNURL INSIDE BOOT GROOVE MAY BE SUPPLIED AT MANUFACTURER'S OPTION.

If this document is printed it becomes uncontrolled. Check for the latest revision

©2015 TE CONNECTIVITY LTD. FAMILY OF COMPANIES. ALL RIGHTS RESERVED  
 TE CONNECTIVITY AND TE CONNECTIVITY (LOGO) ARE TRADEMARKS.  
 OTHER LOGOS PRODUCT AND/OR COMPANY NAMES MAY BE TRADEMARKS OF THEIR RESPECTIVE OWNERS.

Raychem Adapters  
 CUSTOMER DRAWING

UNLESS OTHERWISE SPECIFIED DIMENSIONS ARE IN INCHES. REFERENCE METRIC DIMENSIONS ARE IN BRACKETS [metric].	DRAWN: R. RAMIREZ	DATE: 03/18/1993		TE Connectivity			
	CHECKED:	DATE:					
DECIMALS TOLERANCES: XXX ± .005 [0.13mm] XX ± .01 [0.25mm] X ± .1 [0.50mm]	APPROVED: W. C. GAY	DATE: 05/19/1993	TITLE: ADAPTER, SOLID, CODE 54				
ANGLES TOLERANCE: ± 1'	MATERIAL: SEE NOTES	FINISH: SEE NOTES					
SCALE: DO NOT SCALE THIS DRAWING	CAD FILE: 201M9XX.dwg	THIRD ANGLE PROJECTION: 	SIZE: A	SHEET: 1 OF 2	CAGE CODE: 06090	DRAWING NO: 201M9XX	REV. K

BASE PART NO.	SHELL SIZE		A THREAD CLASS 2B	B MAX DIA	Y MAX DIA	X +.008 -.000 [+0.20] [-0.00] DIM	E MAX DIM	Z MIN DIA	F ±.031 [±0.80] DIM
	4	5							
201M903	3		.562-24 UNEF	.709 [18.01]	.752 [19.10]	.044 [1.12]	.540 [13.72]	.255 [6.47]	.406 [10.31]
201M908		8 & 8S	.500-20 UNEF	.657 [16.69]	.688 [17.48]	↑	↑	.255 [6.47]	↑
201M910		10, 10S & 10SL	.625-24 UNEF	.774 [19.66]	.803 [20.40]	↓		.360 [9.14]	
201M912	7	12 & 12S	.750-20 UNEF	.898 [22.81]	.938 [23.83]	↓		.496 [12.60]	
201M914	12	14 & 14S	.875-20 UNEF	1.024 [26.01]	1.063 [27.00]	.044 [1.12]		.570 [14.48]	
201M916	19	16 & 16S	1.000-20 UNEF	1.152 [29.26]	1.238 [31.45]	.069 [1.75]		.695 [17.65]	
201M918	27	18	1.062-18 UNEF	1.243 [31.57]	1.310 [33.27]	↑		.774 [19.66]	
201M920	37	20	1.188-18 UNEF	1.370 [34.80]	1.436 [36.47]	↓		.899 [22.83]	
201M922		22	1.312-18 UNEF	1.443 [36.65]	1.560 [39.62]	↓	↓	1.024 [26.01]	↓
201M924		24	1.438-18 UNEF	1.618 [41.10]	1.686 [42.82]	.069 [1.75]	.540 [13.72]	1.139 [28.93]	.406 [10.31]
201M928		28	1.750-18 UNS	1.969 [50.01]	2.063 [52.40]	.086 [2.18]	.702 [17.83]	1.374 [34.90]	.563 [14.30]
201M932		32	2.000-18 UNS	2.220 [56.40]	2.312 [58.72]	↑	↑	1.620 [41.15]	↑
201M936		36	2.250-16 UN	2.469 [62.71]	2.563 [65.10]	↑		1.835 [46.60]	↑
201M940		40	2.500-16 UN	2.720 [69.10]	2.812 [71.42]	↓	↓	2.050 [52.07]	↓
201M944		44	2.750-16 UN	2.969 [75.41]	3.062 [77.77]	↓	↓	2.305 [58.55]	↓
201M948		48	3.000-16 UN	3.220 [81.80]	3.312 [84.12]	.086 [2.18]	.702 [17.83]	2.555 [64.90]	.563 [14.30]
201M961	61		1.500-18 UNEF	1.654 [42.00]	1.748 [44.40]	.069 [1.75]	.540 [13.72]	1.179 [29.95]	.406 [10.31]

If this document is printed it becomes uncontrolled. Check for the latest revision

**Raychem Adapters  
CUSTOMER DRAWING**



DO NOT  
SCALE THIS  
DRAWING

SIZE  
A

CAGE  
06090

SHEET  
2 OF 2

DWG. NO.

201M9XX

REV  
K



Компания «ЭлектроПласт» предлагает заключение долгосрочных отношений при поставках импортных электронных компонентов на взаимовыгодных условиях!

Наши преимущества:

- Оперативные поставки широкого спектра электронных компонентов отечественного и импортного производства напрямую от производителей и с крупнейших мировых складов;
- Поставка более 17-ти миллионов наименований электронных компонентов;
- Поставка сложных, дефицитных, либо снятых с производства позиций;
- Оперативные сроки поставки под заказ (от 5 рабочих дней);
- Экспресс доставка в любую точку России;
- Техническая поддержка проекта, помощь в подборе аналогов, поставка прототипов;
- Система менеджмента качества сертифицирована по Международному стандарту ISO 9001;
- Лицензия ФСБ на осуществление работ с использованием сведений, составляющих государственную тайну;
- Поставка специализированных компонентов (Xilinx, Altera, Analog Devices, Intersil, Interpoint, Microsemi, Aeroflex, Peregrine, Syfer, Eurofarad, Texas Instrument, Miteq, Cobham, E2V, MA-COM, Hittite, Mini-Circuits, General Dynamics и др.);

Помимо этого, одним из направлений компании «ЭлектроПласт» является направление «Источники питания». Мы предлагаем Вам помощь Конструкторского отдела:

- Подбор оптимального решения, техническое обоснование при выборе компонента;
- Подбор аналогов;
- Консультации по применению компонента;
- Поставка образцов и прототипов;
- Техническая поддержка проекта;
- Защита от снятия компонента с производства.



#### Как с нами связаться

**Телефон:** 8 (812) 309 58 32 (многоканальный)

**Факс:** 8 (812) 320-02-42

**Электронная почта:** [org@eplast1.ru](mailto:org@eplast1.ru)

**Адрес:** 198099, г. Санкт-Петербург, ул. Калинина, дом 2, корпус 4, литера А.