



SANYO Semiconductors

DATA SHEET

An ON Semiconductor Company

LB1936V — 1-2 Phase Excitation Stepping Motor Driver

Monolithic Digital IC

Overview

The LB1936V is a 2-phase bipolar drive stepping motor driver IC that supports low-voltage drive. The LB1936V's miniature package and minimal number of external components reduces the required mounting area. It also provides high-efficiency motor drive and can reduce circuit current consumption. Since it provides a current detection pin and supports PWM control input, it can be used to implement current chopper control at the system level. The LB1936V is optimal for the stepping motor drive in scanners, digital cameras, and printers.

Features

- Low saturation voltage forward/reverse motor driver ($V_O \text{ sat} = 0.25\text{V}$ at $I_O = 200\text{mA}$)
- Two H-bridge channels
- Wide usable voltage range (Allowable voltage range : 2.5V to 9.5V, absolute maximum rating : 10.5V)
- Supports PWM input (Low power consumption can be achieved in slow delay mode that uses $IN1/IN2 = H/H$ logic.)
- Motor (coil) current detection pin
- Built-in thermal shutdown circuit
- Miniature package (SSOP16 : 225mil)

Specifications

Absolute Maximum Ratings at $T_a = 25^\circ\text{C}$

Parameter	Symbol	Conditions	Ratings	Unit
Maximum supply voltage	$V_{CC} \text{ max}$		-0.3 to +10.5	V
	$V_S \text{ max}$		-0.3 to +10.5	V
Maximum output voltage	$V_{OUT} \text{ max}$		$V_S + V_{SF}$	V
Maximum input voltage	$V_{IN} \text{ max}$		-0.3 to +8.0	V
Ground pin source current	$I_{GND} \text{ max}$	Per channel	800	mA
Allowable power dissipation	$P_d \text{ max}$	When mounted on a circuit board *	740	mW
Operating temperature	T_{opr}		-20 to +85	$^\circ\text{C}$
Storage temperature	T_{stg}		-40 to +150	$^\circ\text{C}$

* Specified circuit board : $114.3 \times 76.1 \times 1.6\text{mm}^3$, glass epoxy

■ Any and all SANYO Semiconductor Co.,Ltd. products described or contained herein are, with regard to "standard application", intended for the use as general electronics equipment (home appliances, AV equipment, communication device, office equipment, industrial equipment etc.). The products mentioned herein shall not be intended for use for any "special application" (medical equipment whose purpose is to sustain life, aerospace instrument, nuclear control device, burning appliances, transportation machine, traffic signal system, safety equipment etc.) that shall require extremely high level of reliability and can directly threaten human lives in case of failure or malfunction of the product or may cause harm to human bodies, nor shall they grant any guarantee thereof. If you should intend to use our products for applications outside the standard applications of our customer who is considering such use and/or outside the scope of our intended standard applications, please consult with us prior to the intended use. If there is no consultation or inquiry before the intended use, our customer shall be solely responsible for the use.

■ Specifications of any and all SANYO Semiconductor Co.,Ltd. products described or contained herein stipulate the performance, characteristics, and functions of the described products in the independent state, and are not guarantees of the performance, characteristics, and functions of the described products as mounted in the customer's products or equipment. To verify symptoms and states that cannot be evaluated in an independent device, the customer should always evaluate and test devices mounted in the customer's products or equipment.

SANYO Semiconductor Co., Ltd.

TOKYO OFFICE Tokyo Bldg., 1-10, 1 Chome, Ueno, Taito-ku, TOKYO, 110-8534 JAPAN

LB1936V

Allowable Operating Range at $T_a = 25^\circ\text{C}$

Parameter	Symbol	Conditions	Ratings	Unit
Supply voltage	V_{CC}		2.5 to 9.5	V
	V_S		2.5 to 9.5	
High-level input voltage	V_{IH}		2.0 to 7.5	V
Low-level input voltage	V_{IL}		-0.3 to 0.7	V

Electrical Characteristics at $T_a = 25^\circ\text{C}$, $V_{CC} = V_S = 5\text{V}$

Parameter	Symbol	Conditions	Ratings			Unit
			min	typ	max	
V_{CC} system power supply current	I_{CC0}	$IN1 = IN2 = IN3 = IN4 = 0\text{V}$		0.1	1	μA
	I_{CC1}	$IN1 = IN3 = 3\text{V}$, $IN2 = IN4 = 0\text{V}$		10	16	mA
VS system power supply current	I_{S0}	$IN1 = IN2 = IN3 = IN4 = 0\text{V}$		0.1	1	μA
	I_{S1}	$IN1 = IN3 = 3\text{V}$, $IN2 = IN4 = 0\text{V}$		12	19	mA
Output saturation voltage	V_{OUT1}	$V_{CC} = V_S = 3\text{V to } 7.5\text{V}$, $V_{IN} = 3\text{V or } 0\text{V}$, $I_{OUT} = 200\text{mA}$ (High and low side)	-	0.25	0.4	V
	V_{OUT2}	$V_{CC} = V_S = 4\text{V to } 7.5\text{V}$, $V_{IN} = 3\text{V or } 0\text{V}$, $I_{OUT} = 400\text{mA}$ (High and low side)	-	0.5	0.8	V
Input current	I_{IN}	$V_{IN} = 5\text{V}$		150	200	μA
Spark killer diode						
Reverse current	$I_S(\text{leak})$				30	μA
Forward voltage	VSF	$I_{OUT} = 400\text{mA}$			1.7	V

Package Dimensions

unit:mm (typ)

3178B

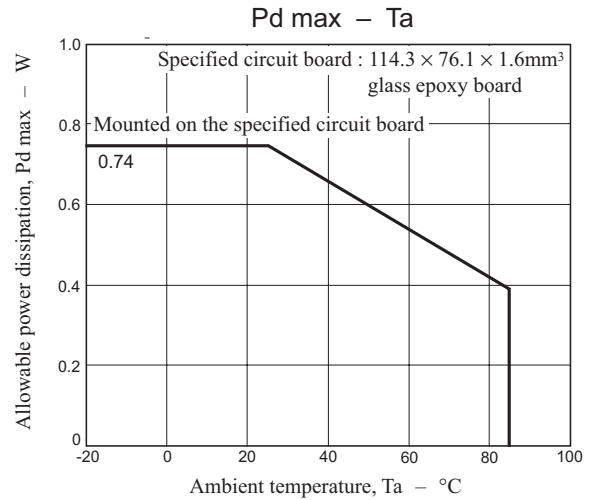
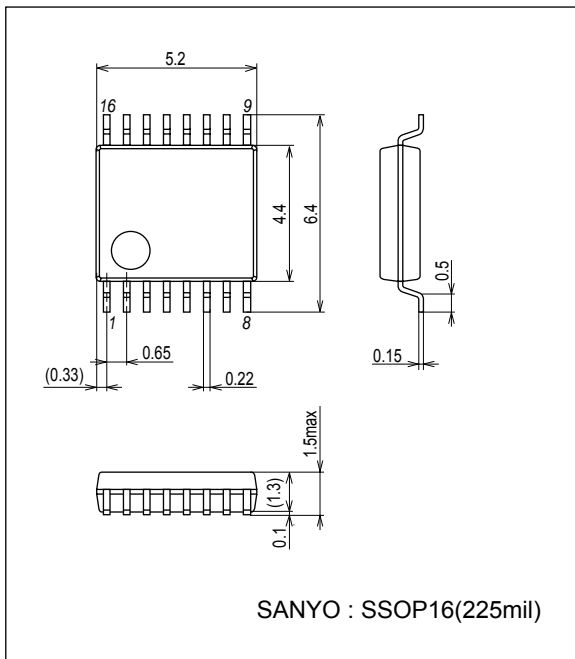

LB1936V

Pin Assignment

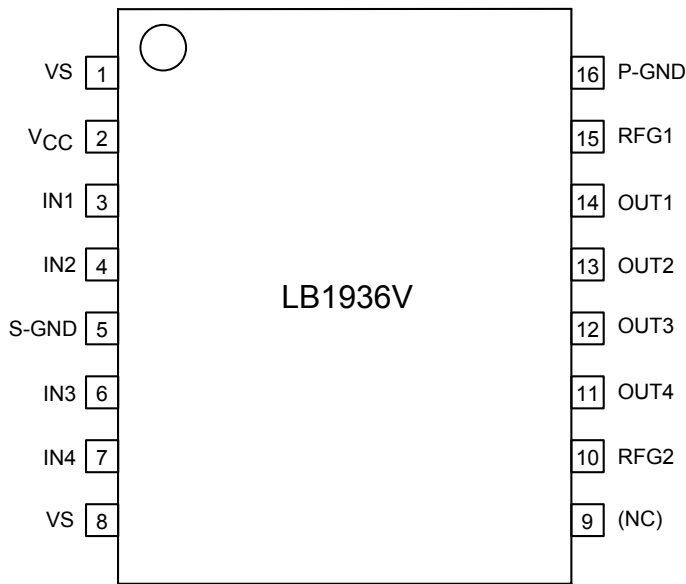

Top view

Block Diagram

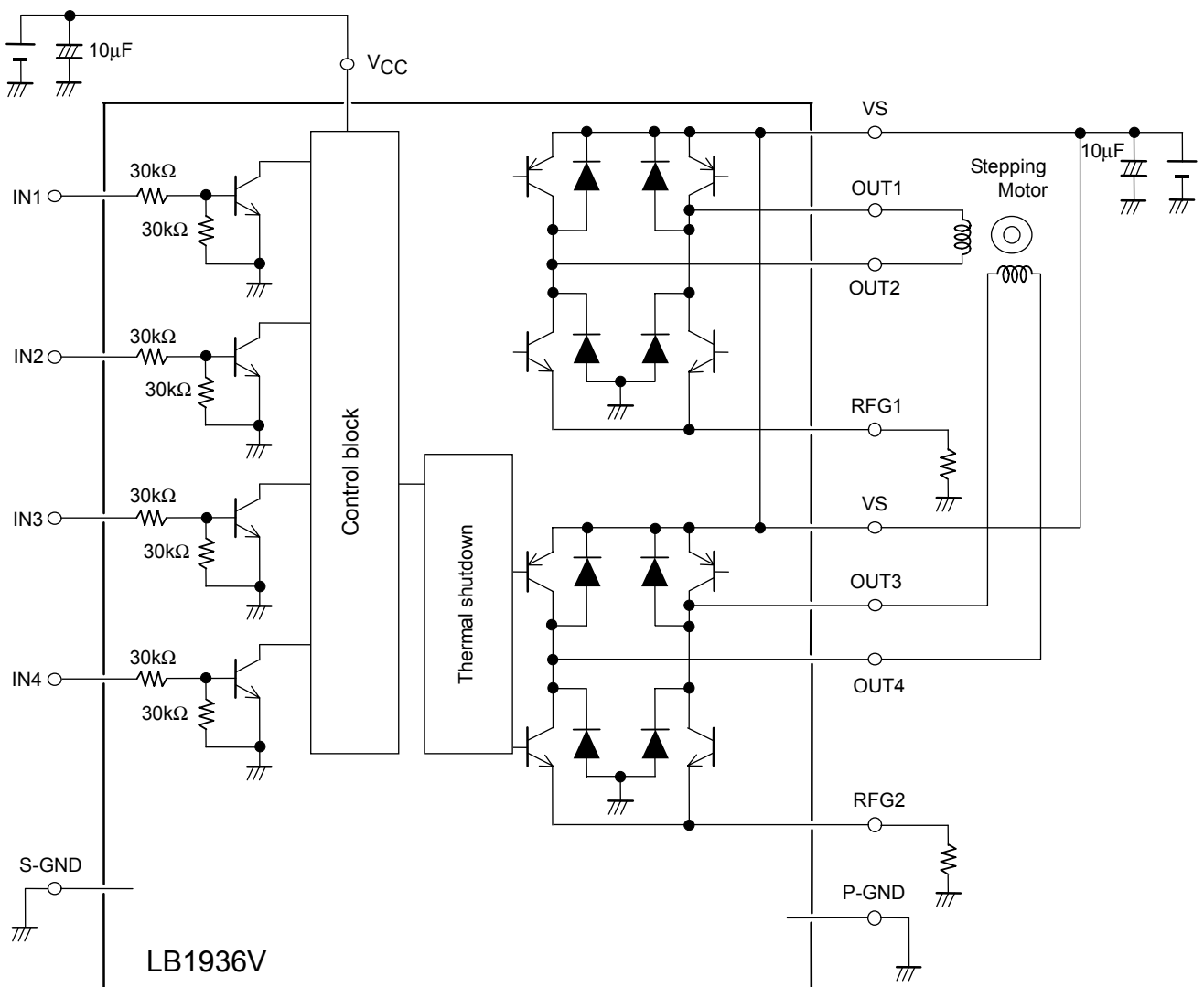

LB1936V

Truth Table

IN1	IN2	IN3	IN4	OUT1	OUT2	OUT3	OUT4	Output mode
L	L	-	-	off	off	-	-	(1)
L	H			L	H			(2)
H	L			H	L			(3)
H(*)	H(*)			off	H			(4)
				H	off			(4)'
-	-	L	L	-	-	off	off	(5)
		L	H			L	H	(6)
		H	L			H	L	(7)
		H(*)	H(*)			off	H	(8)
						H	off	(8)'

L : low, H : high

*: The output logic mode when IN1/IN2 = H/H is determined by the immediately preceding IN1/IN2 mode.

The post-switching output modes will be as follows.

When switching from (2): (4)

When switching from (3): (4)'

When switching from (1): Undefined (Either (4) or (4)')

The modes when IN3/IN4 = H/H operate similarly as described below.

When switching from (6): (8)

When switching from (7): (8)'

When switching from (5): Undefined (Either (8) or (8)')

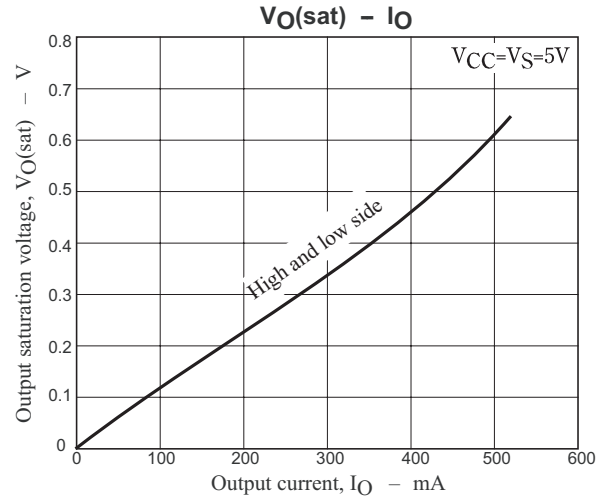
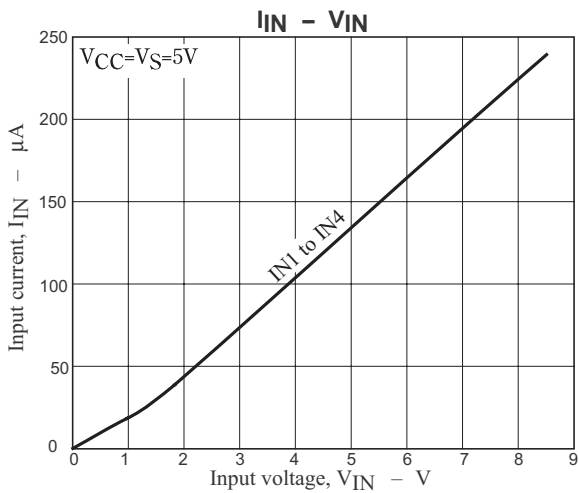
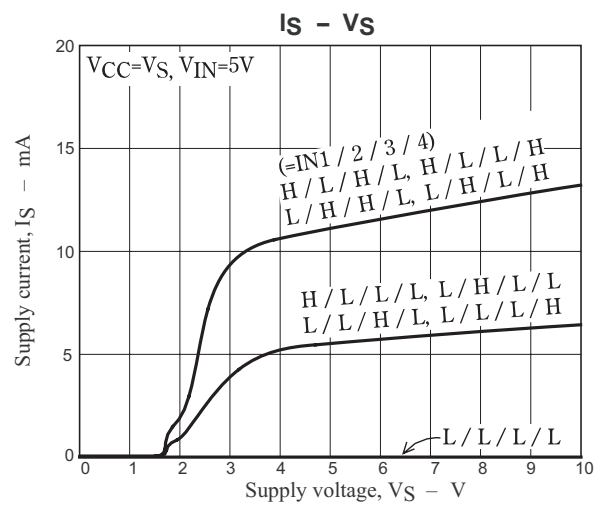
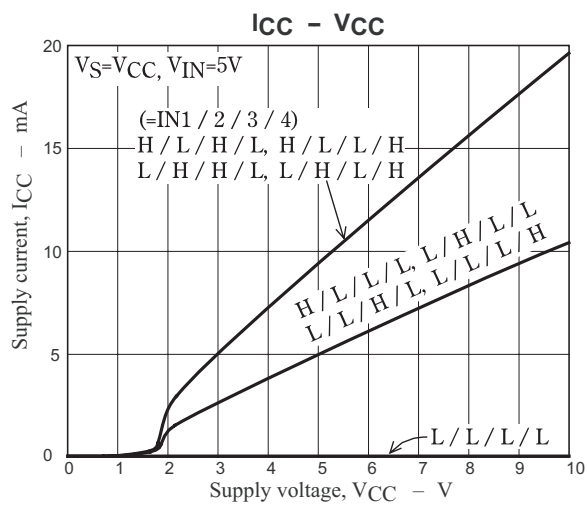

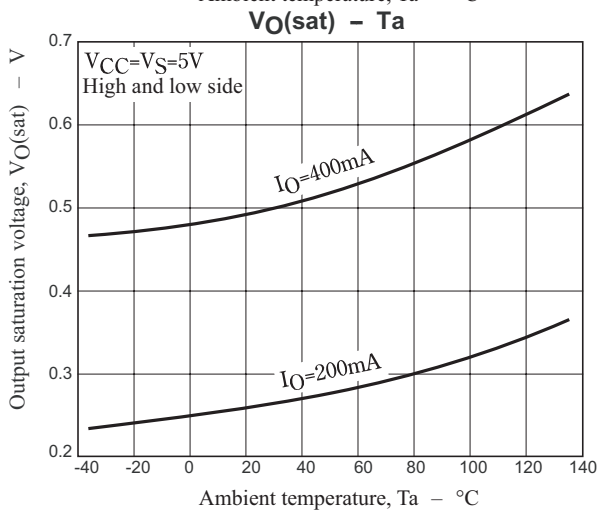
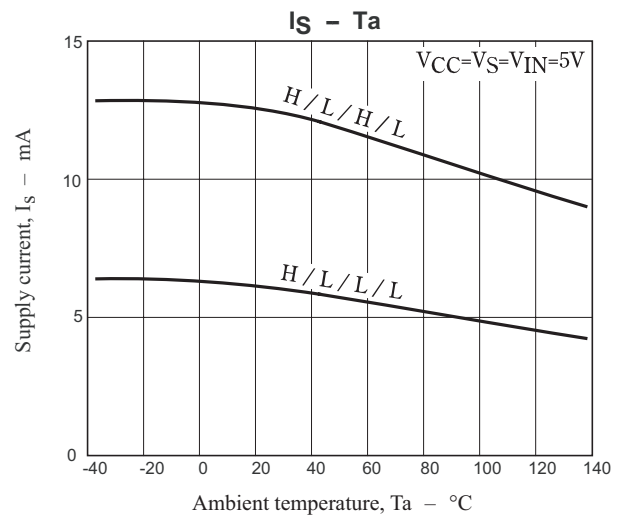
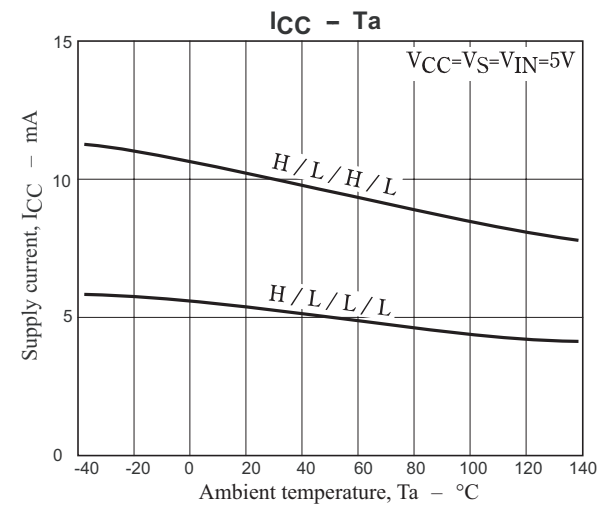

- SANYO Semiconductor Co.,Ltd. assumes no responsibility for equipment failures that result from using products at values that exceed, even momentarily, rated values (such as maximum ratings, operating condition ranges, or other parameters) listed in products specifications of any and all SANYO Semiconductor Co.,Ltd. products described or contained herein.
- SANYO Semiconductor Co.,Ltd. strives to supply high-quality high-reliability products, however, any and all semiconductor products fail or malfunction with some probability. It is possible that these probabilistic failures or malfunction could give rise to accidents or events that could endanger human lives, trouble that could give rise to smoke or fire, or accidents that could cause damage to other property. When designing equipment, adopt safety measures so that these kinds of accidents or events cannot occur. Such measures include but are not limited to protective circuits and error prevention circuits for safe design, redundant design, and structural design.
- In the event that any or all SANYO Semiconductor Co.,Ltd. products described or contained herein are controlled under any of applicable local export control laws and regulations, such products may require the export license from the authorities concerned in accordance with the above law.
- No part of this publication may be reproduced or transmitted in any form or by any means, electronic or mechanical, including photocopying and recording, or any information storage or retrieval system, or otherwise, without the prior written consent of SANYO Semiconductor Co.,Ltd.
- Any and all information described or contained herein are subject to change without notice due to product/technology improvement, etc. When designing equipment, refer to the "Delivery Specification" for the SANYO Semiconductor Co.,Ltd. product that you intend to use.
- Information (including circuit diagrams and circuit parameters) herein is for example only; it is not guaranteed for volume production.
- Upon using the technical information or products described herein, neither warranty nor license shall be granted with regard to intellectual property rights or any other rights of SANYO Semiconductor Co.,Ltd. or any third party. SANYO Semiconductor Co.,Ltd. shall not be liable for any claim or suits with regard to a third party's intellectual property rights which has resulted from the use of the technical information and products mentioned above.

This catalog provides information as of April, 2007. Specifications and information herein are subject to change without notice.



Компания «ЭлектроПласт» предлагает заключение долгосрочных отношений при поставках импортных электронных компонентов на взаимовыгодных условиях!

Наши преимущества:

- Оперативные поставки широкого спектра электронных компонентов отечественного и импортного производства напрямую от производителей и с крупнейших мировых складов;
- Поставка более 17-ти миллионов наименований электронных компонентов;
- Поставка сложных, дефицитных, либо снятых с производства позиций;
- Оперативные сроки поставки под заказ (от 5 рабочих дней);
- Экспресс доставка в любую точку России;
- Техническая поддержка проекта, помощь в подборе аналогов, поставка прототипов;
- Система менеджмента качества сертифицирована по Международному стандарту ISO 9001;
- Лицензия ФСБ на осуществление работ с использованием сведений, составляющих государственную тайну;
- Поставка специализированных компонентов (Xilinx, Altera, Analog Devices, Intersil, Interpoint, Microsemi, Aeroflex, Peregrine, Syfer, Eurofarad, Texas Instrument, Miteq, Cobham, E2V, MA-COM, Hittite, Mini-Circuits, General Dynamics и др.);

Помимо этого, одним из направлений компании «ЭлектроПласт» является направление «Источники питания». Мы предлагаем Вам помощь Конструкторского отдела:

- Подбор оптимального решения, техническое обоснование при выборе компонента;
- Подбор аналогов;
- Консультации по применению компонента;
- Поставка образцов и прототипов;
- Техническая поддержка проекта;
- Защита от снятия компонента с производства.



Как с нами связаться

Телефон: 8 (812) 309 58 32 (многоканальный)

Факс: 8 (812) 320-02-42

Электронная почта: org@eplast1.ru

Адрес: 198099, г. Санкт-Петербург, ул. Калинина, дом 2, корпус 4, литера А.