



Disc Type Capacitors with Lead

High Voltage Ceramic Capacitors

Automotive Grade, Safety Standard Approved

CS series

Type: CS [SL, B, Z5U characteristics, Eac: X1:440V, Y2:300V]



REMINDERS FOR USING THESE PRODUCTS

Before using these products, be sure to request the delivery specifications.

SAFETY REMINDERS

Please pay sufficient attention to the warnings for safe designing when using these products.

REMINDERS

- Do not use or store in locations where there are conditions such as gas corrosion (salt, acid, alkali, etc.).
- Before soldering, be sure to preheat components.
The preheating temperature should be set so that the temperature difference between the solder temperature and product temperature does not exceed 150°C.
- Soldering corrections after mounting should be within the range of the conditions determined in the specifications.
If overheated, a short circuit, performance deterioration, or lifespan shortening may occur.
- Self heating (temperature increase) occurs when the power is turned ON, so the tolerance should be sufficient for the set thermal design.
- Do not use for a purpose outside of the contents regulated in the delivery specifications.

- The products listed on this catalog are intended for use in automotive electronic equipment under a normal operation and use condition.

The products are not designed or warranted to meet the requirements of the applications listed below, whose performance and/or quality require a more stringent level of safety or reliability, or whose failure, malfunction or trouble could cause serious damage to society, person or property.

If you intend to use the products in the applications listed below or if you have special requirements exceeding the range or conditions set forth in the each catalog, please contact us.

- | | |
|---|--|
| (1) Aerospace/Aviation equipment | (8) Public information-processing equipment |
| (2) Transportation equipment (electric trains, ships, etc.) | (9) Military equipment |
| (3) Medical equipment | (10) Electric heating apparatus, burning equipment |
| (4) Power-generation control equipment | (11) Disaster prevention/crime prevention equipment |
| (5) Atomic energy-related equipment | (12) Safety equipment |
| (6) Seabed equipment | (13) Other applications that are not considered general-purpose applications |
| (7) Transportation control equipment | |

- Please refer to the guideline of notabilia for fixed ceramic capacitors issued by JEITA(Japan Electronics and Information Technology Association, EIAJ RCR-2335).

When designing your equipment even for automotive-purpose applications, you are kindly requested to take into consideration securing protection circuit/device or providing backup circuits in your equipment.

Disc Type Capacitors with Lead

Product compatible with RoHS directive
Halogen-free

High Voltage Ceramic Capacitors, Automotive Grade, Safety Standard Approved

Overview of CS Series

FEATURES

- AEC-Q200 compliant.
- 1,000 cycles guaranteed under heat shock testing at -55°C to $+125^{\circ}\text{C}$.
- It can be used as a Y capacitor for battery chargers used in automobiles (EV, PHEV).
- Compliant with IEC and the safety standards of various countries.
- Rated at a withstand voltage of AC.2600V.
- These products shall conform to RoHS Directive due to lead(Pb) free of lead wire and internal solder material.
- Compatible with halogen-free external resin coating.

APPLICATION

For use in Y capacitor for battery chargers or air-conditioners used in automobiles.

PART NUMBER CONSTRUCTION

CS	80	ZU	2GA	222	M	A	□	K	A						
Series name	Type*	Temperature characteristics	Rated voltage	Nominal capacitance	Capacitance tolerance	Grade classification	Lead type	Application classification	Internal code						
45	SL	+350 to -1000ppm/°C	2GA X1:440V Y2:300V	100	10pF	J	±5%	A	For use in automobiles	G	Long lead	K	Safety standard	A	Halogen-free
65				221	220pF	K	±10%			N	Short lead				
70	B	±10%		472	4,700pF	M	±20%			V	Taping				
75	ZU (Z5U)	+22, -56%													
80															
85															
95															
11															

* Please refer to P-6~8 about the product dimensions.

OPERATING TEMPERATURE RANGE

Capacitance temperature characteristics	Temperature range*	
	Operating temperature (°C)	Storage temperature** (°C)
SL	-25 to +125	-25 to +125
B	-25 to +125	-25 to +125
Z5U	-25 to +125	-25 to +125

* The maximum operating temperature of 125°C includes capacitor self-generated heat of up to 20°C .

** The storage temperature range applies to after MLCC is mounted on board.

- RoHS Directive Compliant Product: See the following for more details related to RoHS Directive compliant products. <http://product.tdk.com/en/environment/rohs/>
- Halogen-free: Indicates that Cl content is less than 900ppm, Br content is less than 900ppm, and that the total Cl and Br content is less than 1500ppm.

 Please be sure to request delivery specifications that provide further details on the features and specifications of the products for proper and safe use. Please note that the contents may change without any prior notice due to reasons such as upgrading.

Overview of CS Series

PACKAGE QUANTITY

Type	Package quantity	
	Taping (pieces / box)	Bulk (pieces / bag)
CS	1000	1000

CERTIFIED STATUS OF VARIOUS COUNTRIES

Safety standard	Standard No.	Temperature characteristics	Insulation sub-class and rated voltage	Approval report No.*	
				Taiwan	Xiamen
BSI	BS EN60384-14	SL, B, Z5U	X1: AC.440V Y2: AC.300V		KM37103
VDE	IEC 60384-14			40017930	
SEV	IEC 60384-14			15.0120	
SEMKO	EN 60384-14			1406932	
NEMKO	EN 60384-14			P12215336	
DEMKO	EN 60384-14			D-01153	
FIMKO	EN 60384-14			FI 27399	
IMQ	EN 60384-14			V3692	
SAA	AS 3250			CS6268	
CSA	CSA-E60384-14			1785515	
UL	UL60384-14			E37861	
CQC	GB/T14472-1998			CQC12001082619	CQC10001052862
					Sub-Class:X1
		SZ03001-12006	SU03047-12006		
			Sub-Class:Y2		
		SZ03001-12008	SU03047-12008		
KTL	K60384-14				

* Certificate numbers shall be changed owing to the revisions of the related standards.

Overview of CS Series

RECOMMENDED FLOW PROFILE

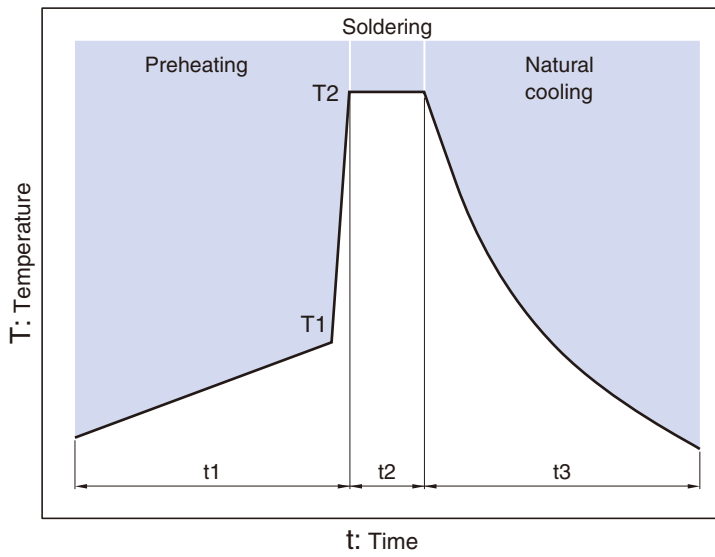

Preheating		Peak		Natural cooling
Temp.	Time	Temp.	Time	Time
T1	t1	T2	t2	t3
110°C min.	30 to 60s.	260°C	Within 10s.	Over 60s.

CS45 Type

CAPACITANCE AND DIMENSIONS

□ Temperature Characteristics: SL (+350 to -1000ppm/°C)

□ Rated Voltage Edc: X1:440V, Y2:300V

Capacitance (pF)	Capacitance tolerance	Dimensions (mm)		F (Applied to bulk)	F (Applied to taping)	d	Part No.*
		D max.	T max.				
10	±5%	7.0	7.0	7.5±1.5	7.5±0.8	0.6±0.05	CS45SL2GA100JA□KA**
15	±5%	7.0	7.0	7.5±1.5	7.5±0.8	0.6±0.05	CS45SL2GA150JA□KA
22	±5%	7.0	7.0	7.5±1.5	7.5±0.8	0.6±0.05	CS45SL2GA220JA□KA
33	±5%	7.0	7.0	7.5±1.5	7.5±0.8	0.6±0.05	CS45SL2GA330JA□KA
47	±5%	8.0	7.0	7.5±1.5	7.5±0.8	0.6±0.05	CS45SL2GA470JA□KA
68	±5%	9.0	7.0	7.5±1.5	7.5±0.8	0.6±0.05	CS45SL2GA680JA□KA

* The part numbers are TDK's standard specification products.

** The "□" of the Part Number contains the lead type, G, N or V. Please refer to the details of each shape is shown below.

• Please refer to P-9 about the taping dimensions.

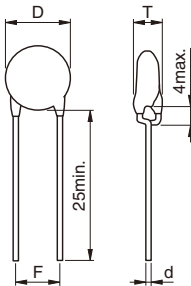
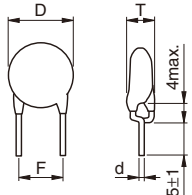
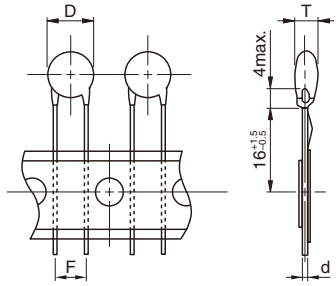

LIST OF STANDARD LEAD SHAPES

	Symbol G Bulk/Long lead	Symbol N Bulk/Short lead	Symbol V Taping
Vertical kink			

• TDK's standard product is vertical kink.

• TDK's recommendation is short lead type with the symbol N for bulk products.

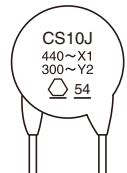
MARKINGS

Item	Markings	Specifications	Marking examples
1. Series	CS	CS series	
2. Nominal capacitance	10	10pF	
3. Capacitance tolerance	J	±5%	
4. Rated voltage Eac	440~X1 300~Y2	X1: AC.440V Y2: AC.300V	
5. TDK's logogram		Production base code	
6. Date code	54	2015.4*	
7. Applications	—	For use in automobiles	

(Underscore below date of production) (Marking position is reference.)

* Year and month of production: last digit of year + month denoted by 1, 2, 3, 4, 5, 6, 7, 8, 9, O (October), N (November), or D (December).

* The expression has become simplified due to a revision in the standards.

CS65,70,75,85 Type

CAPACITANCE AND DIMENSIONS

- Temperature Characteristics: B ($\pm 10\%$)
- Rated Voltage Edc: X1:440V, Y2:300V

Capacitance (pF)	Capacitance tolerance	Dimensions (mm)		F (Applied to bulk)	F (Applied to taping)	d	Part No.*
		D max.	T max.				
100	$\pm 10\%$	7.0	7.0	7.5 ± 1.5	7.5 ± 0.8	0.6 ± 0.05	CS65-B2GA101KA□KA**
150	$\pm 10\%$	7.0	7.0	7.5 ± 1.5	7.5 ± 0.8	0.6 ± 0.05	CS65-B2GA151KA□KA
220	$\pm 10\%$	7.0	7.0	7.5 ± 1.5	7.5 ± 0.8	0.6 ± 0.05	CS65-B2GA221KA□KA
330	$\pm 10\%$	7.5	7.0	7.5 ± 1.5	7.5 ± 0.8	0.6 ± 0.05	CS70-B2GA331KA□KA
470	$\pm 10\%$	9.0	7.0	7.5 ± 1.5	7.5 ± 0.8	0.6 ± 0.05	CS75-B2GA471KA□KA
680	$\pm 10\%$	9.5	7.0	7.5 ± 1.5	7.5 ± 0.8	0.6 ± 0.05	CS85-B2GA681KA□KA

* The part numbers are TDK's standard specification products.

** The "□" of the Part Number contains the lead type, G, N or V. Please refer to the details of each shape is shown below.

• Please refer to P-9 about the taping dimensions.

LIST OF STANDARD LEAD SHAPES

	Symbol G Bulk/Long lead	Symbol N Bulk/Short lead	Symbol V Taping
Vertical kink			

• TDK's standard product is vertical kink.

• TDK's recommendation is short lead type with the symbol N for bulk products.

MARKINGS

Item	Markings	Specifications	Marking examples
1. Series	CS	CS series	
2. Nominal capacitance	101	100pF	
3. Capacitance tolerance	K	$\pm 10\%$	
4. Rated voltage Eac	440~X1 300~Y2	X1: AC.440V Y2: AC.300V	
5. TDK's logogram		Production base code	
6. Date code	54	2015.4*	
7. Applications	—	For use in automobiles	
(Underscore below date of production)			(Marking position is reference.)

* Year and month of production: last digit of year + month denoted by 1, 2, 3, 4, 5, 6, 7, 8, 9, O (October), N (November), or D (December).

* The expression has become simplified due to a revision in the standards.

CS65,75,80,95,11 Type

CAPACITANCE AND DIMENSIONS

□ Temperature Characteristics: Z5U (+22, -56%)

□ Rated Voltage Edc: X1:440V, Y2:300V

Capacitance (pF)	Capacitance tolerance	Dimensions (mm)		F (Applied to bulk)	F (Applied to taping)	d	Part No.*
		D max.	T max.				
1,000	±20%	7.0	7.0	7.5±1.5	7.5±0.8	0.6±0.05	CS65ZU2GA102MA□KA**
1,500	±20%	8.0	7.0	7.5±1.5	7.5±0.8	0.6±0.05	CS75ZU2GA152MA□KA
2,200	±20%	9.5	7.0	7.5±1.5	7.5±0.8	0.6±0.05	CS80ZU2GA222MA□KA
3,300	±20%	12.0	7.0	7.5±1.5	7.5±0.8	0.6±0.05	CS95ZU2GA332MA□KA
4,700	±20%	13.5	7.0	7.5±1.5	7.5±0.8	0.6±0.05	CS11ZU2GA472MA□KA

* The part numbers are TDK's standard specification products.

** The "□" of the Part Number contains the lead type, G, N or V. Please refer to the details of each shape is shown below.

• Please refer to P-9 about the taping dimensions.

LIST OF STANDARD LEAD SHAPES

Dimensions in mm

	Symbol G Bulk/Long lead	Symbol N Bulk/Short lead	Symbol V Taping
Vertical kink			

• TDK's standard product is vertical kink.

• TDK's recommendation is short lead type with the symbol N for bulk products.

MARKINGS

Item	Markings	Specifications	Marking examples
1. Series	CS	CS series	<p>(Marking position is reference.)</p>
2. Nominal capacitance	102	1000pF	
3. Capacitance tolerance	M	±20%	
4. Rated voltage Eac	440~X1 300~Y2	X1: AC.440V Y2: AC.300V	
5. TDK's logogram		Production base code	
6. Date code	54	2015.4*	
7. Applications	— (Underscore below date of production)	For use in automobiles	

* Year and month of production: last digit of year + month denoted by 1, 2, 3, 4, 5, 6, 7, 8, 9, O (October), N (November), or D (December).

* The expression has become simplified due to a revision in the standards.

CS Series

TAPING DIMENSIONS

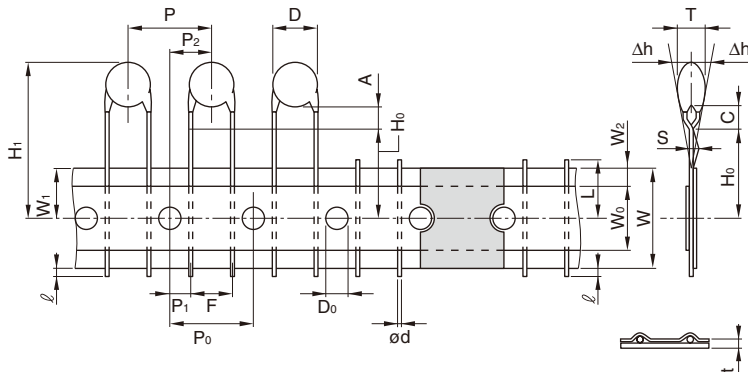

Item	Symbol	Dimensions(mm)	Remarks
Body diameter	D	Depends on the specification of each product.	
Body thickness	T	Depends on the specification of each product.	
Lead-wire diameter	ød	0.6±0.05	
Pitch of component	P	15.0±1.0	Including the slant of body
Feed hole pitch	P ₀	15.0±0.3	Excepting the tape splicing part
Feed hole center to lead	P ₁	3.75±0.7	
Feed hole center to component center	P ₂	7.5±1.3	
Lead-to lead distance	F	7.5±0.8	Measuring point is bottom kink
Component alignment	Δh	0±2.0	Including the slanting body due to bending lead-wire
Tape width	W	18.0+1.0, -0.5	
Adhesive tape width	W ₀	10.0min.	
Hole position	W ₁	9.0±0.5	
Adhesive tape position	W ₂	4.0max.	Adhesive tape do not stick out the tape
Bottom of kink from tape center	H ₀	16.0+1.5, -0.5	
Height of body from tape center	H ₁	46.0max.	
Lead-wire protrusion	ℓ	1.0max.	
Feed hole diameter	D ₀	4.0±0.2	
Total tape thickness	t	0.6±0.3	Including adhesive tape
Length of snipped lead	L	11.0max.	
Coating on lead	C	4.0max.	
Height of kink	A	4.0max.	Measuring point is bottom kink
Spring action	S	2.0max.	

AMMO PACK INNER BOX SIZE

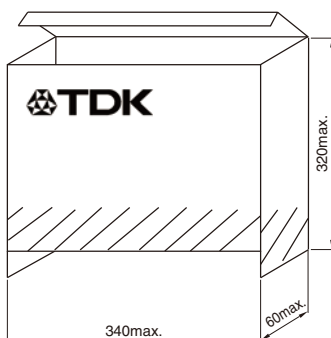

Dimensions in mm

• For more information about products with other capacitance or other data, please contact us.

Please be sure to request delivery specifications that provide further details on the features and specifications of the products for proper and safe use. Please note that the contents may change without any prior notice due to reasons such as upgrading.



Компания «ЭлектроПласт» предлагает заключение долгосрочных отношений при поставках импортных электронных компонентов на взаимовыгодных условиях!

Наши преимущества:

- Оперативные поставки широкого спектра электронных компонентов отечественного и импортного производства напрямую от производителей и с крупнейших мировых складов;
- Поставка более 17-ти миллионов наименований электронных компонентов;
- Поставка сложных, дефицитных, либо снятых с производства позиций;
- Оперативные сроки поставки под заказ (от 5 рабочих дней);
- Экспресс доставка в любую точку России;
- Техническая поддержка проекта, помощь в подборе аналогов, поставка прототипов;
- Система менеджмента качества сертифицирована по Международному стандарту ISO 9001;
- Лицензия ФСБ на осуществление работ с использованием сведений, составляющих государственную тайну;
- Поставка специализированных компонентов (Xilinx, Altera, Analog Devices, Intersil, Interpoint, Microsemi, Aeroflex, Peregrine, Syfer, Eurofarad, Texas Instrument, Miteq, Cobham, E2V, MA-COM, Hittite, Mini-Circuits, General Dynamics и др.);

Помимо этого, одним из направлений компании «ЭлектроПласт» является направление «Источники питания». Мы предлагаем Вам помощь Конструкторского отдела:

- Подбор оптимального решения, техническое обоснование при выборе компонента;
- Подбор аналогов;
- Консультации по применению компонента;
- Поставка образцов и прототипов;
- Техническая поддержка проекта;
- Защита от снятия компонента с производства.



Как с нами связаться

Телефон: 8 (812) 309 58 32 (многоканальный)

Факс: 8 (812) 320-02-42

Электронная почта: org@eplast1.ru

Адрес: 198099, г. Санкт-Петербург, ул. Калинина, дом 2, корпус 4, литера А.