

1SP0635V / 1SP0635S / 1SP0635D

Preliminary Description & Application Manual

Driver solution for high-voltage and high-power IGBT modules with fiber-optic interface for 2-level, 3-level and multilevel converter topologies with paralleling capability of IGBT modules

Abstract

1SP0635 are single-channel drivers for the reliable driving of up to four paralleled high-voltage and high-power IGBT modules. The driver concept is based on a master-slave principle:

- 1SP0635V (master) is equipped with versatile fiber-optic links (AVAGO HFBR-x522ETZ)
- 1SP0635S (master) is equipped with ST fiber-optic links (AVAGO HFBR-x412Z)
- 1SP0635D (slave) is directly connected to a master or slave driver via a paralleling interface.

The drivers are based on CONCEPT's SCALE™-2 chipset, a highly integrated technology for the reliable driving and safe operation of IGBTs.

Perfectly matched driver versions are available for all mechanically compatible IGBT modules. The plug-and-play capability of the driver allows immediate operation after mounting. The user needs invest no effort in designing or adjusting it to a specific application.



Fig. 1 1SP0635V (master, left) with 1SP0635D (slave, right) each screwed onto a 3.3kV IGBT module

Preliminary Description and Application Manual

Contents

System Overview 4

- 1. 1SP0635V/1SP0635S (Master)..... 4
- 2. 1SP0635D (Slave)..... 5
- 3. Parallel connection of IGBT modules with master and slave(s)..... 6

The Five Steps to Success 6

- 1. Choose a suitable driver 6
- 2. Attach the drivers to the IGBT modules (one driver per IGBT module) 7
- 3. Connect the driver to the control electronics 7
- 4. Check the driver function..... 7
- 5. Set up and test the power stack..... 7

Mechanical Dimensions 8

- 1. 1SP0635V (Master) 8
- 2. 1SP0635S (Master) 9
- 3. 1SP0635D (Slave)..... 10

Recommended Cables and PCB Connectors..... 11

Pin Designation of Connector X1 (Power Supply of 1SP0635V/1SP0635S)..... 12

Description of Interface X1 (Power Supply of 1SP0635V/1SP0635S) 12

Description of the Fiber-Optic Input (1SP0635V/1SP0635S) 12

Description of the Fiber-Optic Output (1SP0635V/1SP0635S) 12

Recommended Interface Circuitry for Fiber Optics (1SP0635V/1SP0635S)..... 15

Description of Paralleling Interfaces X2 and X3 16

LED-Status Indicators 16

How Do 1SP0635V and 1SP0635S SCALE-2 Drivers Work in Detail (Masters)? 16

- Overview 16
- Power supply and electrical isolation 17
- Power-supply monitoring..... 17
- V_{ce} monitoring / short-circuit protection 18
- Gate monitoring 18

How Do 1SP0635D Drivers Work in Detail (Slaves)?..... 19

- Overview 19
- Power supply and electrical isolation 19
- Power-supply monitoring..... 19
- V_{ce} monitoring / short-circuit protection 20
- Gate monitoring 20

Preliminary Description and Application Manual

General Considerations using 1SP0635V/1SP0635S/1SP0635D	20
Parallel connection of IGBT modules using 1SP0635 drivers	20
Dynamic behavior of IGBTs	22
Turn-on of the IGBT / commutation of diode current	22
Turn-off of the IGBT	22
Dynamic Advanced Active Clamping DA ² C	22
Low-inductance layout	24
3-level and multilevel topologies	24
Higher requirements for traction applications or similar	24
References	25
The Information Source: SCALE-2 Driver Data Sheets	26
Quite Special: Customized SCALE-2 Drivers	26
Technical Support	26
Quality	26
Legal Disclaimer	26
Ordering Information	27
Information about Other Products	27
Manufacturer	27

Preliminary Description and Application Manual

System Overview

The 1SP0635 are plug-and-play drivers based on the highly integrated SCALE-2 chipset developed by CONCEPT /1/. This is a set of application-specific integrated circuits (ASICs) that cover the main range of functions needed to design intelligent gate drivers. The SCALE-2 driver chipset is a further development of the proven SCALE technology /2/.

1SP0635 drivers are specifically designed for the reliable and safe driving of high-voltage and high-power IGBT modules from the 1200V to the 3300V voltage class. The driver concept relies on a master-slave principle that allows the safe operation of parallel connected IGBT modules. The master (1SP0635V or 1SP0635S) can be used as a standalone driver without a slave to drive IGBT modules without parallel connection or it can be used with one to three 1SP0635D slaves to drive up to four parallel-connected IGBT modules. The following sections explain the basic topology of the 1SP0635V or 1SP0635S (master), the 1SP0635D (slave) as well as the parallel operation of master and slave(s).

1. 1SP0635V/1SP0635S (Master)

The basic topology of the 1SP0635V and 1SP0635S drivers is shown in Fig. 2. The same driver can be used as a standalone driver without a slave or with up to three slaves. The three slaves can be connected directly to the master or other slaves via the provided paralleling interfaces X2 and X3. The X2 and X3 interfaces are fully identical.

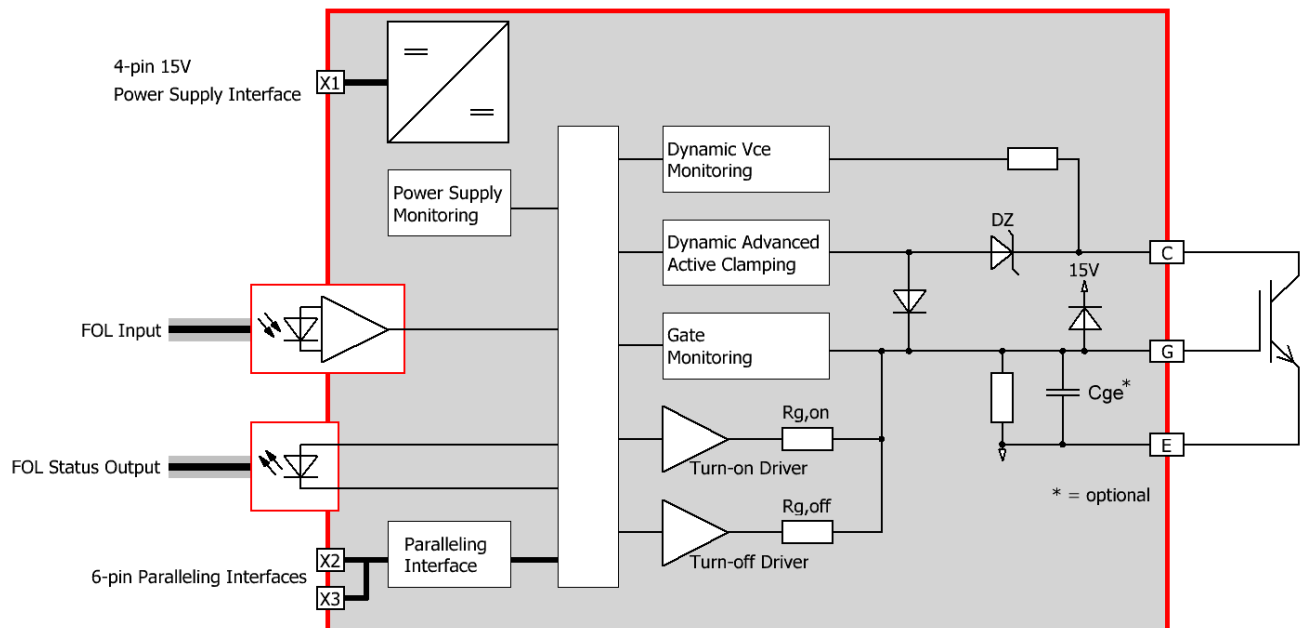

Fig. 2 Basic schematic of the 1SP0635V and 1SP0635S drivers

The driver is equipped with the following features:

- DC/DC converter designed for IGBT modules of the voltage class up to 3300V
- Power supply monitoring
- Fiber-optic interface (drive input and fault feedback)
- Dynamic V_{ce} monitoring (short-circuit protection)

Preliminary Description and Application Manual

- Dynamic Advanced Active Clamping DA²C (overvoltage protection at turn-off)
- Gate monitoring
- Paralleling interfaces X2 and X3 for the master-slave connection

All the components required for the optimal and safe driving of the relevant IGBT module such as smallest gate resistors designed to minimize switching losses, gate clamping, etc. are included on the driver. Moreover, it includes components for setting the monitoring turn-off trip level and the response time. Its plug-and-play capability means that it is ready to operate immediately after mounting. The user needs invest no effort in designing or adjusting the driver to a specific application.

The values for the gate resistors and other key components can be found in the specific data sheets for a given IGBT module /3/.

2. 1SP0635D (Slave)

The basic topology of the 1SP0635D drivers is shown in Fig. 3. 1SP0635D drivers can only be used in conjunction with 1SP0635V or 1SP0635S drivers when parallel connection of IGBT modules is required. 1SP0635D drivers can be connected via the paralleling interface X2 or X3 to a 1SP0635V or 1SP0635S master or to another 1SP0635D slave. Up to three slaves (and a master) can be directly connected in parallel.

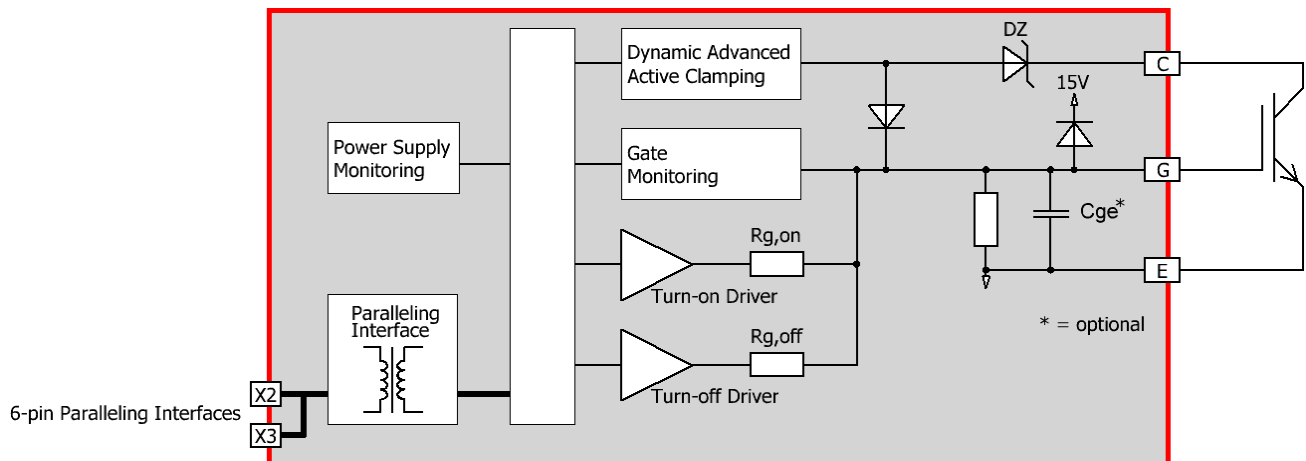

Fig. 3 Basic schematic of the 1SP0635D drivers

The driver is equipped with the following features:

- Power supply monitoring
- Dynamic Advanced Active Clamping DA²C (overvoltage protection at turn-off)
- Gate monitoring
- Paralleling interfaces X2 and X3 for the master-slave or slave-slave connection

All the components required for the optimal and safe driving of the relevant IGBT module such as smallest gate resistors designed to minimize switching losses, gate clamping, etc. are included on the driver.

The supply voltage as well as the input signal are delivered from the master via the paralleling interfaces X2 or X3. No DC/DC converter or fiber optics are present on the 1SP0635D driver. Moreover, no desaturation protection is implemented on the slave, as it is already realized on the master.

Its plug-and-play capability means that it is ready to operate immediately after mounting. The user needs invest no effort in designing or adjusting the driver to a specific application.

Preliminary Description and Application Manual

The values for the gate resistors and other key components can be found in the specific data sheets for a given IGBT module /3/.

3. Parallel connection of IGBT modules with master and slave(s)

If parallel connection of two to four IGBT modules is required, one master as well as one to three slaves must be used. The basic principle is illustrated in Fig. 4.

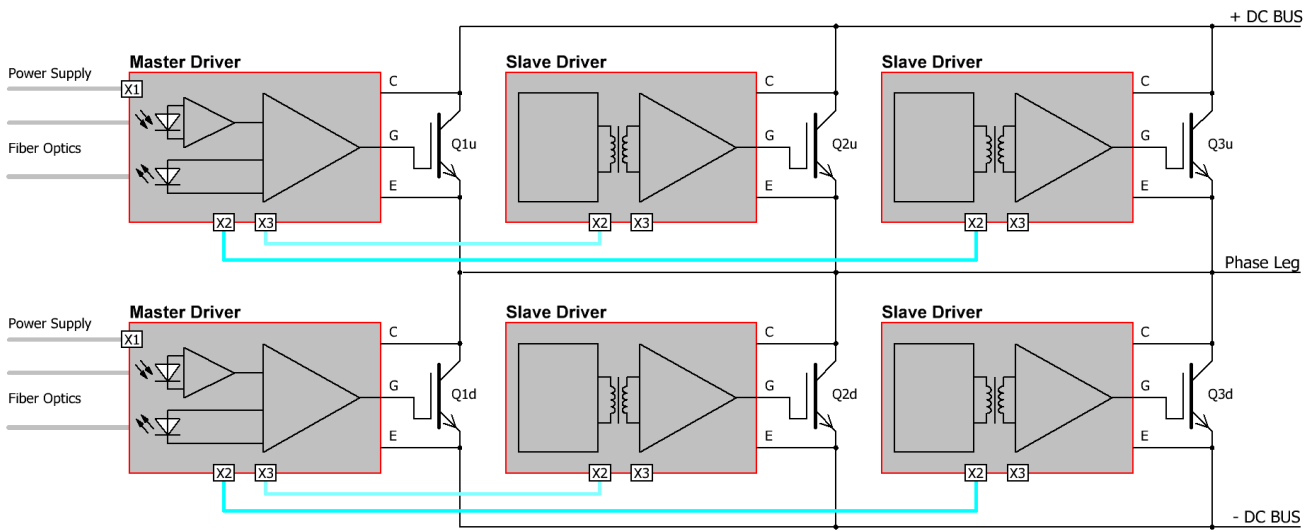

Fig. 4 Principle of parallel connection of 1SP0635 drivers with one master and two slaves in a half-bridge configuration (example)

The electrical isolation is realized on the master (DC/DC converter with transformer for the power supply as well as fiber-optic interface for the input signal and the status feedback). The power supply of the slave as well as the input signal and gate monitoring feedback are transmitted to/from the slave and from/to the master via the interface bus connected to the paralleling interfaces X2 and/or X3 respectively. Both interfaces X2 and X3 are fully identical and interchangeable on the master as well as on the slave. The paralleling interface X2 or X3 makes sure that all paralleled drivers switch on and off synchronously.

The Five Steps to Success

The following steps point out the easy way to use 1SP0635 drivers in power converters:

1. Choose a suitable driver

When applying 1SP0635 drivers, you should note that they are specifically adapted to a particular type of IGBT module.

The type designation of the driver consequently also includes a number corresponding to a specific IGBT module (see "Ordering Information").

If no parallel connection of IGBT modules is required, only one 1SP0635V or 1SP0635S master is to be used. If parallel connection is required, one master as well as one to three slaves are to be used.

These drivers are not valid for IGBT modules other than those specified. Incorrect use may result in failure.

Preliminary Description and Application Manual

2. Attach the drivers to the IGBT modules (one driver per IGBT module)



Any handling of IGBT modules or drivers is subject to the general specifications for protecting electrostatic-sensitive devices according to international standard IEC 60747-1, Chapter IX or European standard EN 100015 (i.e. the workplace, tools, etc. must comply with these standards).

If these specifications are ignored, both IGBTs and drivers may be damaged.

The driver can be easily mounted onto an IGBT module by screwing the corresponding terminals.

3. Connect the driver to the control electronics

Master: Connect the power supply plug X1 as well as the fiber-optic transmitters and receivers. If parallel connection is required, the paralleling interfaces X2 and/or X3 must be connected to the slave(s).

Slave(s): Connect the paralleling interfaces X2 or X3 to the master or another slave. One master must be used in conjunction with the slave(s).

4. Check the driver function

Check the gate voltage of all drivers (master and slaves): For the off-state, the nominal gate voltage is specified in the relevant data sheet /3/. For the on-state, it is +15V. Also check the input current consumption of the driver without clock signals and at the desired switching frequency.

These tests should be performed before installation, as the gate terminals may otherwise not be accessible.

5. Set up and test the power stack

Before starting up the system, it is recommended that each logical switch (parallel connection of IGBT modules) be checked separately under power-cycling conditions. It is usually sufficient to apply the single or double-pulse technique. CONCEPT specially recommends users to check that the IGBT modules switch inside the SOA in the worst case condition. In case of parallel connection of IGBT modules it is also recommended to check the current sharing. These parameters strongly depend on the specific converter construction.

Even if only single IGBTs are tested, all the system's gate drivers must be supplied with energy. All the other IGBTs are then kept in the off state by applying negative gate voltages. This is particularly important when switching the IGBTs under test.

The short-circuit behavior can also be verified at this point.

The system is then ready to start under real-world load conditions. This allows the thermal behavior of the whole arrangement to be determined.

The system must be re-qualified over the entire specified range of temperature and load conditions.



CAUTION: All handling with high voltages involves risk to life.

It is imperative to comply with the respective safety regulations!

Preliminary Description and Application Manual

Mechanical Dimensions

1. 1SP0635V (Master)

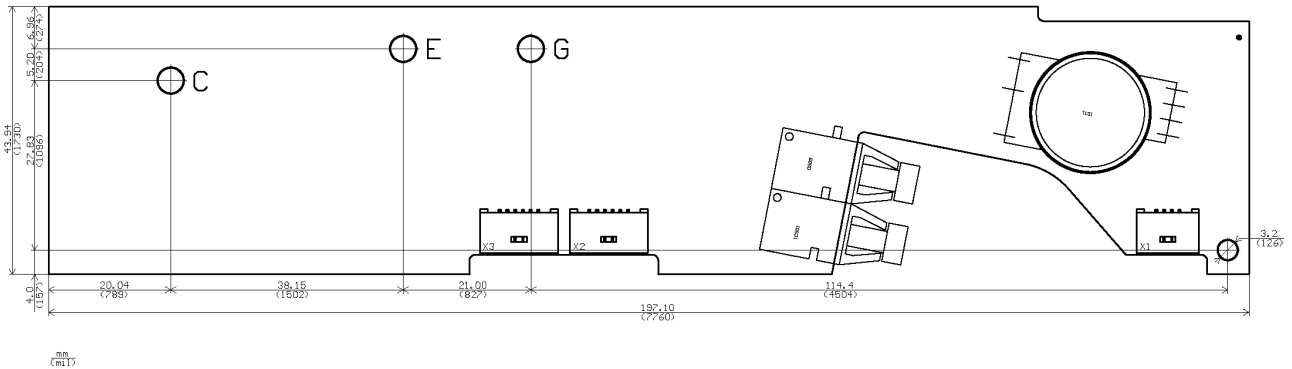

Maximum driver height: 12mm measured from the bottom layer

Fig. 5 Mechanical dimensions of 1SP0635V

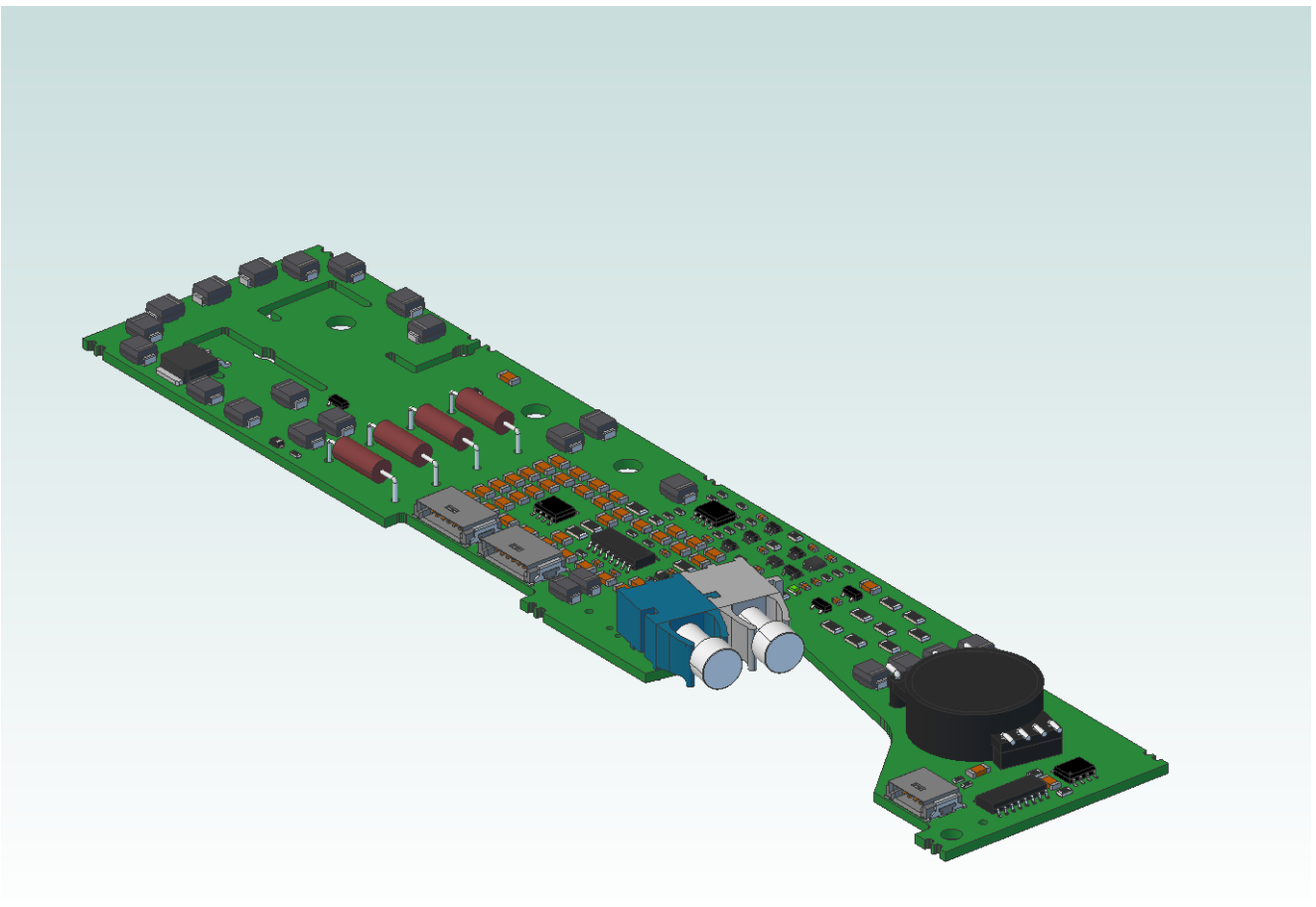
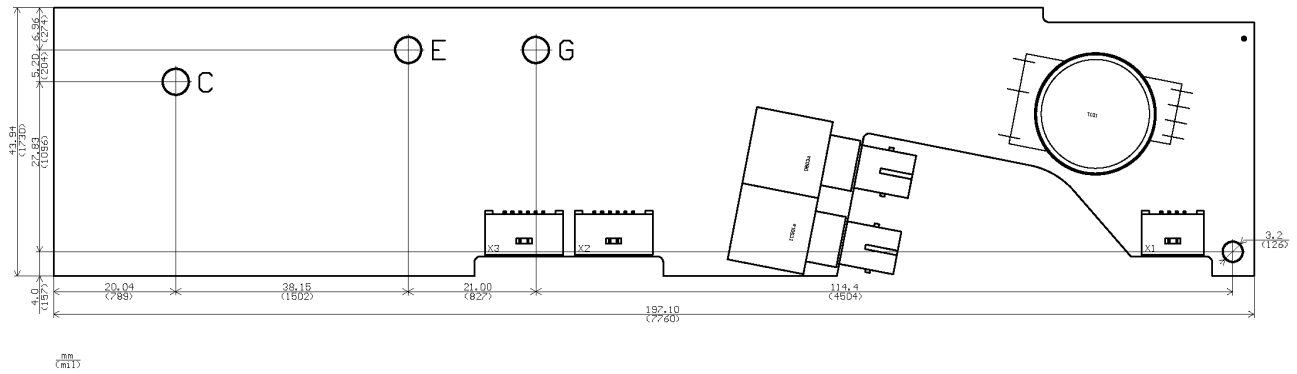

Fig. 6 Interactive 3D drawing of 1SP0635V

Preliminary Description and Application Manual

2. 1SP0635S (Master)



Maximum driver height: 13mm measured from the bottom layer

Fig. 7 Mechanical dimensions of 1SP0635S

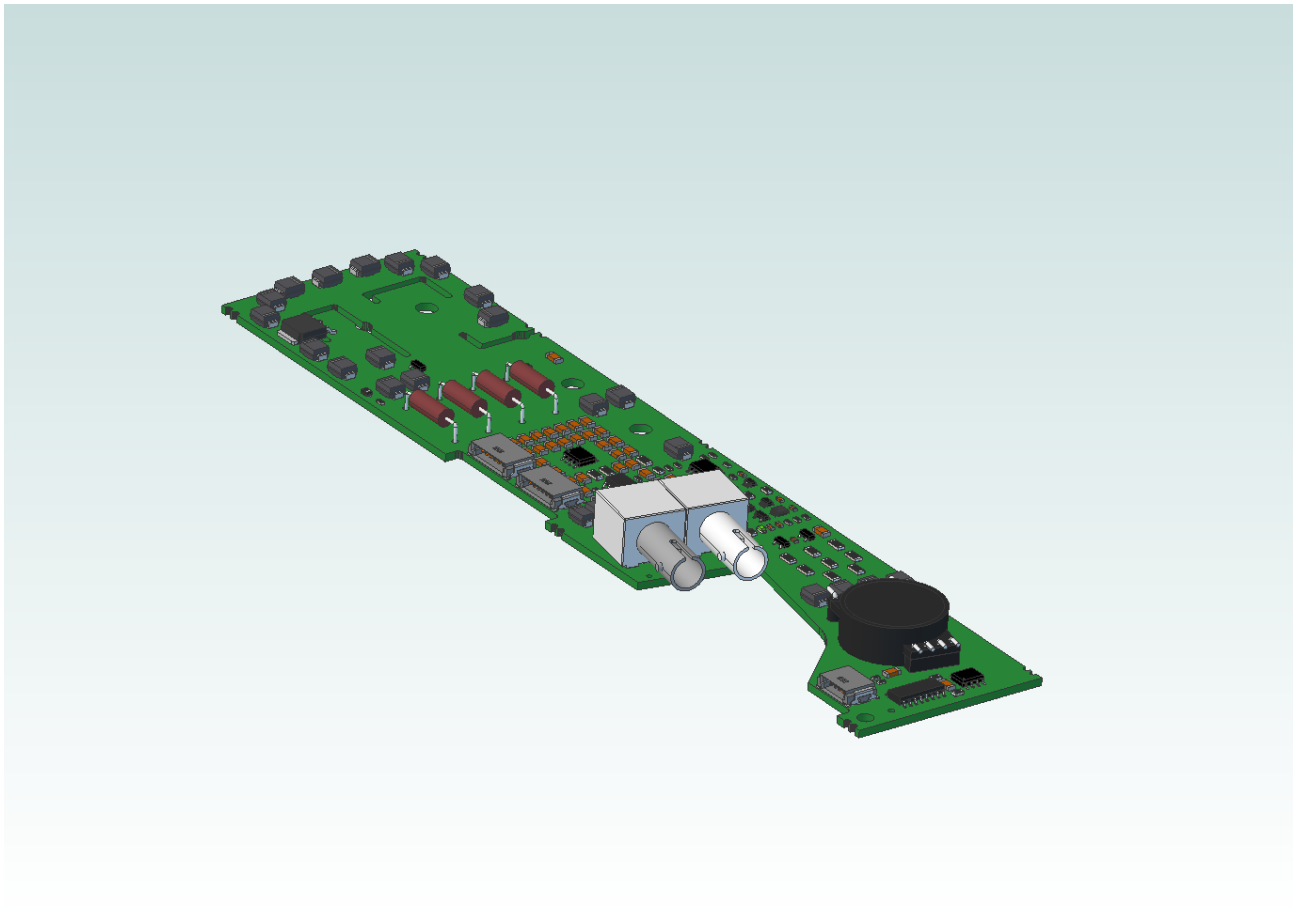
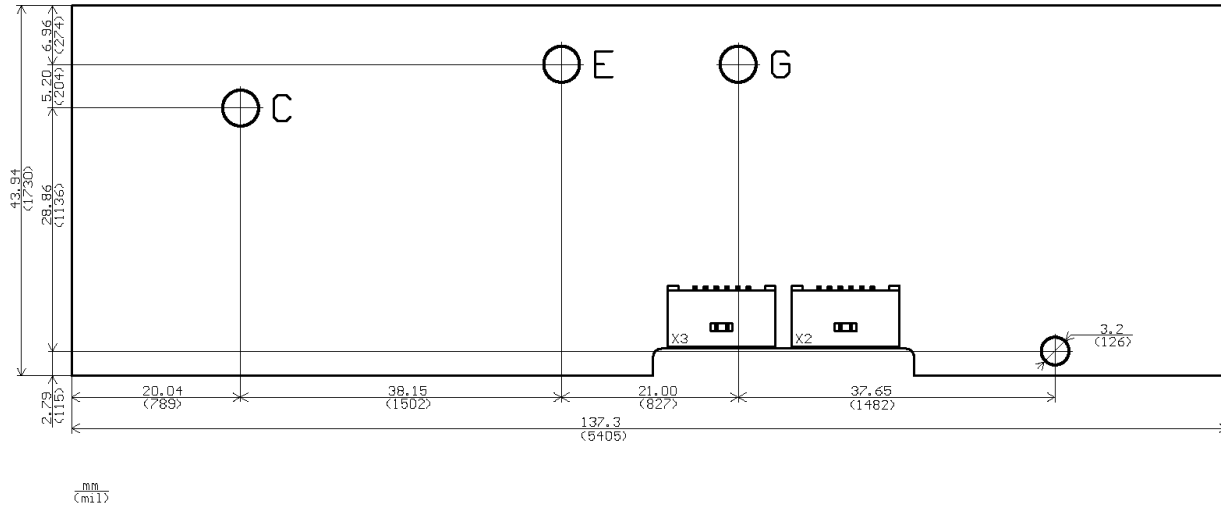

Fig. 8 Interactive 3D drawing of 1SP0635S

Preliminary Description and Application Manual

3. 1SP0635D (Slave)



Maximum driver height: 6mm measured from the bottom layer

Fig. 9 Mechanical dimensions of 1SP0635D

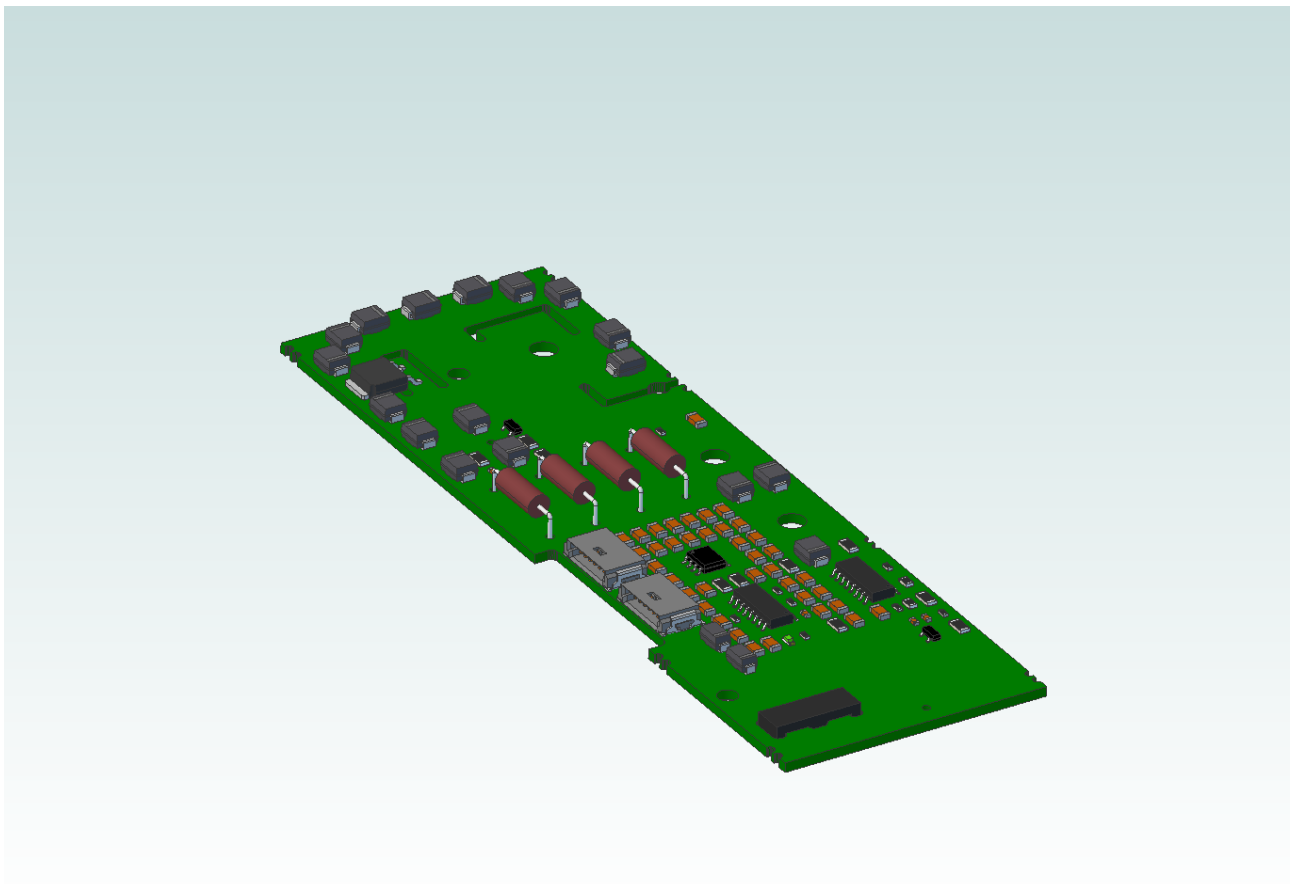



Fig. 10 Interactive 3D drawing of 1SP0635D

Preliminary Description and Application Manual

Recommended Cables and PCB Connectors

The following cables and PCB connectors for the interfaces X1 and X2/X3 are recommended and can be ordered from CONCEPT or from ERNI according to the following table. See also Fig. 11 for more details about the cable arrangement:

Accessories	Interface	Length/ Type	CONCEPT Ordering Number	ERNI Ordering Number	Picture
Cable (Power Supply, 4-pin)	X1	35cm	MBC41-035-0	IDCCS_SRC_1.27_04_SPX_SPX_350_HT	
	X1	45cm	MBC41-045-0	IDCCS_SRC_1.27_04_SPX_SPX_450_HT	
	X1	70cm	MBC41-070-0	IDCCS_SRC_1.27_04_SPX_SPX_700_HT	
	X1	110cm	MBC41-110-0	IDCCS_SRC_1.27_04_SPX_SPX_1100_HT	
Cable (Paralleling, Master to Slave, 6-pin)	X2/X3	30cm	MBC61-030-0	IDCCS_SRC_1.27_06_SPX_SPX_300_HT	
	X2/X3	50cm	MBC61-050-0	IDCCS_SRC_1.27_06_SPX_SPX_500_HT	
	X2/X3	70cm	MBC61-070-0	IDCCS_SRC_1.27_06_SPX_SPX_700_HT	
	X2/X3	110cm	MBC61-110-0	IDCCS_SRC_1.27_06_SPX_SPX_1100_HT	
PCB connector (4-pin)	X1	Right angle	MBCON-4-1-0	214012	See Fig. 12
	X1	Vertical	MBCON-4-2-0	284697	

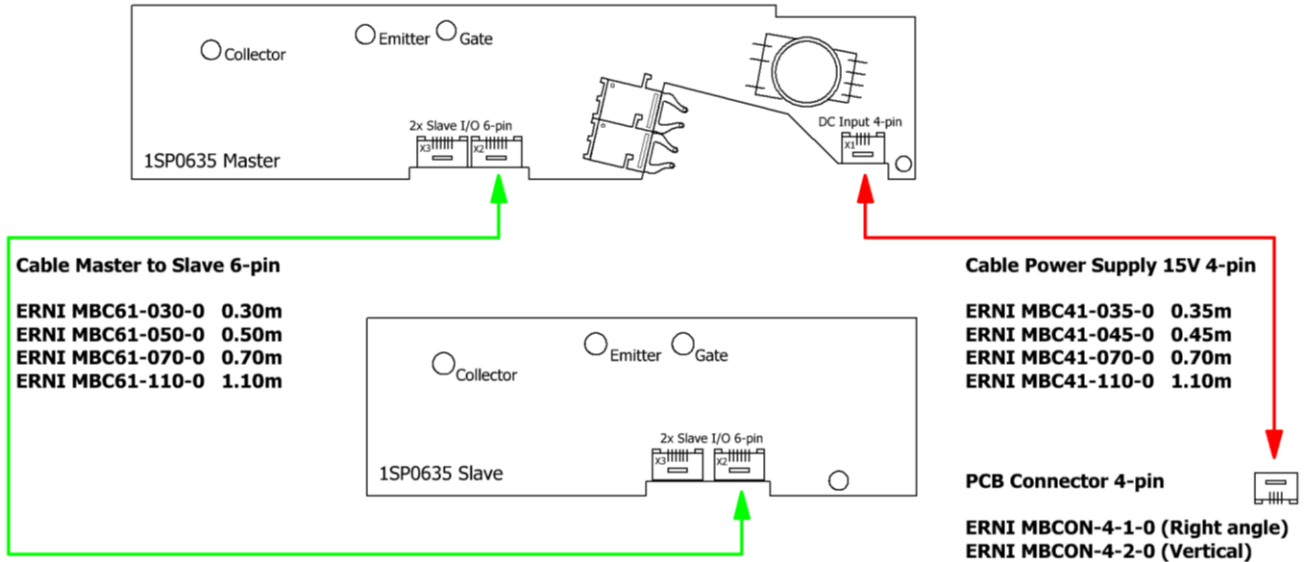

Fig. 11 Cable arrangement for 1SP0635 (Master only or Master and Slave)

All cables are delivered with straight plugs on both sides.

The PCB connectors can be ordered as "right angle" types (the cable is plugged in parallel to the PCB) or as "vertical" types (the cable is plugged vertically to the PCB) according to Fig. 12.

Preliminary Description and Application Manual

Right angle male connector



Vertical male connector



Fig. 12 Right angle male and vertical male connectors

Refer to www.igbt-driver.com/go/ext_erni for more information.

Please note that the paralleling cables carry high potential. The voltage rating of the recommended cables is only 300V. They must therefore be isolated. The user is fully responsible to apply sufficient isolation to the delivered cables.

Pin Designation of Connector X1 (Power Supply of 1SP0635V/1SP0635S)

Pin	Des.	Function	Pin	Des.	Function
1	GND	Ground	2	VDC	+15V for DC/DC converter
3	VDC	+15V for DC/DC converter	4	GND	Ground

Description of Interface X1 (Power Supply of 1SP0635V/1SP0635S)

The driver is equipped with a 4-pin interface connector to supply the DC-DC converter for the driver secondary side. It is recommended to connect both GND as well as both VDC pins. For recommended cables, please read the paragraph "Recommended Cables and PCB Connectors" on Page 11.

The driver limits the inrush current at startup, and no external current limitation of the voltage source for VDC is needed.

Description of the Fiber-Optic Input (1SP0635V/1SP0635S)

This is the drive input.

Description of the Fiber-Optic Output (1SP0635V/1SP0635S)

During normal operation (i.e. the driver is supplied with power at nominal voltage, and there is no fault anywhere), the status feedback is given by a "light on" at the optical link. A malfunction is signaled by a "light off".

Each edge of the control signal is acknowledged by the driver with a short pulse (the light is off for a period of about 700ns). Because this can be observed by the host controller, this method allows simple and continuous monitoring of all drivers and fiber-optic links of the system. Fig. 13 shows the control and response signals of a gate driver in normal operation.

Preliminary Description and Application Manual

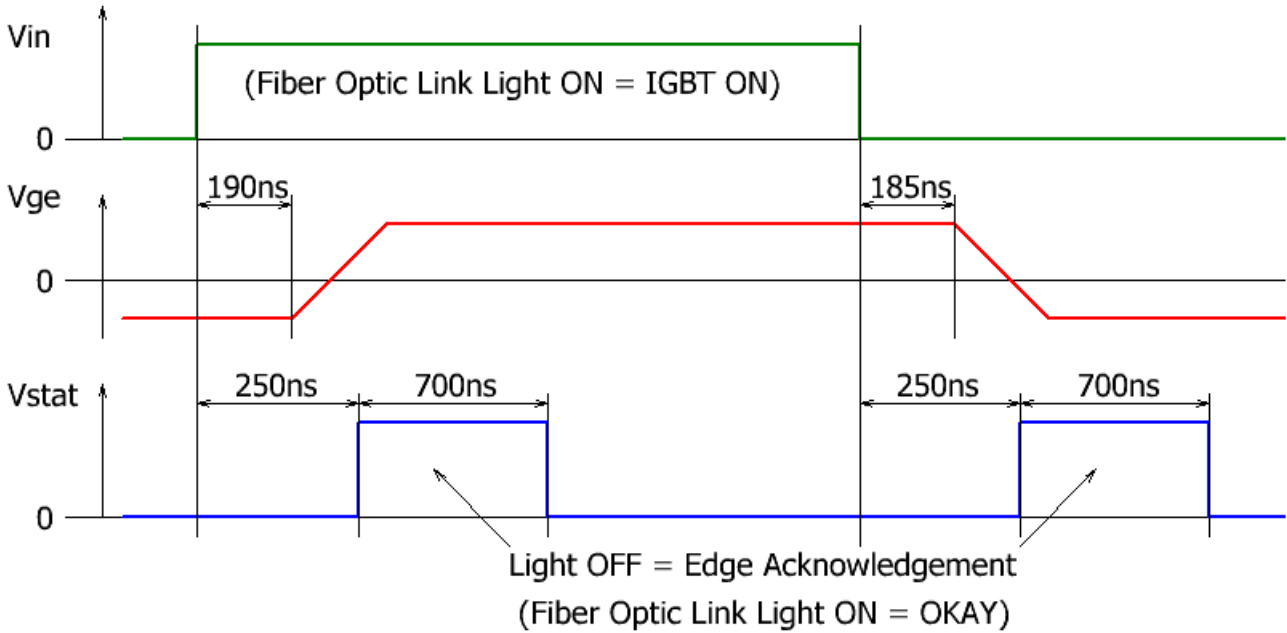

Fig. 13 Driver behavior and status feedback in normal operation

Fig. 14 shows the response of the driver in the event of a short-circuit fault. The fault status is transferred to the status feedback terminal after the response time. The light is then driven "off" during the delay to clear the fault state (about 9µs). The driver shuts the IGBT off about 0.3µs after the response time. The IGBT can be turned on again by applying a positive edge to the corresponding fiber-optic input after the fault status has disappeared.

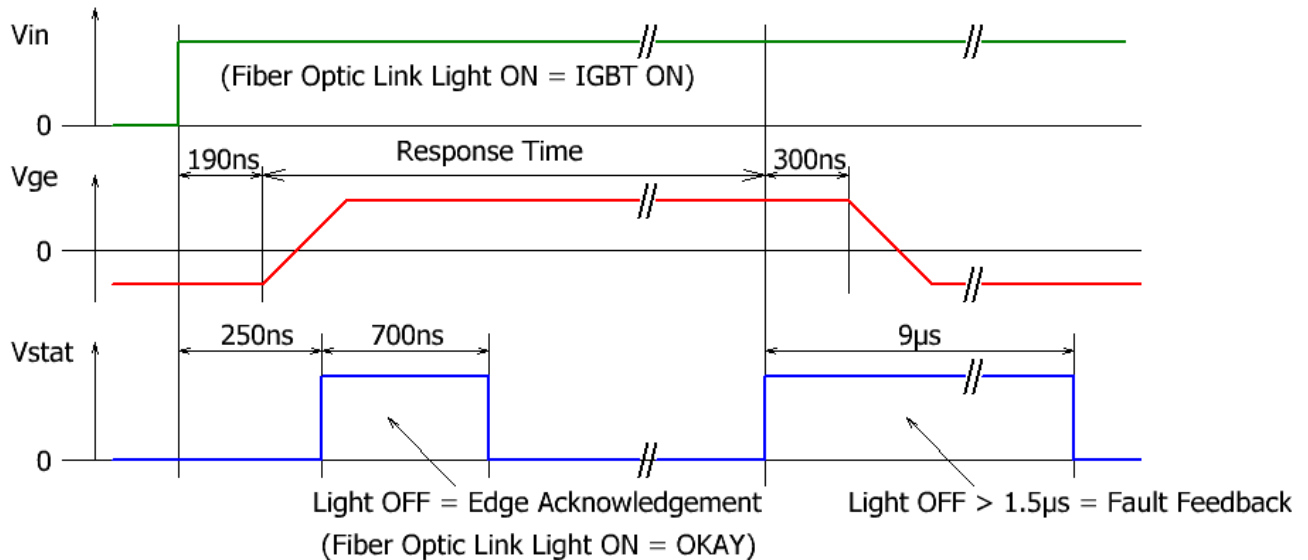

Fig. 14 Driver behavior and status feedback in the short-circuit condition

In the event of a gate monitoring fault, the fault status is transferred to the status feedback terminal after the filter delay (refer to the relevant data sheet /3/ for timing information) and remains active as long as the gate-monitoring fault is present.

If the driver goes from the "off state" to the "on state", and the gate-emitter voltage of one or more parallel connected drivers does not turn on, the driver response (V_{ge2} does not switch) is shown in Fig. 15. The fault status is transferred to the status feedback terminal after the filter delay. The driver shuts the IGBT off about

Preliminary Description and Application Manual

0.3μs after the filter delay, and thus clears the fault condition. The light is driven "off" during about 1μs (0.3μs plus the acknowledge pulse width of 0.7μs).

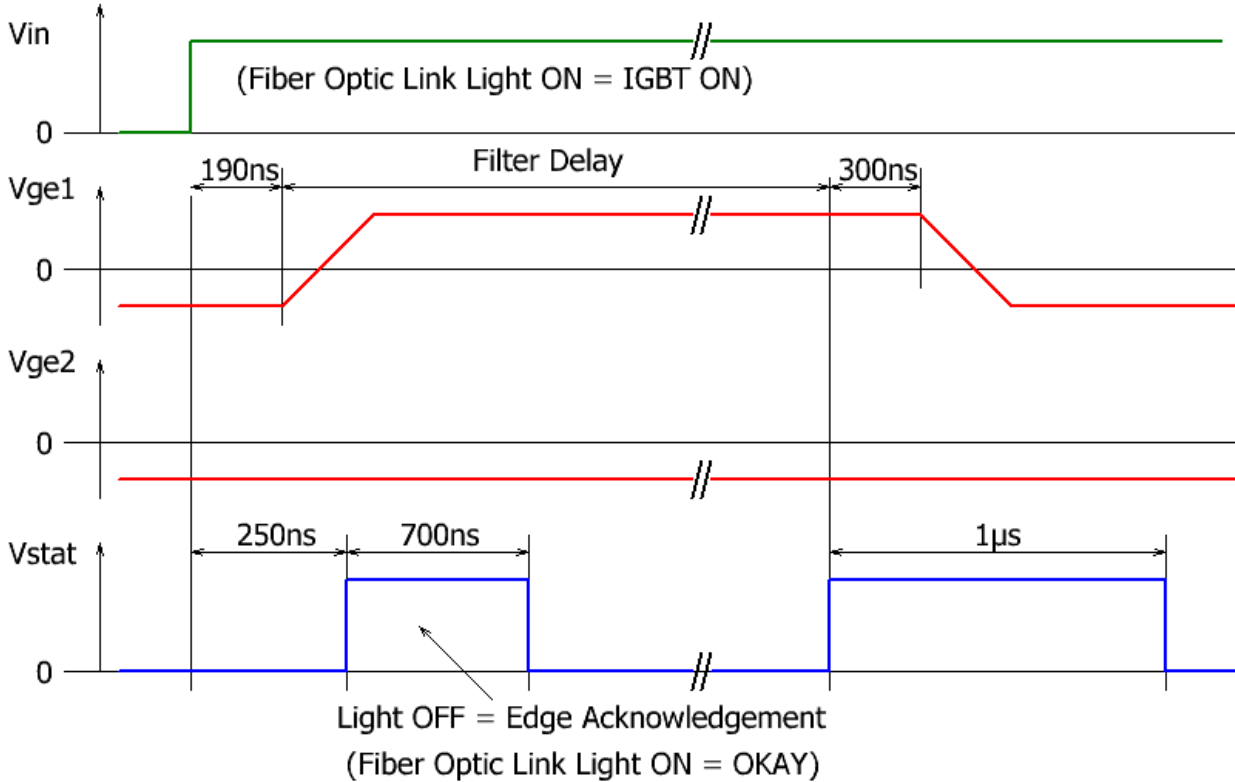

Fig. 15 Driver behavior and status feedback in the event of a gate-monitoring fault at turn-on

If the driver goes from the "on state" to the "off state", and the gate-emitter voltage of one or more parallel connected drivers does not turn off, the fault is applied to the status feedback terminal as long as it is present. In case of a secondary supply undervoltage fault on the master driver, the fault status remains active and the driver is locked as long as this undervoltage remains. The driver response in the event of a supply undervoltage on Viso-Vee is shown in Fig. 16.

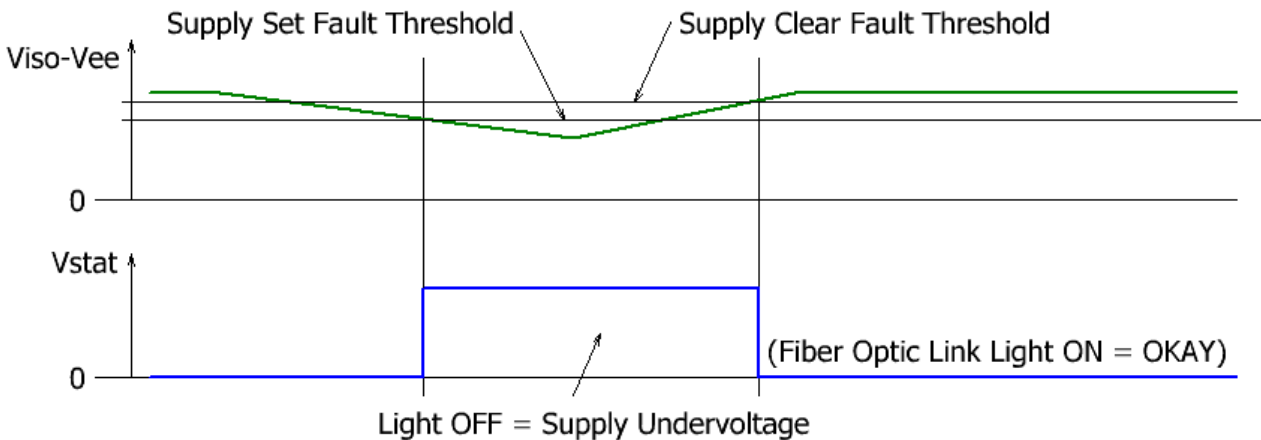

Fig. 16 Status feedback in the event of a supply undervoltage of the master driver

N.B. During power up, the status feedback will also show a fault condition until the supply undervoltage disappears.

Preliminary Description and Application Manual

Recommended Interface Circuitry for Fiber Optics (1SP0635V/1SP0635S)

The fiber-optic links are available in two versions (refer to the relevant data sheet /3/): "Versatile" fiber-optic link (1SP0635V) and "ST" fiber-optic link (1SP0635S). See also Fig. 5 and Fig. 7.

The recommended circuitry for the fiber-optic links is given in Fig. 17 (1SP0635V) and Fig. 18 (1SP0635S).

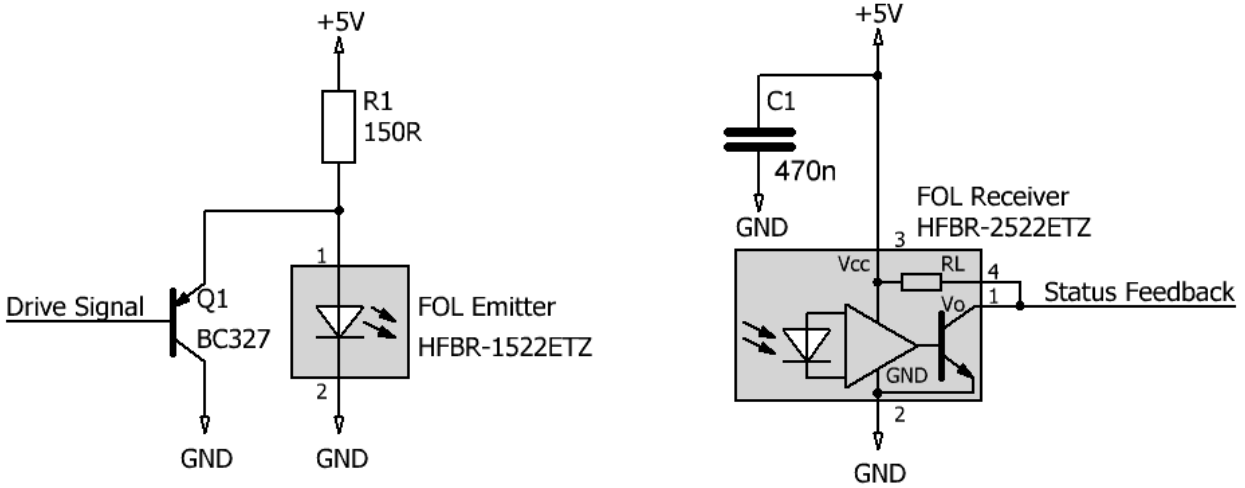

Fig. 17 Recommended circuitry for the "versatile" fiber-optic links (1SP0635V)

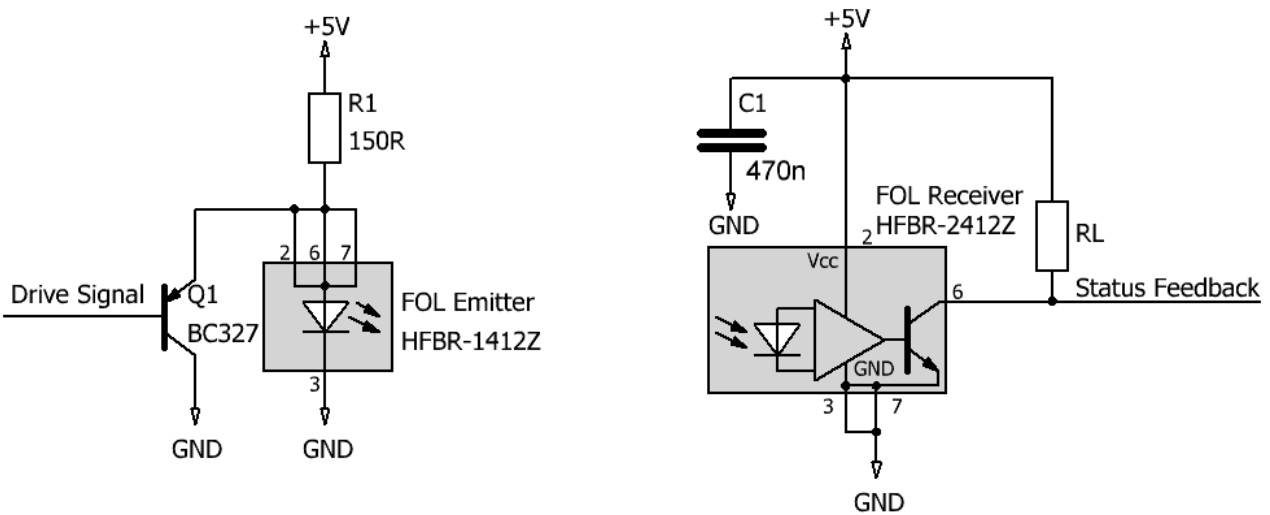

Fig. 18 Recommended circuitry for the "ST" fiber-optic links (1SP0635S)

Preliminary Description and Application Manual

Description of Paralleling Interfaces X2 and X3

The paralleling interfaces X2 and X3 are available on the 1SP0635V/1SP0635S (master) as well as on the 1SP0635D (slave). They allow the following to be connected:

- A master to one or two slaves
- A slave to the master or to another slave

Both connectors X2 and X3 are connected in parallel. The following signals are available on this interface:

- Supply voltage from the master to the slaves
- Drive signal from the master to the slaves. The drivers are configured so that all paralleled IGBT modules switch on and off synchronously.
- Gate-monitoring signal from the slaves to the master

For recommended cables, please read the paragraph "Recommended Cables and PCB Connectors" on Page 11.

The immunity of the paralleling interface against a high rate of change of magnetic fields (inductive coupling) and electrical fields (capacitive coupling) has been extensively tested in the laboratory. Even in harsh field environments it was not possible to disturb the driver function using the recommended paralleling cables. It is however recommended to place the paralleling cables in locations with low magnetic and electrical field coupling. Note that the immunity against inductive coupling can be increased by using a flat ribbon cable with twisted cable pairs and/or by shielding the cables.

Please note that the paralleling cables carry high potential. The voltage rating of the recommended cables is only 300V. They must therefore be isolated in an adequate way.

LED-Status Indicators

To facilitate verification, master and slave drivers are each equipped with a green status LED. These are located close to the fiber-optic links (master) and to the paralleling interface X2 (slave) respectively and light up under normal operation. A turned-off LED means that the respective driver is not supplied with voltage, the supply voltage is too low (master and slave) or that the gate monitoring function has detected a fault condition (master). Moreover, in case of IGBT short-circuit, the LED on the master is switched off during the delay to clear the fault state (see data sheet /3/ for timing information).

How Do 1SP0635V and 1SP0635S SCALE-2 Drivers Work in Detail (Masters)?

Overview

The 1SP0635V and 1SP0635S series of plug-and-play single-channel drivers are designed for high-power and high-voltage IGBT modules. 1SP0635V and 1SP0635S SCALE-2 drivers are equipped with the usual protection functions such as dynamic V_{ce} monitoring for short-circuit protection, supply-undervoltage shutdown and status feedback. A gate monitoring function is also implemented on 1SP0635V and 1SP0635S drivers. Moreover, a paralleling interface allows the parallel connection up to four IGBT modules using 1SP0635D slave drivers (see also Fig. 4).

Outstanding features of 1SP0635V and 1SP0635S SCALE-2 drivers are: compact size, simple mounting - directly onto the IGBT module, the dynamic advanced active-clamping function DA²C and a very low

Preliminary Description and Application Manual

propagation delay time. Active clamping describes an active scheme designed to protect the IGBTs against overvoltage during turn-off. It is particularly relevant when turning an IGBT off in cases of high DC-link voltage and collector current or short circuit.

Power supply and electrical isolation

The driver is equipped with a DC/DC converter to provide an electrically insulated power supply to the gate driver circuitry. SCALE-2 plug-and-play drivers are designed for the same insulation and test voltages as the corresponding IGBT module (refer to the data sheets /3/).

Note that the driver needs a stabilized supply voltage.

Clearance and creepage distances are designed according to IEC 60077-1.

Power-supply monitoring

The driver's secondary side is equipped with a local undervoltage monitoring circuit.

In case of secondary-side supply undervoltage, the IGBT (as well as all paralleled IGBTs if parallel-connected IGBTs are used) is driven with a negative gate voltage to keep it in the off-state (the driver is blocked) and a fault condition is transmitted to the fiber-optic status feedback.

Even in the case of a low power supply voltage, the driver provides a low-impedance path from the IGBT gate to the emitter.

Within a half-bridge, it is advised not to operate the IGBTs with an IGBT driver in the event of a low supply voltage. Otherwise, a high rate of increase of V_{ce} may cause partial turn-on of these IGBTs.

Preliminary Description and Application Manual

V_{ce} monitoring / short-circuit protection

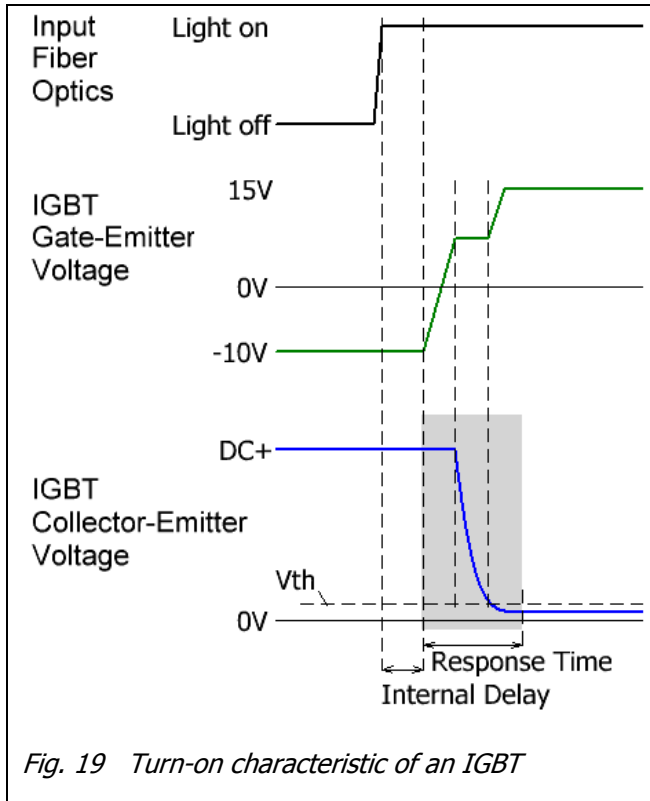

A dynamic V_{ce} monitoring circuit is implemented in 1SP0635V and 1SP0635S gate drivers. The IGBT collector-emitter voltage is measured with a resistor network.

V_{ce} is checked after the response time (see Fig. 14) at turn-on to detect a short circuit. If this voltage is higher than the programmed threshold V_{th} , the driver detects a short circuit at the IGBT and signals it immediately to the fiber-optic status feedback. After an additional delay, the corresponding IGBT is switched off. The fault feedback is automatically reset after the delay to clear the fault state. The IGBT is turned on again as soon as the next positive edge is applied to the fiber-optic input after the fault status has disappeared.

The dynamic V_{ce} monitoring circuit allows the V_{ce} curve form to be given a better fit.

It should be noted that the response time is dependent on the DC-link voltage. It remains constant between about 50% to 100% of the maximum DC-link voltage and increases at lower DC-link voltages. Please read the relevant driver

data sheet for timing information [3/].

Note: The desaturation function is for short-circuit detection only and cannot provide overcurrent protection. However, overcurrent detection has a lower time priority and can be easily provided by the application.

Gate monitoring

The driver is equipped with a gate monitoring function. The mean value $V_{GE,mean}$ of all gate voltages (master and all slaves) is filtered and compared to reference values at turn-on and turn-off (refer to the corresponding data sheet for the values [3/]). If the specified values are exceeded ($V_{GE,mean} < V_{GE,on,min}$ at turn-on resp. $V_{GE,mean} > V_{GE,off,max}$ at turn-off), the driver turns off all parallel-connected IGBTs and a fault is transmitted to the status output.

The gate monitoring function allows converter operation to be avoided if one or more paralleled drivers are not switching according to the reference value (drive signal input).

Note that the gate monitoring function does not apply to slaves not connected to the master over the paralleling interface. In this case, the corresponding slave will not switch, but no gate monitoring fault will be generated.

Preliminary Description and Application Manual

How Do 1SP0635D Drivers Work in Detail (Slaves)?

Overview

The 1SP0635D series of plug-and-play single-channel drivers (slaves) are designed for high-power and high-voltage IGBT modules. They can only be used in conjunction with 1SP0635V or 1SP0635S SCALE-2 drivers (masters) when parallel connection of IGBT modules is required. A paralleling interface allows connection of the 1SP0635D slaves with the 1SP0635V or 1SP0635S master driver (see also Fig. 3).

The drivers are equipped with protection functions such as supply undervoltage shutdown and the gate monitoring function. No V_{CE} monitoring is implemented on 1SP0635D drivers, as this function is already realized on the master driver.

Outstanding features of 1SP0635D drivers are: compact size, simple mounting - directly onto the IGBT module, the dynamic advanced active-clamping function DA²C and a very low propagation delay time. The slave drivers are fully synchronized with the master driver thanks to the paralleling interface. Moreover they do not need a separate power supply as this is delivered via the paralleling interface.

Power supply and electrical isolation

The power supply of 1SP0635D is delivered from the master driver via the paralleling interfaces X2 or X3. The insulation is provided on the master driver, so no isolation has to be provided on the slaves.

However, an insulation of $200V_{peak}$ is provided on the slave drivers. This allows dynamic voltage differences between parallel-connected drivers to be withstood in case the switching operation is not fully symmetrical.

The signal insulation is realized with a planar transformer.

Coreless common mode coils are placed in the supply conductors in order to limit the dynamic equalizing currents flowing from and to the master during not fully symmetrical switching operation. Please read the corresponding data sheet for allowed maximum values /3/. It is recommended to measure the resulting equalizing current flowing via the paralleling interface.

Note that the peak value as well as the RMS value of the equalizing current can be reduced by inserting a ferrite core via the paralleling cables if required.

Clearance and creepage distances are designed according to IEC 60077-1.

Power-supply monitoring

The slave drivers are equipped with a local undervoltage monitoring circuit.

In case of a supply undervoltage, the corresponding IGBT is driven immediately with a negative gate voltage to keep it in the off-state (the channel is blocked). Only the corresponding IGBT is switched off immediately, and not all paralleled IGBTs. However, all other parallel-connected IGBTs will be turned off by the gate monitoring function implemented on all drivers after the given delay (see corresponding data sheet /3/ for timing information).

In the event of a supply voltage interruption, it cannot be predicted which driver (master or slaves) will detect the supply undervoltage first. In order to avoid asynchronous turn-off of parallel connected IGBT modules in case of a local undervoltage supply voltage detection of a slave driver, the user is advised to implement an additional supply voltage monitoring on the primary supply voltage of the master driver. It is recommended to

Preliminary Description and Application Manual

set the threshold limit at 13V. As soon as the main supply voltage of the master falls below this limit, the master driver must be turned off. All parallel-connected IGBT modules will then be switched off synchronously.

Even in the case of a low power supply voltage, the driver provides a low-impedance path from the IGBT gate to the emitter.

Within a half-bridge, it is advised not to operate the IGBTs with an IGBT driver in the event of a low supply voltage. Otherwise, a high rate of increase of V_{ce} may cause partial turn-on of these IGBTs.

V_{ce} monitoring / short-circuit protection

No V_{ce} monitoring circuit is implemented on the slave drivers, as this function is already realized on the master driver.

Gate monitoring

Refer to the paragraph "Gate monitoring" under "How Do 1SP0635V and 1SP0635S SCALE-2 Drivers Work in Detail (Masters)?" on page 18.

General Considerations using 1SP0635V/1SP0635S/1SP0635D

Parallel connection of IGBT modules using 1SP0635 drivers

When using 1SP0635 drivers to drive parallel connected IGBT modules, it is important – like in every parallel connection of IGBT modules – to ensure their symmetrical operation. Measurements in half-bridge topologies have shown that highly symmetrical operation of the paralleled IGBT modules can be reached when using a properly designed converter. The following points must especially be considered:

- The converter should be constructed as symmetrically as possible with respect to the paralleled IGBT modules in order to ensure symmetrical operation. The DC-link stray inductance of each paralleled IGBT module in particular should be similar ($L_{s1} \approx L_{s2}$, $L_{s5} \approx L_{s6}$ in Fig. 20).
- It is important – except for the load terminals (L_{s5} and L_{s6}) – to have a low-inductance connection between all paralleled IGBT modules. This avoids large difference voltages between these modules.
- Generally speaking, it is advantageous to keep the DC-link stray inductance of the converter low.
- Increasing the output inductances L_{s5} and L_{s6} helps to reduce the dynamic current imbalance during commutation.
- Some power semiconductor manufacturers offer selected IGBT modules for parallel connection. If available, it is strongly recommended to use selected IGBT modules in order to avoid current imbalances during operation.

Preliminary Description and Application Manual

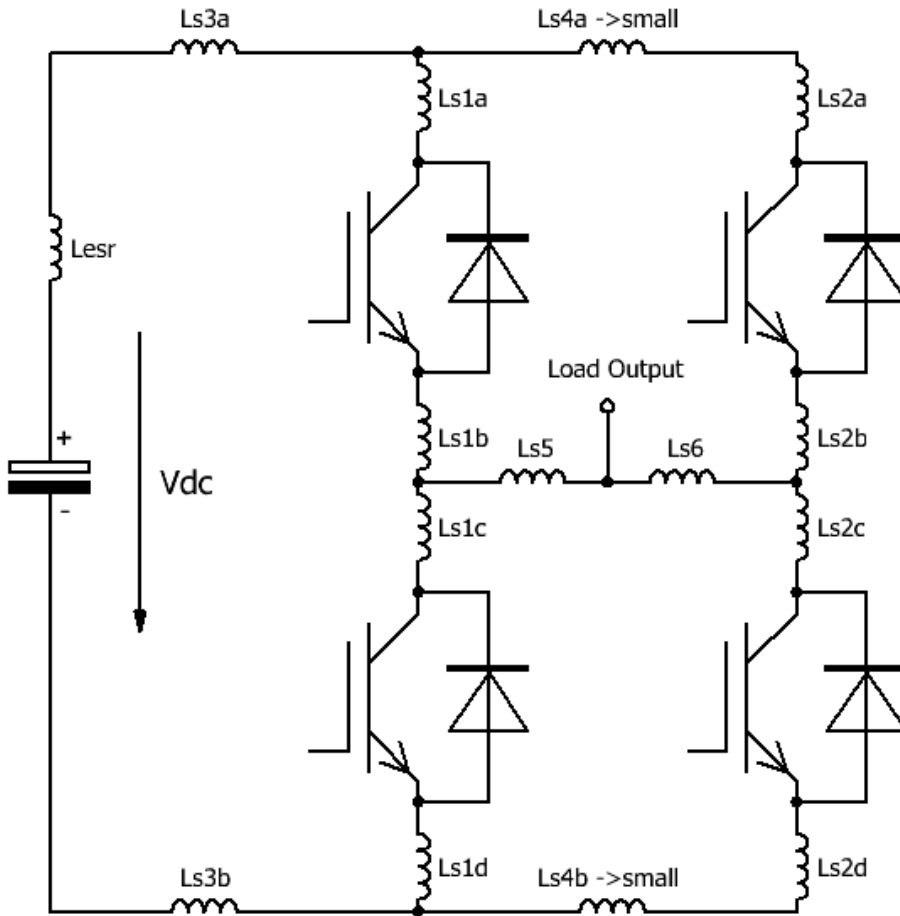

Fig. 20 Half-bridge topology with stray inductances

Fig. 21 shows an exemplary turn-off and turn-on transition (collector voltages and currents) of three 1500A/3300V IGBT modules controlled with 1SP0635 drivers.

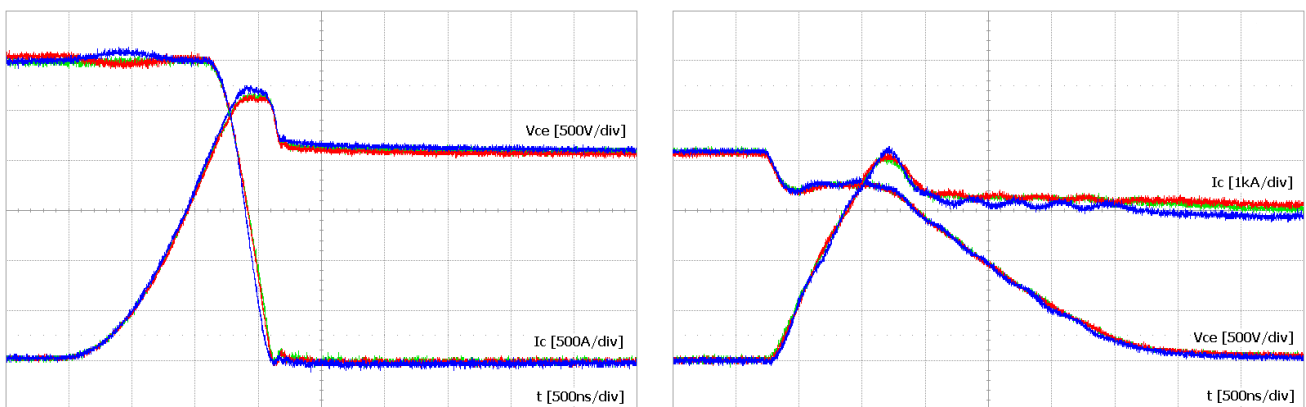

Fig. 21 Turn-off (left) and turn-on (right) behavior of three 1500A/3300V IGBT modules in parallel connection at a DC-link voltage of 2200V and a collector current of 3000A each

Preliminary Description and Application Manual

Dynamic behavior of IGBTs

The dynamic behavior of IGBT modules depends on their type and manufacturer due to the specific behavior of the included IGBT and diode chips, the particular module construction and the distribution of the internal gate resistances and inductances. Note that different module types from the same manufacturer may also require a specific gate-driver adaptation.

CONCEPT therefore supplies specific versions of SCALE-2 plug-and-play drivers adapted to the particular IGBT module. These drivers must not be used with IGBT modules other than those for which they were specified.

Turn-on of the IGBT / commutation of diode current

When a driver input goes high, the gate driver turns on the corresponding IGBT. The driver already includes the gate resistors, which are matched to the relevant IGBT module.

The driver is optimized to achieve minimum switching losses for the case of relatively low inductances within the power stack. It is recommended to check the commutation behavior within the final system assembly.

Turn-off of the IGBT

The IGBT is turned off when the corresponding input turns low. The gate resistors are determined by CONCEPT and must not be altered.

Fast turn-off of the IGBT may cause an overvoltage, which increases with DC-link voltage or load current. The turn-off overvoltage can be approximated by:

$$V_{tr} = -L_s * di_c/dt$$

where V_{tr} is the turn-off overvoltage, i_c the collector current and L_s the stray inductance.

Most competing drivers are unable to limit the overvoltage in case of overload or short circuit. However, this is essential for high-power or high-voltage IGBTs. To solve this problem, SCALE-2 plug-and-play drivers provide a Dynamic Advanced Active Clamping function DA²C which is described below.

Dynamic Advanced Active Clamping DA²C

Active clamping is a technique designed to partially turn on the IGBT in case the collector-emitter voltage exceeds a predefined threshold. The IGBT is then kept in linear operation. The basic circuit for active clamping can be found in /4/.

Basic active-clamping topologies implement a single feedback path from the IGBT's collector through transient voltage suppressor devices (TVS) to the IGBT gate. 1SP0635 SCALE-2 drivers support CONCEPT's Dynamic Advanced Active Clamping (DA²C) based on this principle:

- When active clamping is activated, the turn-off MOSFET of the driver is switched off in order to improve the effectiveness of the active clamping and to reduce the losses in the TVS. This feature – called Advanced Active Clamping – is mainly integrated in the secondary-side ASIC.
 - Additional transient voltage suppressors (TVS) have been added in series to the TVS required to withstand the maximum DC-link voltage under switching operation. These TVS are short-circuited during the IGBT on state as well as during about 15-20us after the turn-off command to guarantee efficient active clamping. After this delay, these additional TVS are activated and allow the DC-link voltage to be increased to a higher value during the IGBT off-state (e.g. after emergency shut-down).
-

Preliminary Description and Application Manual

This feature – together with Advanced Active Clamping – is called Dynamic Advanced Active Clamping DA²C. Note that the time during which the voltage can be applied above the value for switching operation should be limited to short periods (< 60 seconds).

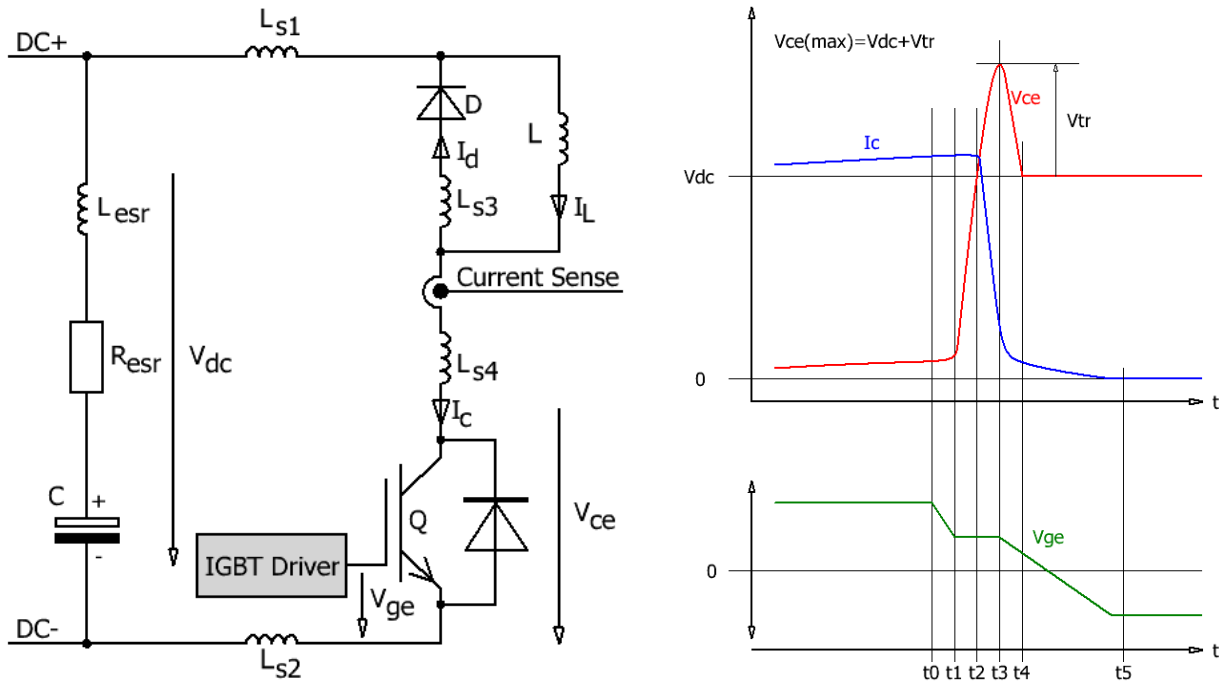

Fig. 22 Test circuit (left) and typical switching behavior (right)

Legend to Fig. 22

- t0 = Initiation of the turn-off process
- t1 = Start of turn-off time
- t2 = Start of collector current fall time
- t3 = Maximum collector to emitter voltage
- t4 = IGBT is blocking, start of tail current
- t5 = End of tail current

In comparison with other driving methods, active clamping allows enhanced utilization of the IGBT modules during normal operation by increasing the switching speed and therefore reducing switching losses. The overvoltage at fault-current turn-off is also managed by active clamping.

The value of the maximum DC-link voltage under switching operation and in IGBT off state can be found in the specific data sheets for a given IGBT module /3/.

Fig. 23 shows an exemplary turn-off transition of a 1500A/3300V IGBT module controlled with a 1SP0635V driver.

Preliminary Description and Application Manual

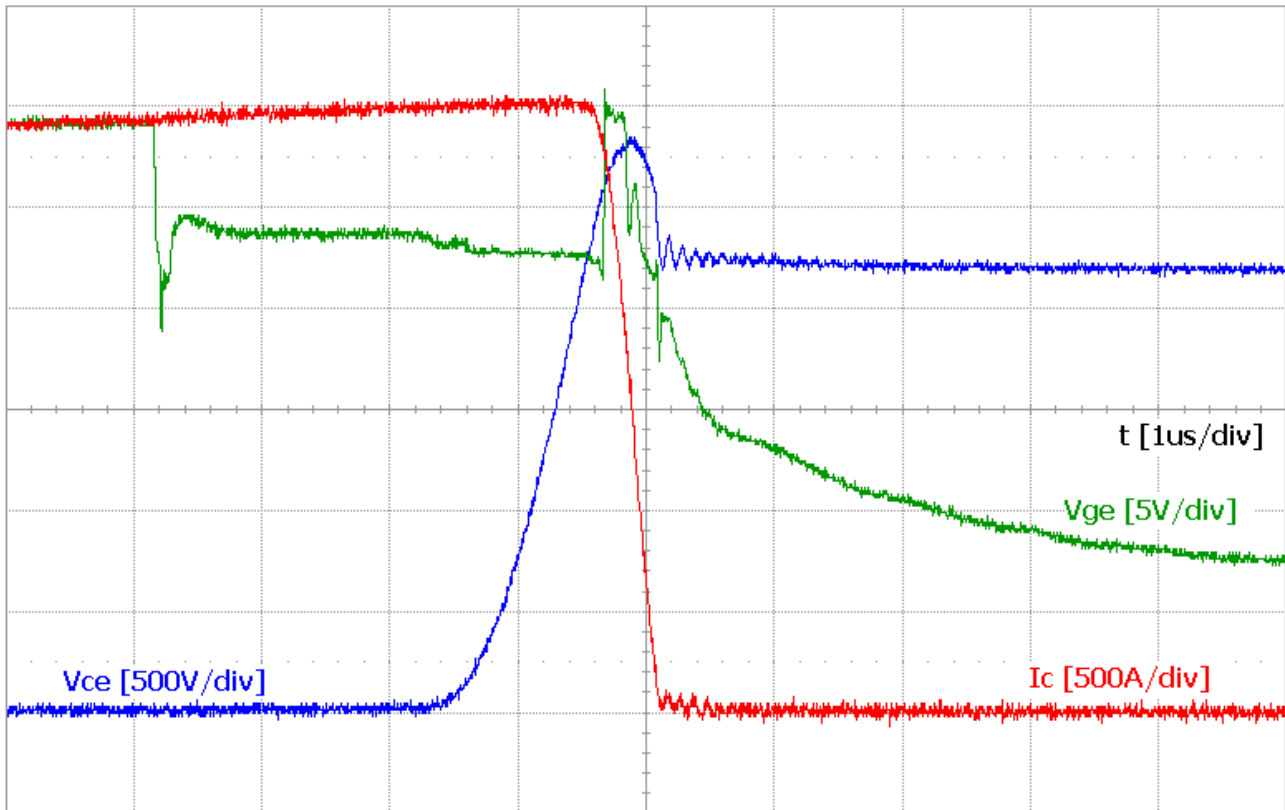

Fig. 23 Behavior of a 1500A/3300V IGBT module turning off at a DC-link voltage of 2200V a collector current of 3000A, which is twice the nominal collector current

Low-inductance layout

The active-clamping function should not lead anyone to forget about the inductances of the power stack. For several reasons, it is still necessary to reduce the DC-link stray inductance to about 25nH...120nH with 1SP0635 plug-and-play drivers.

3-level and multilevel topologies

If 1SP0635 drivers are to be used in 3-level or multilevel topologies, please refer to application note AN-0901 /5/.

Higher requirements for traction applications or similar

The power-supply interface X1 as well as the paralleling interfaces X2 and X3 provide a mechanical interlock and are suitable for traction applications.

The vibration withstand capability of 1SP0635 SCALE-2 drivers can be improved by screw-fitting the driver board onto the cooler (see Fig. 24). **However, it should be noted that these connections must be electrically insulated to comply with the particular clearance and creepage distance requirements (e.g. use of plastic distance bolts).**

Furthermore, an interlocking version of the fiber optic links is available (see Fig. 24) and ST fiber-optic links may also be supplied (1SP0635S). For available fiber-optic links, refer to the data sheets /3/.

Preliminary Description and Application Manual

Note that clearance and creepage distances are designed according to IEC 60077-1.

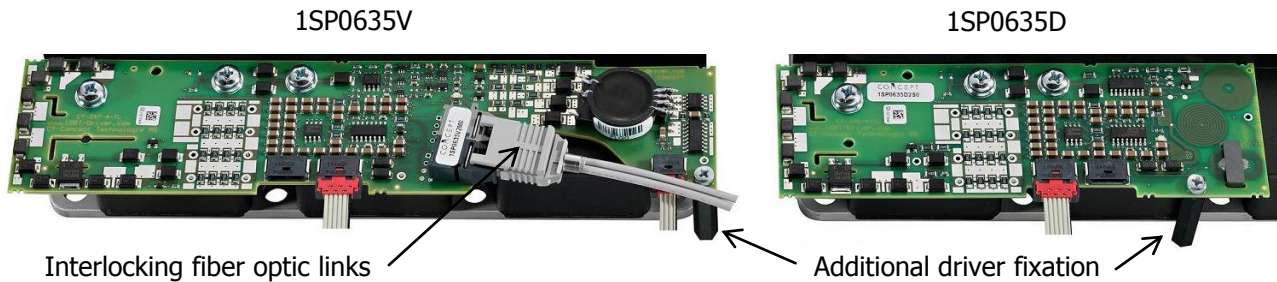

Fig. 24 Additional measures for fixing the drivers (1SP0635V/1SP0635S left, 1SP0635D right) as well as the relevant version of interlocking fiber-optic links for the 1SP0635V

References

- /1/ Paper: Smart Power Chip Tuning, Bodo's Power Systems, May 2007
- /2/ Description and Application Manual for SCALE™ Drivers, CONCEPT
- /3/ Data sheets of SCALE™-2 plug-and-play driver 1SP0635x2xx-xxx, CONCEPT
- /4/ Paper: Advantages of Advanced Active Clamping, Power Electronics Europe, Nov/Dec 2009
- /5/ Application Note AN-0901: Methodology for Controlling Multi-Level Converter Topologies with SCALE™-2 IGBT Drivers, CONCEPT

Note: The Application Notes are available on the Internet at www.igbt-driver.com/go/app-note and the papers at www.IGBT-Driver.com/go/paper

Preliminary Description and Application Manual

The Information Source: SCALE-2 Driver Data Sheets

CONCEPT offers the widest selection of gate drivers for power MOSFETs and IGBTs for almost any application needs. The largest website on gate-drive circuitry anywhere contains all data sheets, application notes and manuals, technical information and support sections: www.IGBT-Driver.com

Quite Special: Customized SCALE-2 Drivers

If you need an IGBT driver that is not included in the delivery range, please don't hesitate to contact CONCEPT or your CONCEPT sales partner.

CONCEPT has more than 25 years experience in the development and manufacture of intelligent gate drivers for power MOSFETs and IGBTs and has already implemented a large number of customized solutions.

Technical Support

CONCEPT provides expert help with your questions and problems:

www.IGBT-Driver.com/go/support

Quality

The obligation to high quality is one of the central features laid down in the mission statement of CT-Concept Technologie GmbH. The quality management system covers all stages of product development and production up to delivery. The drivers of the SCALE-2 series are manufactured to the ISO9001:2000 quality standard.

Legal Disclaimer

This data sheet specifies devices but cannot promise to deliver any specific characteristics. No warranty or guarantee is given – either expressly or implicitly – regarding delivery, performance or suitability.

CT-Concept Technologie GmbH reserves the right to make modifications to its technical data and product specifications at any time without prior notice. The general terms and conditions of delivery of CT-Concept Technologie GmbH apply.

Preliminary Description and Application Manual

Ordering Information

See the current list on www.IGBT-Driver.com/go/1SP0635

Refer to www.IGBT-Driver.com/go/nomenclature for information on driver nomenclature

The general terms and conditions of delivery of CT-Concept Technologie GmbH apply.

Information about Other Products

For drivers adapted to other high-voltage or high-power IGBT modules

Direct link: www.IGBT-Driver.com/go/plug-and-play

For other drivers, evaluation systems, product documentation and application support

Please click onto: www.IGBT-Driver.com

Manufacturer

CT-Concept Technologie GmbH
A Power Integrations Company
Johann-Renfer-Strasse 15
2504 Biel-Bienne
Switzerland

Phone +41 - 32 - 344 47 47

Fax +41 - 32 - 344 47 40

E-mail Info@IGBT-Driver.com

Internet www.IGBT-Driver.com

© 2010...2014 CT-Concept Technologie GmbH - Switzerland

We reserve the right to make any technical modifications without prior notice.

All rights reserved.
Version 2.0 from 2014-05-12

Mouser Electronics

Authorized Distributor

Click to View Pricing, Inventory, Delivery & Lifecycle Information:

Power Integrations:

[MBC41-110-0](#) [MBC61-110-0](#) [MBC61-70-0](#) [MBCON-4-1-0](#) [MBC61-070-0](#)



Компания «ЭлектроПласт» предлагает заключение долгосрочных отношений при поставках импортных электронных компонентов на взаимовыгодных условиях!

Наши преимущества:

- Оперативные поставки широкого спектра электронных компонентов отечественного и импортного производства напрямую от производителей и с крупнейших мировых складов;
- Поставка более 17-ти миллионов наименований электронных компонентов;
- Поставка сложных, дефицитных, либо снятых с производства позиций;
- Оперативные сроки поставки под заказ (от 5 рабочих дней);
- Экспресс доставка в любую точку России;
- Техническая поддержка проекта, помощь в подборе аналогов, поставка прототипов;
- Система менеджмента качества сертифицирована по Международному стандарту ISO 9001;
- Лицензия ФСБ на осуществление работ с использованием сведений, составляющих государственную тайну;
- Поставка специализированных компонентов (Xilinx, Altera, Analog Devices, Intersil, Interpoint, Microsemi, Aeroflex, Peregrine, Syfer, Eurofarad, Texas Instrument, Miteq, Cobham, E2V, MA-COM, Hittite, Mini-Circuits, General Dynamics и др.);

Помимо этого, одним из направлений компании «ЭлектроПласт» является направление «Источники питания». Мы предлагаем Вам помощь Конструкторского отдела:

- Подбор оптимального решения, техническое обоснование при выборе компонента;
- Подбор аналогов;
- Консультации по применению компонента;
- Поставка образцов и прототипов;
- Техническая поддержка проекта;
- Защита от снятия компонента с производства.



Как с нами связаться

Телефон: 8 (812) 309 58 32 (многоканальный)

Факс: 8 (812) 320-02-42

Электронная почта: org@eplast1.ru

Адрес: 198099, г. Санкт-Петербург, ул. Калинина, дом 2, корпус 4, литера А.