

High Precision 4-Terminal Power Current Sensing Resistors with TCR as low as $\pm 3 \text{ ppm}/^\circ\text{C}$ Maximum, Tolerance to $\pm 0.5 \%$ and Load Life Stability $\pm 0.02 \%$ (200 ppm) at 25°C , 2000 h at Rated Power

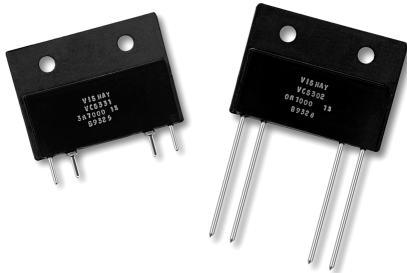

INTRODUCTION

The VCS301 and VCS302 offer precision resistors as low as $5 \text{ m}\Omega$ with a temperature coefficient down to $3 \text{ ppm}/^\circ\text{C}$ maximum and unmatched long term stability. The 4 terminal current sensing resistors, when mounted on a heat sink, can sustain 10 W continuously without an appreciable change in resistance (0.15% maximum). The typical 50% power derating specification associated with other technologies is not necessary. A choice of lead configurations is available.

Our application engineering department is available to advise and make recommendations. For non-standard technical requirements and special applications, please contact us.

FEATURES

- Temperature coefficient of resistance (TCR): down to $\pm 3 \text{ ppm}/^\circ\text{C}$ max. (see table 2)
- Tolerance: to $\pm 0.5 \%$ (see table 1)
- Power rating (heat-sinked): 10 W
- Load life stability: $\pm 0.02 \%$ (200 ppm) at 25°C , 2000 h at rated power
- Resistance range: 0.005Ω to 0.25Ω
- Vishay Foil resistors are not restricted to standard values; specific "as required" values can be supplied at no extra cost or delivery (e.g. $0R123$ vs. $0R1$)
- Non inductive, non capacitive design
- Rise time: 1.0 ns effectively no ringing
- Thermal EMF: $0.05 \mu\text{V}/^\circ\text{C}$ typical
- Voltage coefficient: $< 0.1 \text{ ppm}/\text{V}$
- Non inductive: $0.08 \mu\text{H}$
- Non hot spot design
- Terminal finish: lead (Pb)-free or tin/lead alloy
- Compliant to RoHS directive 2002/95/EC
- Prototype quantities available in just 5 working days or sooner. For more information, please contact foil@vishaypg.com
- For better performances, please contact application engineering



RoHS*
COMPLIANT

TABLE 1 - CHARACTERISTICS

MODEL NUMBER	RESISTANCE RANGE	TOLERANCE (1)	POWER RATING (2) at $+25^\circ\text{C}$	MAXIMUM CURRENT (2)
VCS301, VCS302	$0.005 \Omega < R < 0.1 \Omega$	$\pm 1 \%$	10 W on heat sink (3)	15 A
	$0.1 \Omega \leq R < 0.25 \Omega$	$\pm 0.5 \%$	or 3 W in free air	

Notes

1. Tighter tolerance is available - for more details contact application engineering
2. The lower of the two limitations (power or current) is decisive
3. Heatsink - aluminum ($6''$ length x $4''$ width x $2''$ height x $0.04''$ thick)

TABLE 2 - TCR CHART (MAXIMUM)

(0 °C TO +60 °C)		
$\geq 0.005 \Omega$	to $< 0.01 \Omega$	$\pm 15 \text{ ppm}/^\circ\text{C}$
$\geq 0.01 \Omega$	to $< 0.05 \Omega$	$\pm 10 \text{ ppm}/^\circ\text{C}$
$\geq 0.05 \Omega$	to $< 0.1 \Omega$	$\pm 5 \text{ ppm}/^\circ\text{C}$
$\geq 0.1 \Omega$	to $< 0.25 \Omega$	$\pm 3 \text{ ppm}/^\circ\text{C}$

FIGURE 1 - POWER DERATING CURVE

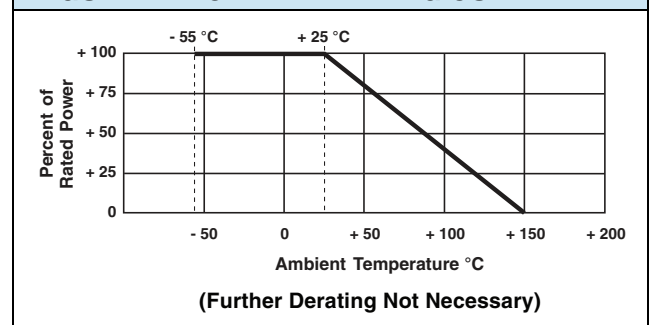

* Pb containing materials are not RoHS compliant, exemptions may apply

FIGURE 2 - DIMENSIONS in inches (millimeters) **AND SCHEMATIC**

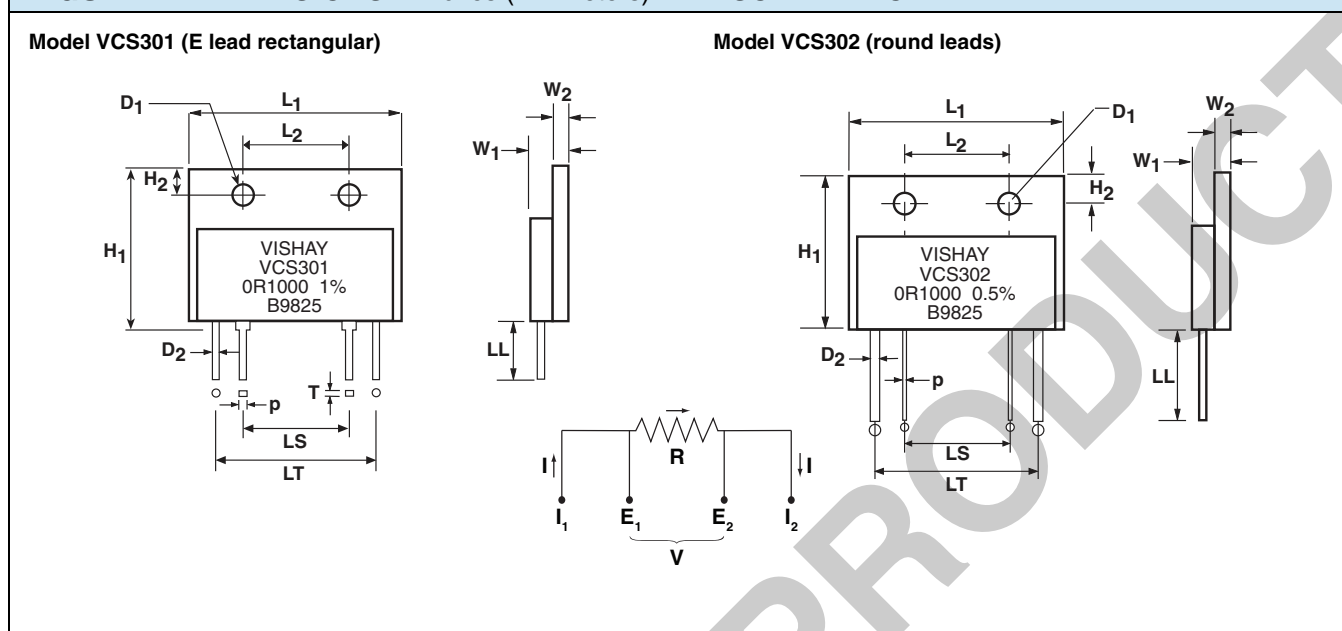

MODEL	L ₁ ± 0.008 (± 0.20)	L ₂ ± 0.008 (± 0.20)	H ₁ MAXIMUM	H ₂ ± 0.008 (± 0.20)	W ₁ MAXIMUM	W ₂ MAXIMUM	LL MINIMUM	LS ± 0.020 (± 0.51)	LT ± 0.020 (± 0.51)	D ₁ NOMINAL	D ₂ NOMINAL	P NOMINAL	T NO
VCS301	1.340 (34.04)	0.701 (17.81)	1.063 (27.00)	0.197 (5.00)	0.210 (5.33)	0.087 (2.21)	0.216 (5.49)	0.689 (17.50)	1.083 (27.51)	0.138 (3.51)	0.040 (1.02)	0.040 (1.02)	0.016 (0.41)
VCS302	1.340 (34.04)	0.701 (17.81)	1.024 (26.01)	0.197 (5.00)	0.210 (5.33)	0.087 (2.21)	1.000 (25.40)	0.689 (17.50)	1.083 (27.51)	0.138 (3.51)	0.040 (1.02)	0.032 (0.81)	-

TABLE 3 - VISHAY VCS301, VCS302 PERFORMANCE

TEST OR CONDITION	VCS301, VCS302 PERFORMANCE ⁽¹⁾	
	TYPICAL ΔR LIMITS	MAXIMUM ΔR LIMITS
Thermal Shock	0.01 %	0.02 %
Short Time Overload (5 x Rated Power for 5 s)	0.01 %	0.02 %
Terminal Strength	0.02 %	0.05 %
High Temperature Exposure (2000 h at 150 °C)	0.02 %	0.05 %
Moisture Resistance	0.03 %	0.05 %
Low Temperature Storage (24 h at - 55 °C)	0.005 %	0.01 %
Shock (Specified Pulse)	0.01 %	0.02 %
Vibration (High Frequency)	0.01 %	0.02 %
Load Life (Rated Power, + 25 °C, 2000 h)	0.02 %	0.05 %
Resistance Tolerance	0.5 %	1 %
Thermal EMF	0.2 μV/°C max. (E terminal)	
Weight	8.1 g maximum	

Notes

- ΔR's plus additional 0.0005 Ω for measurement error
- All measurements done in free air

TABLE 4 - GLOBAL PART NUMBER INFORMATION (1)

NEW GLOBAL PART NUMBER: Y09590R25000D9L (preferred part number format)

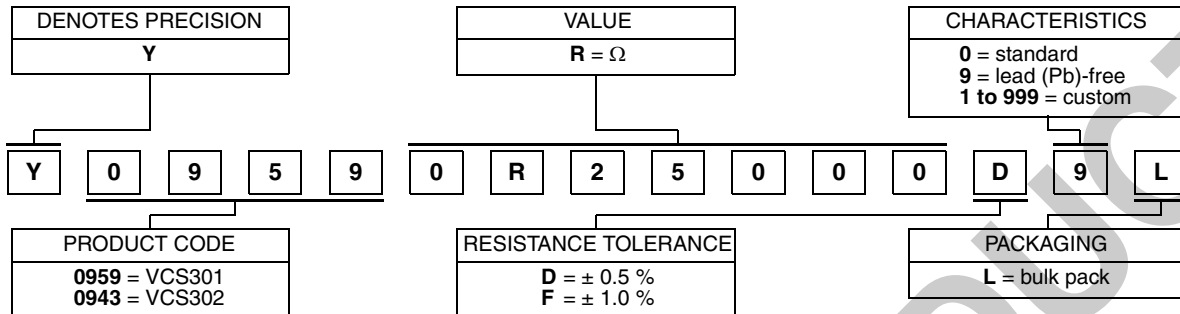

FOR EXAMPLE: ABOVE GLOBAL ORDER Y0959 0R25000 D 9 L:

TYPE: VCS301
VALUE: $0.25\ \Omega$
ABSOLUTE TOLERANCE: $\pm 0.5\%$
TERMINATION: lead (Pb)-free
PACKAGING: bulk

HISTORICAL PART NUMBER: VCS301T 0R2500 D B (will continue to be used)

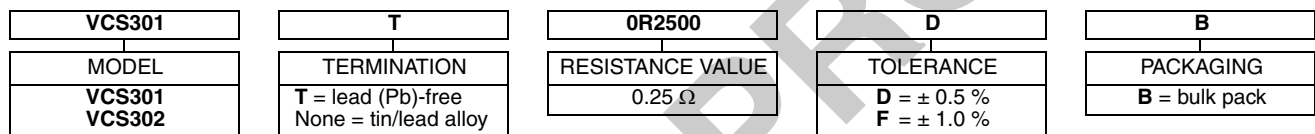

Note

(1) For non-standard requests, please contact application engineering



Disclaimer

ALL PRODUCTS, PRODUCT SPECIFICATIONS AND DATA ARE SUBJECT TO CHANGE WITHOUT NOTICE.

Vishay Precision Group, Inc., its affiliates, agents, and employees, and all persons acting on its or their behalf (collectively, "VPG"), disclaim any and all liability for any errors, inaccuracies or incompleteness contained herein or in any other disclosure relating to any product.

The product specifications do not expand or otherwise modify VPG's terms and conditions of purchase, including but not limited to, the warranty expressed therein.

VPG makes no warranty, representation or guarantee other than as set forth in the terms and conditions of purchase. **To the maximum extent permitted by applicable law, VPG disclaims (i) any and all liability arising out of the application or use of any product, (ii) any and all liability, including without limitation special, consequential or incidental damages, and (iii) any and all implied warranties, including warranties of fitness for particular purpose, non-infringement and merchantability.**

Information provided in datasheets and/or specifications may vary from actual results in different applications and performance may vary over time. Statements regarding the suitability of products for certain types of applications are based on VPG's knowledge of typical requirements that are often placed on VPG products. It is the customer's responsibility to validate that a particular product with the properties described in the product specification is suitable for use in a particular application. You should ensure you have the current version of the relevant information by contacting VPG prior to performing installation or use of the product, such as on our website at vpgsensors.com.

No license, express, implied, or otherwise, to any intellectual property rights is granted by this document, or by any conduct of VPG.

The products shown herein are not designed for use in life-saving or life-sustaining applications unless otherwise expressly indicated. Customers using or selling VPG products not expressly indicated for use in such applications do so entirely at their own risk and agree to fully indemnify VPG for any damages arising or resulting from such use or sale. Please contact authorized VPG personnel to obtain written terms and conditions regarding products designed for such applications.

Product names and markings noted herein may be trademarks of their respective owners.

Copyright Vishay Precision Group, Inc., 2014. All rights reserved.



Компания «ЭлектроПласт» предлагает заключение долгосрочных отношений при поставках импортных электронных компонентов на взаимовыгодных условиях!

Наши преимущества:

- Оперативные поставки широкого спектра электронных компонентов отечественного и импортного производства напрямую от производителей и с крупнейших мировых складов;
- Поставка более 17-ти миллионов наименований электронных компонентов;
- Поставка сложных, дефицитных, либо снятых с производства позиций;
- Оперативные сроки поставки под заказ (от 5 рабочих дней);
- Экспресс доставка в любую точку России;
- Техническая поддержка проекта, помощь в подборе аналогов, поставка прототипов;
- Система менеджмента качества сертифицирована по Международному стандарту ISO 9001;
- Лицензия ФСБ на осуществление работ с использованием сведений, составляющих государственную тайну;
- Поставка специализированных компонентов (Xilinx, Altera, Analog Devices, Intersil, Interpoint, Microsemi, Aeroflex, Peregrine, Syfer, Eurofarad, Texas Instrument, Miteq, Cobham, E2V, MA-COM, Hittite, Mini-Circuits, General Dynamics и др.);

Помимо этого, одним из направлений компании «ЭлектроПласт» является направление «Источники питания». Мы предлагаем Вам помощь Конструкторского отдела:

- Подбор оптимального решения, техническое обоснование при выборе компонента;
- Подбор аналогов;
- Консультации по применению компонента;
- Поставка образцов и прототипов;
- Техническая поддержка проекта;
- Защита от снятия компонента с производства.



Как с нами связаться

Телефон: 8 (812) 309 58 32 (многоканальный)

Факс: 8 (812) 320-02-42

Электронная почта: org@eplast1.ru

Адрес: 198099, г. Санкт-Петербург, ул. Калинина, дом 2, корпус 4, литера А.