

Features:

- Narrow receiving angle
- Variety of sensitivity ranges
- Enhanced temperature range
- PCBoard mounting
- Mechanically and spectrally matched to OP123 and OP223 LEDs

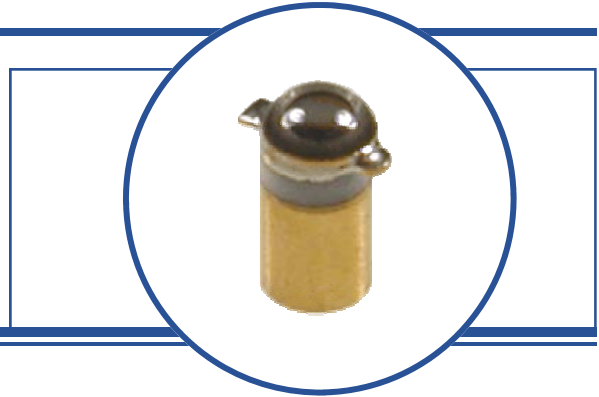

Description:

Each device in this series is a NPN silicon photodarlington in a hermetically sealed pill package with a narrow receiving angle that provides excellent on-axis coupling. Photodarlington are normally used in applications with low light signal levels, where more current gain is needed than phototransistors can provide.

Components in the OP300 series are mechanically and spectrally matched to the OP123 and OP223 series.

Please refer to Application Bulletins 208 and 210 for additional design information and reliability (degradation) data, and to Application Bulletin 202 for pill-type soldering to PCBoard.

Applications:

- Non-contact reflective object sensor
- Machine safety
- Assembly line automation
- End of travel sensor
- Machine automation
- Door sensor

Ordering Information				
Part Number	Sensor	Light Current I _{C(ON)} (mA) Min / Max	Input Power E _E (mW/cm ²)	Viewing Angle
OP300SL	Darlington	0.8 / NA	1.0 with 2870°K or 0.4 with 890nm	35°
OP301SL		0.8 / 2.4		
OP302SL		1.8 / 5.4		
OP303SL		3.6 / 12.0		
OP304SL		7.0 / 21.0		
OP305SL		14.0 / NA		

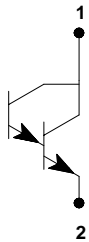

Pin #	Sensor
1	Collector
2	Emitter

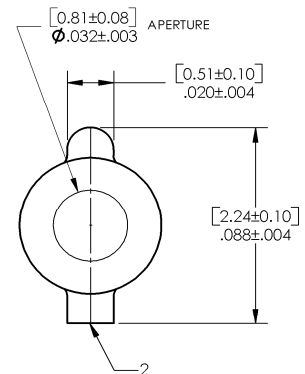
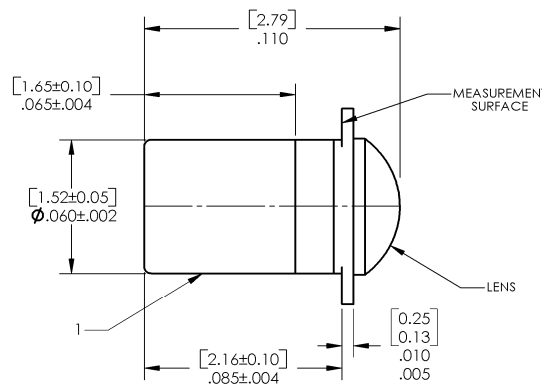

DIMENSIONS ARE IN: [MILLIMETERS]
 INCHES



RoHS

OPTEK reserves the right to make changes at any time in order to improve design and to supply the best product possible.

Absolute Maximum Ratings ($T_A=25^\circ\text{C}$ unless otherwise noted)

Collector-Emitter Voltage	15.0 V
Emitter-Collector Voltage	5.0 V
Storage Temperature Range	-65° C to +150° C
Operating Temperature Range	-65° C to +125° C
Soldering Temperature (5 seconds with soldering iron)	260° C ⁽¹⁾⁽²⁾
Power Dissipation	50 mW ⁽³⁾
Continuous Collector Current	50 mA

Electrical Characteristics ($T_A = 25^\circ\text{C}$ unless otherwise noted)

SYMBOL	PARAMETER	MIN	TYP	MAX	UNITS	TEST CONDITIONS
$I_{C(ON)}$ ⁽⁴⁾	On-State Collector Current	0.8	-	-	mA	$V_{CE} = 5.0\text{ V}, E_E = 1.0\text{ or }0.4\text{ mW/cm}^2$ ⁽⁵⁾
	OP300SL	0.8	-	2.4		
	OP301SL	1.8	-	5.4		
	OP302SL	3.6	-	12.0		
	OP303SL	7.0	-	21.0		
	OP304SL OP305SL	14.0	-	-		
I_{CEO}	Collector-Dark Current	-	-	1.0	μA	$V_{CE} = 10\text{ V}, E_E = 0$
$V_{(BR)CEO}$	Collector-Emitter Breakdown Voltage	15.0	-	-	V	$I_C = 100\ \mu\text{A}$
$V_{(BR)ECO}$	Emitter-Collector Breakdown Voltage	5.0	-	-	V	$I_E = 100\ \mu\text{A}$
$V_{CE(SAT)}$ ⁽⁴⁾	Collector-Emitter Saturation Voltage	-	-	1.1	V	$I_C = 0.4\text{ mA}, E_E = 1.0\text{ or }0.4\text{ mW/cm}^2$ ⁽⁵⁾ $I_C = 1.0\text{ mA}, E_E = 1.0\text{ or }0.4\text{ mW/cm}^2$ ⁽⁵⁾
	OP300SL, OP301SL	-	-	1.1		
	OP302SL through OP305SL	-	-	1.1		

Notes:

- (1) Refer to Application Bulletin 202, which discusses proper techniques for soldering pill-type devices to PCBoards.
- (2) No clean or low solids. RMA flux is recommended. Duration can be extended to 10 seconds maximum when flow soldering.
- (3) Derate linearly 0.5 mW/° C above 25° C.
- (4) Junction temperature maintained at 25° C.
- (5) Light source is an unfiltered tungsten bulb operating at $CT = 2870^\circ\text{K}$ at $E_E = 1.0\text{ mW/cm}^2$ or 890nm at $E_E = 0.4\text{ mW/cm}^2$.

OPTEK reserves the right to make changes at any time in order to improve design and to supply the best product possible.

Typical Spectral-Response

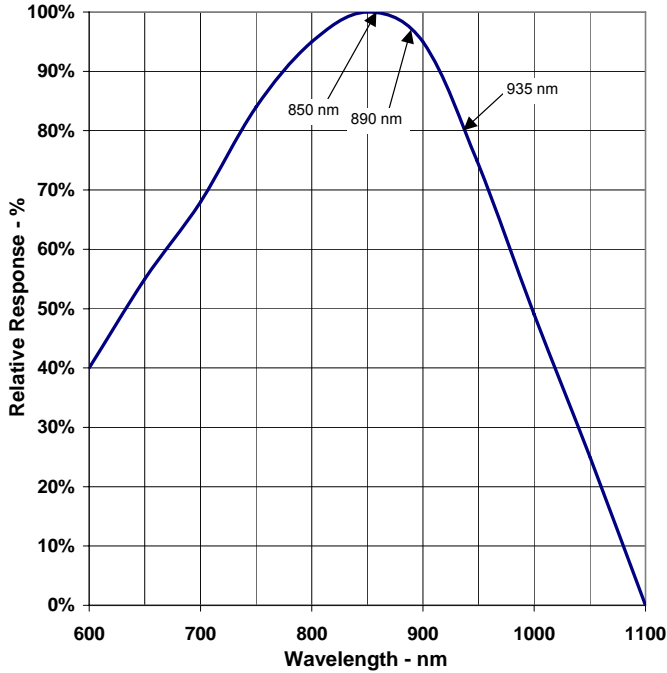

Coupling Characteristics of OP123 & OP300SL

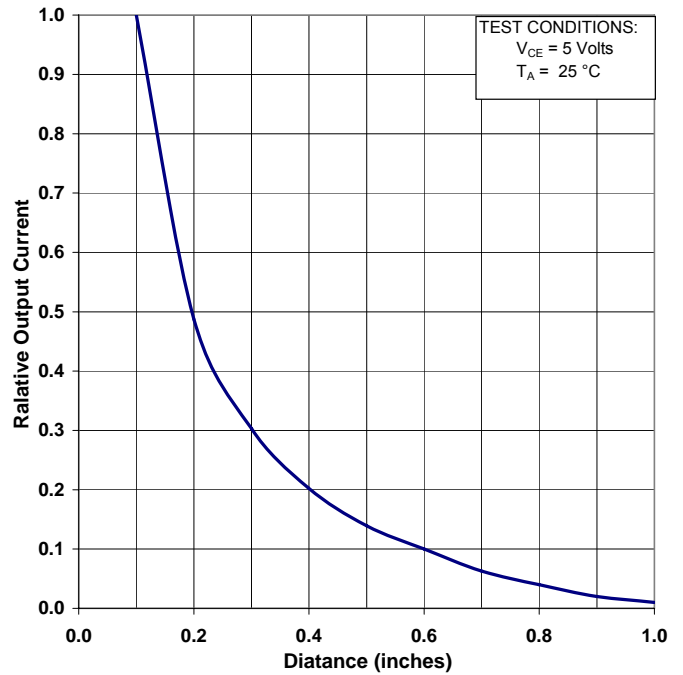

Dark Current vs Temperature

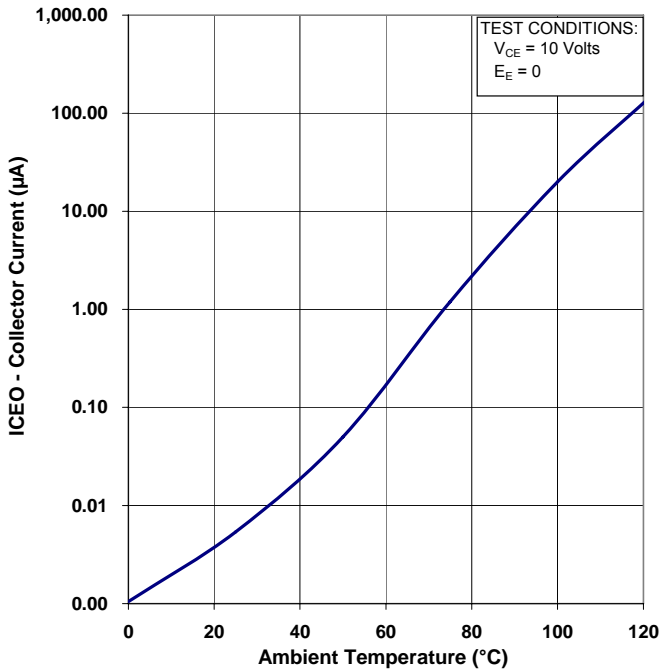

Collector Current vs Temperature

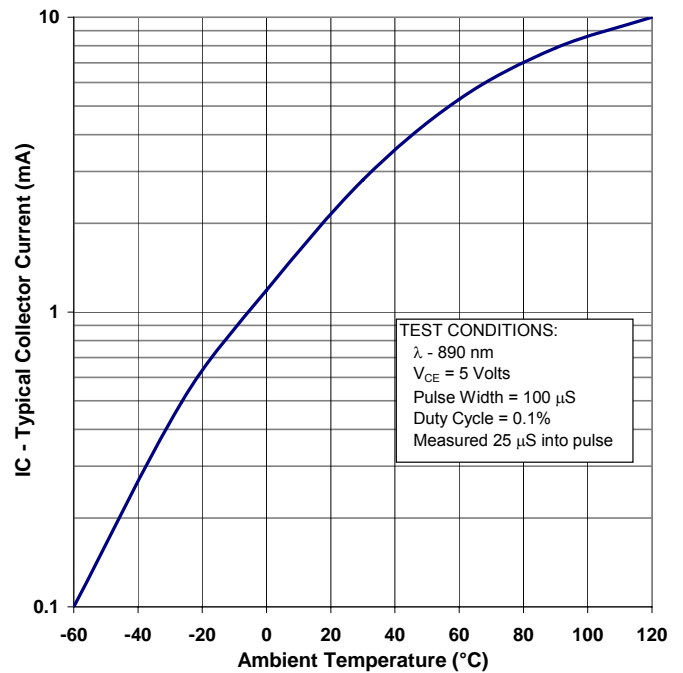

OPTEK reserves the right to make changes at any time in order to improve design and to supply the best product possible.

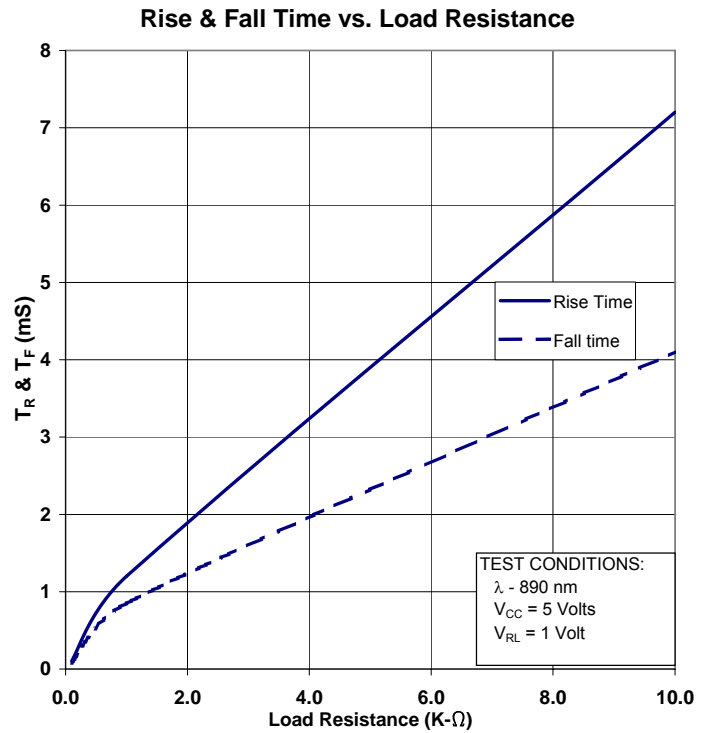
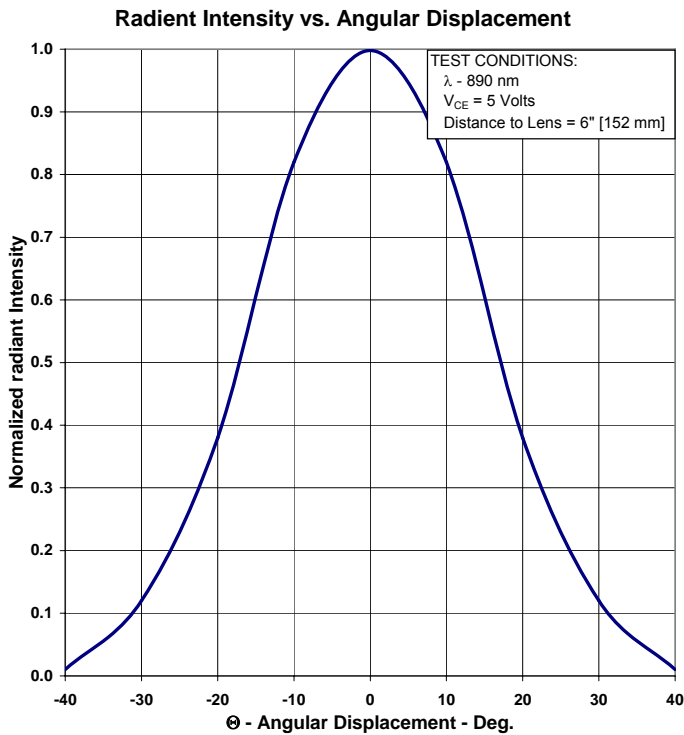

Switching time Circuit

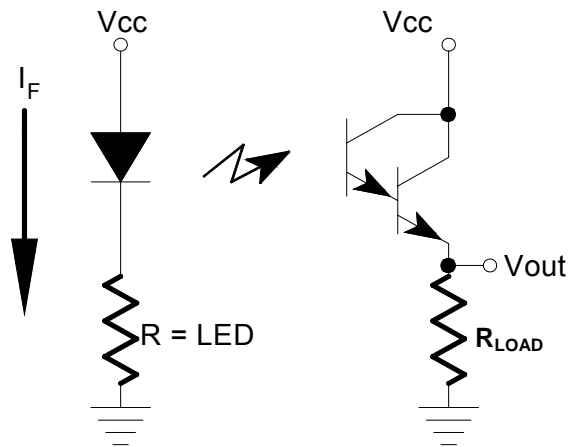

The light source is a pulsed LED with a rise time of less than 500 nS.
 The LED output is adjusted for $I_C = 0.8$ mA.

OPTEK reserves the right to make changes at any time in order to improve design and to supply the best product possible.



Компания «ЭлектроПласт» предлагает заключение долгосрочных отношений при поставках импортных электронных компонентов на взаимовыгодных условиях!

Наши преимущества:

- Оперативные поставки широкого спектра электронных компонентов отечественного и импортного производства напрямую от производителей и с крупнейших мировых складов;
- Поставка более 17-ти миллионов наименований электронных компонентов;
- Поставка сложных, дефицитных, либо снятых с производства позиций;
- Оперативные сроки поставки под заказ (от 5 рабочих дней);
- Экспресс доставка в любую точку России;
- Техническая поддержка проекта, помощь в подборе аналогов, поставка прототипов;
- Система менеджмента качества сертифицирована по Международному стандарту ISO 9001;
- Лицензия ФСБ на осуществление работ с использованием сведений, составляющих государственную тайну;
- Поставка специализированных компонентов (Xilinx, Altera, Analog Devices, Intersil, Interpoint, Microsemi, Aeroflex, Peregrine, Syfer, Eurofarad, Texas Instrument, Miteq, Cobham, E2V, MA-COM, Hittite, Mini-Circuits, General Dynamics и др.);

Помимо этого, одним из направлений компании «ЭлектроПласт» является направление «Источники питания». Мы предлагаем Вам помощь Конструкторского отдела:

- Подбор оптимального решения, техническое обоснование при выборе компонента;
- Подбор аналогов;
- Консультации по применению компонента;
- Поставка образцов и прототипов;
- Техническая поддержка проекта;
- Защита от снятия компонента с производства.



Как с нами связаться

Телефон: 8 (812) 309 58 32 (многоканальный)

Факс: 8 (812) 320-02-42

Электронная почта: org@eplast1.ru

Адрес: 198099, г. Санкт-Петербург, ул. Калинина, дом 2, корпус 4, литера А.