

FOR INFORMATION ONLY
THIS VIEWS SHOWS THE PINHEADER WITH PCB

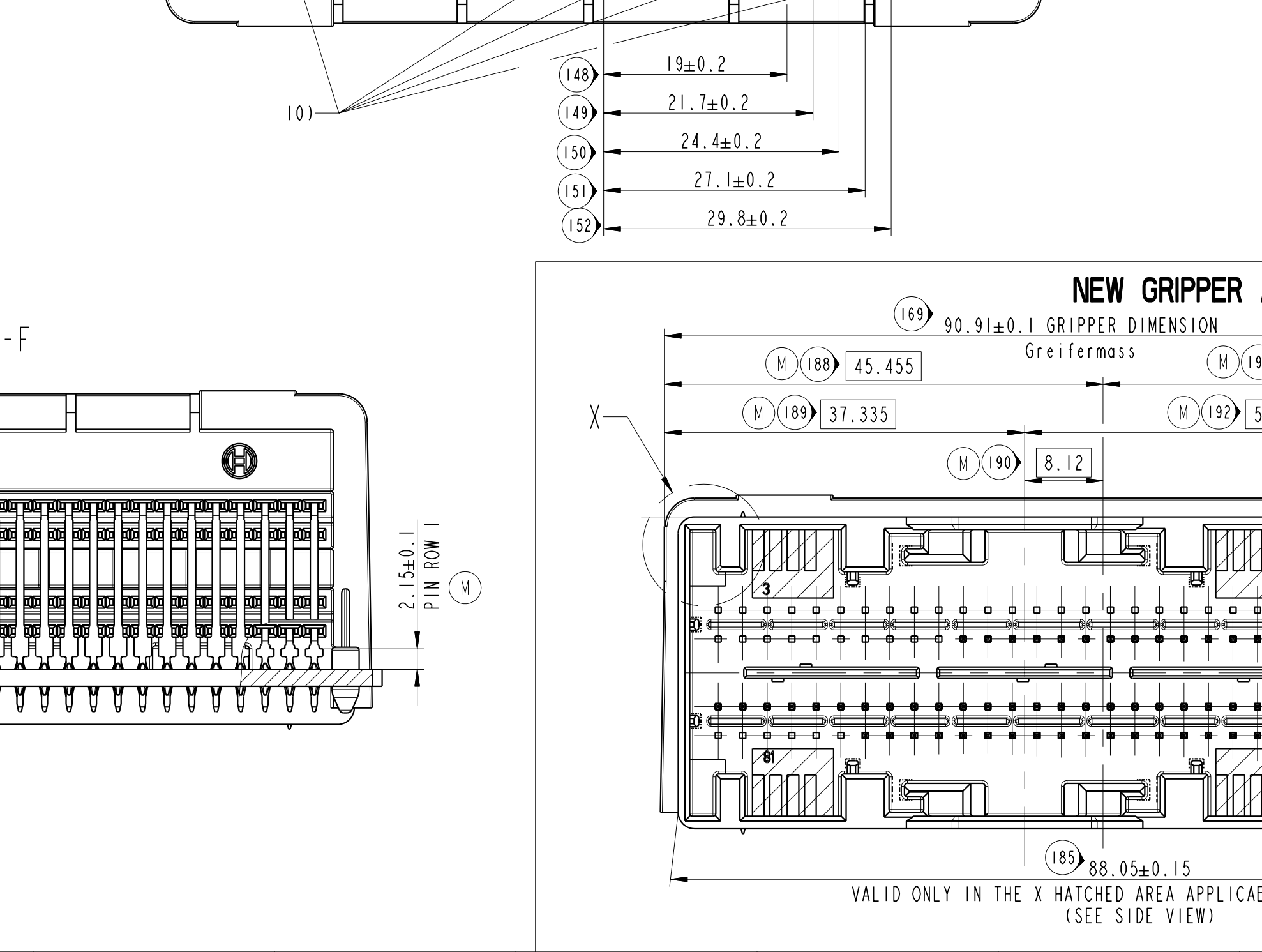

600 2 BE xxxx (ALL POSSIBLE CODINGS ARE SHOWN)

- 177 MAX 124X 0.300 C D A 2
- 189 MAX 124X 0.300 C B A 2
- 161 MAX 124X 0.300 C B A 2
- 178 MAX 124X 0.300 C D A 2

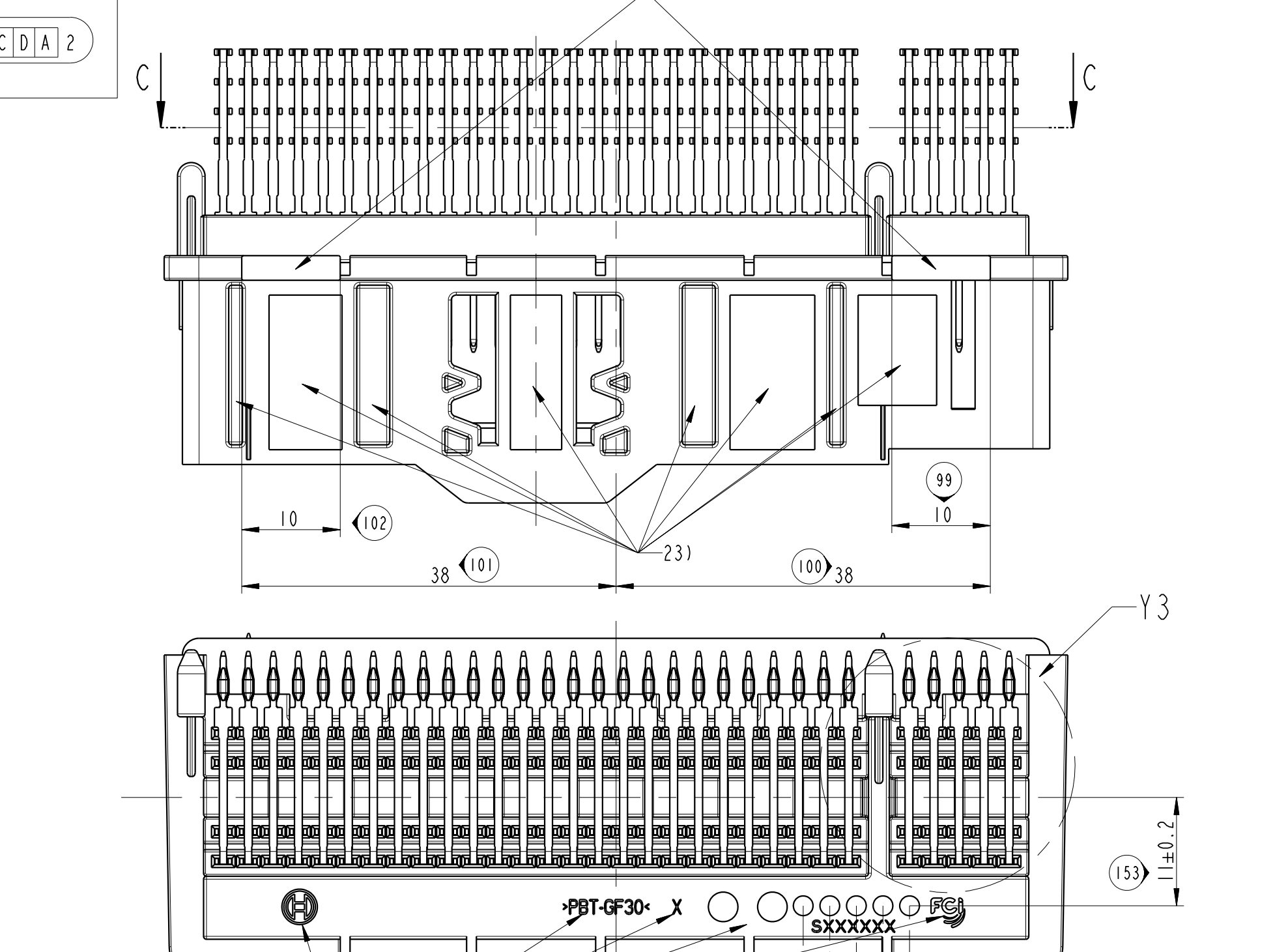
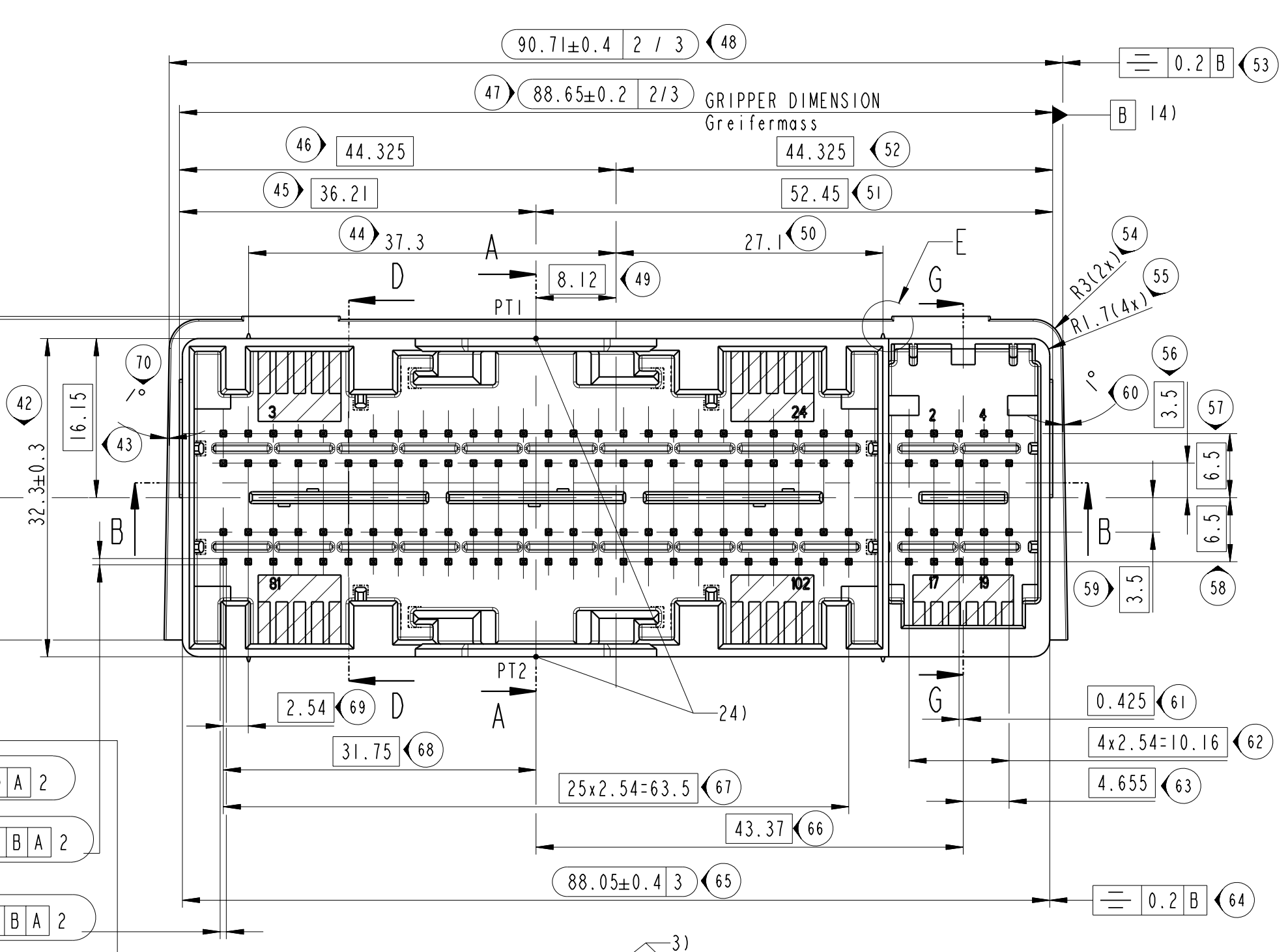
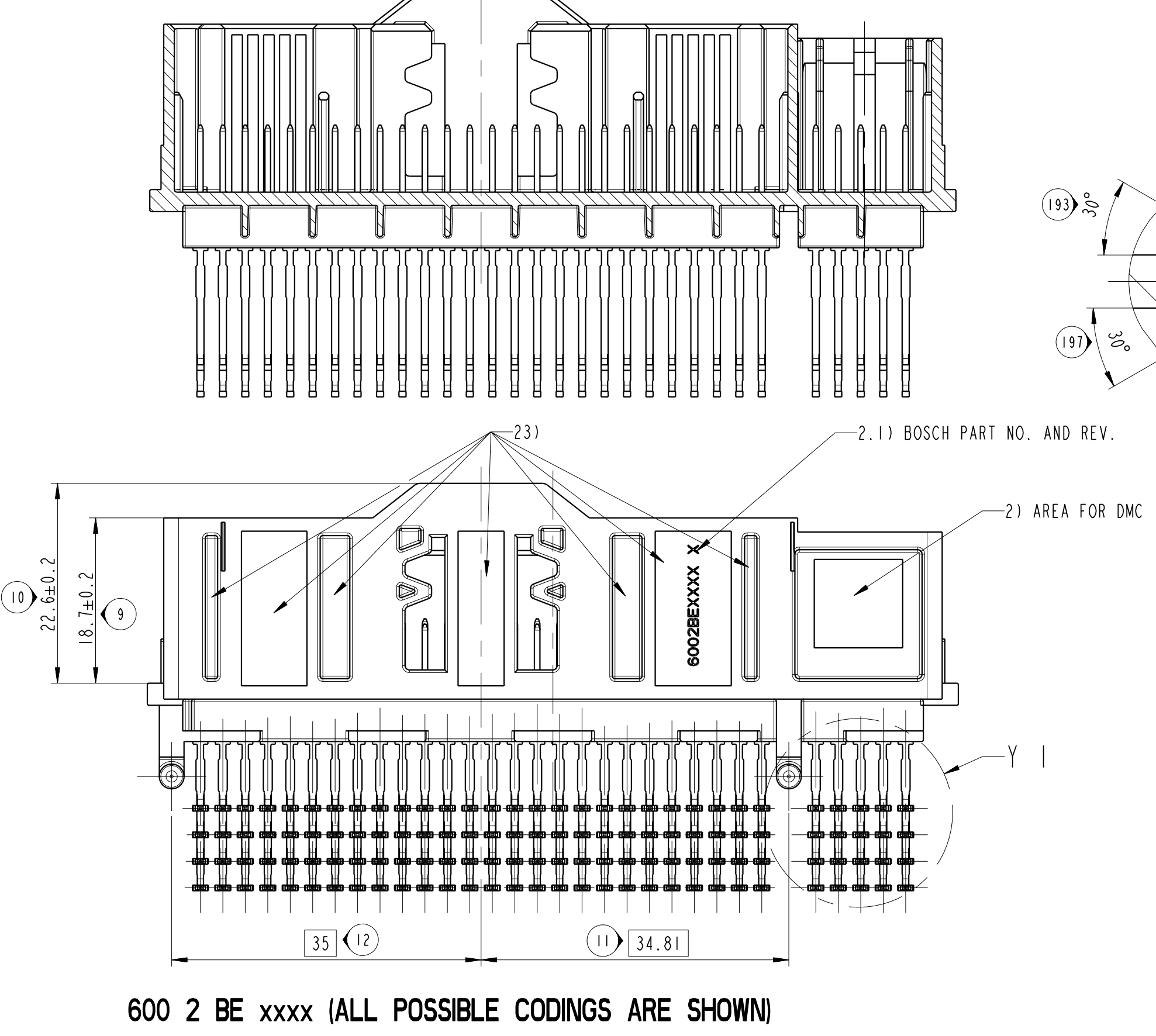
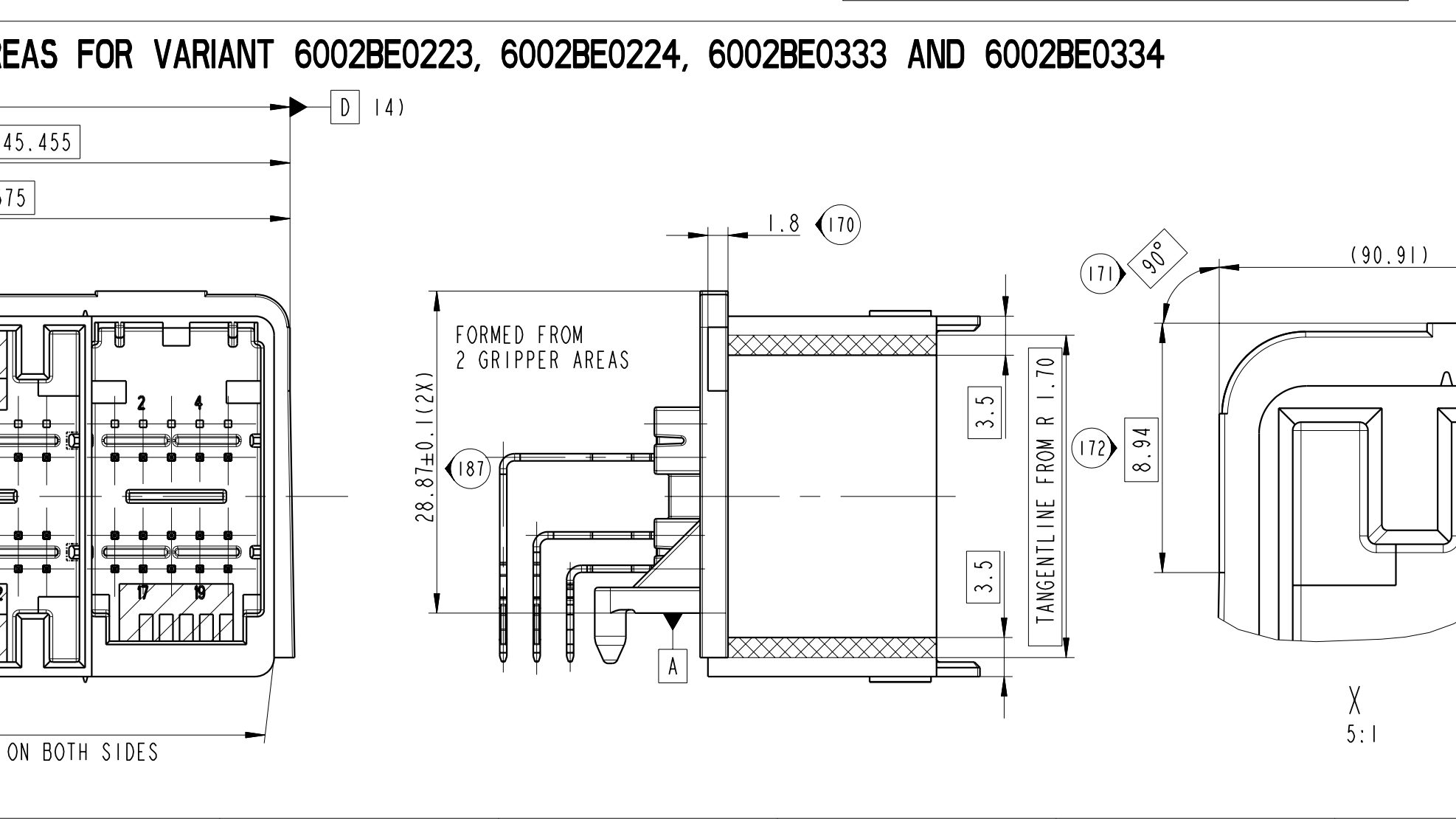
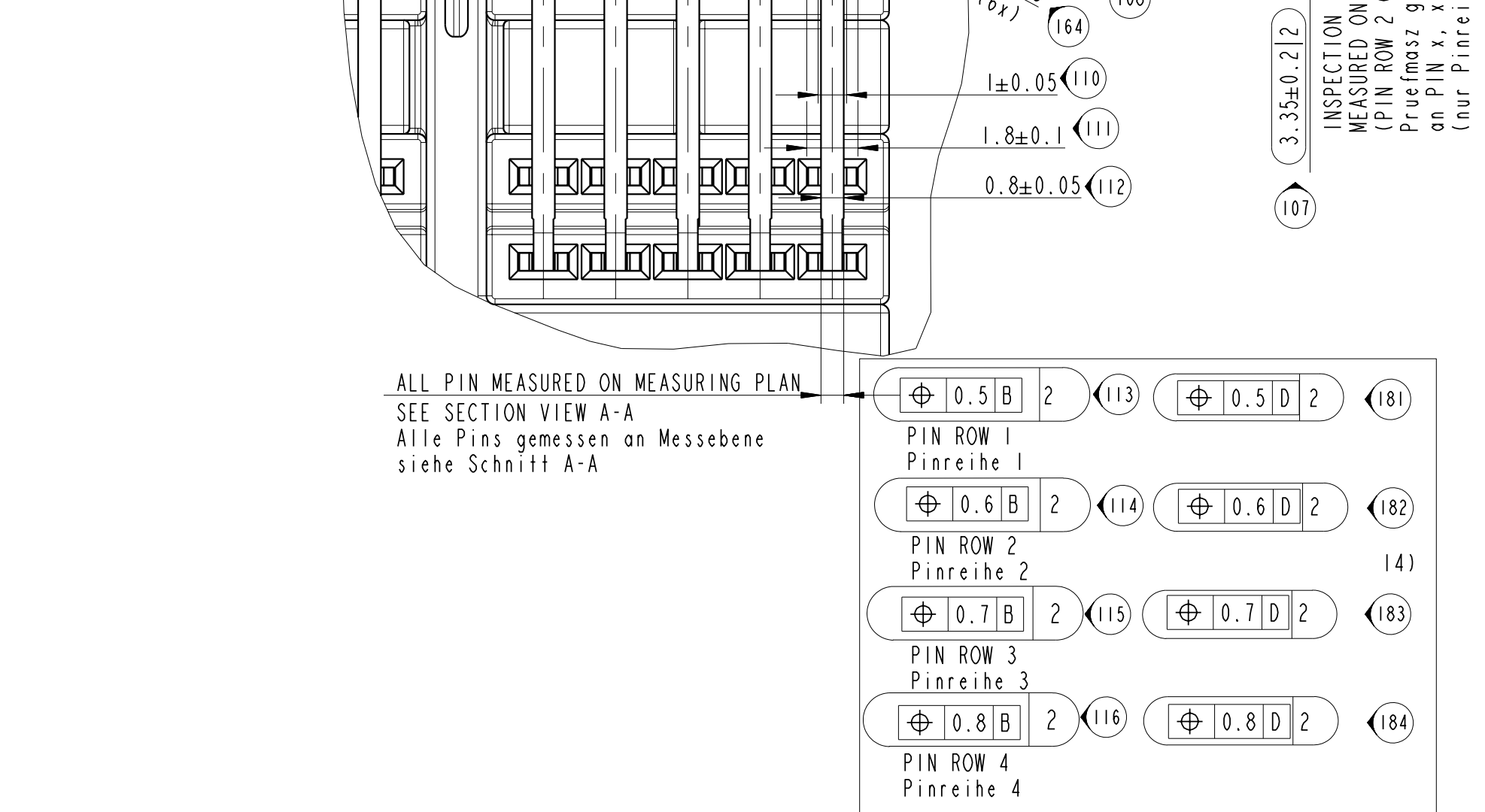
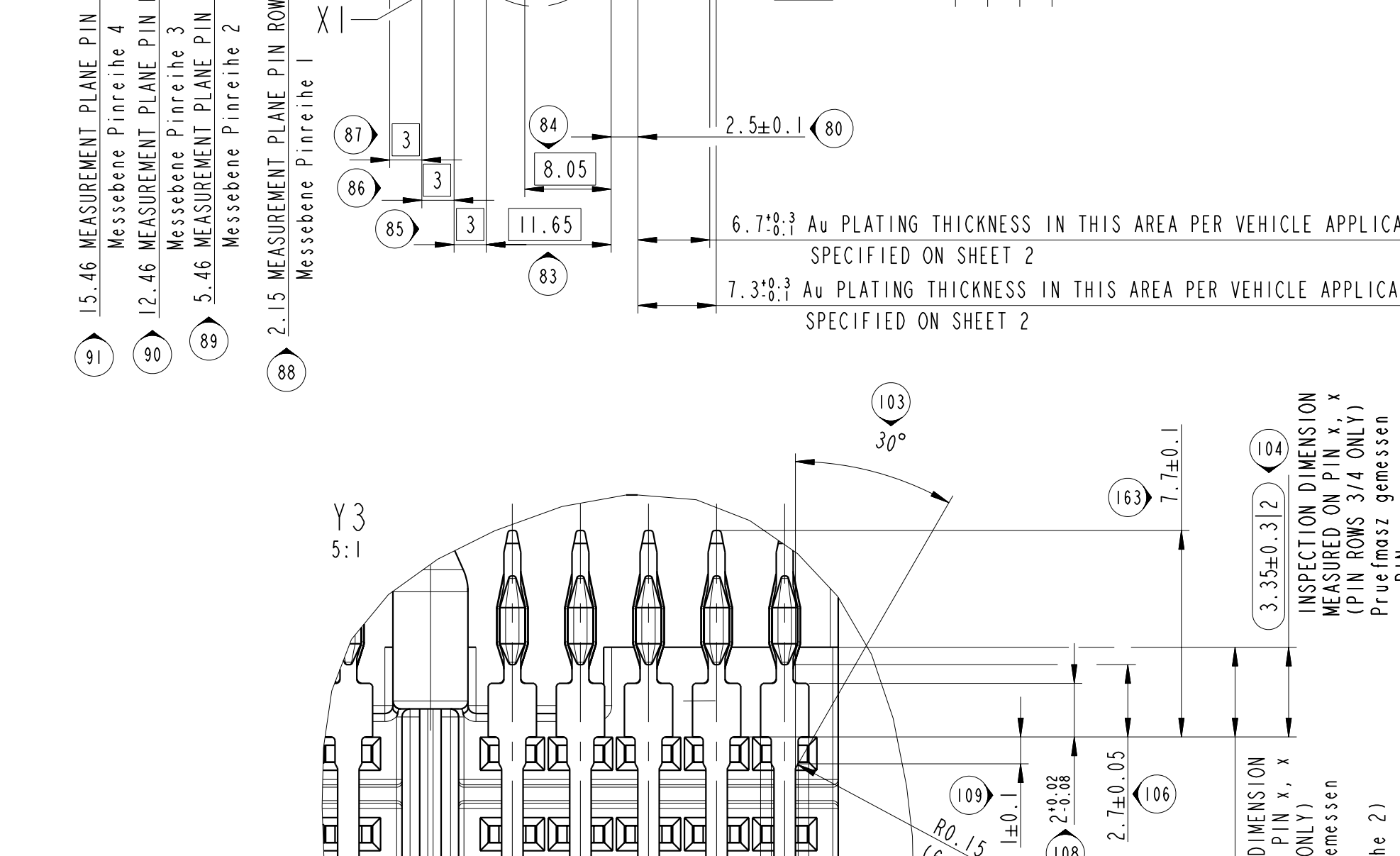
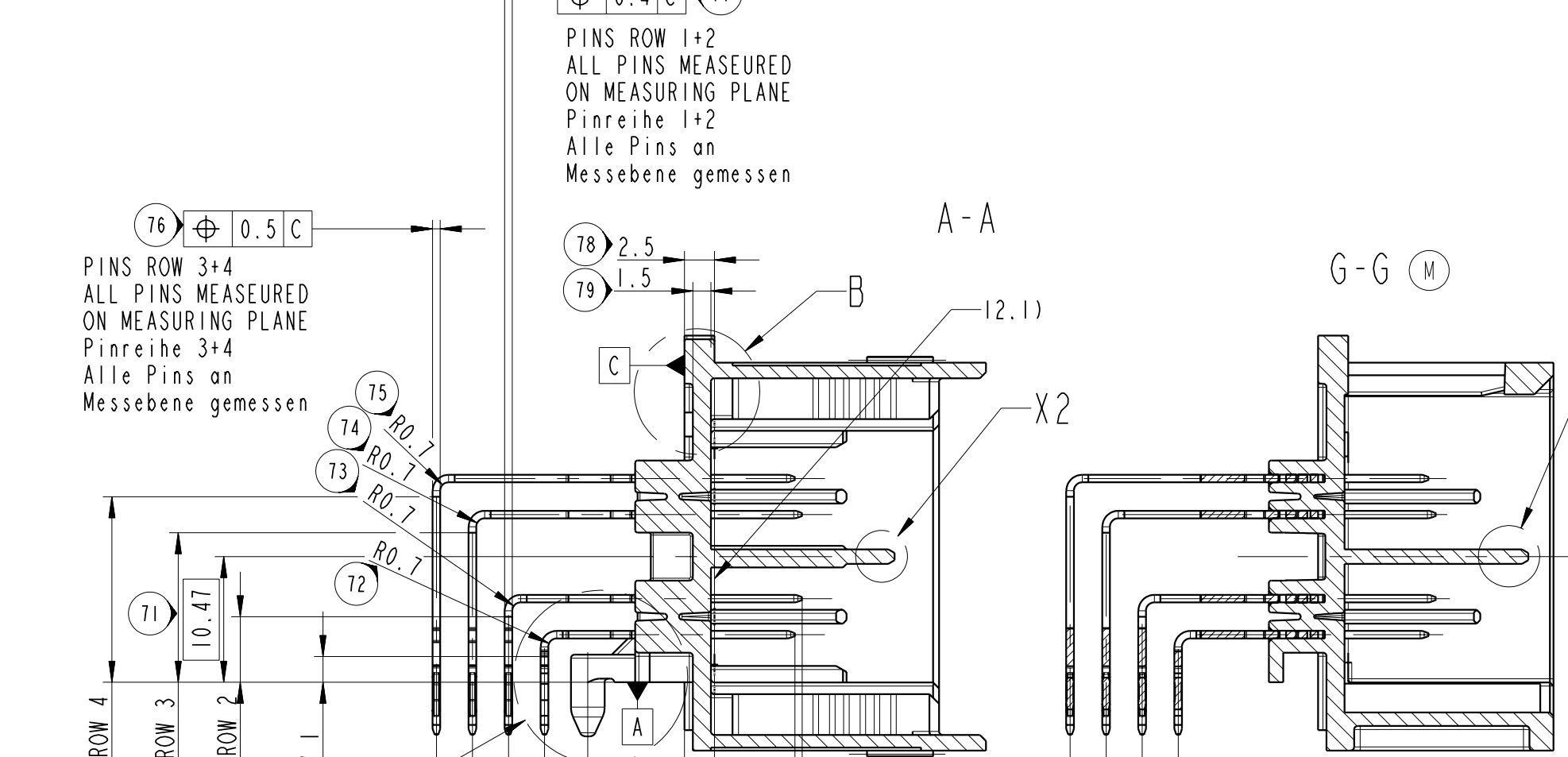
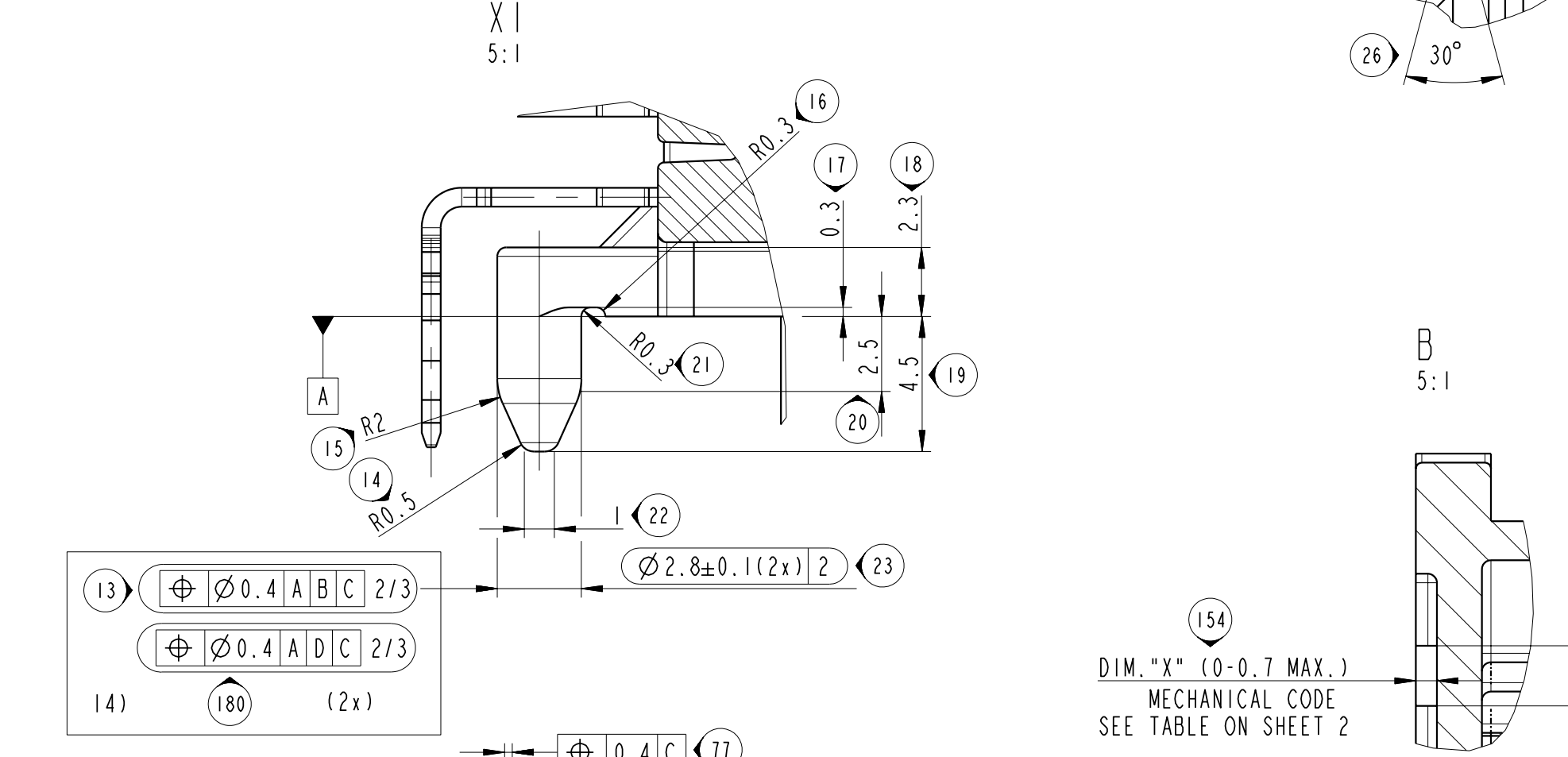
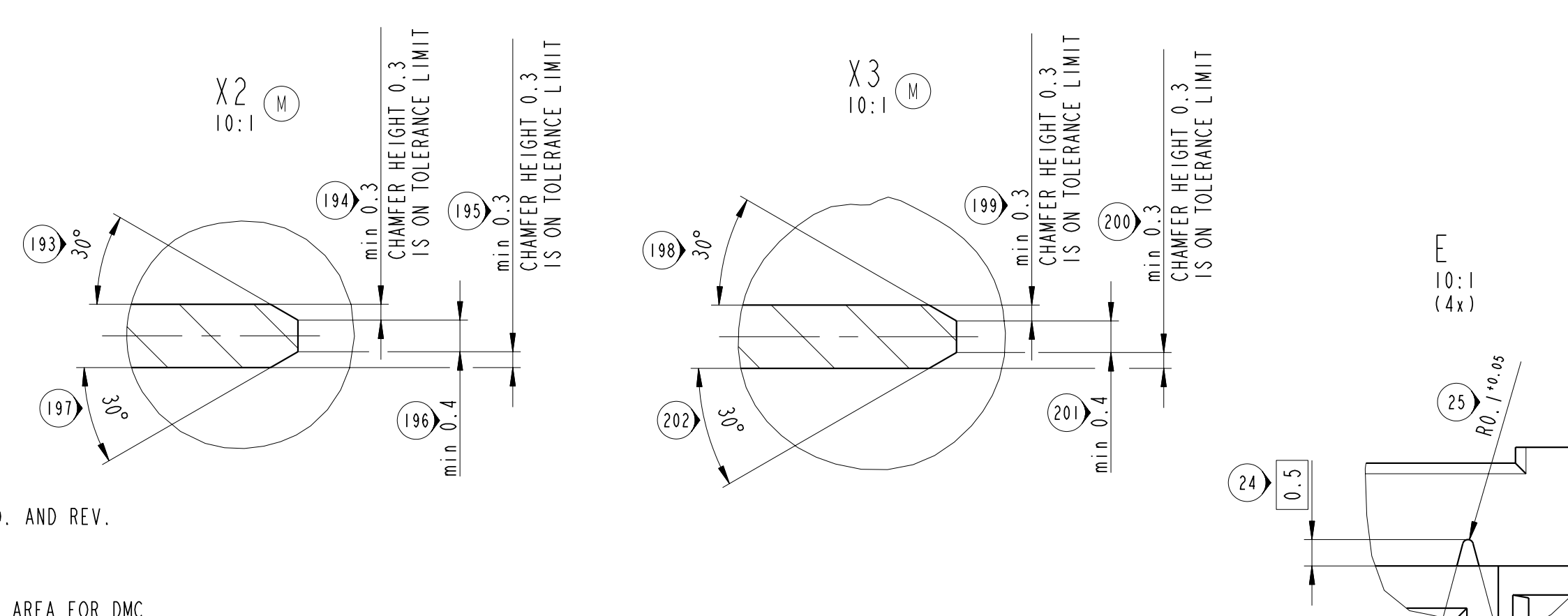

NEW GRIPPER AREAS FOR VARIANT 6002BE0223, 6002BE0224, 6002BE0333 AND 6002BE0334

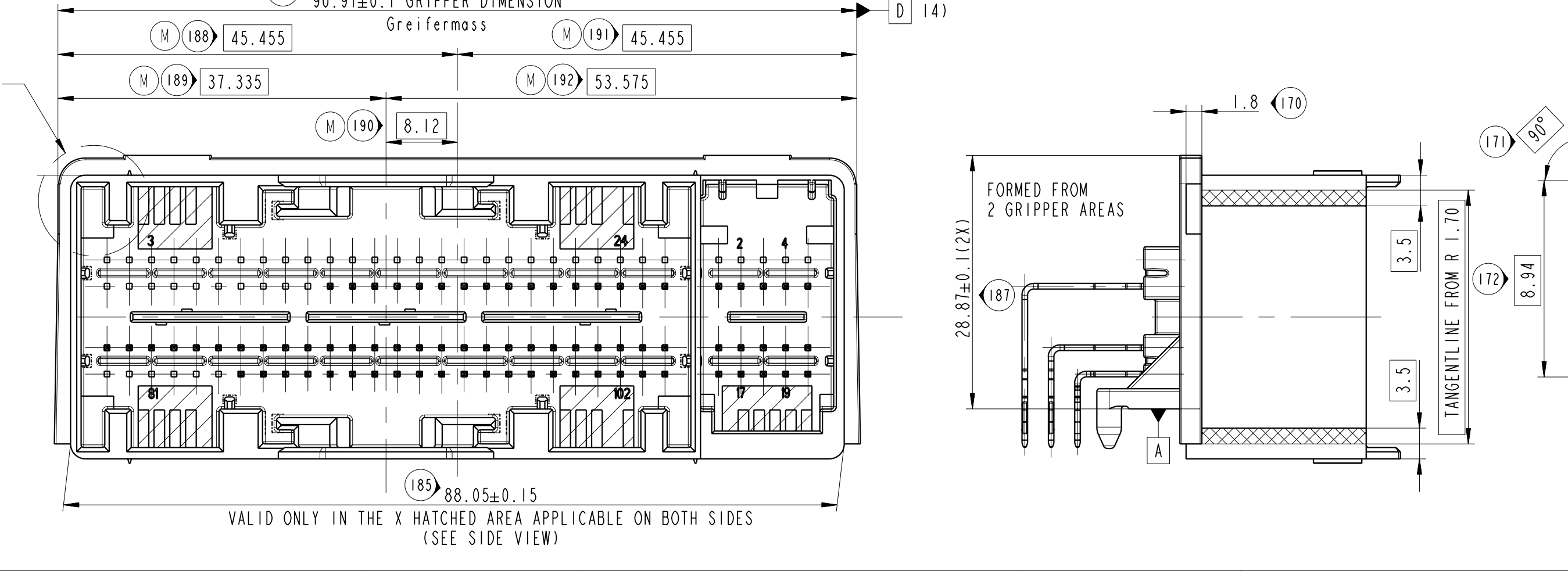

- NOTE:
- (125) MATERIAL: BASF ULTRADUR B 4300 G6 PER DAIMLER SPEC DBL 8585 PER CHRYSLER SPEC MS-DB400 CPN 2252 COLOR: Z10 YELLOW SIMILAR TO RAL1018 REGRIND 10% MAX., SPROU RECYCULATION.
 - (126) DATA MATRIX CODE SURFACE (IN THIS AREA ACC. TO VDI 3400 24 Data Matrix Code (22-digits) YEAR/MONTH/DAY (6 DIGITS) SUPPLIER CODE (6 DIGITS) LAST 4 BOSCH NO. (4 DIGITS) HOUR/ MINUTES (4 DIGITS) 2.1) BOSCH PART NO. AND REV. LASER LETTERING.
 - (127) SUPPORT AREAS FOR GRIPPER
 - (128) THE TOLERANCES NOT SHOWN SHOULD BE ACCORDING TO DIN 16901-130 FOR ALL LINEAR DIMENSIONS, ANGLE, FORM AND POSITIONAL TOLERANCES ACCORDING TO DIN ISO 2166-mr. THIS PRINT ONLY SHOWS DIMENSIONS THAT ARE ESSENTIAL TO THE FUNCTION OF THE PART! THEREFORE THE PART MUST BE DEVELOPED FROM THE SOLID MODEL PCC0559303. SOLID MODEL TO BE CONSIDERED BASIC. ALL NON DIMENSIONED FEATURES (1) A | B | C
 - (129) 5) SHOWN IS THE COMPLETE ASSEMBLY OF THE PINS, CODINGS AND GRIPPER AREA VARIANTS SEE SHEET 2 FOR PIN POPULATION, KEY CODING OPTIONS AND GRIPPER AREA VARIANTS
 - (130) 6) DE-POPULATED PIN CAVITIES SEE SHEET 2.
 - (131) 7) MOLD SEPARATION MISMATCH MAX. 0.10 EJECTOR MARKS FLUSH OR 0.2mm MAX BELOW THE SURFACE. PART MUST BE FREE OF TOOL MARKS OR FLASHINGS WHICH MAY BE DETRIMENTAL TO THE SATISFACTORY ASSEMBLY, SAFE HANDLING APPEARANCE OR FUNCTION.
 - (132) 8) DRAFT ANGLES TO BE MEASURED WITHIN THE TOLERANCE
 - (133) 9) PARTS MUST BE FREE OF GREASE, SIZE OF FOREIGN PARTICLES ACCORDING TO TECHNICAL CLEANLINES SPECIFICATION PV 1 279 921 533 AND APPENDIX 1 279 921 538
 - (134) 10) BOSCH FIGURE BRAND / MATERIAL DESCRIPTION MOLD DESCRIPTION / DATE OF PRODUCTION / MANUFACTURER LOGO TYPE PER BOSCH NORM NA14
 - (135) 11) ADJUSTMENT OF THE PARTS DURING MEASUREMENT BY REFERENCES "a" "b" "c"
 - (136) 12) MISSING DIMENSION AND INFORMATION FOR THE MATING INTERFACE GEOMETRY REFER TO: FC1 SPECIFICATION NO. PCC0605537 REV. B - 104 WAY INTERFACE DAIMLER FC1 SPECIFICATION NO. PCC060582 REV. A - 20 WAY INTERFACE DAIMLER FC1 SPECIFICATION NO. PCC063187 REV. C - 104 WAY INTERFACE CHRYSLER FC1 SPECIFICATION NO. PCC063189 REV. C - 20 WAY INTERFACE CHRYSLER
 - (137) 13) DATUM PLANE FOR INTERFACES
 - (138) 12.3) DATUM PLANE REFERENCES SEE INTERFACE DRAWINGS
 - (139) 12.3) PIN NOT SEE SHEET 2 Pin number 1. siehe Blatt 2
 - (131) 13) PRESSFIT ZONE ACC. TO DRAWING NO. 9 909 00 53 PRESS FIT PIN CONTACT MATERIAL Cu54 PLATING: MATING SIDE Ni/Au / PRESSFIT SIDE Ni 1.3-2.2µm, Sn FLASH 0.2-0.45µm
 - (138) 14) DATUM PLANE B AND D IS DEPENDENT ON THE VARIANTS CHRYSLER OR DAIMLER
 - (139) 15) DIMENSION AND/OR CHARACTERISTIC REQUIRES MEASUREMENT OR ATTRIBUTE DATA THIS INFORMATION SHALL BE REFLECTED IN THE SUPPLIER CONTROL PLAN (1) Epk = 1.33 (2) INSPECTION (3) STRESS RELIEVING
 - (140) 16) DIMENSIONS IDENTIFIED BY THE STRESS RELIEVING SYMBOL TO MEET SPECIFIED VALUES WITHIN THE TOLERANCE LIMITS BEFORE AND AFTER STRESS RELIEVING FOR 24 HOURS AT 115°C. THIS TEST TO BE CONDUCTED AT PPAP AT BOSCH SPECIFIED INTERVALS ON 3 PIECES PER CAVITY. RESULTING INSPECTION VALUES WILL NOT REQUIRE PROCESS CAPABILITY. ANY DEVIATIONS TO THE SPECIFIED LIMITS WILL REQUIRE APPROVAL FROM BOSCH ENGINEERING.
 - (141) 17) UNLESS OTHERWISE SPECIFIED, MATERIALS USED IN PRODUCTION OF THIS COMPONENT MUST NOT VIOLATE BOSCH RESTRICTED MATERIALS LIST AS DOCUMENTED IN BOSCH NORM N2580 SUPPLIERS ARE ALSO REQUIRED TO PROVIDE A FULL IMDS DISCLOSURE TO DOCUMENT SUBSTANCE COMPOSITION OF THEIR COMPONENTS.
 - (142) 18) PART MUST BE FREE FROM VOIDS
 - (143) 19) USE OF MOLD RELEASE AGENTS NOT PERMITTED
 - (144) 20) VOLUME OF PART: 24cm³
 - (145) 21) ORDER SPECIFICATION: 2 269 915 583
 - (147) 23) CUTOFF AGAINST MATERIAL ACCUMULATION ACCORDING TO SUPPLIER REQUIREMENTS
 - (148) 24) MINIMUM ALLOWABLE DISTANCE AT PT1 FROM DATUM A TO BE NO LESS THAN 26.20mm DUE TO WRAP. MINIMUM ALLOWABLE DISTANCE AT PT2 FROM DATUM A TO BE LESS THAN 5.30 DUE TO WRAP.

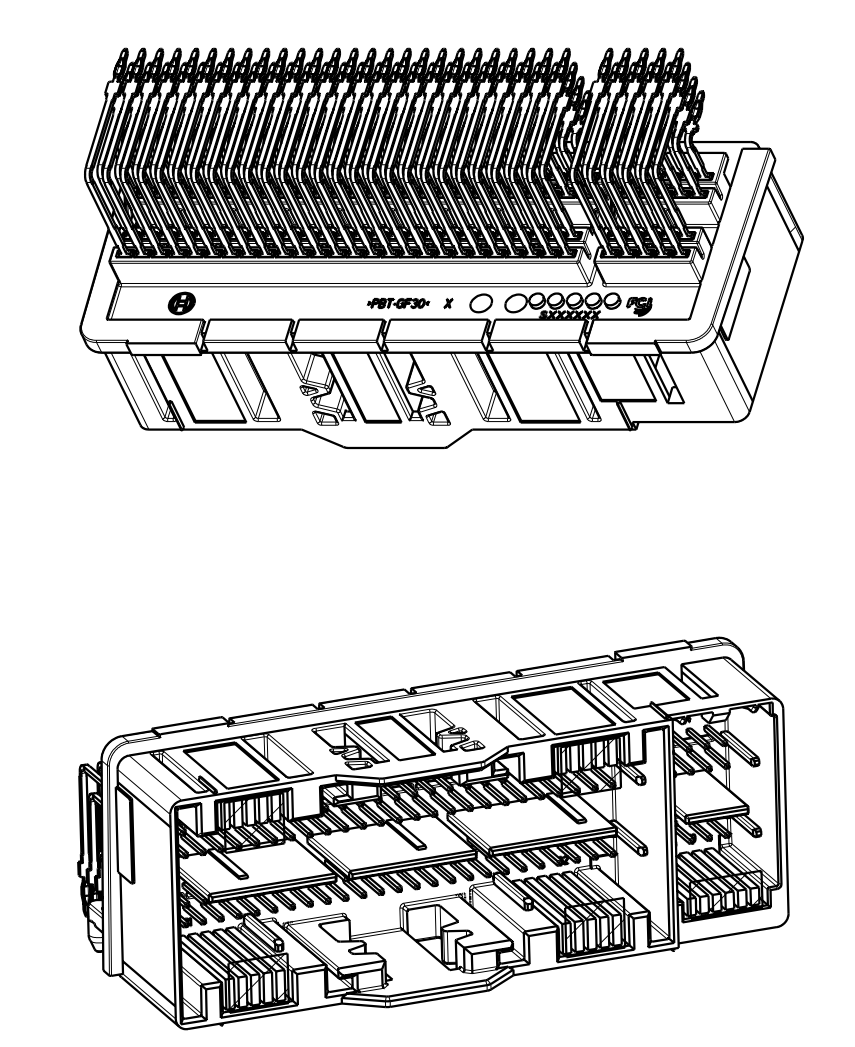

ENV. NO.	POS. NO.	CHANGE DESCRIPTION	DATE
799/10	A-C/20	ADDED TEXT "PIN ROW 2/3/4" TO THE DIM 3.35±0.1	
	A-C/16	ADDED DIM 2.15±0.1 WITH TEXT "PIN ROW 1"	
	A-C/1	ADDED NEW BASIC DIMENSION 45.455, 37.335, 8.12, 45.455, 53.575 WITH DIM NO 188, 189, 190, 191, AND 192 RESPECTIVELY	
	L-W/8	NEW SECTION VIEW G-G ADDED	
	R/9-13	NEW DETAIL VIEW X2, X3 ADDED	
	N/1-5	NOTE(13) "DELETE PRESSFIT REV C"	

LAST DIMENSION NUMBER



Компания «ЭлектроПласт» предлагает заключение долгосрочных отношений при поставках импортных электронных компонентов на взаимовыгодных условиях!

Наши преимущества:

- Оперативные поставки широкого спектра электронных компонентов отечественного и импортного производства напрямую от производителей и с крупнейших мировых складов;
- Поставка более 17-ти миллионов наименований электронных компонентов;
- Поставка сложных, дефицитных, либо снятых с производства позиций;
- Оперативные сроки поставки под заказ (от 5 рабочих дней);
- Экспресс доставка в любую точку России;
- Техническая поддержка проекта, помощь в подборе аналогов, поставка прототипов;
- Система менеджмента качества сертифицирована по Международному стандарту ISO 9001;
- Лицензия ФСБ на осуществление работ с использованием сведений, составляющих государственную тайну;
- Поставка специализированных компонентов (Xilinx, Altera, Analog Devices, Intersil, Interpoint, Microsemi, Aeroflex, Peregrine, Syfer, Eurofarad, Texas Instrument, Miteq, Cobham, E2V, MA-COM, Hittite, Mini-Circuits, General Dynamics и др.);

Помимо этого, одним из направлений компании «ЭлектроПласт» является направление «Источники питания». Мы предлагаем Вам помощь Конструкторского отдела:

- Подбор оптимального решения, техническое обоснование при выборе компонента;
- Подбор аналогов;
- Консультации по применению компонента;
- Поставка образцов и прототипов;
- Техническая поддержка проекта;
- Защита от снятия компонента с производства.



Как с нами связаться

Телефон: 8 (812) 309 58 32 (многоканальный)

Факс: 8 (812) 320-02-42

Электронная почта: org@eplast1.ru

Адрес: 198099, г. Санкт-Петербург, ул. Калинина, дом 2, корпус 4, литера А.