

1575.42MHZ/1592~1608MHz; 25 x 25 x 4mm

# GPS+GLONASS Patch Antenna



25.0 x 25.0 x 4.0mm

## APAE1590R2540AKDB1-T



This product is RoHS compliant  
Pb in ceramic (exempt per RoHS 2002/95/EC Annex (7)).

MSL level: Not Applicable

### FEATURES:

- High Gain
- Compact Size and Low Profile
- Pin type
- RoHS Compliance

### TYPICAL APPLICATIONS:

Automotive navigation, Marine buoys, Surveying equipment, Healthcare and medical monitoring devices, Cell phone, Laptop, PND, PDA

### STANDARD SPECIFICATIONS:

Parameters		Min.	Typ.	Max.	Units	Note
Center Frequency @ 10dB bandwidth	GPS	1575			MHz	(with adhesive tape on 70x70mm ground plane)
	GLONASS	1592~1608				
-10dB bandwidth		35	-----	-----	MHz	
Return Loss at Center Frequency		8	-----	-----	dB	
Axial Ratio	at 1575 MHz	10.3			dB	
	at 1592 MHz	5.8			dB	
	at 1609 MHz	11.6			dB	
Polarization Model		RHCP			----	
Impedance		50			$\Omega$	
Permittivity		21				
Frequency Temperature Coefficient		-----	-----	20	ppm/ $^{\circ}$ C	

### TEST CONDITIONS & TEST SETUP:

Parts shall be measured under a condition (Temp.: 20±15°C, Humidity: 65±20% R.H.)

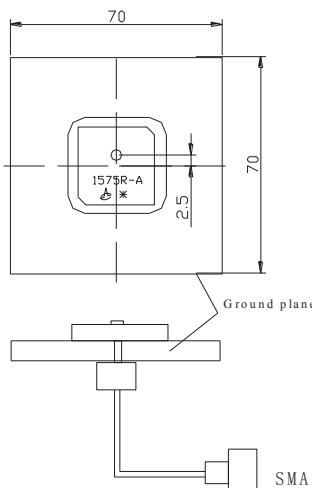

### PART IDENTIFICATION:

## APAE1590R2540AKDB1 -

#### Packaging

T100: 100pcs/box
T:1000pcs/box

1575.42MHz/1592~1608MHz; 25 x 25 x 4mm

GPS+GLONASS Patch Antenna

APAE1590R2540AKDB1-T



RoHS  
Compliant



25.0 x 25.0 x 4.0mm

This product is RoHS compliant

Pb in ceramic (exempt per RoHS 2002/95/EC Annex (7)).

### IMPEDANCE CHARACTERISTICS

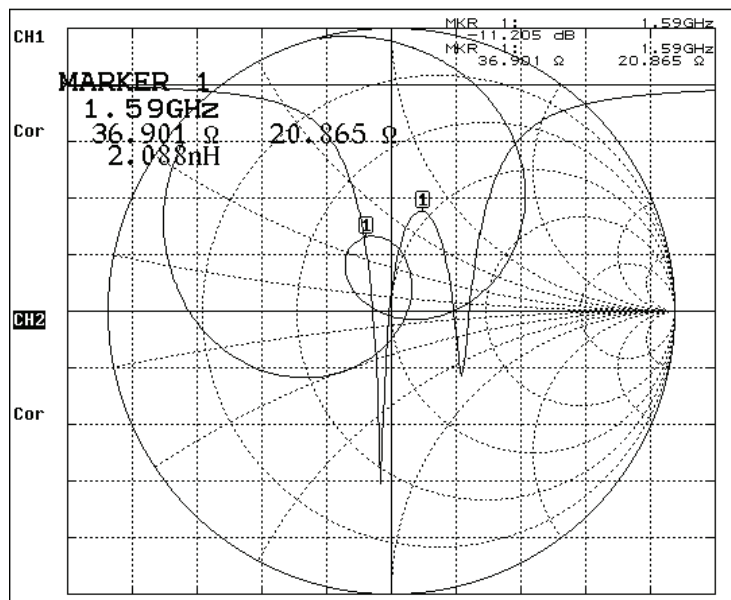

### OUTLINE DRAWING:

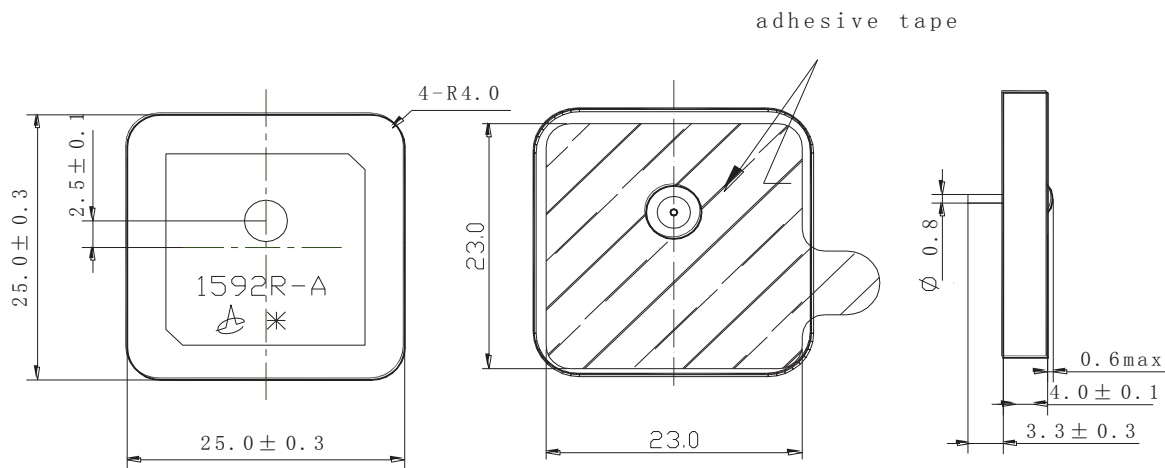

Dimension: mm

ABRACON IS  
ISO9001:2008  
CERTIFIED



ABRACON  
CORPORATION

Visit [www.abracon.com](http://www.abracon.com) for Terms & Conditions of Sale **Revised 07.14.12**  
30332 Esperanza, Rancho Santa Margarita, California 92688  
tel 949-546-8000 | fax 949-546-8001 | [www.abracon.com](http://www.abracon.com)

1575.42MHZ/1592~1608MHz; 25 x 25 x 4mm

# GPS+GLONASS Patch Antenna

**APAE1590R2540AKDB1-T**



This product is RoHS compliant

Pb in ceramic (exempt per RoHS 2002/95/EC Annex (7)).



25.0 x 25.0 x 4.0mm

## PACKAGING:

T100 = 2 trays containing a total of 100pcs devices

T = 40 trays containing a total of 2000pcs devices

NOTE: This product is vacuum packaged to reduce the possibility of oxidation and/or contamination during storage.

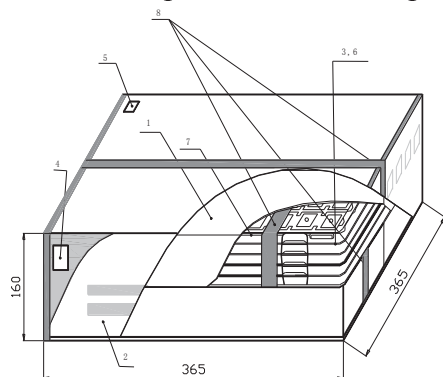

Inner Box dimensions (unit: mm)

NO.	Name
1	Inner Box
2	Package
3	Vacuum Bag
4	Certificate of approval
5	Label
6	Cushion
7	Tray
8	Adhesive tape

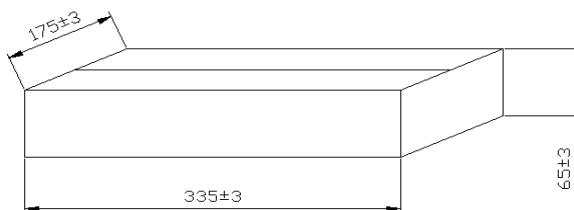

## CAUTION:

- (1) Do not apply excess mechanical stress to the component body or terminations. Do not attempt to re-form or bend the components as this will cause damage to the component.
- (2) Do not expose the component to open flame.
- (3) This specification applies to the functionality of the component as a single unit. Please insure the component is thoroughly evaluated in the application circuit.

## NOTE:

- (1) The parts are manufactured in accordance with this specification. If other conditions and specifications which are required for this specification, please contact ABRACON for more information.
- (2) ABRACON will supply the parts in accordance with this specification unless we receive a written request to modify prior to an order placement.
- (3) In no case shall ABRACON be liable for any product failure from in appropriate handling or operation of the item beyond the scope of this specification.
- (4) When changing your production process, please notify ABRACON immediately.
- (5) ABRACON Corporation's products are COTS – Commercial-Off-The-Shelf products; suitable for Commercial, Industrial and, where designated, Automotive Applications. ABRACON's products are not specifically designed for Military, Aviation, Aerospace, Life-dependant Medical applications or any application requiring high reliability where component failure could result in loss of life and/or property. For applications requiring high reliability and/or presenting an extreme operating environment, written consent and authorization from ABRACON Corporation is required. Please contact ABRACON Corporation for more information.
- (6) All specifications and Marking will be subject to change without notice.

**ATTENTION:** Abracon Corporation's products are COTS – Commercial-Off-The-Shelf products; suitable for Commercial, Industrial and, where designated, Automotive Applications. Abracon's products are not specifically designed for Military, Aviation, Aerospace, Life-dependant Medical applications or any application requiring high reliability where component failure could result in loss of life and/or property. For applications requiring high reliability and/or presenting an extreme operating environment, written consent and authorization from Abracon Corporation is required. Please contact Abracon Corporation for more information.

ABRACON IS  
ISO9001:2008  
CERTIFIED



Visit [www.abracon.com](http://www.abracon.com) for Terms & Conditions of Sale **Revised 07.14.12**  
30332 Esperanza, Rancho Santa Margarita, California 92688  
tel 949-546-8000 | fax 949-546-8001 | [www.abracon.com](http://www.abracon.com)



Компания «ЭлектроПласт» предлагает заключение долгосрочных отношений при поставках импортных электронных компонентов на взаимовыгодных условиях!

Наши преимущества:

- Оперативные поставки широкого спектра электронных компонентов отечественного и импортного производства напрямую от производителей и с крупнейших мировых складов;
- Поставка более 17-ти миллионов наименований электронных компонентов;
- Поставка сложных, дефицитных, либо снятых с производства позиций;
- Оперативные сроки поставки под заказ (от 5 рабочих дней);
- Экспресс доставка в любую точку России;
- Техническая поддержка проекта, помощь в подборе аналогов, поставка прототипов;
- Система менеджмента качества сертифицирована по Международному стандарту ISO 9001;
- Лицензия ФСБ на осуществление работ с использованием сведений, составляющих государственную тайну;
- Поставка специализированных компонентов (Xilinx, Altera, Analog Devices, Intersil, Interpoint, Microsemi, Aeroflex, Peregrine, Syfer, Eurofarad, Texas Instrument, Miteq, Cobham, E2V, MA-COM, Hittite, Mini-Circuits, General Dynamics и др.);

Помимо этого, одним из направлений компании «ЭлектроПласт» является направление «Источники питания». Мы предлагаем Вам помощь Конструкторского отдела:

- Подбор оптимального решения, техническое обоснование при выборе компонента;
- Подбор аналогов;
- Консультации по применению компонента;
- Поставка образцов и прототипов;
- Техническая поддержка проекта;
- Защита от снятия компонента с производства.



#### Как с нами связаться

**Телефон:** 8 (812) 309 58 32 (многоканальный)

**Факс:** 8 (812) 320-02-42

**Электронная почта:** [org@eplast1.ru](mailto:org@eplast1.ru)

**Адрес:** 198099, г. Санкт-Петербург, ул. Калинина, дом 2, корпус 4, литера А.