

Two Phase Dual-coil High Voltage Smart Fan Motor Driver**AH9280****General Description**

The AH9280 is a most advanced smart fan controller and Hall IC driver manufactured by special CMOS process. It is designed for 5V and 12V cooling fan. To allow survival in a harsh environment and lower the total system cost, the AH9280 has been designed with many powerful functions while almost eliminating all discrete components, such as, capacitor, resistor, transistor, diode and PC board.

The AH9280 can operate normally in an ambient temperature up to 125°C due to its Hall IC circuitry and power MOSFET output that allow low power dissipation.

When there is no motion for one second, the IC will automatically detect the locked rotor conditions, and enter protection mode, shutting off the motor driver for five seconds. Then, the IC will turn on the motor driver for one second to detect whether there is rotation condition, if fails, the IC will shut off motor driver for five seconds again. This sequence will be repeated until rotation condition is detected, and the IC enters normal operation. This feature can effectively prevent the AH9280 from overheating and damage due to long-time locked rotor condition.

Specially designed for driving large fans, the AH9280 is optimized for low start-up voltage.

The AH9280 is available in TO-94 package.

Features

- High-sensitivity Integrated Hall Sensor
- Low Start-up Voltage
- 5V and 12V Operation
- Peak Output Current up to 1200mA
- Power-efficient CMOS and Power MOSFETs
- Built-in Output Protection Clamping Diode
- Locked Rotor Shutdown and Auto-restart
- ESD Rating: 6000V (Human Body Model)
400V (Machine Model)

Applications

- 5V/12V DC Brushless Motor/Fan
- PC, Server, Laptop Cooling Fan
- Power Supply Cooling Fan
- Large/Small Sized Fan



Figure 1. Package Type of AH9280

Two Phase Dual-coil High Voltage Smart Fan Motor Driver**AH9280****Pin Configuration**

Figure 2. Pin Configuration of AH9280 (Front View)

Pin Description

Pin Number	Pin Name	Function
1	VCC	Power supply pin
2	DO	Output pin 1
3	DOB	Output pin 2
4	GND	Ground pin

Two Phase Dual-coil High Voltage Smart Fan Motor Driver AH9280

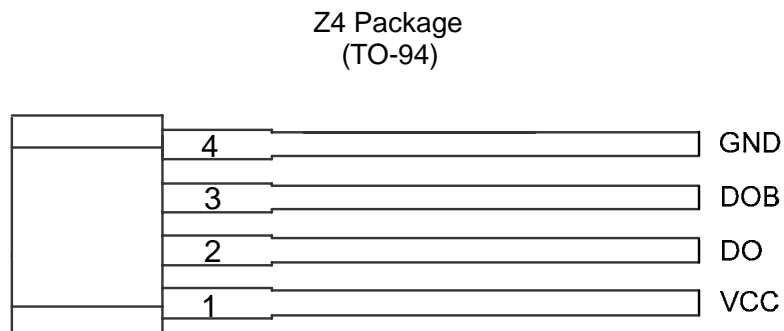
Functional Block Diagram

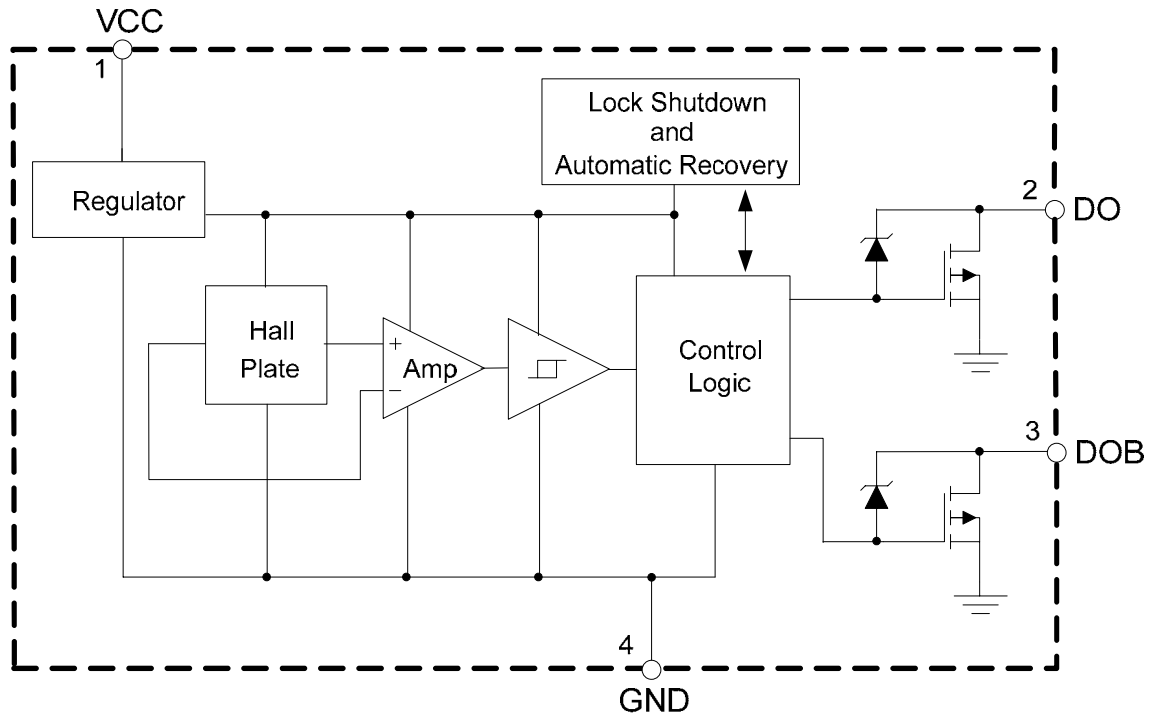
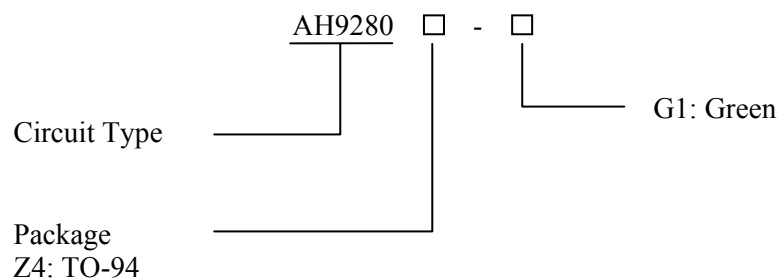

Figure 3. Functional Block Diagram of AH9280

Ordering Information



Package	Temperature Range	Part Number	Marking ID	Packing Type
TO-94	-40 to 125°C	AH9280Z4-G1	9280Z4-G1	Bulk

BCD Semiconductor's Pb-free products, as designated with "G1" suffix in the part number, are RoHS compliant and green.

**Two Phase Dual-coil High Voltage Smart Fan Motor Driver****AH9280****Absolute Maximum Ratings (Note 1, T_A=25°C)**

Parameter	Symbol	Value	Unit
Supply Voltage	V _{CC}	18	V
Peak Output Current	I _{OUT_P}	1200	mA
Continuous Output Current	I _{OUT_C}	600	mA
Supply Current (Fault)	I _{CC}	6	mA
Power Dissipation	P _D	600	mW
Thermal Resistance (Junction to Ambient)	θ _{JA}	208	°C/W
Storage Temperature	T _{STG}	-55 to 150	°C
ESD (Human Body Model)	ESD	6000	V
ESD (Machine Model)	ESD	400	V

Note 1: Stresses greater than those listed under “Absolute Maximum Ratings” may cause permanent damage to the device. These are stress ratings only, and functional operation of the device at these or any other conditions beyond those indicated under “Recommended Operating Conditions” is not implied. Exposure to “Absolute Maximum Ratings” for extended periods may affect device reliability.

Recommended Operating Conditions

Parameter	Symbol	Min	Max	Unit
Supply Voltage	V _{CC}	2.5	16	V
Ambient Temperature	T _A	-40	125	°C

Two Phase Dual-coil High Voltage Smart Fan Motor Driver AH9280

Electrical Characteristics

$V_{CC}=12V, T_A =25^{\circ}C$, unless otherwise specified.

Parameter	Symbol	Conditions	Min	Typ	Max	Unit
Supply Voltage	V_{CC}	Operating	2.5	12	16	V
Supply Current	I_{CC}	Average		4	6	mA
Output Current	I_{OUT}				500	mA
Output Leakage Current	$I_{LEAKAGE}$			0.1	10	μA
Saturation Voltage	V_{SAT}	$I_{OUT}=350mA$		600	1000	mV
Output On Time	T_{ON}			0.8		s
Output Off Time	T_{OFF}			5		s
Output Zener Break-down Voltage	V_Z			35		V

Magnetic Characteristics

$V_{CC}=12V, T_A =25^{\circ}C$, unless otherwise specified.

Parameter	Symbol	Min	Typ	Max	Unit
Operating Point	B_{OP}		20	50	Gauss
Releasing Point	B_{RP}	-50	-20		Gauss
Hysteresis	B_{HYS}		40		Gauss

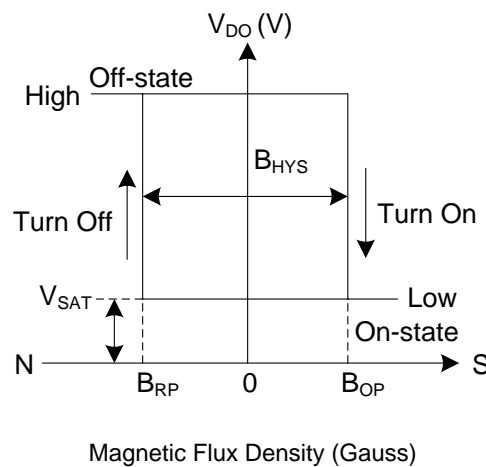

Test Circuit

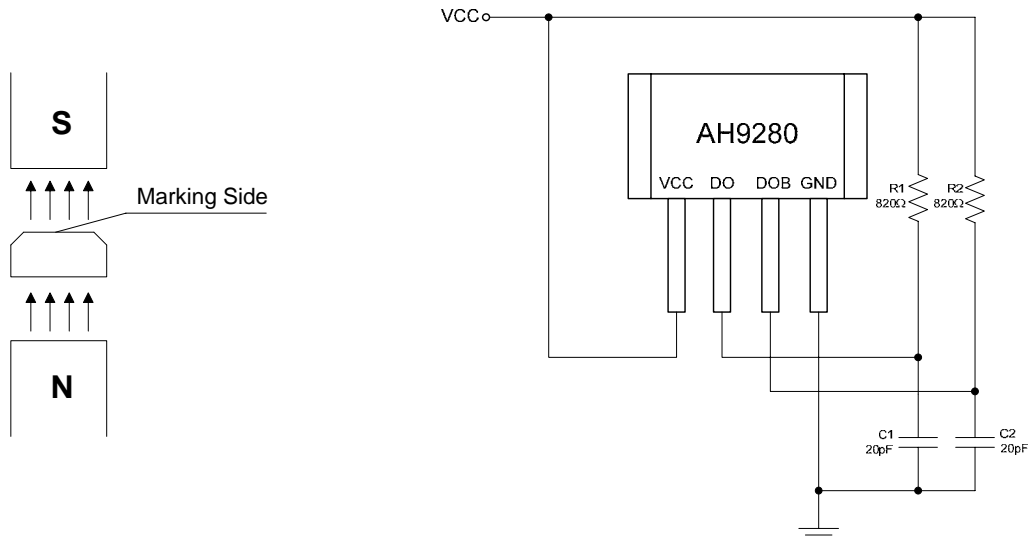

Figure 4. Basic Test Circuit of AH9280

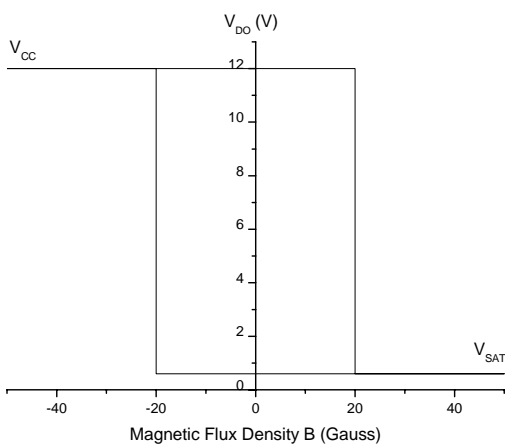

Figure 5. V_{DO} vs. Magnetic Flux Density

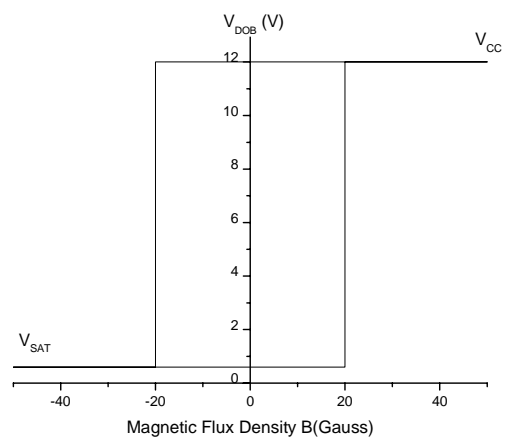

Figure 6. V_{DOB} vs. Magnetic Flux Density

Typical Performance Characteristics

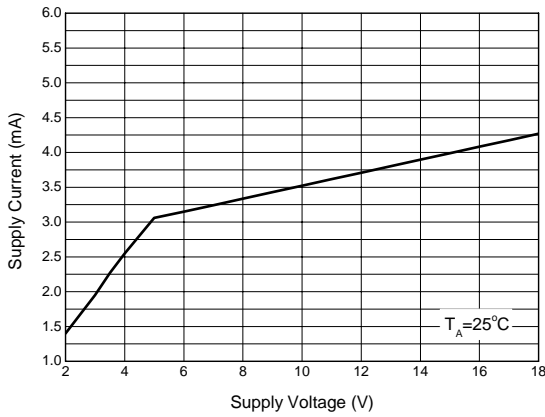

Figure 7. Supply Current vs. Supply Voltage

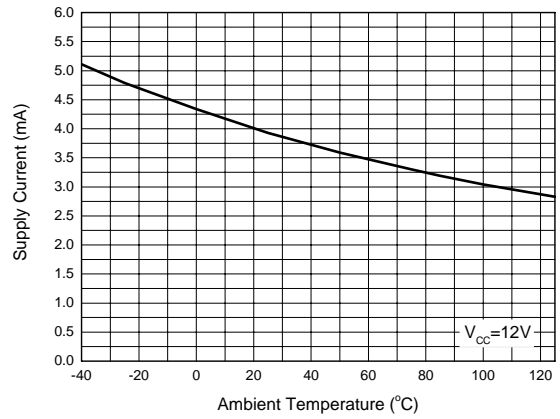

Figure 8. Supply Current vs. Ambient Temperature

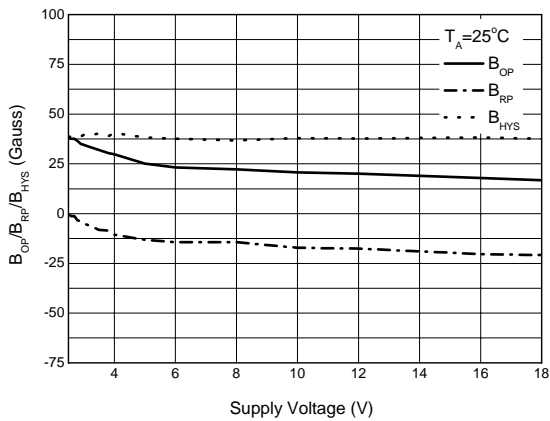

Figure 9. $B_{OP}/B_{RP}/B_{HYS}$ vs. Supply Voltage

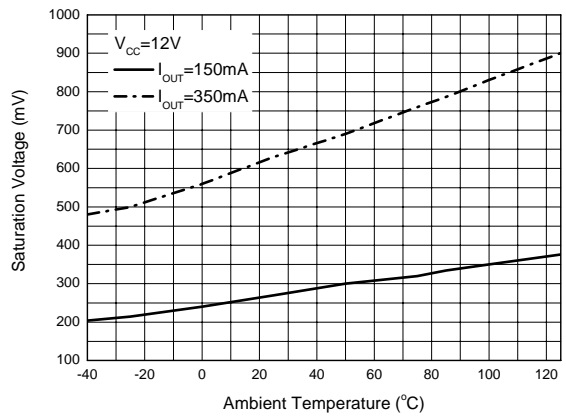

Figure 10. Saturation Voltage vs. Ambient Temperature

Typical Performance Characteristics (Continued)

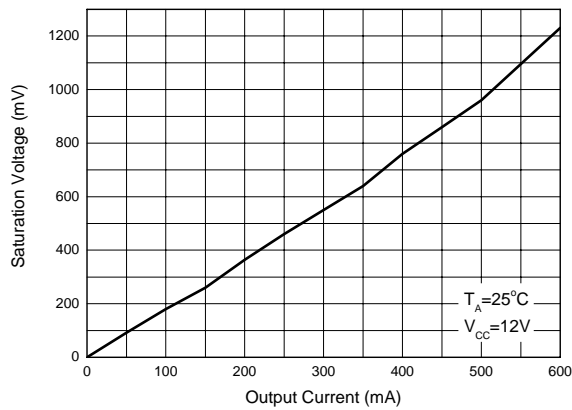

Figure 11. Saturation Voltage vs. Output Current

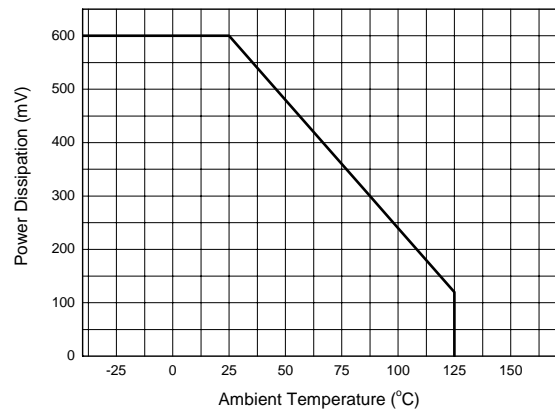

Figure 12. Power Dissipation vs. Ambient Temperature

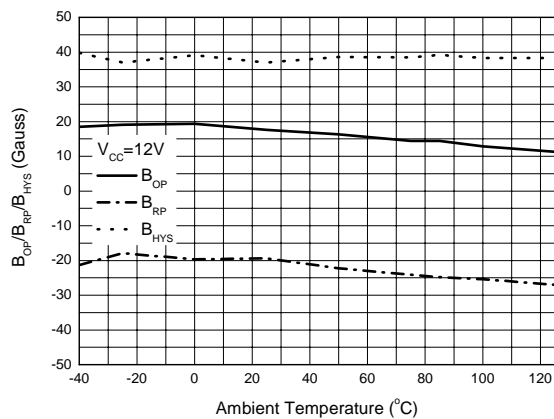

Figure 13. B_{OP}/B_{RP}/B_{HYS} vs. Ambient Temperature

Typical Application

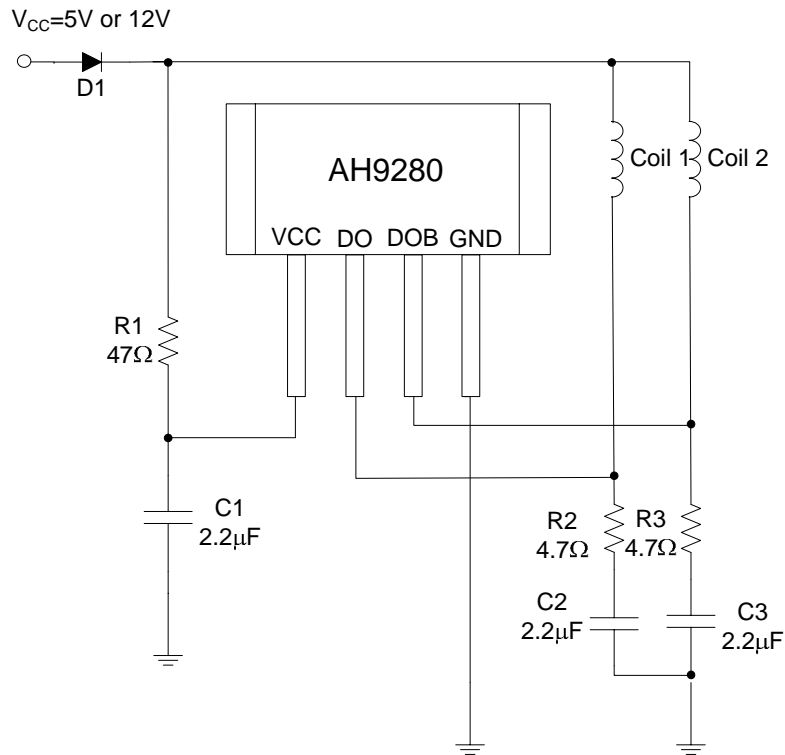

Figure 14 Typical Application 1 of AH9280 (Note 2)

Note 2:

1. D1 is an ordinary diode used to filter the noise from VCC and protect IC if VCC and GND are plugged reversed.
2. R1=47Ω typical.
3. C1=C2=C3=2.2μF typical, electrolytic capacitors are better. They should be fine tuned based on system design.
4. R2=R3=4.7Ω typical. They can be removed according to system requirement.

Typical Application (Continued)

Figure 15. Typical Application 2 of AH9280 (Note 3)

Note 3:

1. D1 is an ordinary diode used to filter the noise from VCC and protect IC if VCC and GND are plugged reversed.
2. R1=47Ω typical.
3. C1 =2.2μF typical, electrolytic capacitors are better. They should be fine tuned based on system design.
4. ZD1 and ZD2 breakdown voltage are 35V.

Two Phase Dual-coil High Voltage Smart Fan Motor Driver

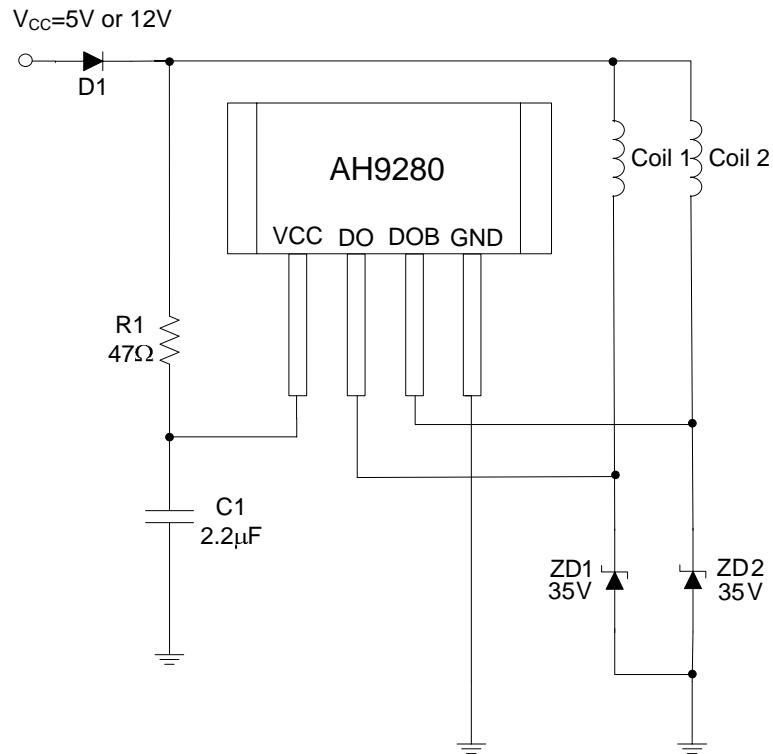
AH9280

Mechanical Dimensions

TO-94

Unit: mm(inch)

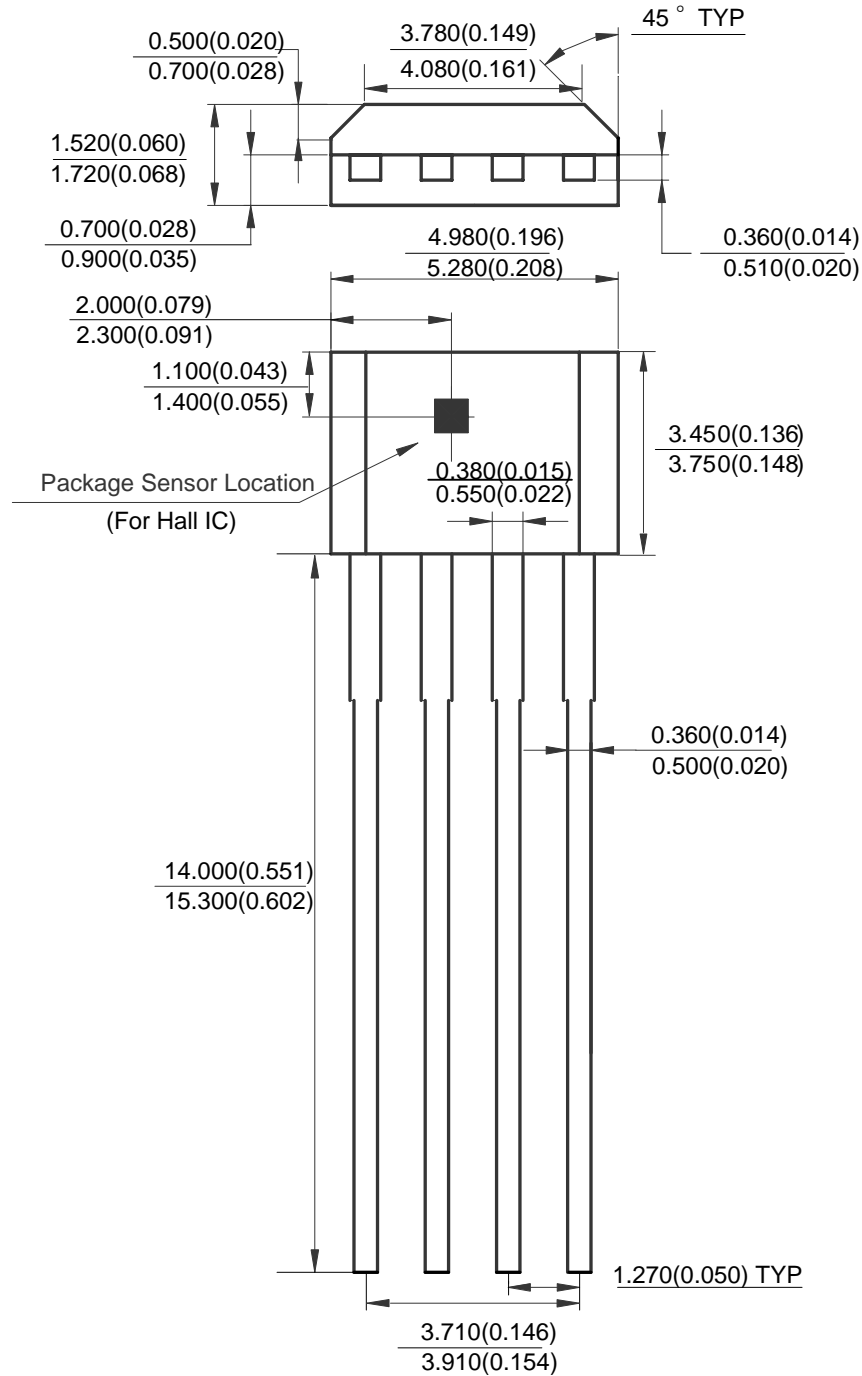



BCD Semiconductor Manufacturing Limited

<http://www.bcdsemi.com>

IMPORTANT NOTICE

BCD Semiconductor Manufacturing Limited reserves the right to make changes without further notice to any products or specifications herein. BCD Semiconductor Manufacturing Limited does not assume any responsibility for use of any its products for any particular purpose, nor does BCD Semiconductor Manufacturing Limited assume any liability arising out of the application or use of any its products or circuits. BCD Semiconductor Manufacturing Limited does not convey any license under its patent rights or other rights nor the rights of others.

MAIN SITE

- Headquarters

BCD Semiconductor Manufacturing Limited

No. 1600, Zi Xing Road, Shanghai Zizhu Science-based Industrial Park, 200241, China
Tel: +86-21-24162266, Fax: +86-21-24162277

- Wafer Fab

Shanghai SIM-BCD Semiconductor Manufacturing Co., Ltd.

800 Yi Shan Road, Shanghai 200233, China
Tel: +86-21-6485 1491, Fax: +86-21-5450 0008

REGIONAL SALES OFFICE

Shenzhen Office

Shanghai SIM-BCD Semiconductor Manufacturing Co., Ltd., Shenzhen Office

Unit A Room 1203, Skyworth Bldg., Gaoxin Ave. 1.S., Nanshan District, Shenzhen, China
Tel: +86-755-8826 7951
Fax: +86-755-8826 7865

Taiwan Office

BCD Semiconductor (Taiwan) Company Limited

4F, 298-1, Rui Guang Road, Nei-Hu District, Taipei, Taiwan
Tel: +886-2-2656 2808
Fax: +886-2-2656 2806

USA Office

BCD Semiconductor Corp.

30920 Huntwood Ave. Hayward, CA 94544, USA
Tel : +1-510-324-2988
Fax: +1-510-324-2788



Компания «ЭлектроПласт» предлагает заключение долгосрочных отношений при поставках импортных электронных компонентов на взаимовыгодных условиях!

Наши преимущества:

- Оперативные поставки широкого спектра электронных компонентов отечественного и импортного производства напрямую от производителей и с крупнейших мировых складов;
- Поставка более 17-ти миллионов наименований электронных компонентов;
- Поставка сложных, дефицитных, либо снятых с производства позиций;
- Оперативные сроки поставки под заказ (от 5 рабочих дней);
- Экспресс доставка в любую точку России;
- Техническая поддержка проекта, помощь в подборе аналогов, поставка прототипов;
- Система менеджмента качества сертифицирована по Международному стандарту ISO 9001;
- Лицензия ФСБ на осуществление работ с использованием сведений, составляющих государственную тайну;
- Поставка специализированных компонентов (Xilinx, Altera, Analog Devices, Intersil, Interpoint, Microsemi, Aeroflex, Peregrine, Syfer, Eurofarad, Texas Instrument, Miteq, Cobham, E2V, MA-COM, Hittite, Mini-Circuits, General Dynamics и др.);

Помимо этого, одним из направлений компании «ЭлектроПласт» является направление «Источники питания». Мы предлагаем Вам помощь Конструкторского отдела:

- Подбор оптимального решения, техническое обоснование при выборе компонента;
- Подбор аналогов;
- Консультации по применению компонента;
- Поставка образцов и прототипов;
- Техническая поддержка проекта;
- Защита от снятия компонента с производства.



Как с нами связаться

Телефон: 8 (812) 309 58 32 (многоканальный)

Факс: 8 (812) 320-02-42

Электронная почта: org@eplast1.ru

Адрес: 198099, г. Санкт-Петербург, ул. Калинина, дом 2, корпус 4, литера А.