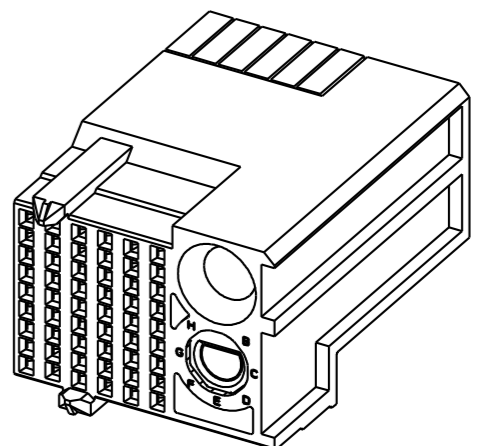
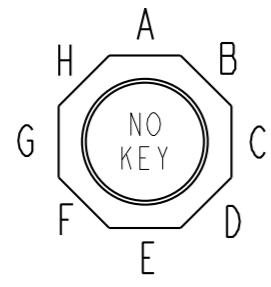
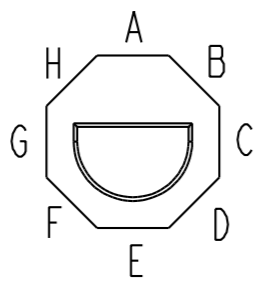
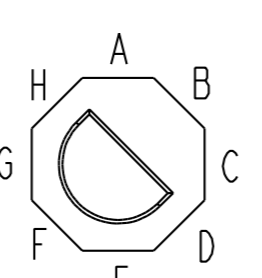
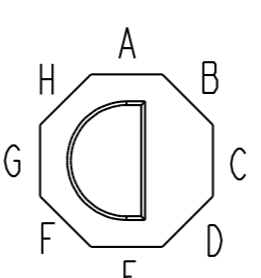
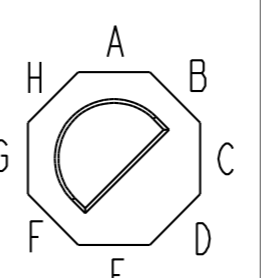
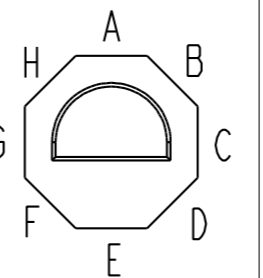
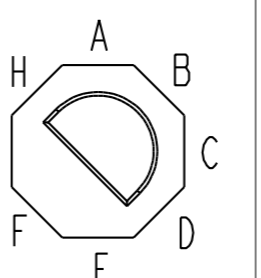
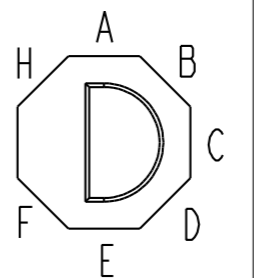
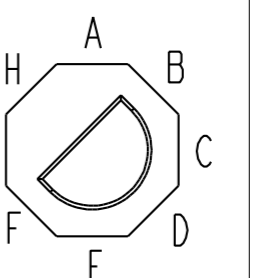
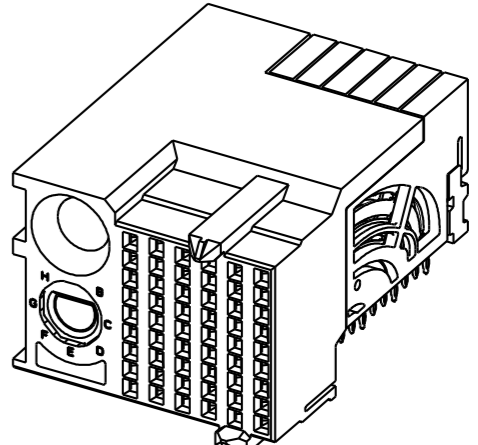
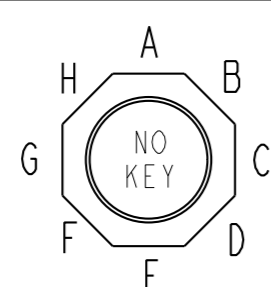
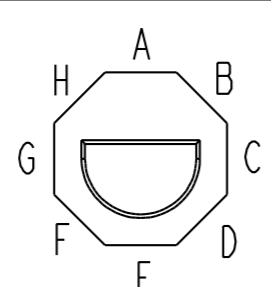
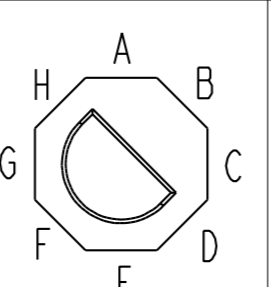
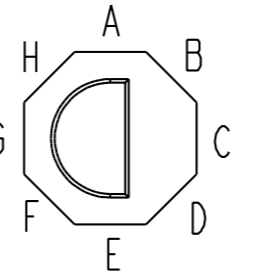
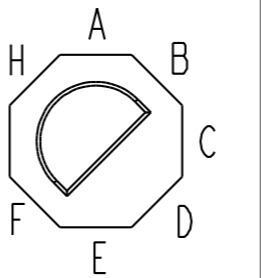
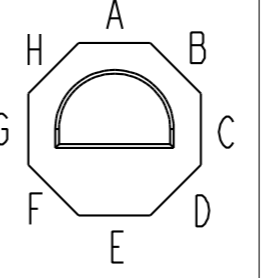
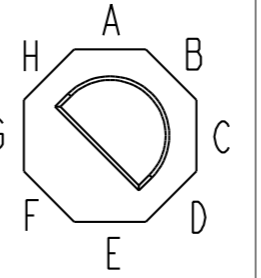
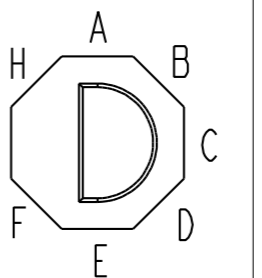
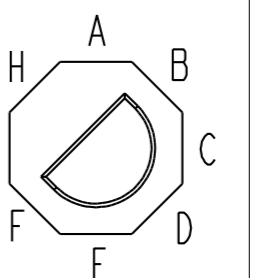

10135262 - 10X LF

LEAD-FREE DESIGNATION ONLY WITH APPLICABLE PLATING CODES

SEE NOTE 2

LETTER DESIGNATION REPRESENTED IN DASH NUMBER

MODULE DESCRIPTION	LETTER DESIGNATION REPRESENTED IN DASH NUMBER										BASE MODULE
RIGHT POLARIZING GUIDANCE MODULE (SEE SHEET 3)	N	J (NO KEY)	A	B	C	D	E	F	G	H	
	NO KEY NO GUIDE PIN										
LEFT POLARIZING GUIDANCE MODULE (SEE SHEET 2)	Z	Y (NO KEY)	P	Q	R	S	T	U	V	W	
	NO KEY NO GUIDE PIN										

Amphenol FCI

© 2016 AFCI

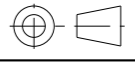
spec ref	---	dr	Jeny Ren	2015/05/20	projection	MM	size	A2	scale	8:1					
tolerance std	ASME Y14.5M	eng	Terry Luo	2019/01/31		←→	ecn no	-	rel level		Released				
TOLERANCES UNLESS OTHERWISE SPECIFIED		chr	Stone Li	2019/01/31			product family	AirMax VS2	rel level		Released				
surface	- ✓	linear	0.X	±.3	Amphenol FCI	TITLE	AIRMAX VSE R.A. RECEPTACLE	cat. no.	-	Product - Customer Drw	sheet 1 of 4				
			0.XX	±.15								drg no	10135262	rev	A
			0.XXX	±.050											
angular	0°	±°													

PDS: Rev :A

STATUS:Released

Printed: Jan 31, 2019

LEFT POLARIZATION WITH GUIDE

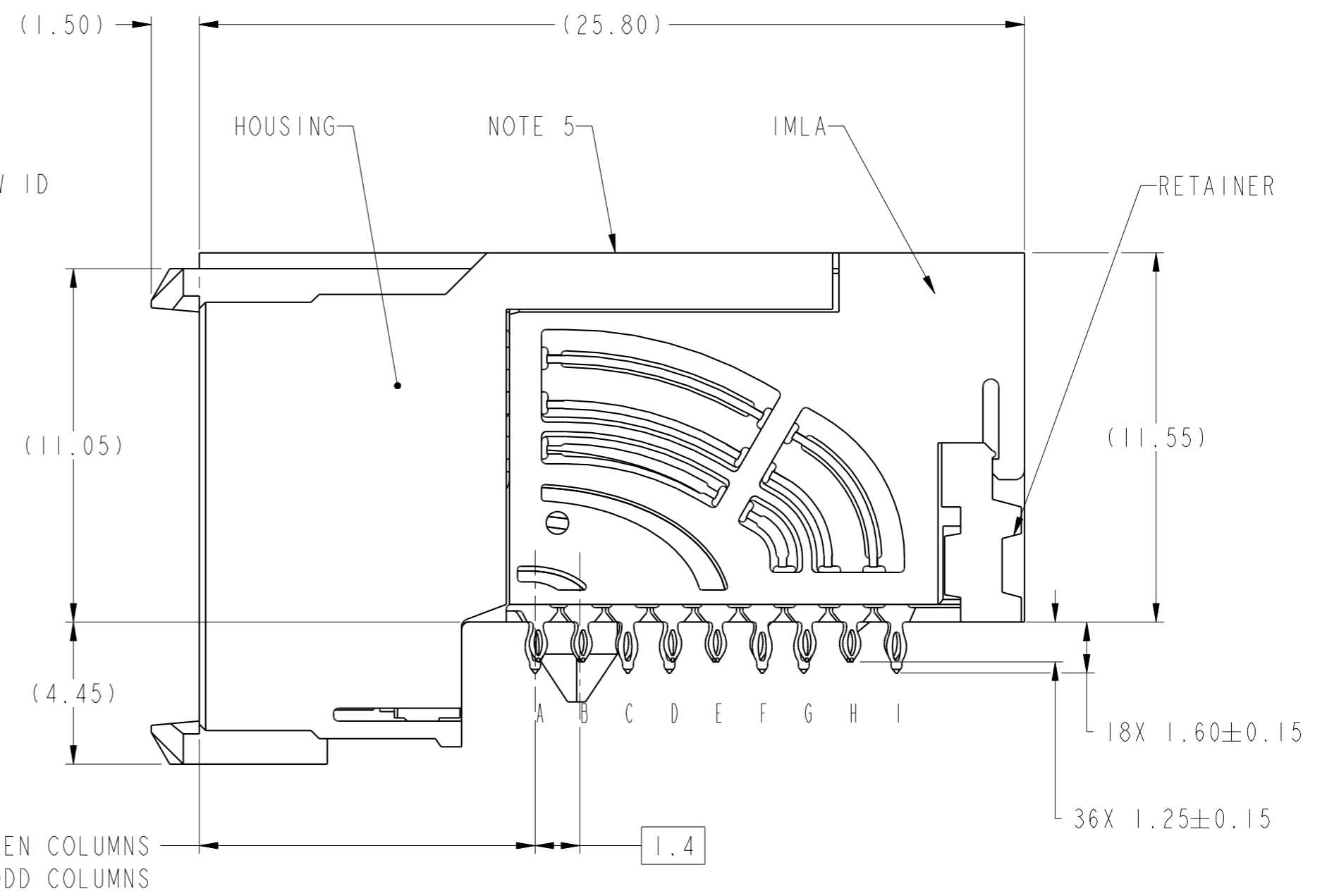
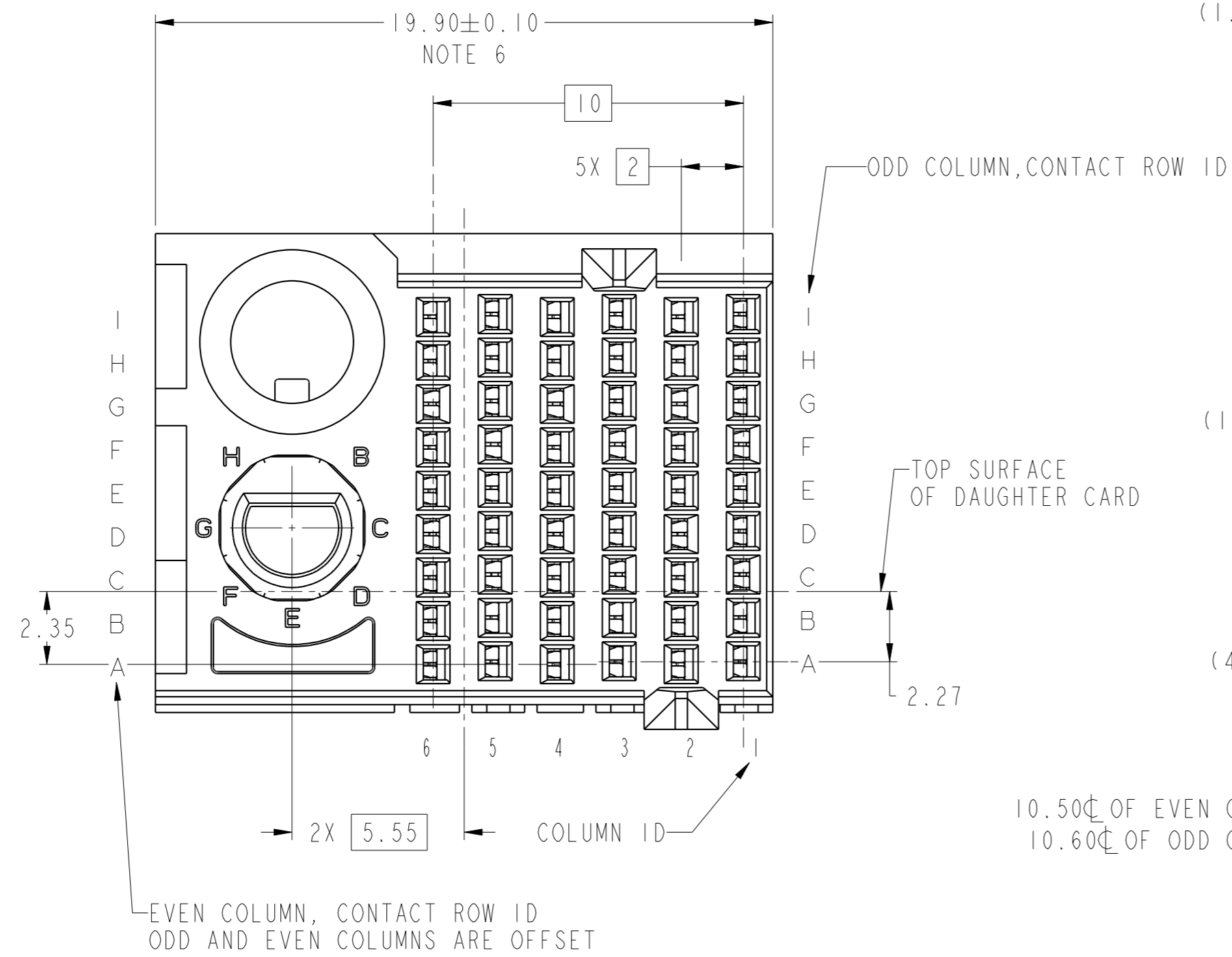

EVEN COLUMN, CONTACT ROW ID
ODD AND EVEN COLUMNS ARE OFFSET

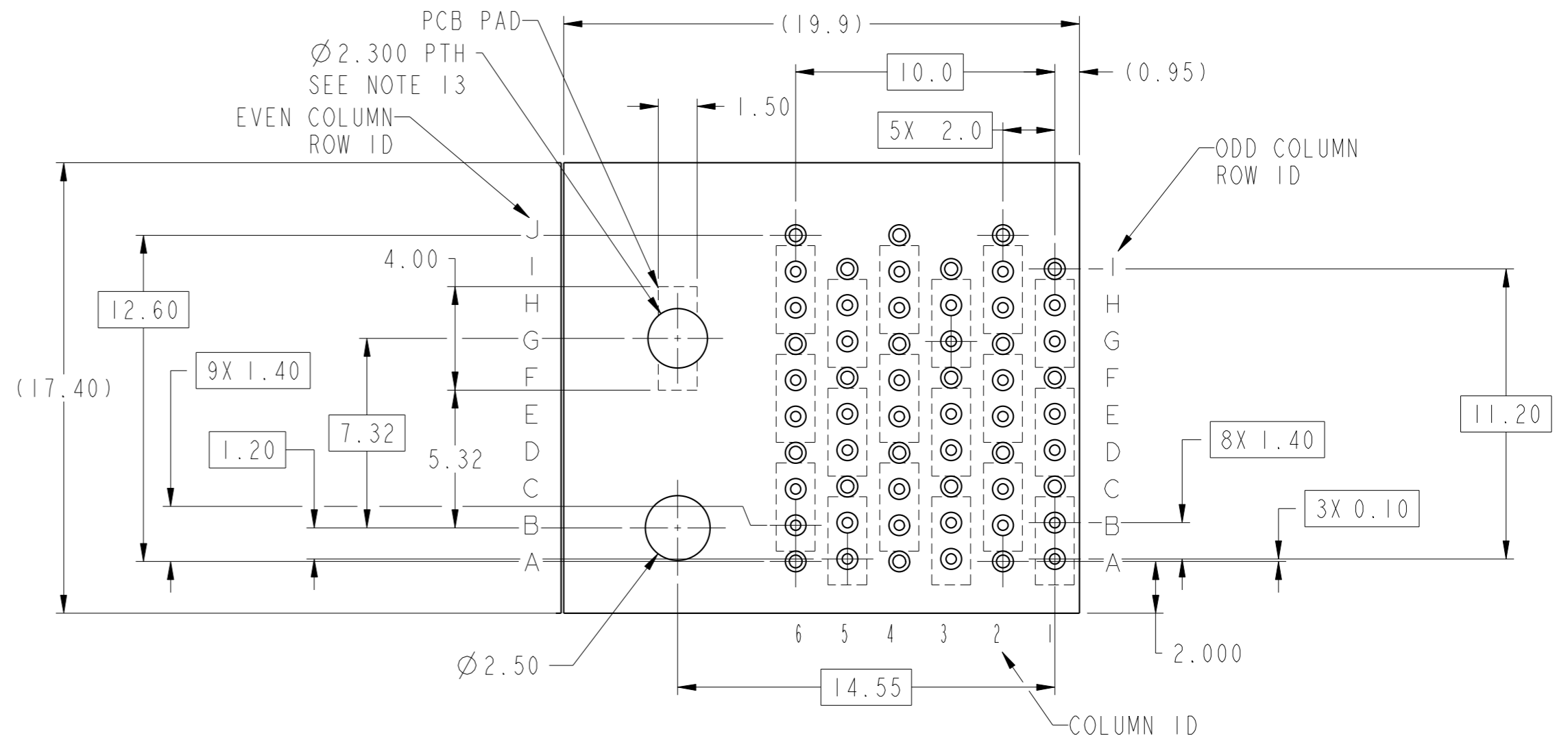
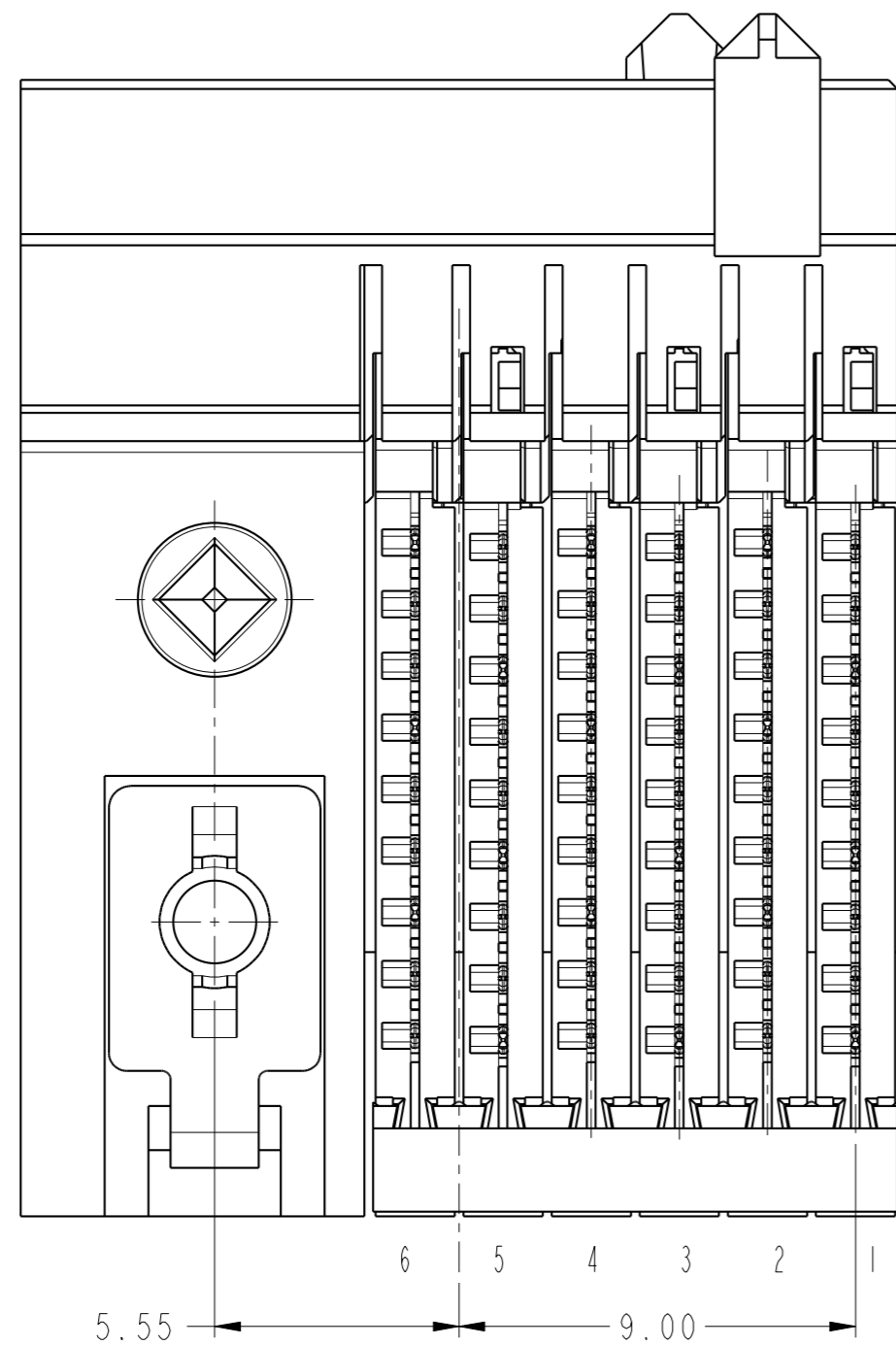

RECOMMENDED PCB LAYOUT

spec ref	---	dr	Jeny Ren	2015/05/20	projection	MM	size	A2	scale	6:1
tolerance std	ASME Y14.5M	eng	Terry Luo	2019/01/31			ecn no	-	rel level	Released
TOLERANCES UNLESS OTHERWISE SPECIFIED		chr	Stone Li	2019/01/31						
surface	linear	0.X	±.3		product family	AirMax VS2	title AIRMAX VSE R.A. RECEPTACLE ASS'Y, 3 PAIR, 54 POS, 6 IMLA, 20MM, W/GUIDE/KEY cat. no.	dwg no 10135262	rev A	
		0.XX	±.15		Product - Customer Drw					
		0.XXX	±.050			sheet 2 of 4				
	angular	0°	±°							

PDS: Rev :A

STATUS:Released

Printed: Jan 31, 2019

Amphenol FCI

© 2016 AFCI

RIGHT POLARIZATION WITH GUIDE

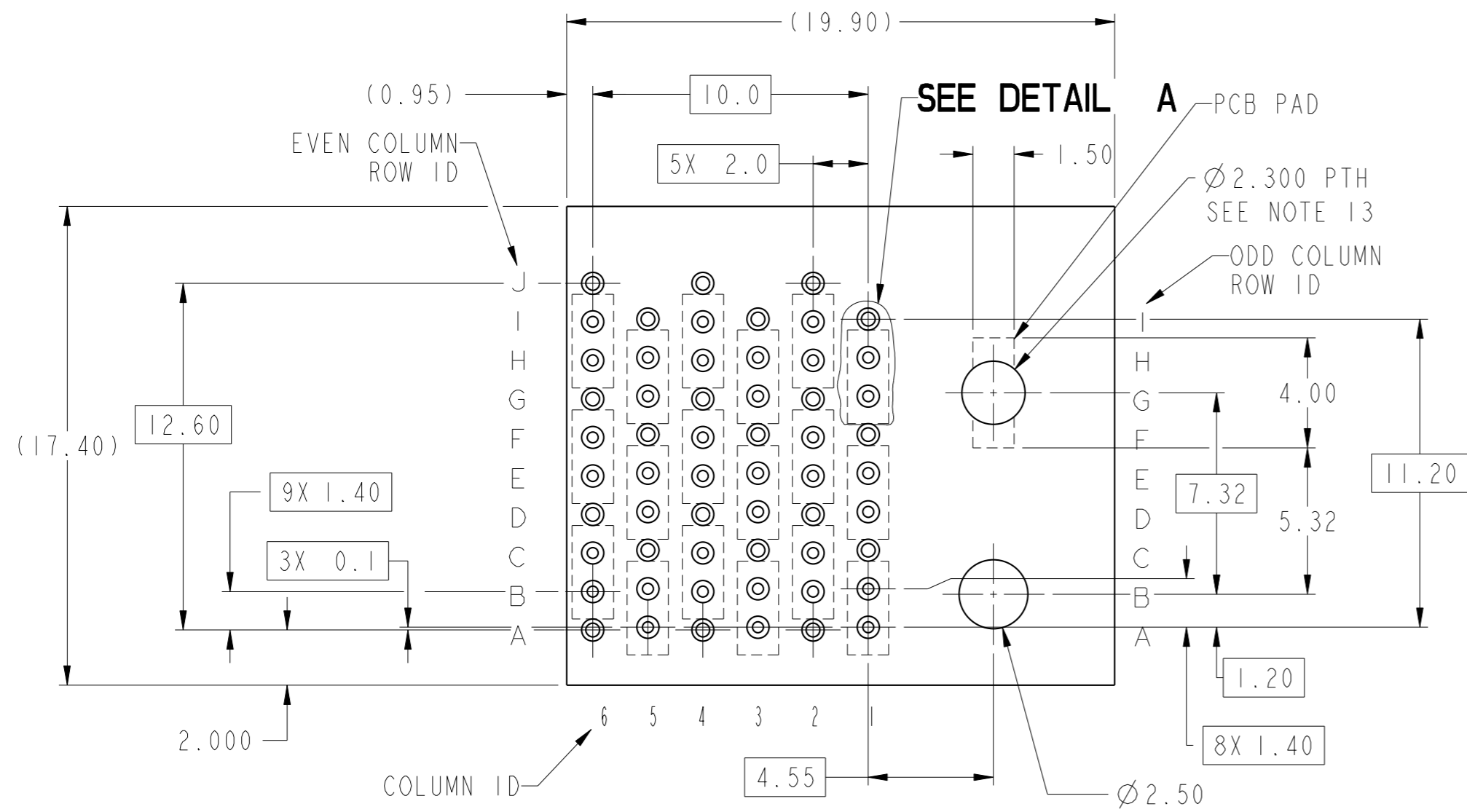
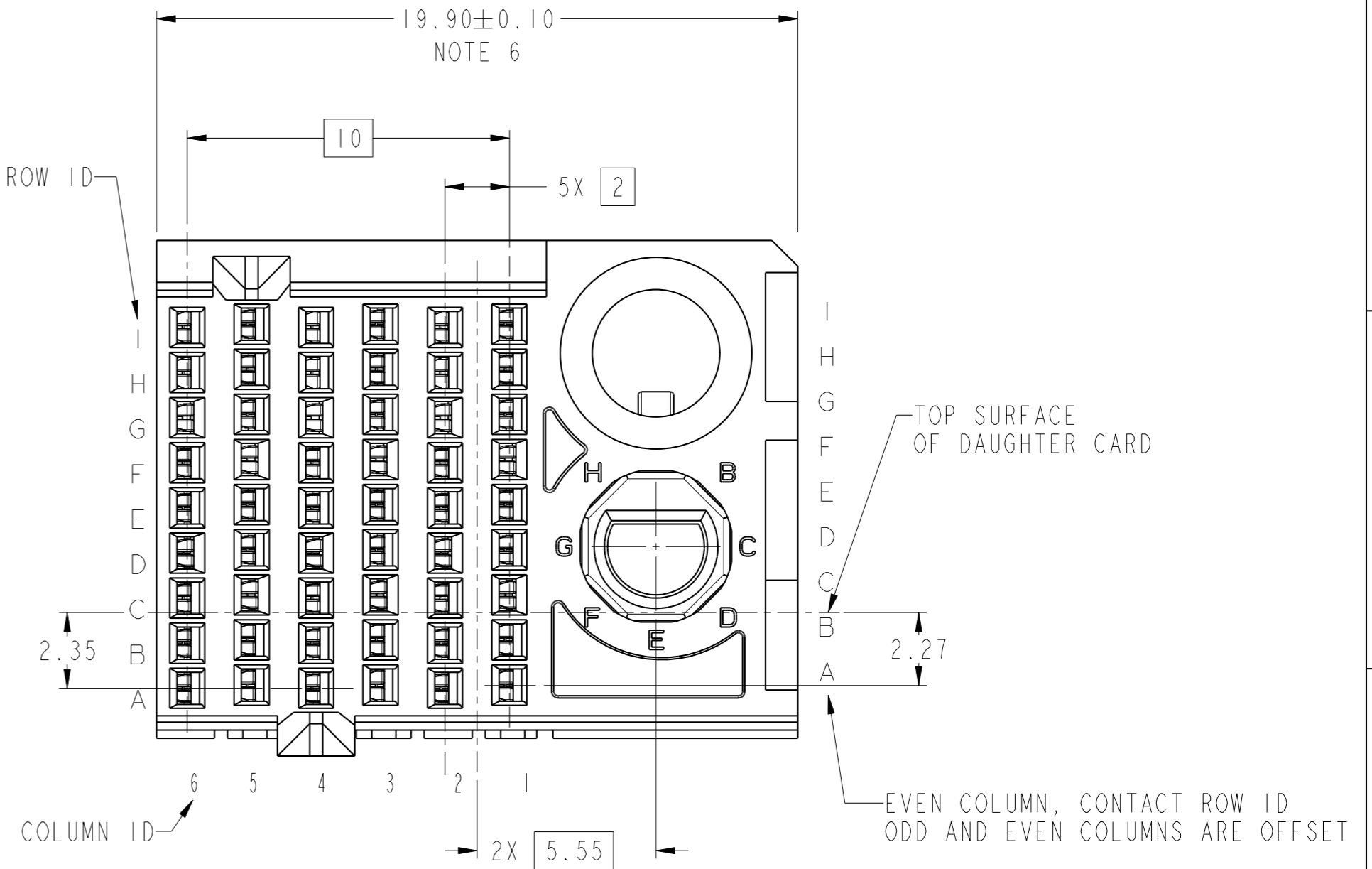
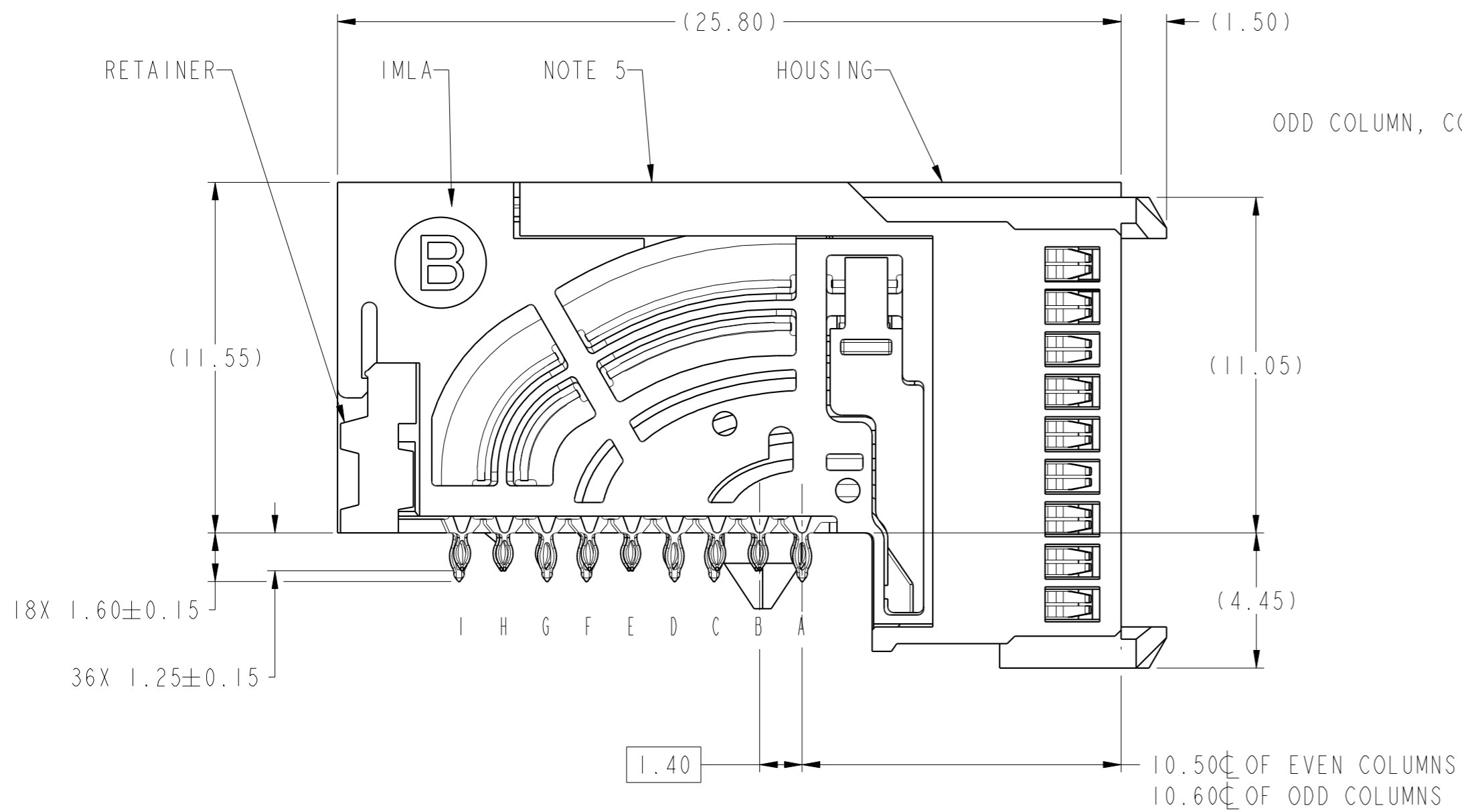

RECOMMENDED PCB LAYOUT

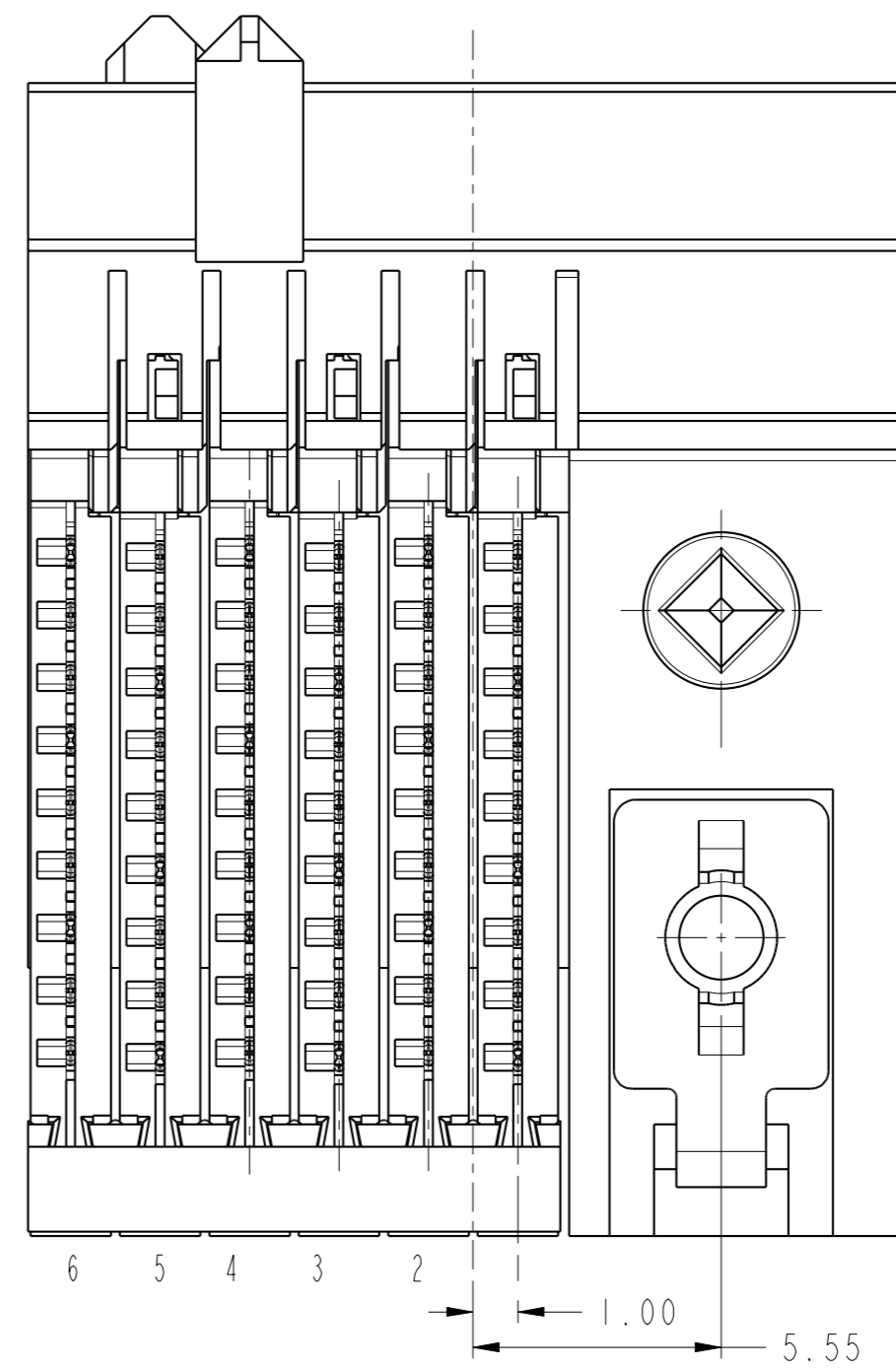

spec ref	---	dr	Jeny Ren	20150520	projection	MM	size	A2	scale	8:1		
tolerance std	ASME Y14.5M	eng	Terry Luo	2019/01/31			ecn no	-	product family AIRMAX VS2	rel level	Released	
TOLERANCES UNLESS OTHERWISE SPECIFIED		chr	Stone Li	2019/01/31			title	AIRMAX VSE R.A. RECEPTACLE		10135262	rev	A
surface	linear	0.X	±.3	0.XX			±.15	0.XXX		±.050	angular	0°
		Amphenol FCI		cat. no.		Product - Customer Draw		sheet 3 of 4				

PRODUCT NUMBER	PRESS-FIT TAIL PLATING TYPE
10135262-10*LF	TIN OVER NICKEL (LEAD FREE)

A

B

C

D

E

F

- 1 - CONNECTOR MATERIALS:
HOUSING: HIGH TEMP THERMOPLASTIC, NATURAL, UL94-V0
IMLA PLASTIC: HIGH TEMP THERMOPLASTIC, BLACK, UL94-V0
CONTACT: COPPER ALLOY
ORGANIZER: HIGH TEMP THERMOPLASTIC, WHITE, UL94-V0
- 2 - CONTACT PLATING:
SEPARABLE INTERFACE:
PERFORMANCE-BASED PLATING, QUALIFIED TO MEET THE REQUIREMENTS OF FCI PRODUCT SPECIFICATION GS-12-0956 INCLUDING TELCORDIA GR-1217-CORE (NOVEMBER 1995) CENTRAL OFFICE TEST SEQUENCE
- PRESS-FIT TAILS: SEE TABLE

- 3 - PRODUCT SPECIFICATION: GS-12-0956
- 4 - APPLICATION SPECIFICATION: GS-20-0305.

- 5 - PRODUCT MARKING, (PART NUMBER & LOT CODE), ON THIS SURFACE.

- 6 - THE MINIMUM CENTERLINE SPACING BETWEEN ADJACENT MODULES IS 20.0 MM.

- 7 - CONNECTOR OUTLINE MAY BE SCREEN PRINTED ONTO CUSTOMER PCB TO BE USED AS A GUIDE FOR MANUAL CONNECTOR PLACEMENT.

- 8 - REFER TO CUSTOMER DRAWING 10104444 FOR INFORMATION ON PCB HOLE DIAMETERS AND PLATING OPTIONS

- 9 - LEAD FREE PRODUCT MEETS THE EUROPEAN UNION DIRECTIVES & OTHER COUNTRY REGULATIONS AS DESCRIBED IN GS-22-008

- 10 - PACKAGING MEETS GS-14-920 LEAD FREE LABELING SPECIFICATION.

- 11 - GROUND CONTACTS (C, F, AND I IN ODD COLUMNS AND A, D, AND G, EVEN COLUMNS) REQUIRE ($\varnothing 0.500$) FINISHED HOLES. SIGNAL LOCATIONS REQUIRE ($\varnothing 0.400$) FINISHED HOLES.

- 12 - THESE OUTER VIAS (J) ARE OPTIONAL. WHILE NO CONNECTOR EONS ARE PRESSED INTO THESE HOLES WE RECOMMEND ($\varnothing 0.500$) FINISHED HOLES AT THESE LOCATIONS TO PROVIDE GROUND SYMMETRY THROUGH THE PCB.

- 13 - CUSTOMER CAN FIX THE CONNECTOR WITH THREAD FORMING SCREW THROUGH THIS PTH. THE SCREW IS #2-32, THE VALID LENGTH OF SCREW IS 4.5MM PLUS THE THICKNESS OF PCB.

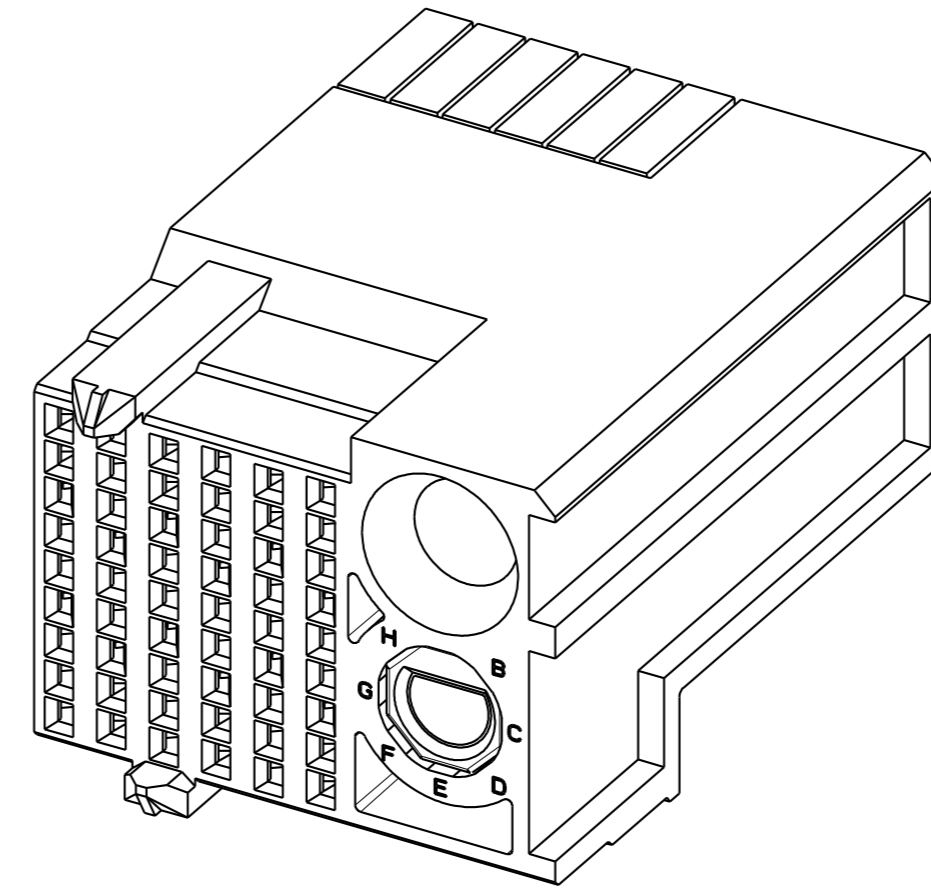

10135262-10ALF

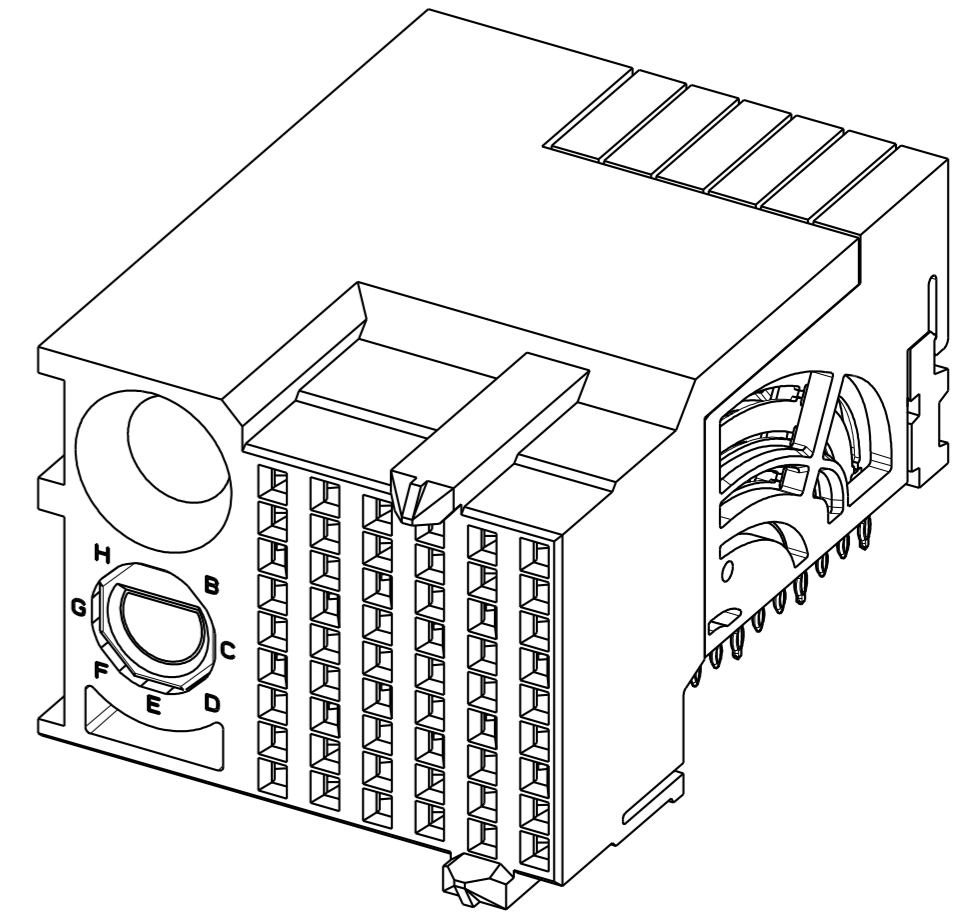

10135262-10PLF

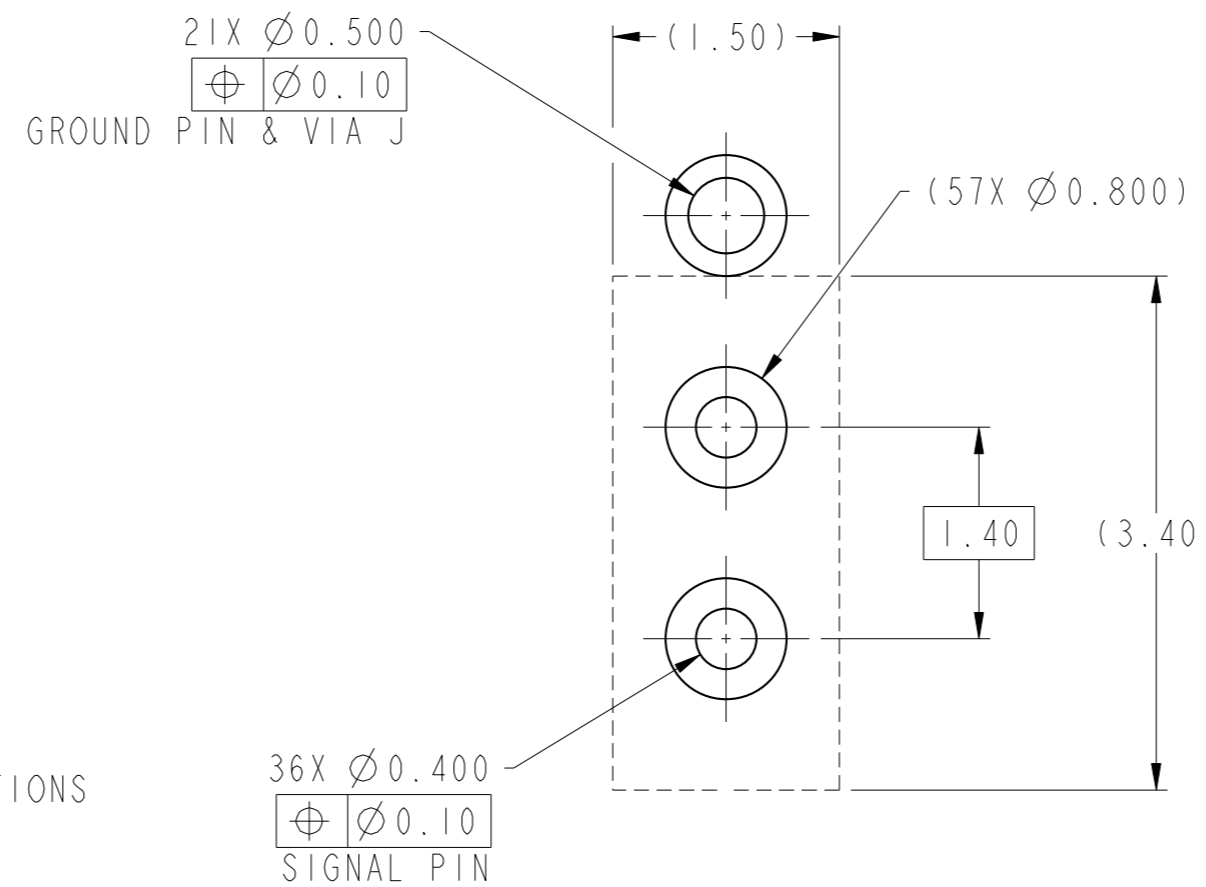
DETAIL A
SCALE 20:1

spec ref	---	dr	Jeny Ren	2015/05/20	projection	MM	size	A2	scale	6:1
tolerance std	ASME Y14.5M	eng	Terry Luo	2019/01/31			ecn no	-	rel level	Released
TOLERANCES UNLESS OTHERWISE SPECIFIED		chr	Stone Li	2019/01/31						
surface	linear	0.X	$\pm .3$		product family	AirMax VS2	dwg no	10135262	rev	A
		0.XX	$\pm .15$		title	AIRMAX VSE R.A. RECEPTACLE				
		0.XXX	$\pm .050$		ASS'Y, 3 PAIR, 54 POS, 6 IMLA, 20MM, W/GUIDE/KEY					
	angular	0°	$\pm ^\circ$	cat. no.	-	Product - Customer Drw	sheet 4 of 4			



Компания «ЭлектроПласт» предлагает заключение долгосрочных отношений при поставках импортных электронных компонентов на взаимовыгодных условиях!

Наши преимущества:

- Оперативные поставки широкого спектра электронных компонентов отечественного и импортного производства напрямую от производителей и с крупнейших мировых складов;
- Поставка более 17-ти миллионов наименований электронных компонентов;
- Поставка сложных, дефицитных, либо снятых с производства позиций;
- Оперативные сроки поставки под заказ (от 5 рабочих дней);
- Экспресс доставка в любую точку России;
- Техническая поддержка проекта, помощь в подборе аналогов, поставка прототипов;
- Система менеджмента качества сертифицирована по Международному стандарту ISO 9001;
- Лицензия ФСБ на осуществление работ с использованием сведений, составляющих государственную тайну;
- Поставка специализированных компонентов (Xilinx, Altera, Analog Devices, Intersil, Interpoint, Microsemi, Aeroflex, Peregrine, Syfer, Eurofarad, Texas Instrument, Miteq, Cobham, E2V, MA-COM, Hittite, Mini-Circuits, General Dynamics и др.);

Помимо этого, одним из направлений компании «ЭлектроПласт» является направление «Источники питания». Мы предлагаем Вам помощь Конструкторского отдела:

- Подбор оптимального решения, техническое обоснование при выборе компонента;
- Подбор аналогов;
- Консультации по применению компонента;
- Поставка образцов и прототипов;
- Техническая поддержка проекта;
- Защита от снятия компонента с производства.



Как с нами связаться

Телефон: 8 (812) 309 58 32 (многоканальный)

Факс: 8 (812) 320-02-42

Электронная почта: org@eplast1.ru

Адрес: 198099, г. Санкт-Петербург, ул. Калинина, дом 2, корпус 4, литера А.